

REV. A

DATE March 25, 1988  
(Revised May 31, 1988)

FMEA # 60-970-0790-01-SL1-01  
-SL2-01  
-SL3-01

END ITEM EFFECTIVITY:  
X X X  
OV102 OV103 OV104

MODEL NO: S70-0790-01

SUBSYSTEM: ECLSS

PART NUMBER:	PART NAME:	REFERENCE DESIGNATION:
KC-103-4	Seal Ring	SL1
1155001-904	O-Ring	SL2
1155001-906	O-Ring	SL3

CRITICALITY NUMBER: 2

FUNCTION: To form a pressure proof seal in the line under normal operating conditions.

CRITICAL FAILURE MODE: External leakage.

CAUSE: Material failure.

FAILURE EFFECT ON:

- (A) END ITEM: Loss of pressure and possible discharge of NH<sub>3</sub> would preclude continued operations.
- (B) INTERFACING SUBSYSTEM(S): Loss of NH<sub>3</sub> may cause degradation of GSE Servicing Operations.
- (C) ORBITER: Contamination of flight hardware by debris. Discharge of NH<sub>3</sub> onto TPS and adjacent flight hardware.
- (D) PERSONNEL: Exposure of personnel to NH<sub>3</sub>.

- HAZARDS:
- 1) Possible exposure of personnel to NH<sub>3</sub> discharge.
  - 2) Possible degradation of flight hardware.

DATE: March 25, 1988

REV : May 31, 1988

#### ACCEPTANCE RATIONALE

**DESIGN:** Review of assembly documents has provided design data points to be complied with for acceptance rationale. The KC103 teflon seal rings, per material specification MIL-R-8791, exhibit plastic deformation to conform to the surface of the connectors, and is corrosion resistant to anhydrous ammonia. The neoprene O-Rings are NH<sub>3</sub> resistant also and are used to seal contact surfaces with the application of 135 to 160 lbs of torque. The KC103 seals and O-Rings used are preassembled into the QD/filter set and verified for design conformance prior to use.

#### TEST:

**PROCUREMENT:** Random sampling of material lots for destructive testing information is performed by the vendor. Acceptance test data verified by receiving inspection.

**PRE-OPERATIONAL:** Per OMI V1027, V3519 : pressure test to system operating pressures with GN<sub>2</sub>: 550 psig, are conducted prior to ammonia servicing. Controlled amounts of NH<sub>3</sub> are used to wet the GSE lines prior to full servicing.

#### INSPECTION:

**PRE-INSTALLATION:** Manufacturing, assembly, and installation are verified by inspection. Seals are visually inspected, prior to installation, for damage and contaminants, Ring I.D. and O.D. are checked by inspection.

**AGE LIFE:** Per OMI S6013 (V6D41), the assembly is inspected annually for compliance to the material and assembly specifications.

**OPERATION:** Use of sniffers to detect NH<sub>3</sub> discharge minimize the risk of catastrophic failure. Manual valve controls are available to reduce the flow to the QDs, if necessary.

**DETECTION:** Visual and olfactory detection of ammonia discharge and the use of hand held sniffers to detect leakage.

**CORRECTION:** Isolation and replacement.

**FAILURE HISTORY:** Review of FRACA Data Base has provided no failure history on the KC-103-4 seal, or 1155001-904, 906 in this usage.

### END ITEM MODEL DESCRIPTION AND SCHEMATICS

The basic function of the S70-0790 ECLSS disconnect/filter assembly set, consisting of Models S70-0790-01 through S70-0790-12, is to provide quick-disconnects and filters for the various flex hoses used during ground servicing operations on the Orbiter. The set consists of couplings, filters, supports, fixtures, and hose and tube attachments required for supplying the orbiter with ammonia, Freon and water coolant, oxygen, pneumatic pressure, and potable water; for draining the waste disposal system; and for servicing the Orbiter atmospheric revitalization pressure control system (ARPCS).

Detailed descriptions of the individual subassemblies to follow.

AMMONIA SERVICING SET - S70-0790-01

The set is provided to facilitate servicing of the Orbiter NH<sub>3</sub> tanks through the Ammonia Servicing Panel, Right Side Aft Fuselage (see Figure 3.1). The set consists of 25 micron in-line filters, self latching normally closed quick-disconnects (QD), an Ammonia Support Disconnect Jumper for attachment of lines together for routing of NH<sub>3</sub>, and a vacuum flushing filter for leak check and evacuation of NH<sub>3</sub> from the boiler system. In line seals provide for the containment of NH<sub>3</sub> at the component unions and the NH<sub>3</sub> servicing/heat flushing set operates within an open scupper for containment of possible leakage. Individual components of the set are identified in table 3.1.

TABLE 3.1

ITEM	FUNCTION	LOCATION
1	NH <sub>3</sub> system A fill	Right side aft fuselage
2	NH <sub>3</sub> system B fill	"
3	NH <sub>3</sub> sys A overflow	"
4	NH <sub>3</sub> sys B overflow	"
5	NH <sub>3</sub> sys A test coupling	"
6	NH <sub>3</sub> sys B test coupling	"
7	NH <sub>3</sub> disconnect jumper	"
8	NH <sub>3</sub> vacuum fixture	"

31 4 0 0 0 - 7  
3 4 4 0 0 0 0 0 0 0 0  
3 4 4 0 0 0 0 0 0 0 0  
3 4 4 0 0 0 0 0 0 0 0

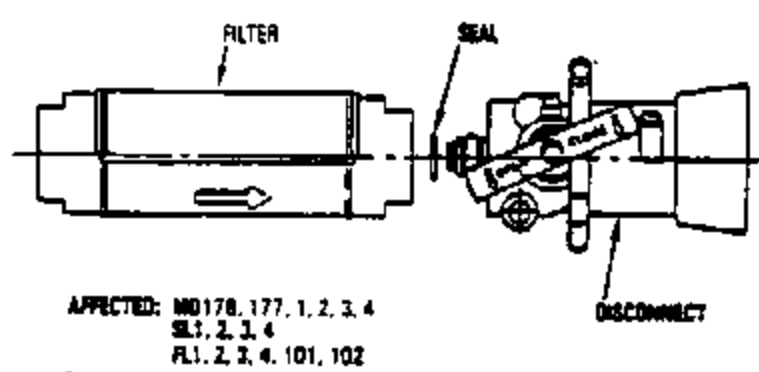
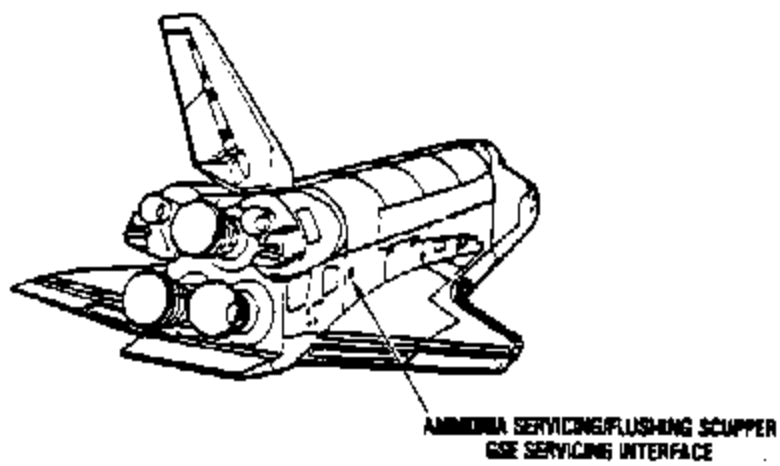

Figure 3.1. Ammonia Servicing Set (570-0790-01)

REV. A

DATE March 25, 1988  
(Revised May 31, 1988)

END ITEM: S70-0790-01, AMMONIA SERVICING SET

PART NUMBER/ REF. DESIGNATOR	PART NAME	QTY. (PER SYSTEM)	HDW. CRIT.
KC103-4 SL1	Seal Ring	2	2
1155001-904 SL2	O-Ring	2	2
1155001-906 SL3	O-Ring	10	2
ME286-0068 FL101,102	In-line Miniature Filter/Low Pressure	2	2
ME286-0066 FL1,2,3,4	In-line Miniature Filter/High Pressure	4	2
MC276-0030 MD1,2,3,4 MD176,177	QD assembly with cut off valve	8	2

The OMRSD, File VI, is in development and at the completion of this FMEA/CIL each critical item will be reviewed against it. If necessary, the OMRSD will be revised to cover all applicable requirements for each critical item.

TABLE 8-1  
 CRITICAL ITEMS LIST