

N 84 - 2 0 6 3 7



 **Lockheed**

Missiles & Space Company

Huntsville Research & Engineering Center

4800 Bradford Drive, Huntsville, AL 35807

 **Lockheed**
Missiles & Space Company, Inc
Huntsville Research & Engineering Center

Cummings Research Park
4800 Bradford Drive
Huntsville, AL 35807

SPACE SHUTTLE MAIN ENGINE
POWERHEAD STRUCTURAL MODELING,
STRESS AND FATIGUE LIFE ANALYSIS

VOLUME III - STRESS SUMMARY OF BLADES
AND NOZZLES AT FPL AND 115 PERCENT
RPL LOADS - SSME HPFTP AND HPOTP
BLADES AND NOZZLES

December 1983

Contract NAS8-34978

Prepared for National Aeronautics and Space Administration
Marshall Space Flight Center, AL 35812

by

J.C. Hammett
C.H. Hayes
J.M. Price
J.K. Robinson
G.A. Teal
J.M. Thomson
D.M. Tilley
C.T. Welch

APPROVED



C.T. Welch, Manager (Acting)
Product Engineering & Development Section

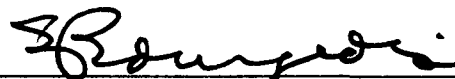

S. V. Bourgeois
Director

Page intentionally left blank

Page intentionally left blank

FOREWORD

This report summarizes the results of work performed on Contract NAS8-34978. The work was performed by personnel of the Product Engineering & Development Section of Lockheed's Huntsville Research & Engineering Center, for the National Aeronautics and Space Administration, George C. Marshall Space Flight Center, Alabama. The Contracting Officer's technical representative for this study is Mr. Norman C. Schlemmer, Structures and Propulsion Laboratory, Engineering Analysis Division, Stress Analysis Branch (EP46).

This report is divided into four volumes with a section covering one aspect of analysis for all components and loads, and a fourth section for investigation of unscheduled events and special tasks undertaken during the effort. The volumes are:

- Volume I - Gasdynamic Environment of the SSME HPFTP and HPOTP Turbines, LMSC-HREC TR D867333-I.
- Volume II - Dynamics of Blades and Nozzles - SSME HPFTP and HPOTP, LMSC-HREC TR D867333-II.
- Volume III - Stress Summary of Blades and Nozzles at FPL and 115 percent RPL Loads SSME HPFTP and HPOTP Blades and Nozzles, LMSC-HREC TR D867333-III.
- Volume IV - Summary of Investigation of Unscheduled Events and Special Tasks, LMSC-HREC TR D867333-IV.

It should be noted that this report summarized our findings. A great body of data exists in the form of computer printout and magnetic tapes and is available to any interested reader for either amplification of the summarized data or as a basis for further work.

Page intentionally left blank

Page intentionally left blank

CONTENTS

<u>Section</u>	<u>Page</u>
FOREWORD	iii
1 INTRODUCTION	1-1
<hr style="border-top: 1px solid black; width: 100%;"/> PART I <hr style="border-top: 1px solid black; width: 100%;"/>	
2 SSME TURBOPUMP BLADES	2.1-1
2.1 SSME Blades - Model Description	2.1-1
2.2 HPFTP First Stage Turbine Blade Temperatures and Stresses at FPL and 115% RPL	2.2-1
2.3 HPFTP Second Stage Turbine Blade Temperatures and Stresses at FPL and 115% RPL	2.3-1
2.4 HPOTP First Stage Turbine Blade Temperatures and Stresses at FPL and 115% RPL	2.4-1
2.5 HPOTP Second Stage Turbine Blade Temperatures and Stresses at FPL and 115% RPL	2.5-1
<hr style="border-top: 1px solid black; width: 100%;"/> PART II <hr style="border-top: 1px solid black; width: 100%;"/>	
3 SSME TURBOPUMP NOZZLES	3.1-1
3.1 SSME Nozzles - Mode Description	3.1-1
3.2 HPFTP First Stage Nozzle Stresses at FPL and 115% RPL	3.2-1
3.3 HPFTP Second Stage Nozzle Stresses at FPL and 115% RPL	3.3-1
3.4 HPOTP First Stage Nozzle Stresses at FPL and 115% RPL	3.4-1
3.5 HPOTP Second Stage Nozzle Stresses at FPL and 115% RPL	3.5-1

1. INTRODUCTION

The objective of this phase of the analysis is to apply the gasdynamic environments described in Volume I of this report to the turbine blades and nozzles of the HPFTP and HPOTP. Additionally, centrifugal loads were applied to the blades to account for the pump rotation at FPL and 115 percent RPL.

Section 2 describes the computer models used in the blade analysis with results presented in the form of temperature and stress contour plots. Section 3 gives similar information for the nozzles.

PART I

2. SSME TURBOPUMP BLADES

Section 2.1 describes the computer models used for the analysis and provides a guide for the reader in following the subsequent results in Sections 2.2 through 2.5.

2.1 SSME BLADES - MODEL DESCRIPTION

Four NASTRAN models were constructed to simulate the first and second stage turbine blades of the HPFTP and the HPOTP. The general approach to modeling of all four blades is the same making use of eight-node solid elements to represent the turbine blade geometry. Figures 2-1 through 2-4 show computer generated plots and specifications of each turbine blade model. The series of figures following these plots gives more specific information pertaining to grid and element locations. The models are defined in a rectangular coordinate system with Z radially outward and X in the direction opposite of gas flow. The turbine blades were modeled in their entirety with the exception of the "Fir Tree" on each blade which was not modeled to avoid additional size and complexity. The models were constrained at the base of the shank in all directions in order to simulate the turbine blades installed in the rotor disk.

Loads simulating the turbine blade thermal environment at steady state FPL and 115 percent power levels were applied to the models resulting in steady state blade temperatures. These temperatures were applied as static loads along with pressure and centrifugal loads. Stresses and displacements were output for each individual load case (thermal, pressure, and centrifugal) as well as the combination of all three load cases.

Results of the thermal and stress analyses are presented in Section 2.2 through 2.5 in the form of surface temperature and stress contour plots.

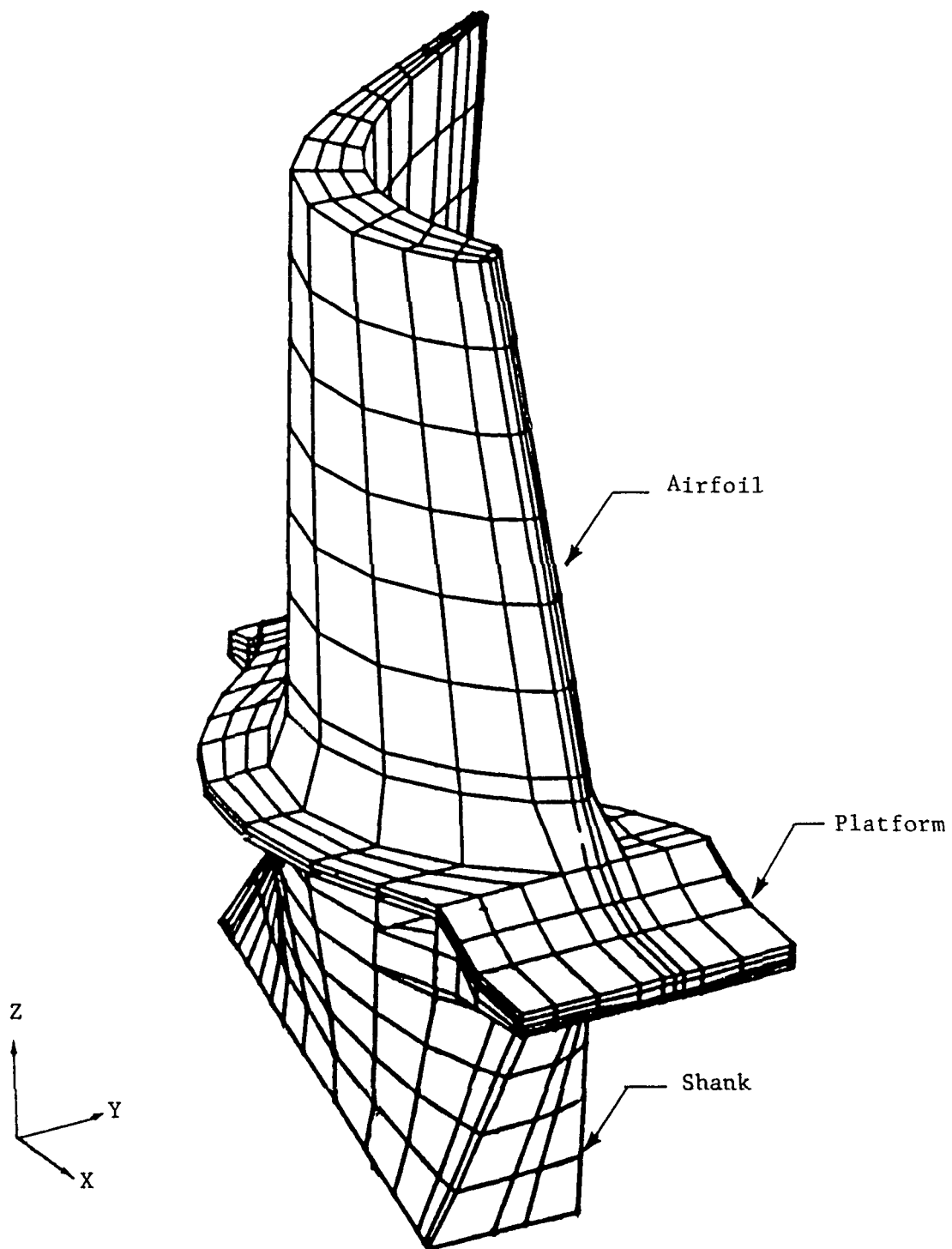

Fig. 2-1a HPFTP First Stage Turbine Blade (F-1) NASTRAN Model
(1575 Nodes, 1025 Elements)

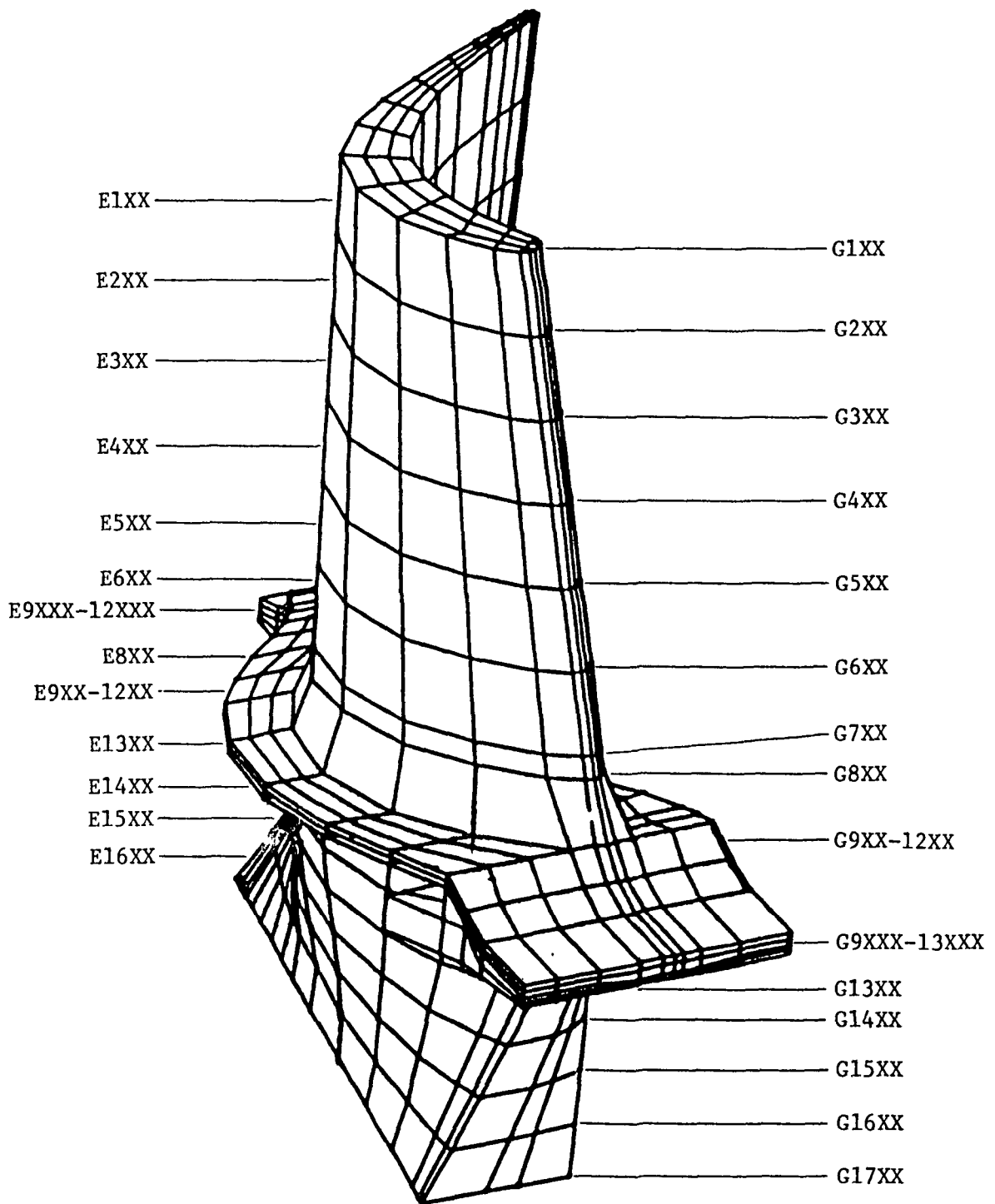

Fig. 2-1b F-1 Element and Grid Prefixes

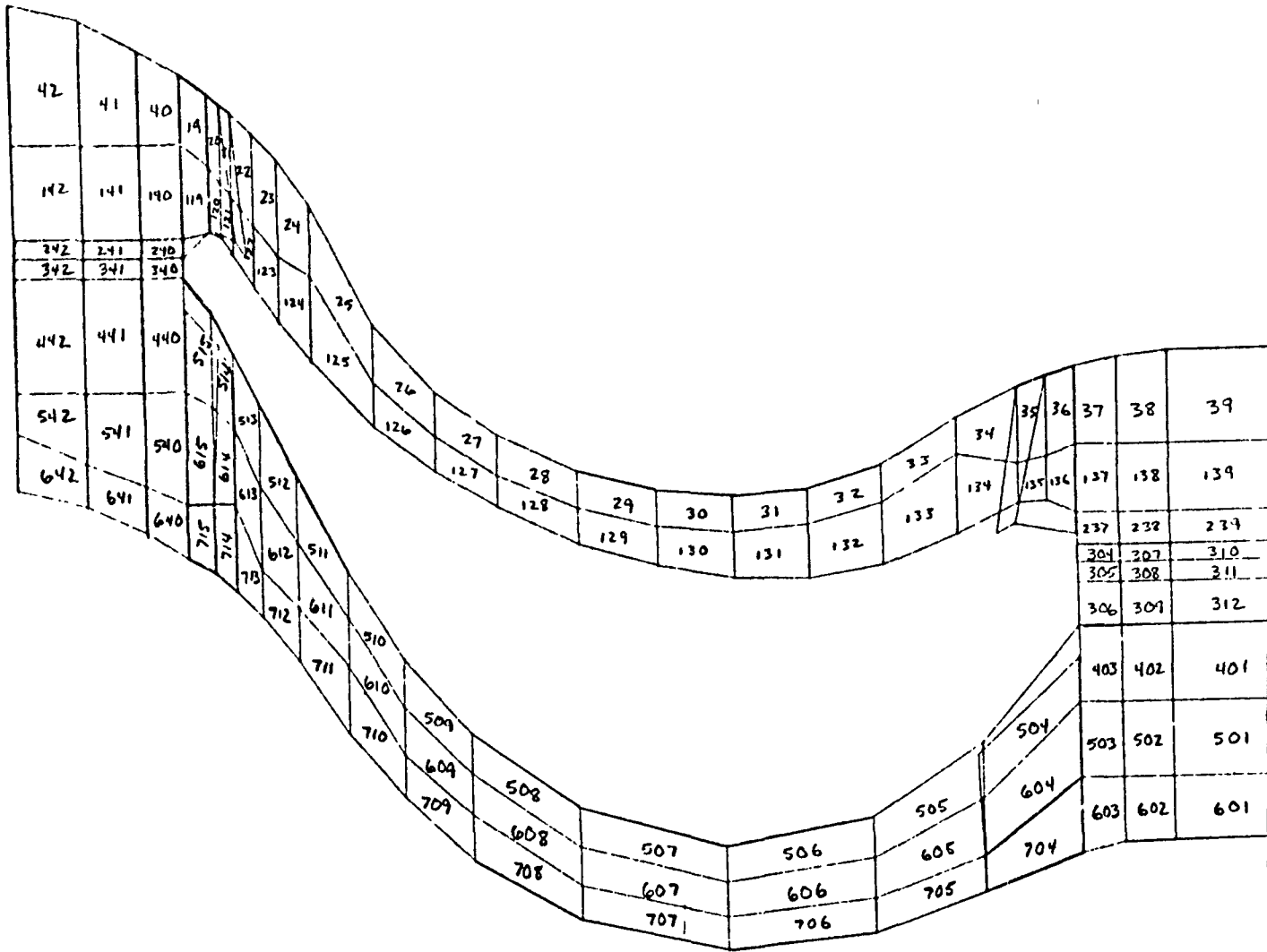

Fig. 2-1c F-1 Platform Element Layout

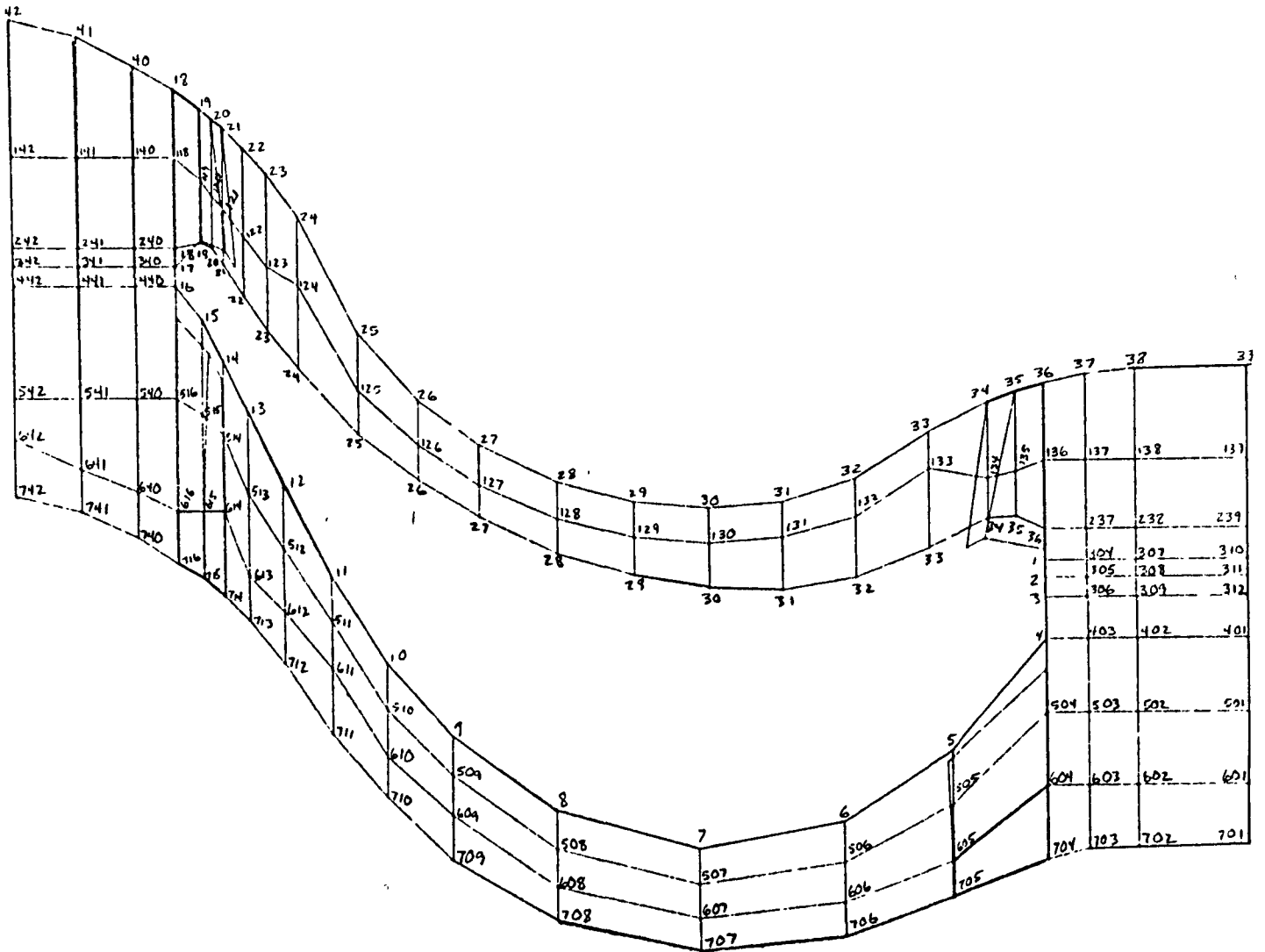

Fig. 2-1d F-1 Platform Grid Layout

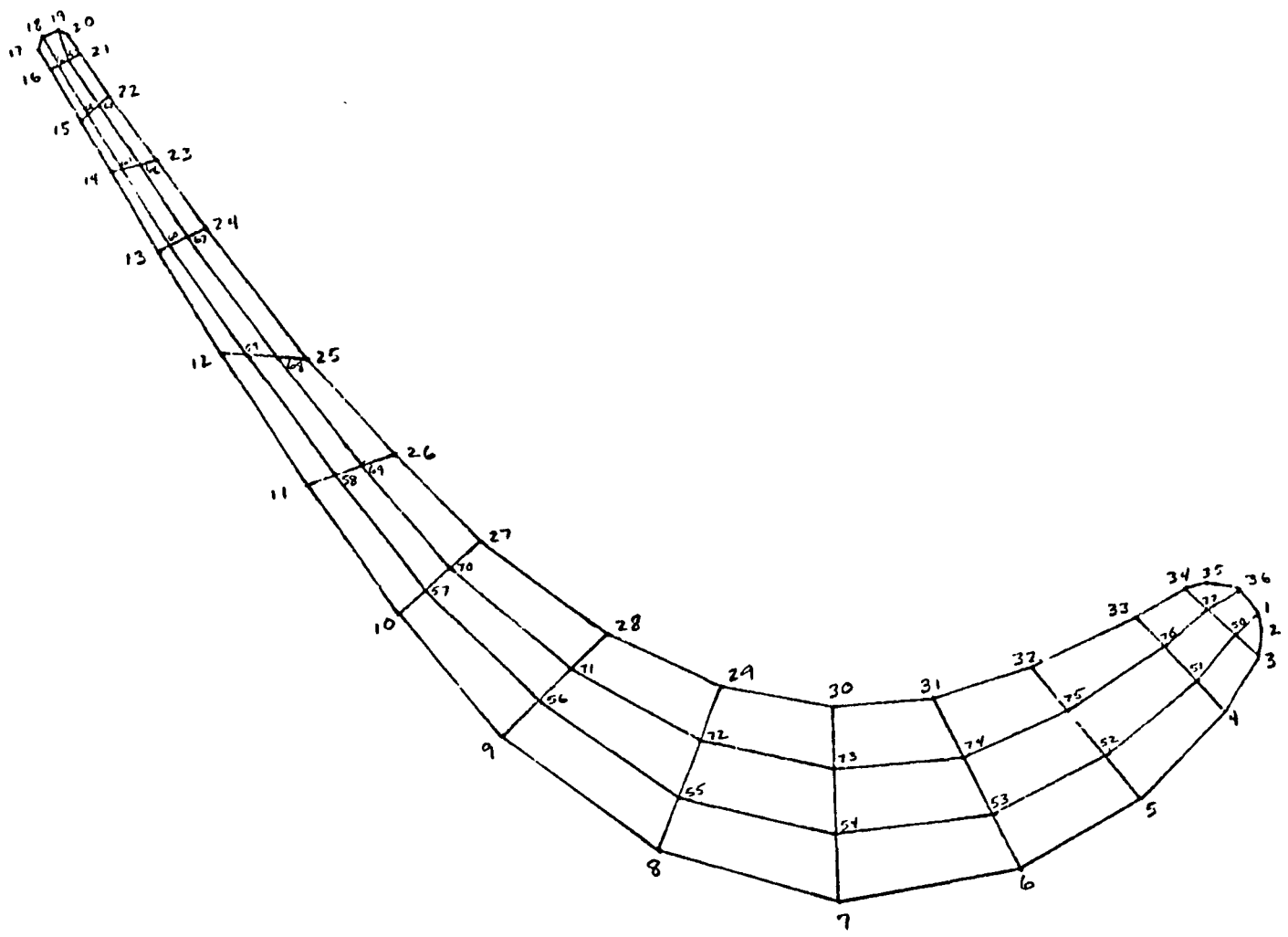

Fig. 2-1e F-1 Airfoil/Shank Grid Layout

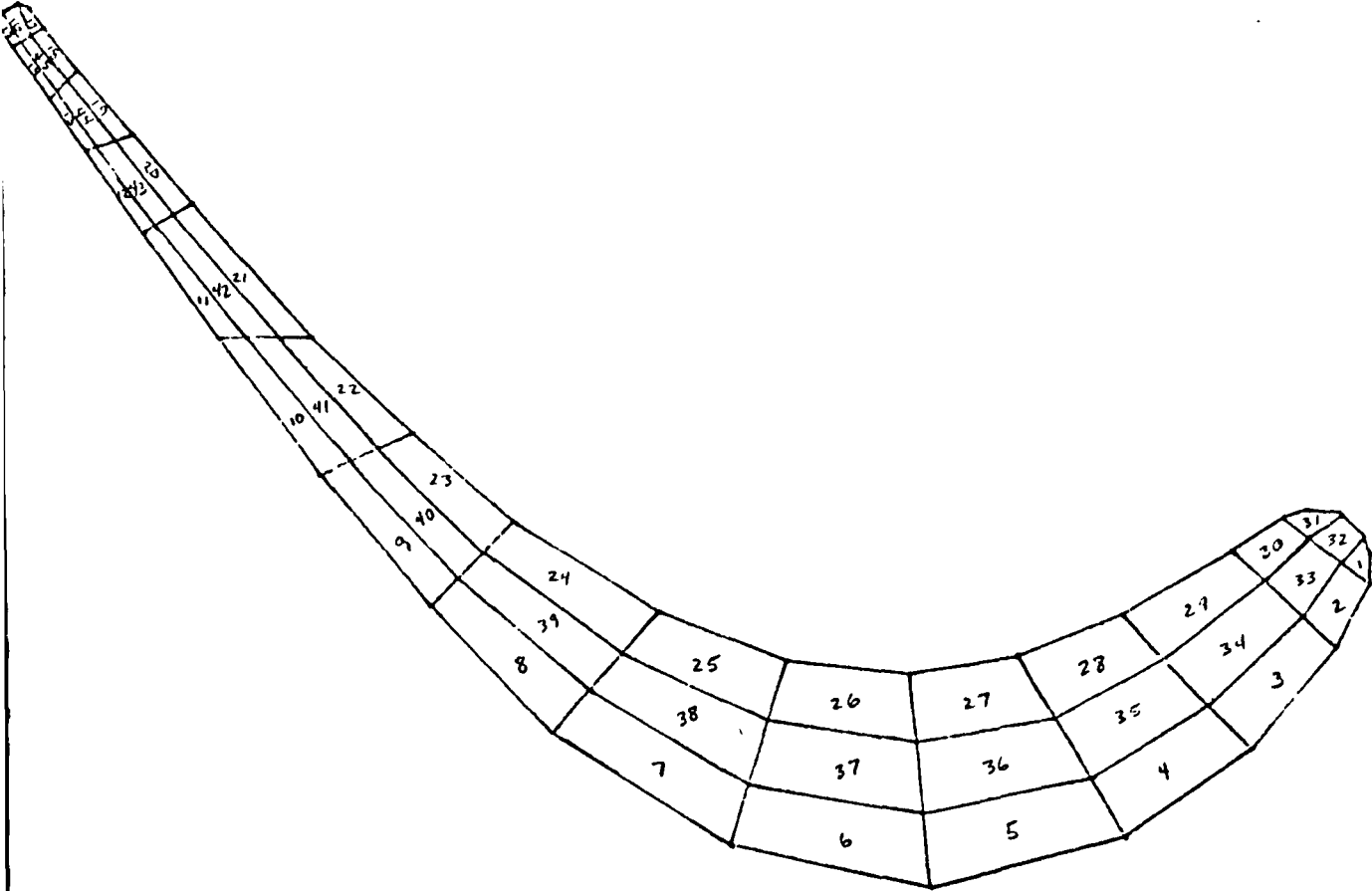

Fig. 2-1f F1 Airfoil/Shank Element Layout

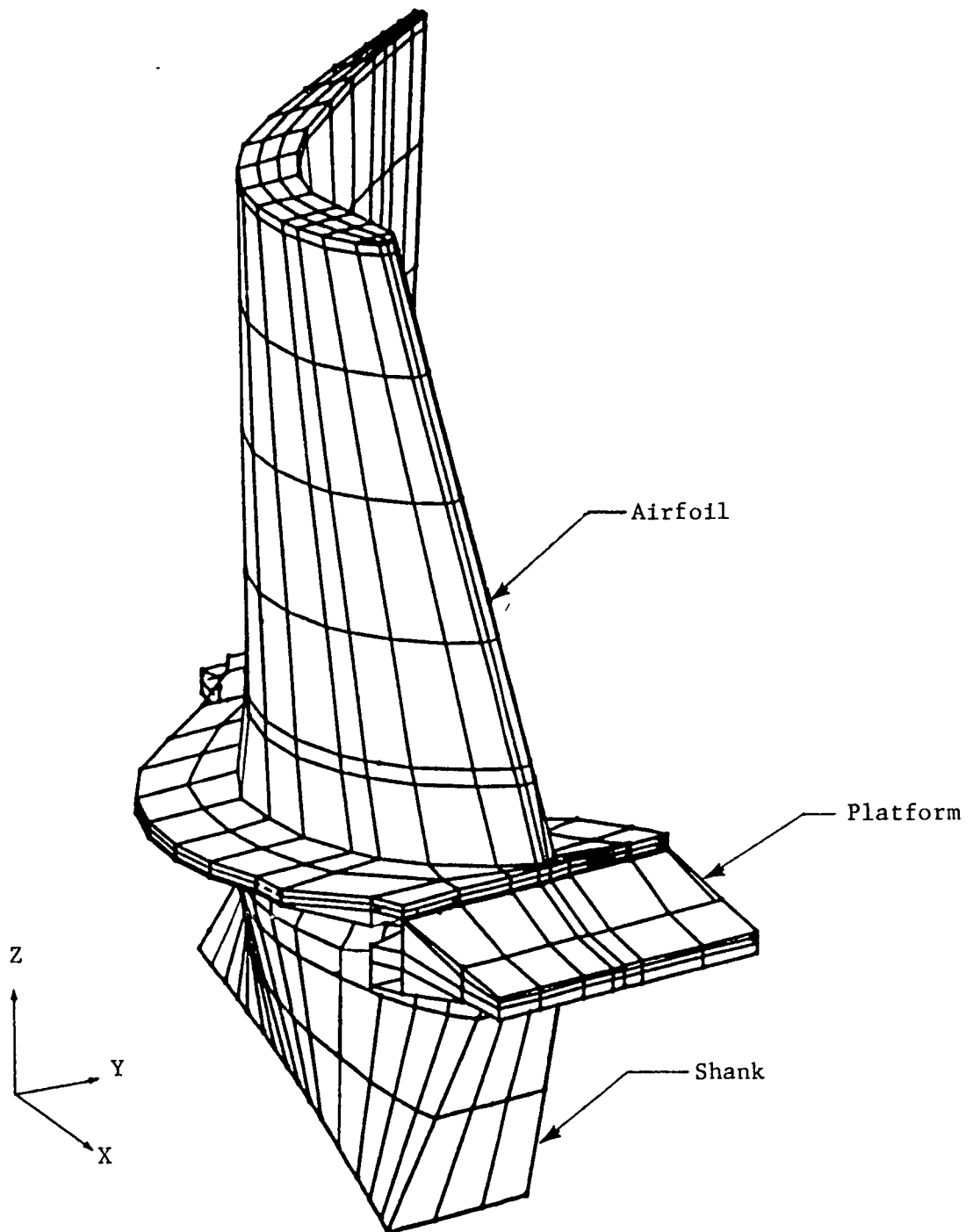

Fig. 2-2a HPFTP Second Stage Turbine Blade (F-2) NASTRAN Model
(1733 Nodes, 1185 Elements)

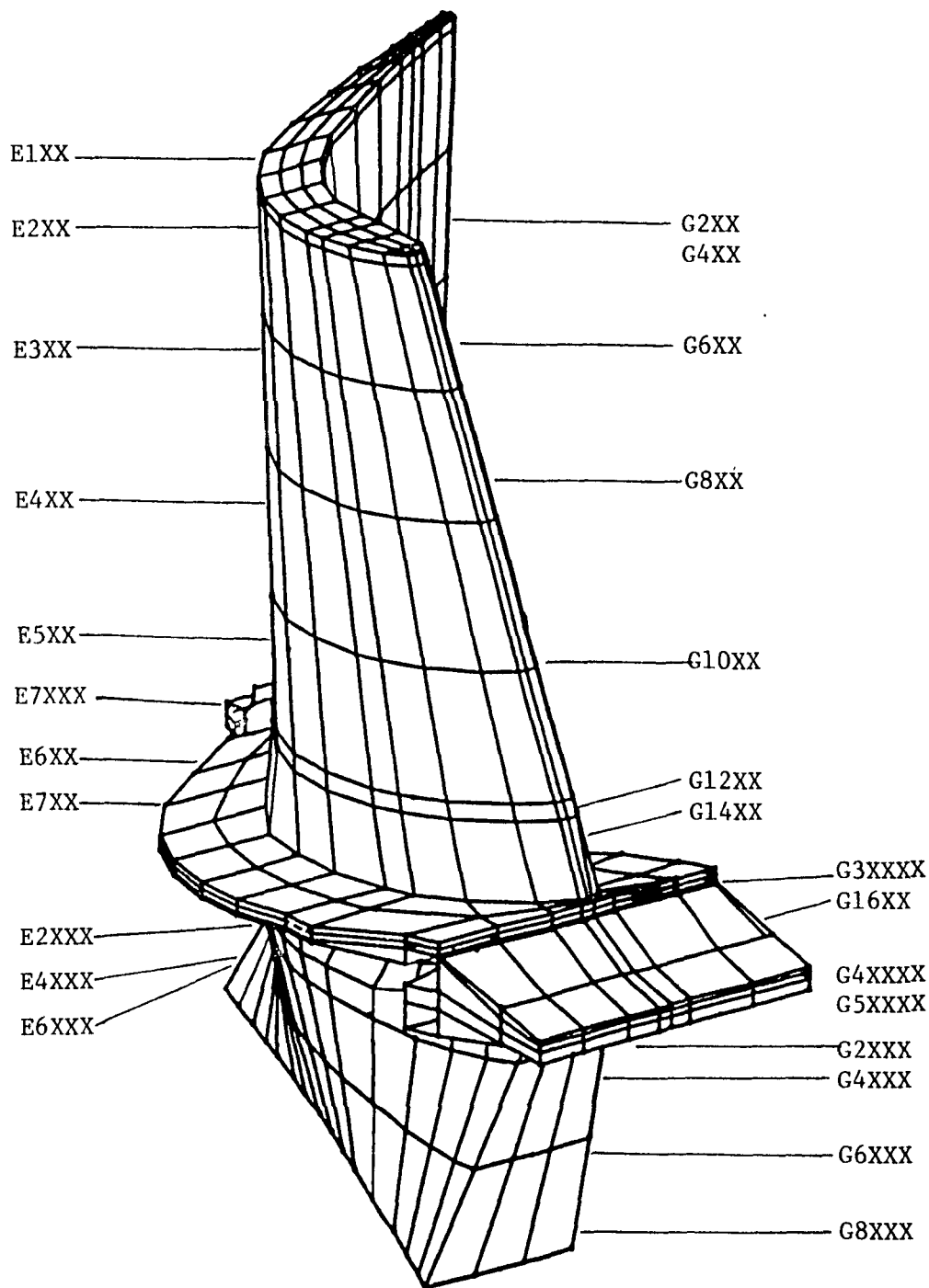

Fig. 2-2b F-2 Element and Grid Prefixes

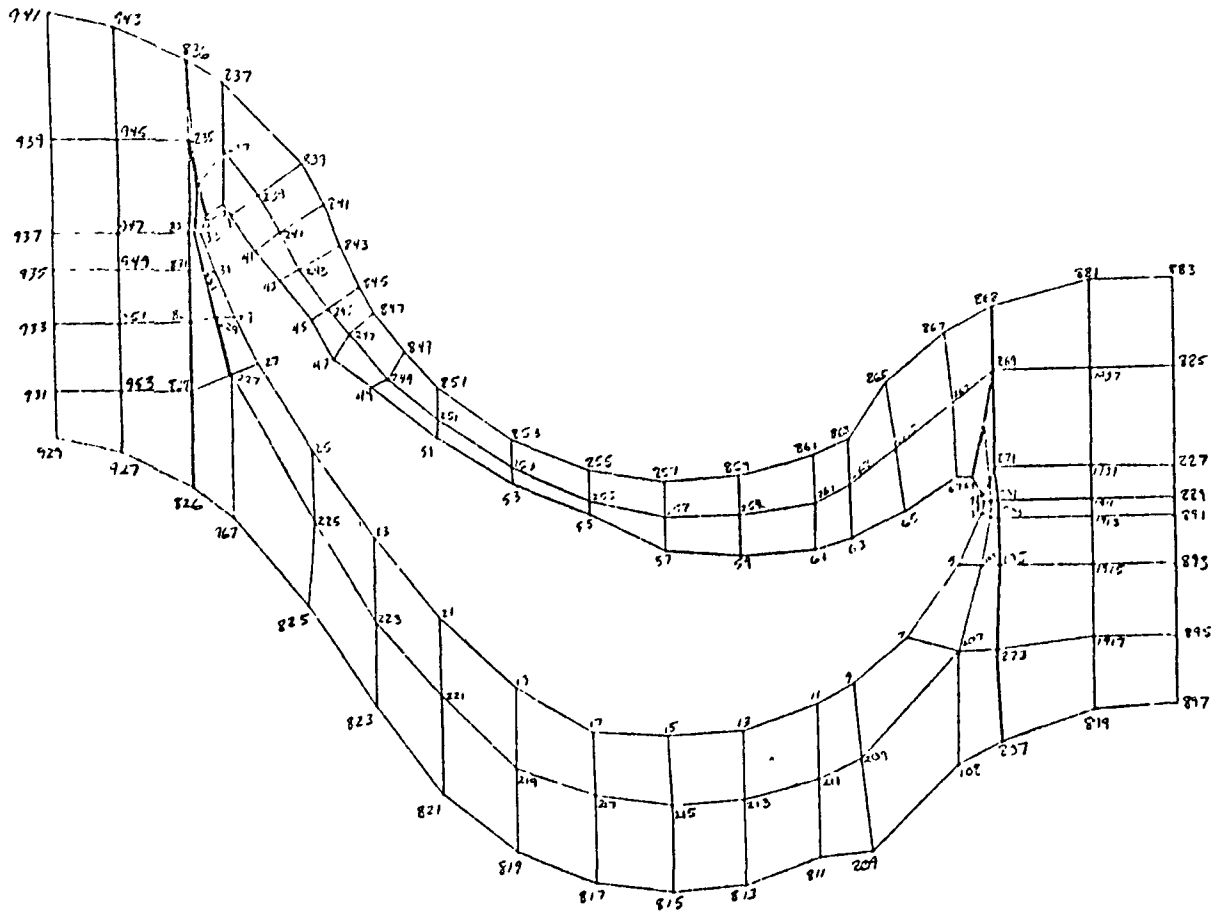

Fig. 2-2c F-2 Platform Grid Layout

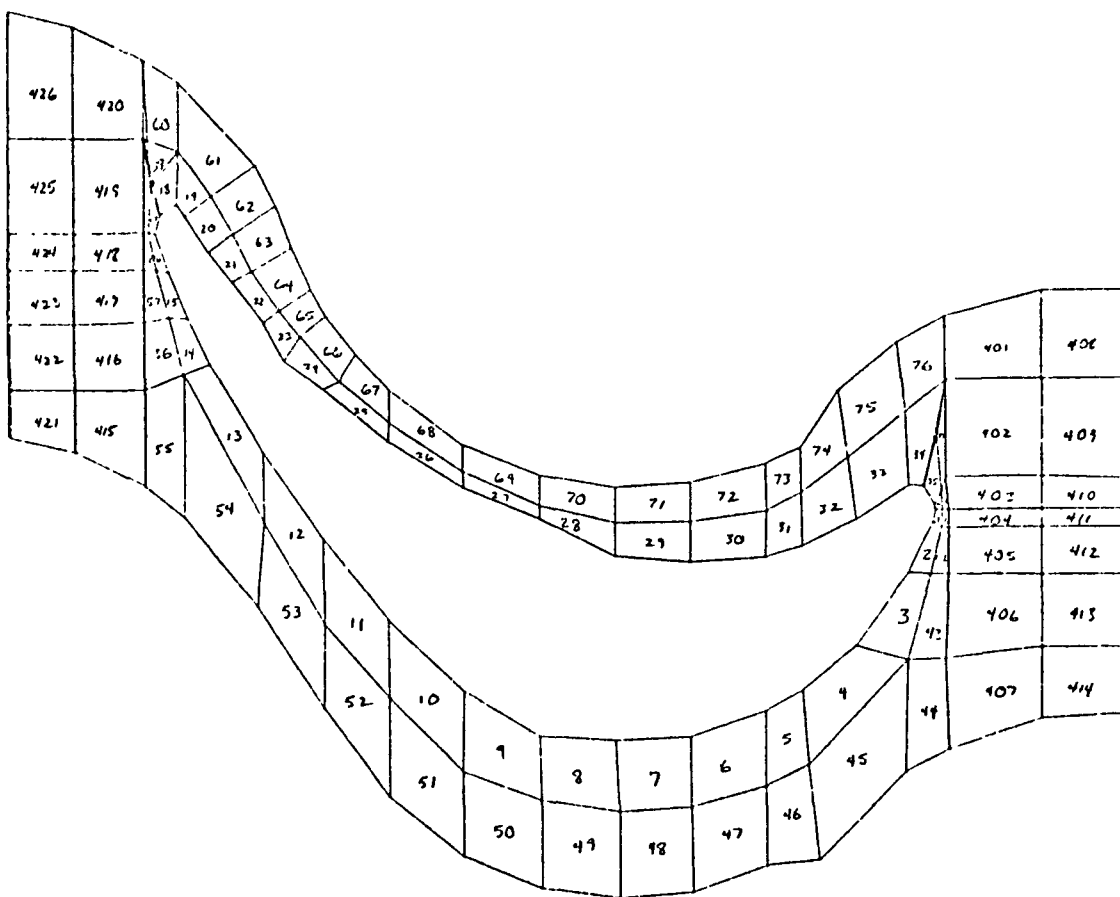

Fig. 2-2d F-2 Platform Element Layout

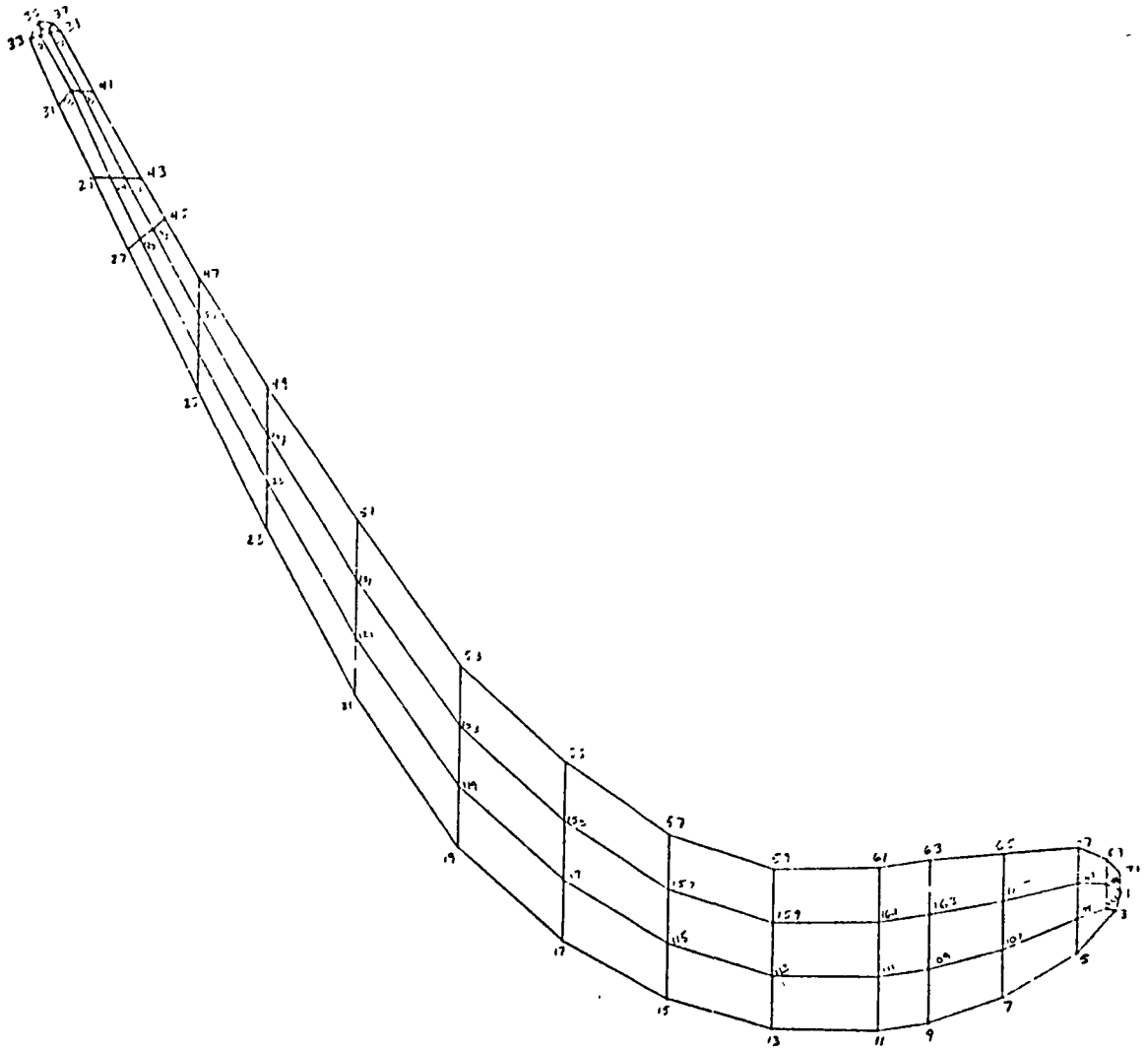

Fig. 2-2e F-2 Airfoil/Shank Grid Layout

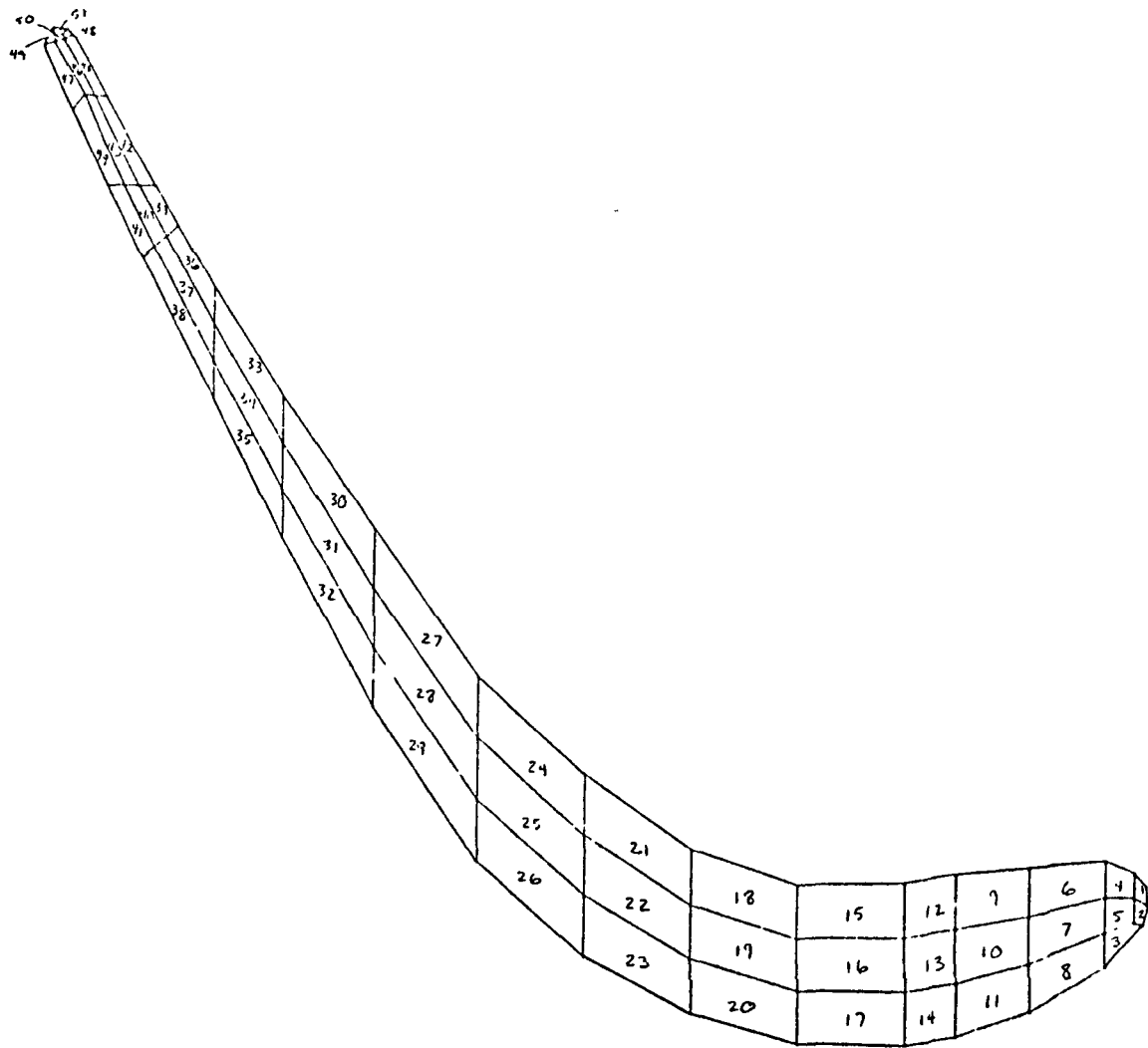

Fig. 2-2f F-2 Airfoil/Shank Element Layout

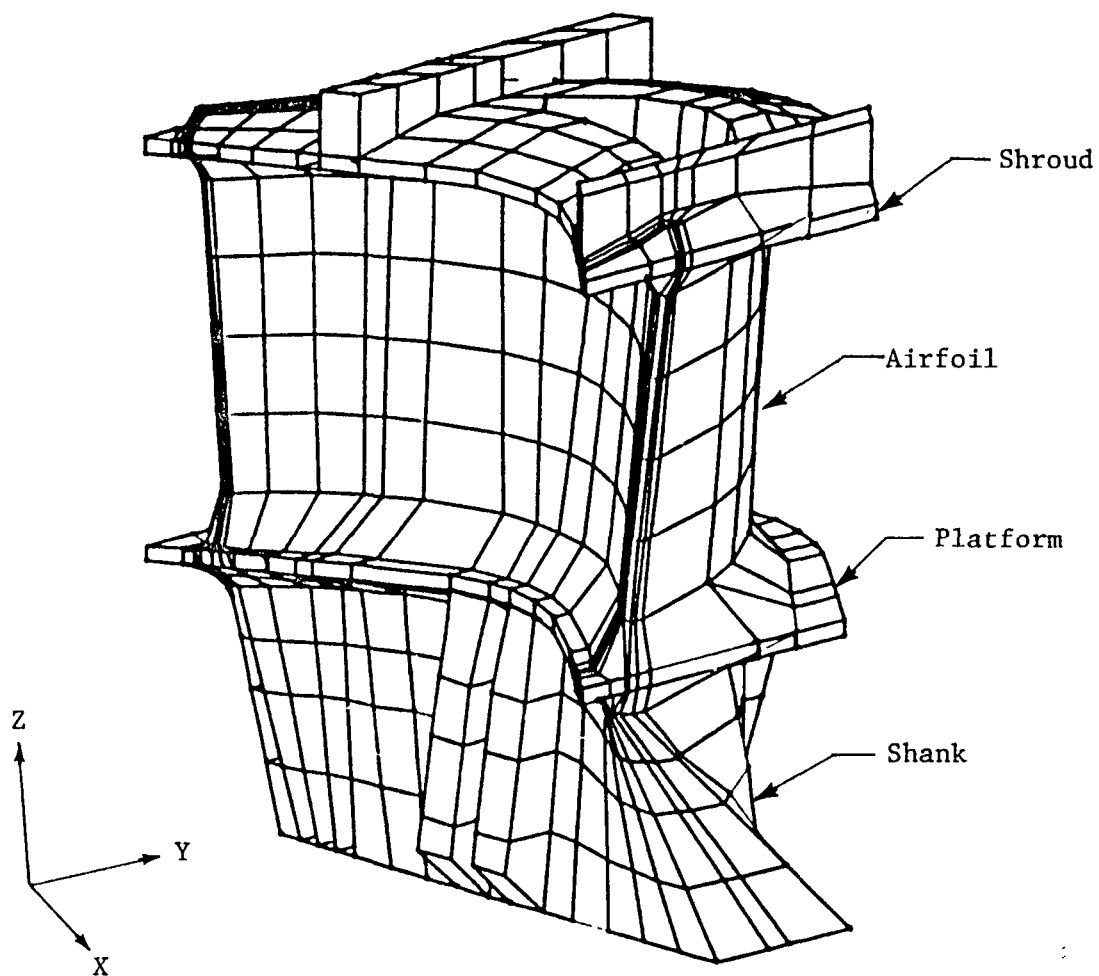

Fig. 2-3a HPOTP First Stage Turbine Blade (0-1) NASTRAN Model (1137 Nodes, 618 Elements)

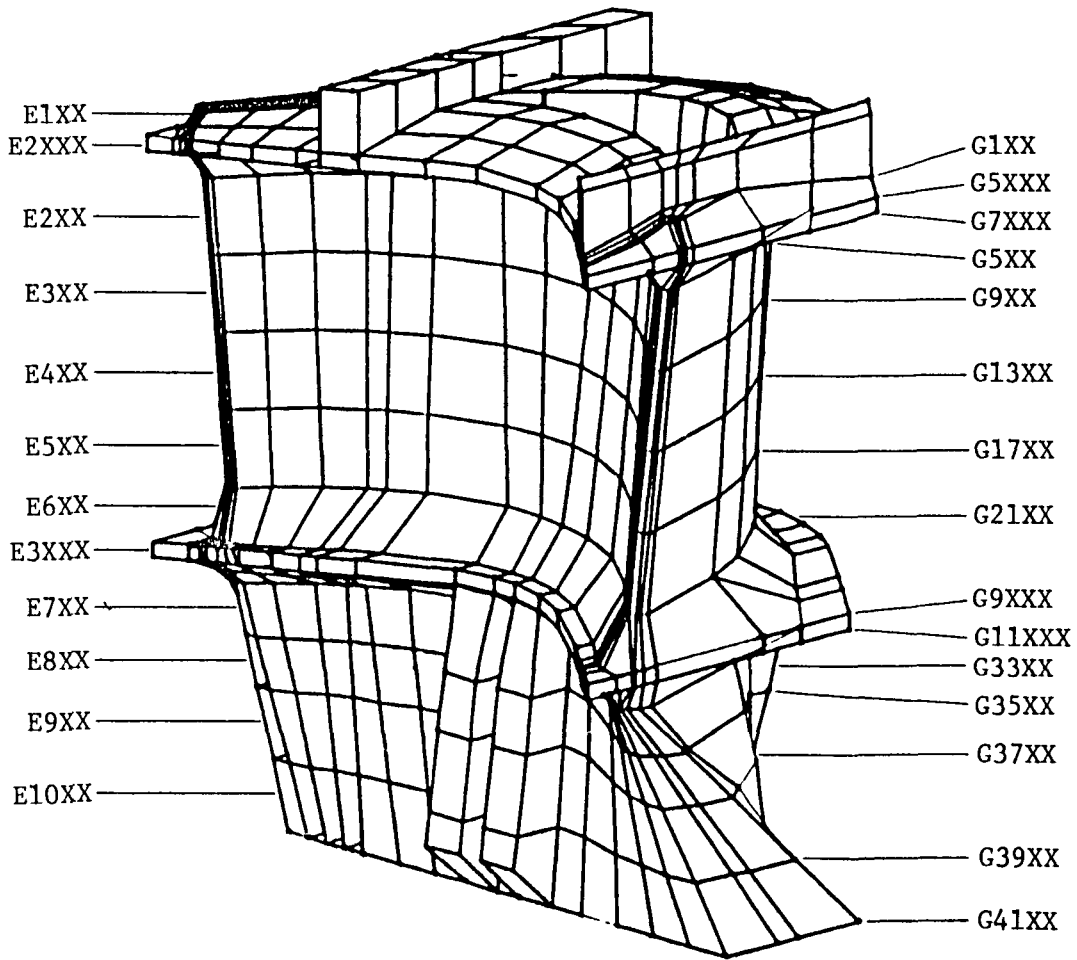

Fig. 2-3b 0-1 Element and Grid Prefixes

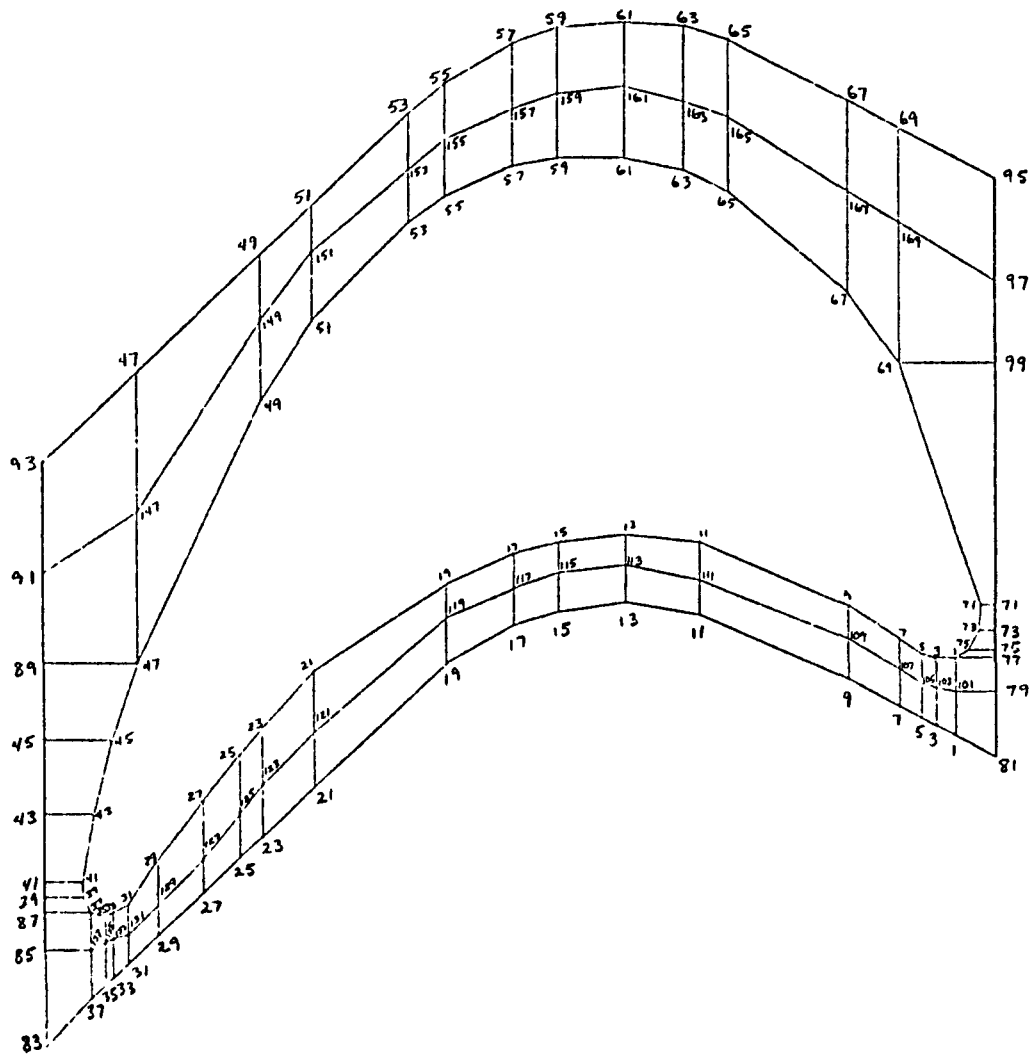

Fig. 2-3c 0-1 Shroud/Platform Grid Layout

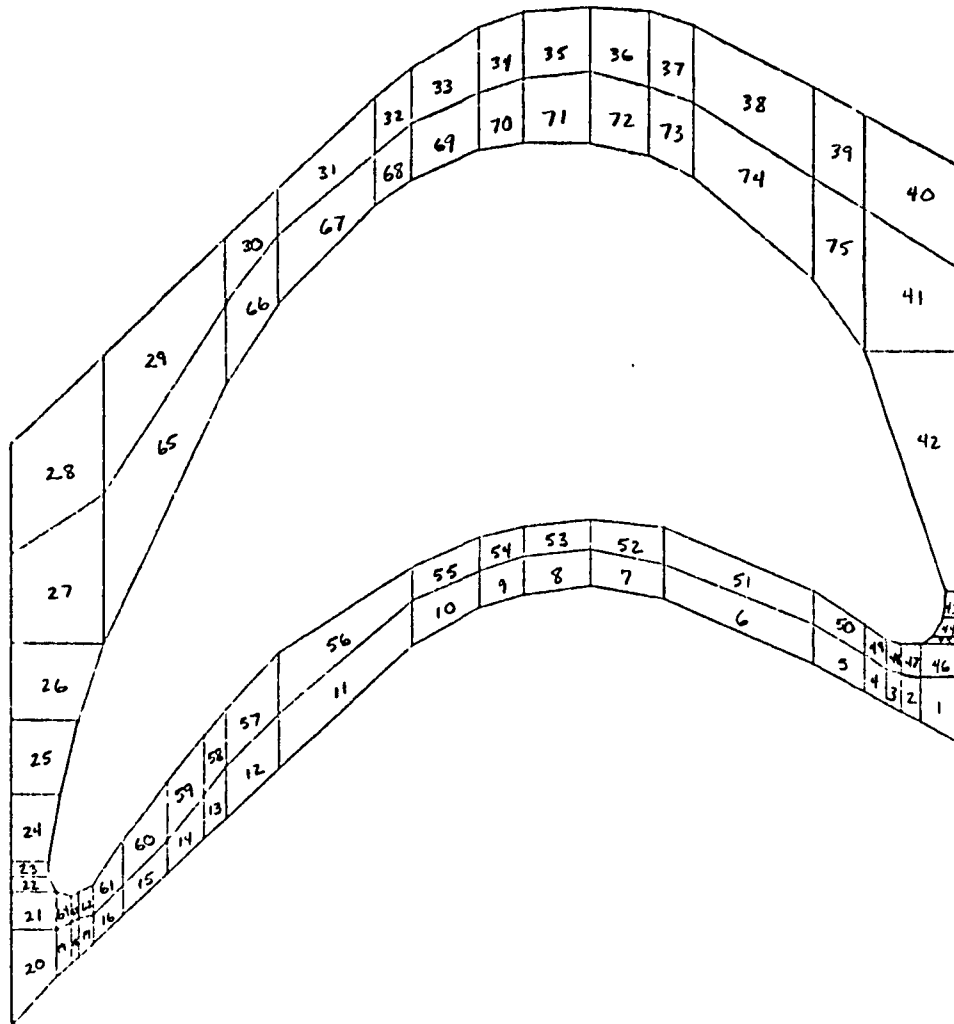

Fig. 2-3d 0-1 Shroud Platform/Element Layout

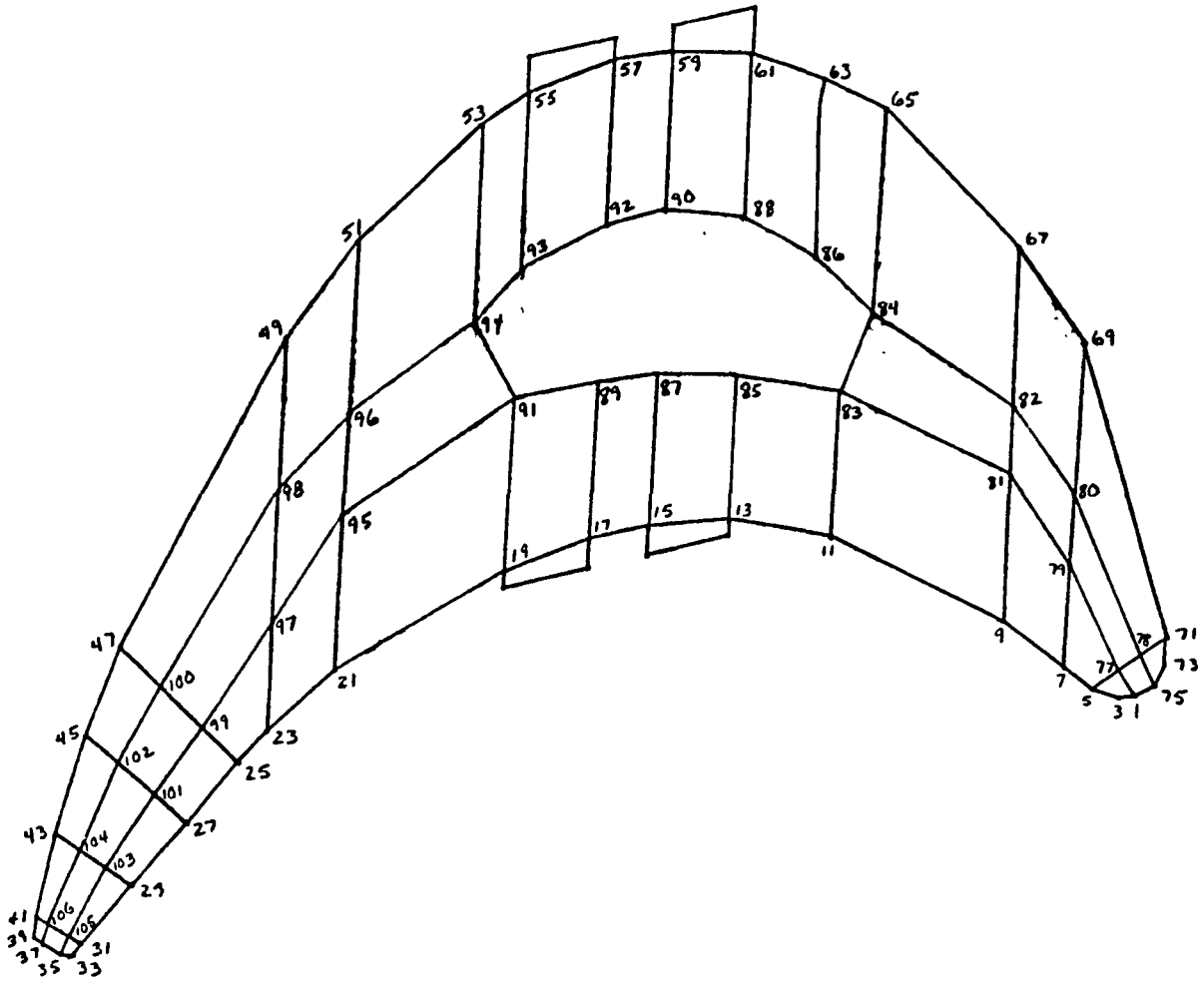

Fig. 2-3e 0-1 Airfoil/Shank Grid Layout

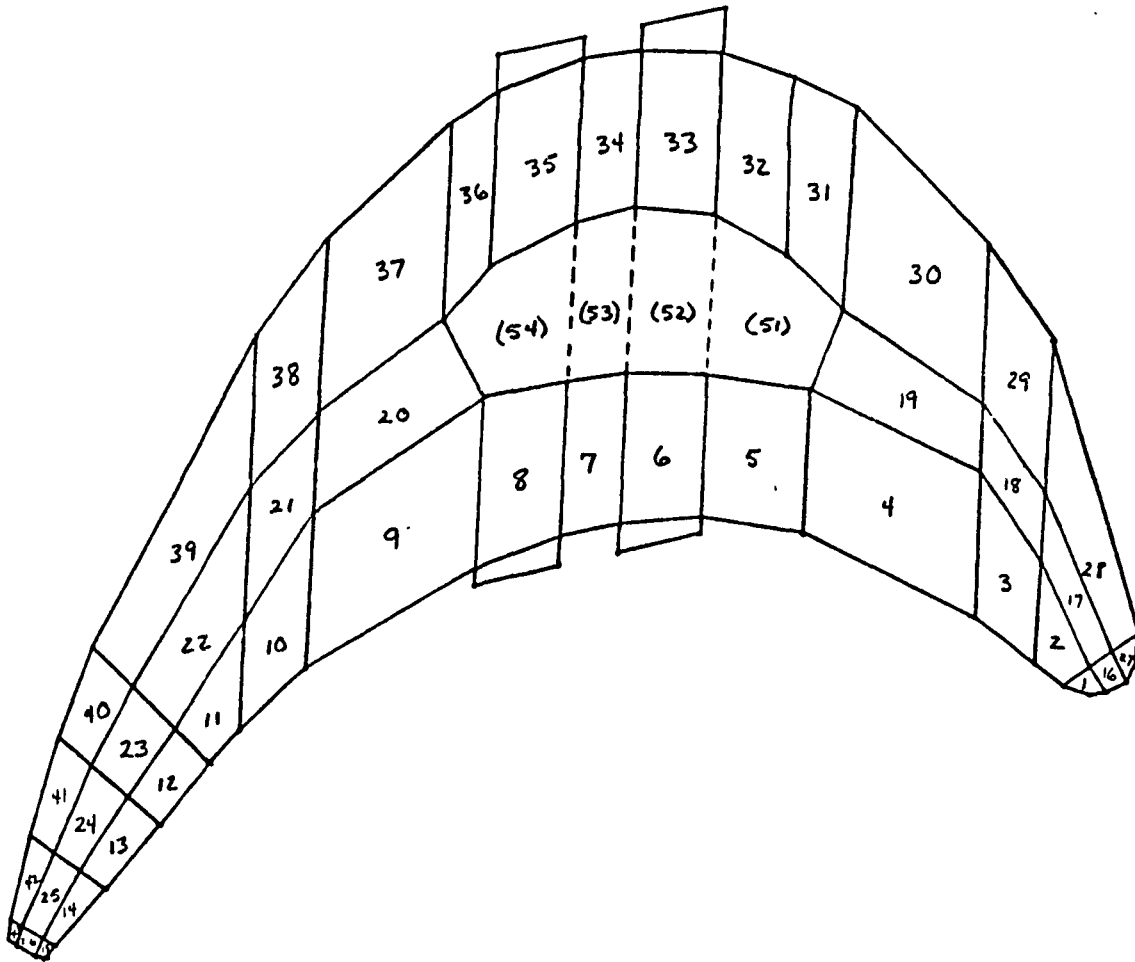

Fig. 2-3f 0-1 Airfoil/Shank Element Layout

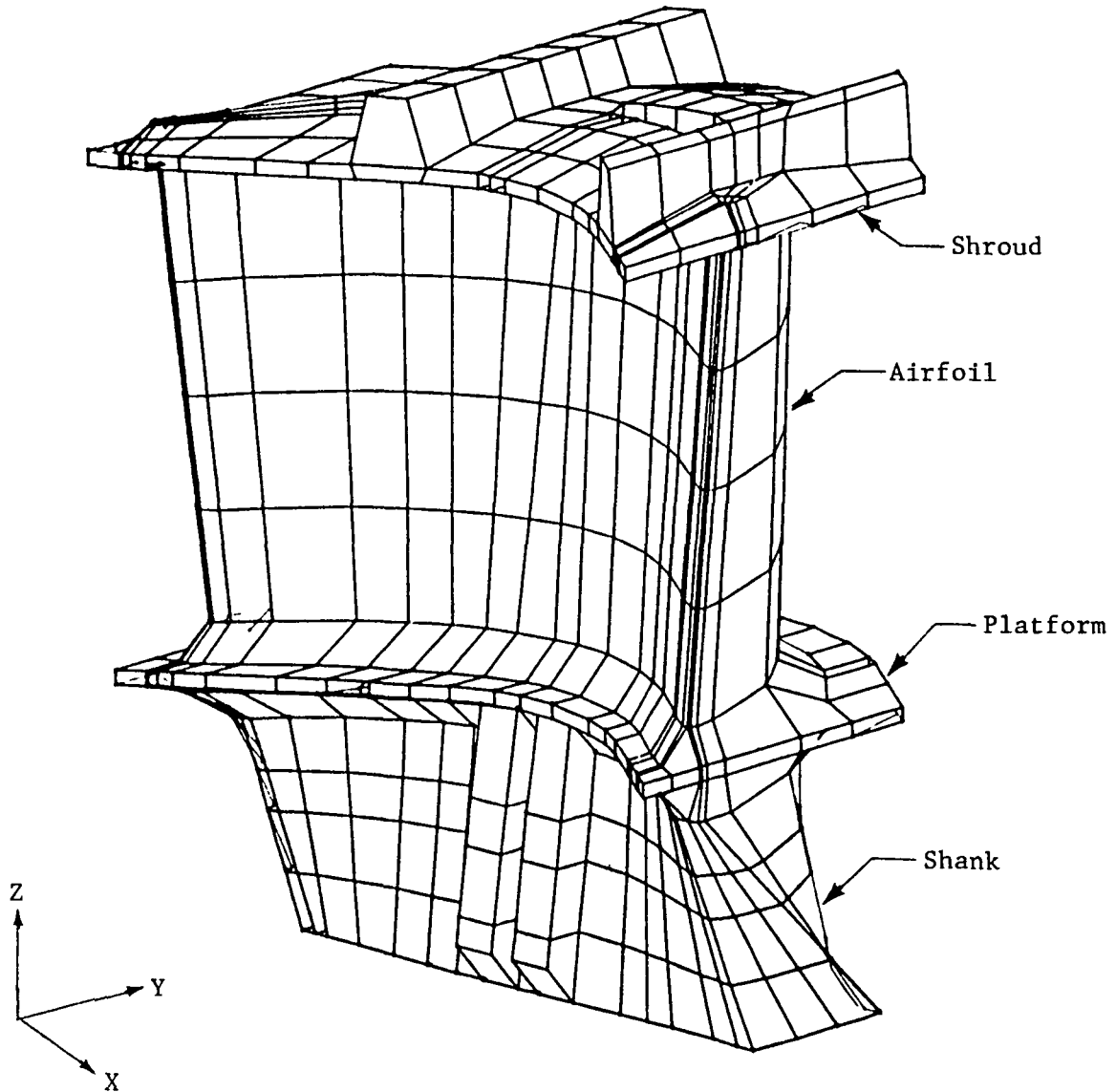

Fig. 2-4a HPOTP Stage Turbine Blade (0-2) NASTRAN Model
(1140 Nodes, 622 Elements)

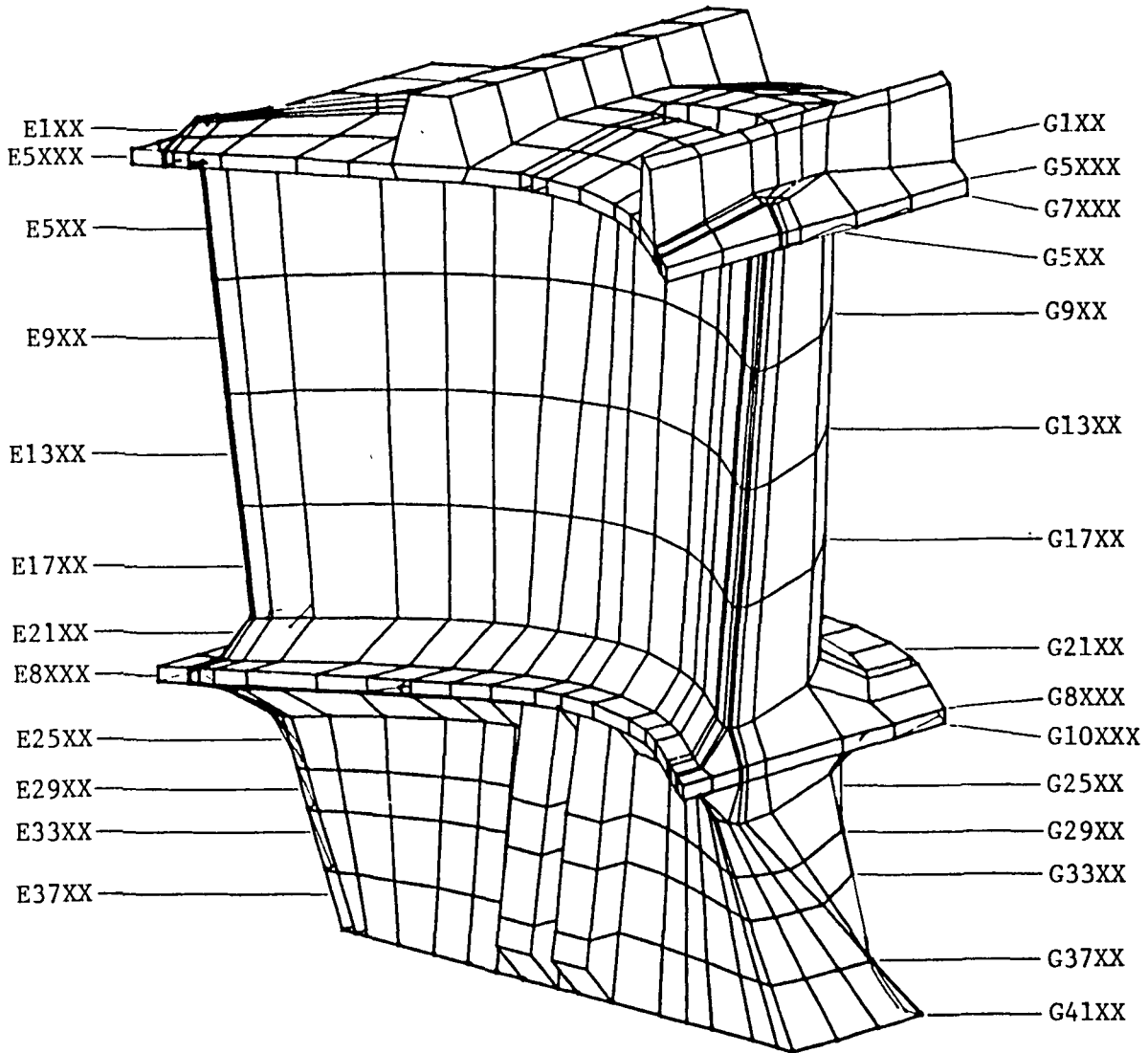

Fig. 2-4b 0-2 Element and Grid Prefixes

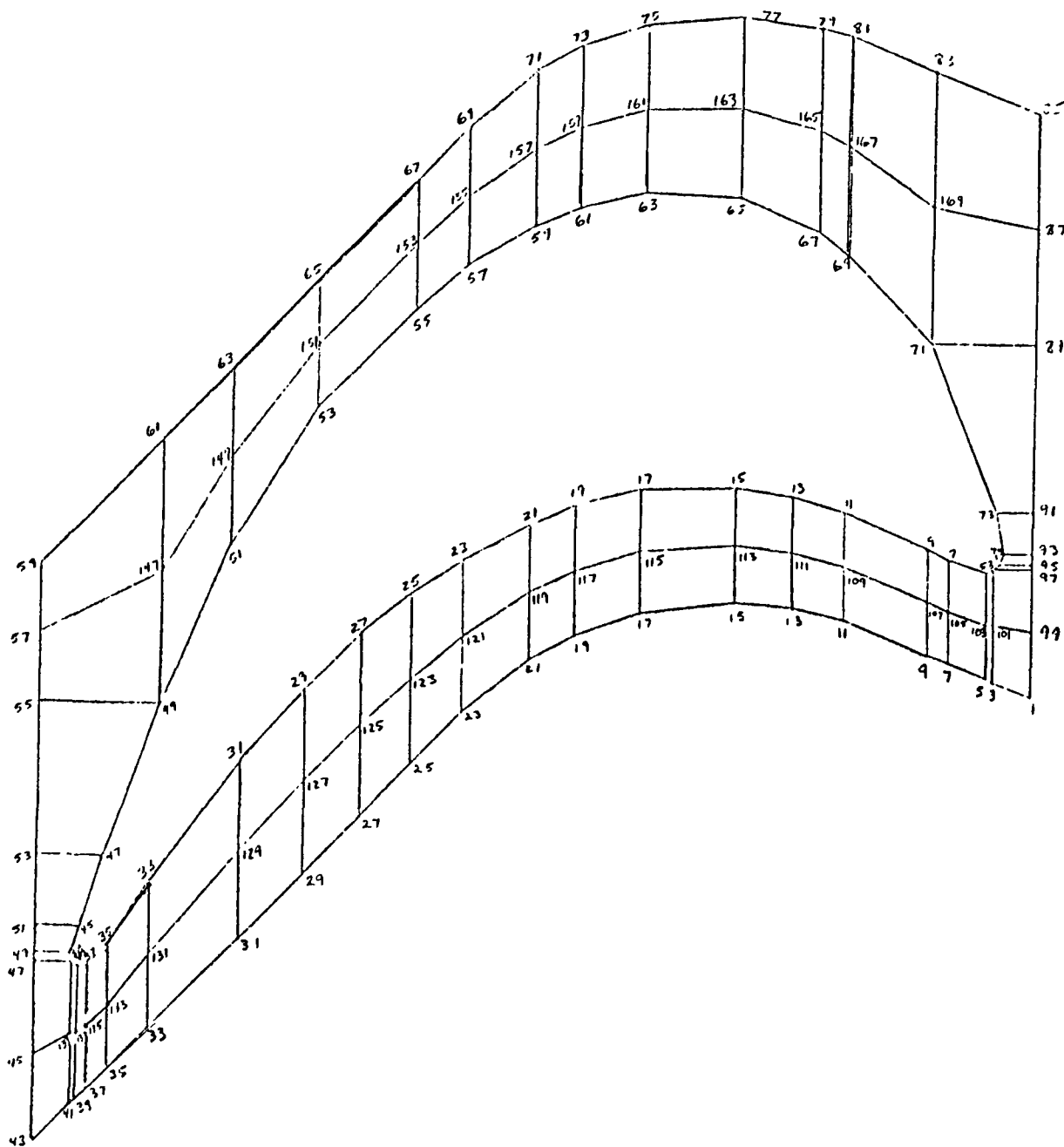

Fig. 2-4c 0-2 Shroud/Platform Grid Layout

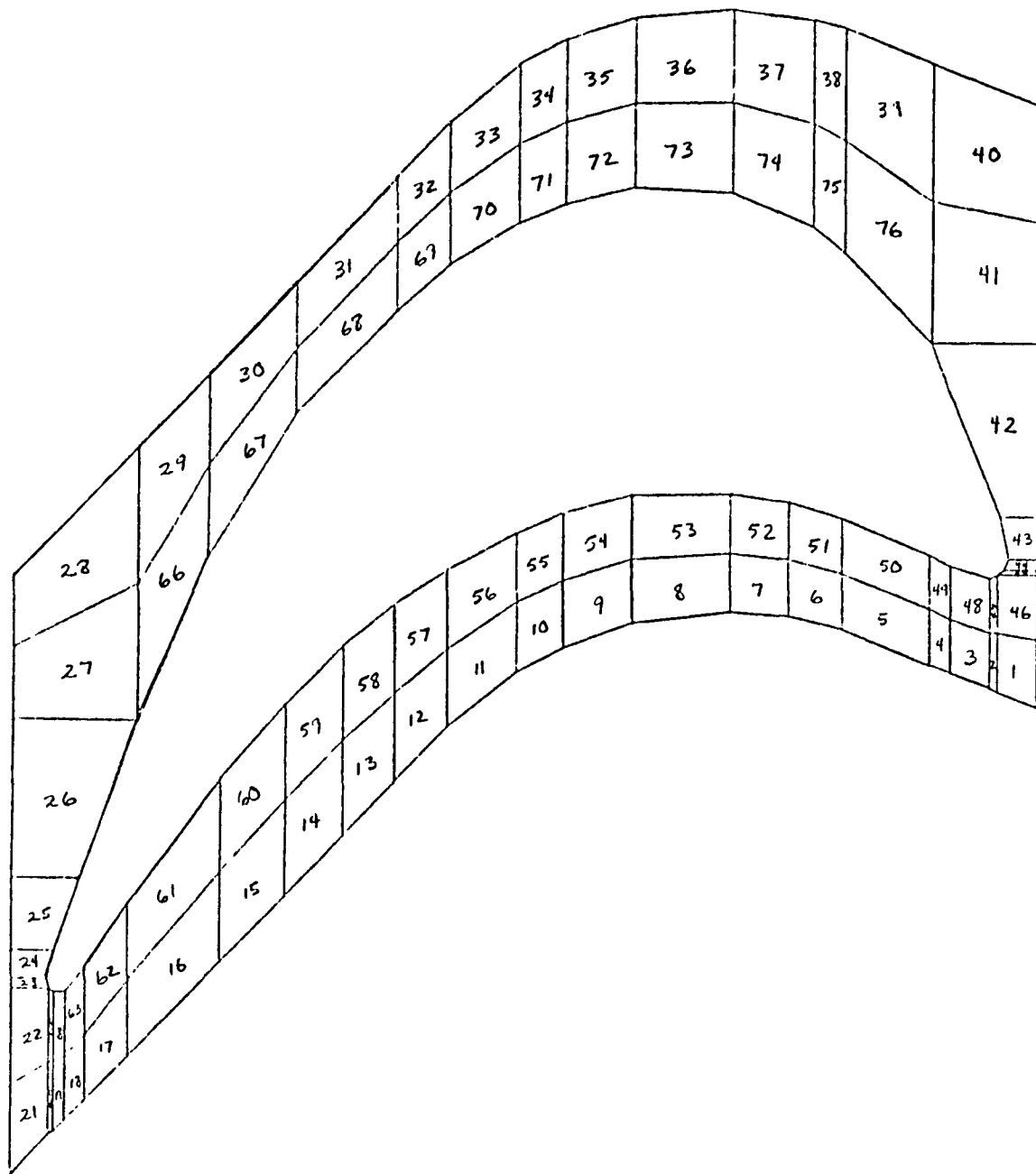

Fig. 2-4d 0-2 Shroud/Platform Element Layout

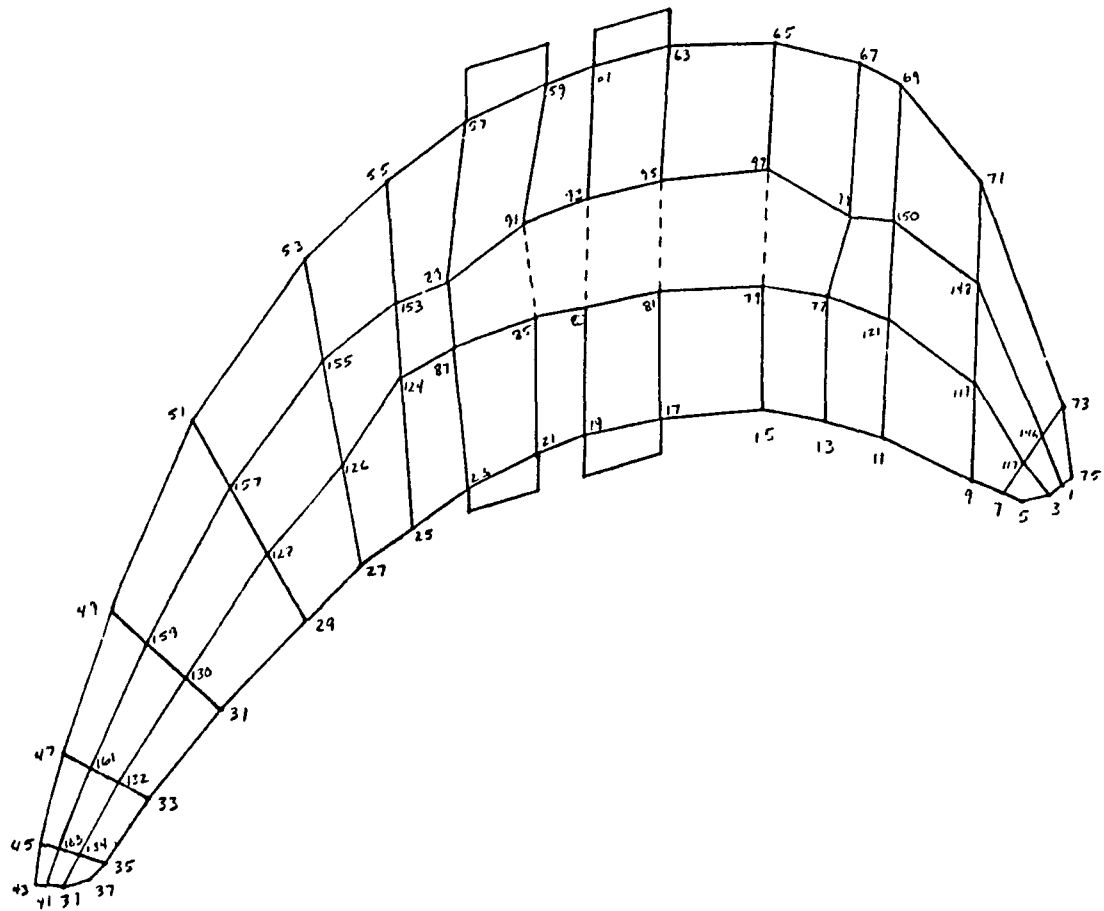

Fig. 2-4e 0-2 Airfoil/Shank Grid Layout

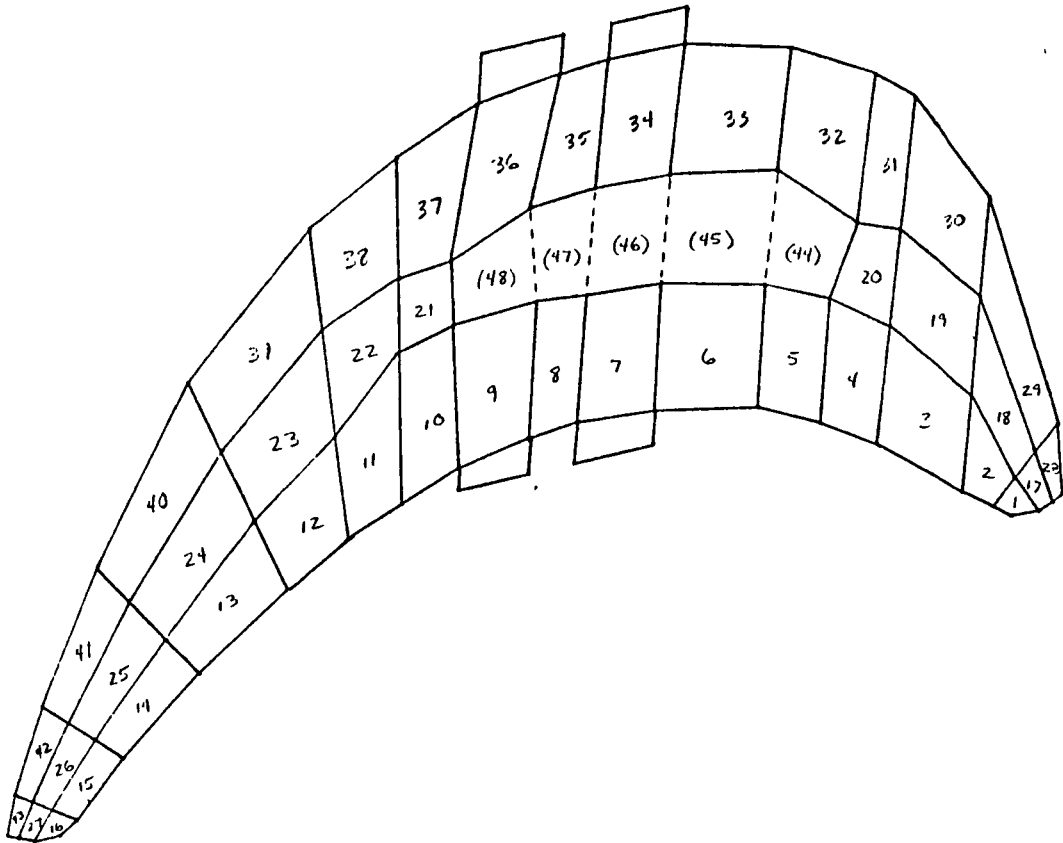

Fig. 2-4f 0-2 Airfoil/Shank Element Layout

2.2 HPFTP FIRST STAGE TURBINE BLADE TEMPERATURES AND STRESSES

Figure 2.2-1 shows the views that are used in generating contour plots for both of the HPFTP blades. Surface temperatures are shown in Figs. 2.2-2 through 2.2-13. Surface stresses are shown in Figs. 2.2-14 through 2.2-49.

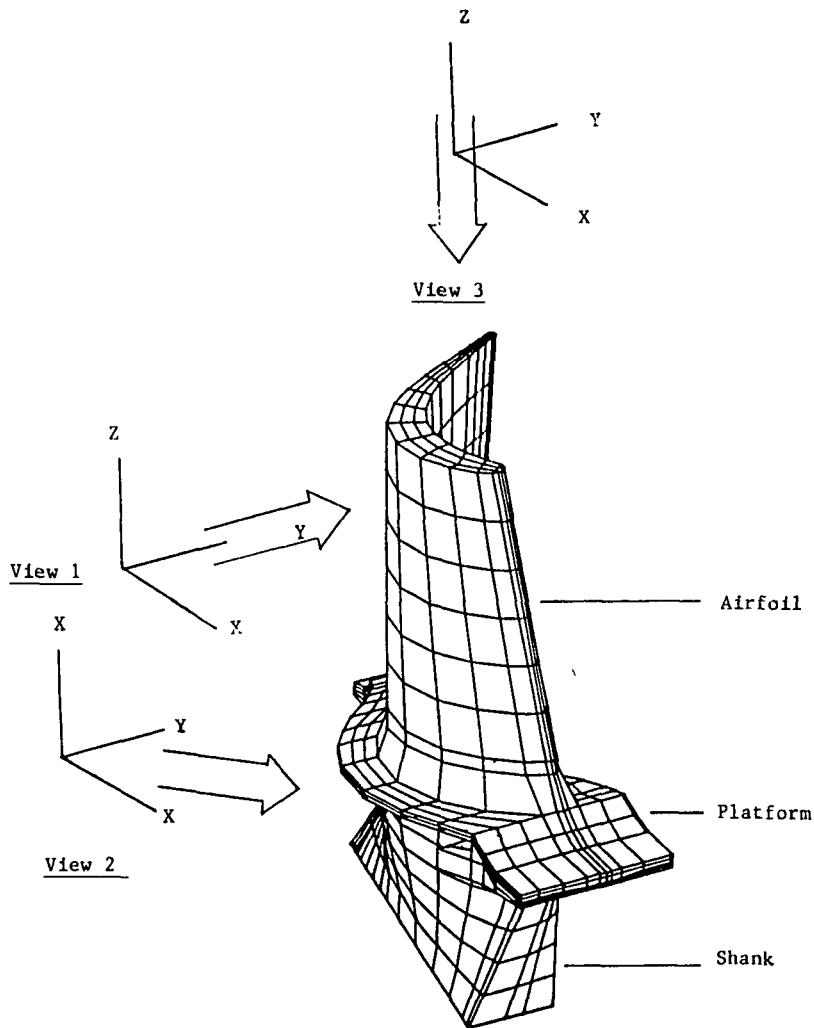
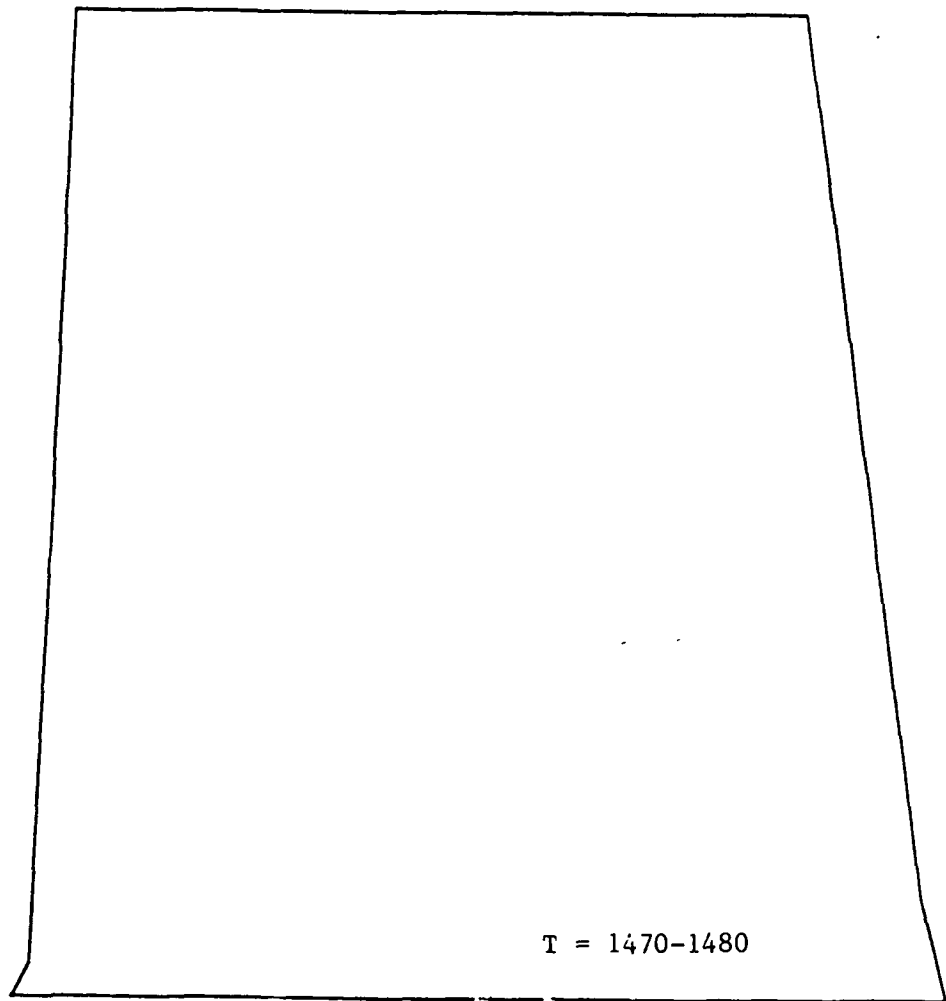
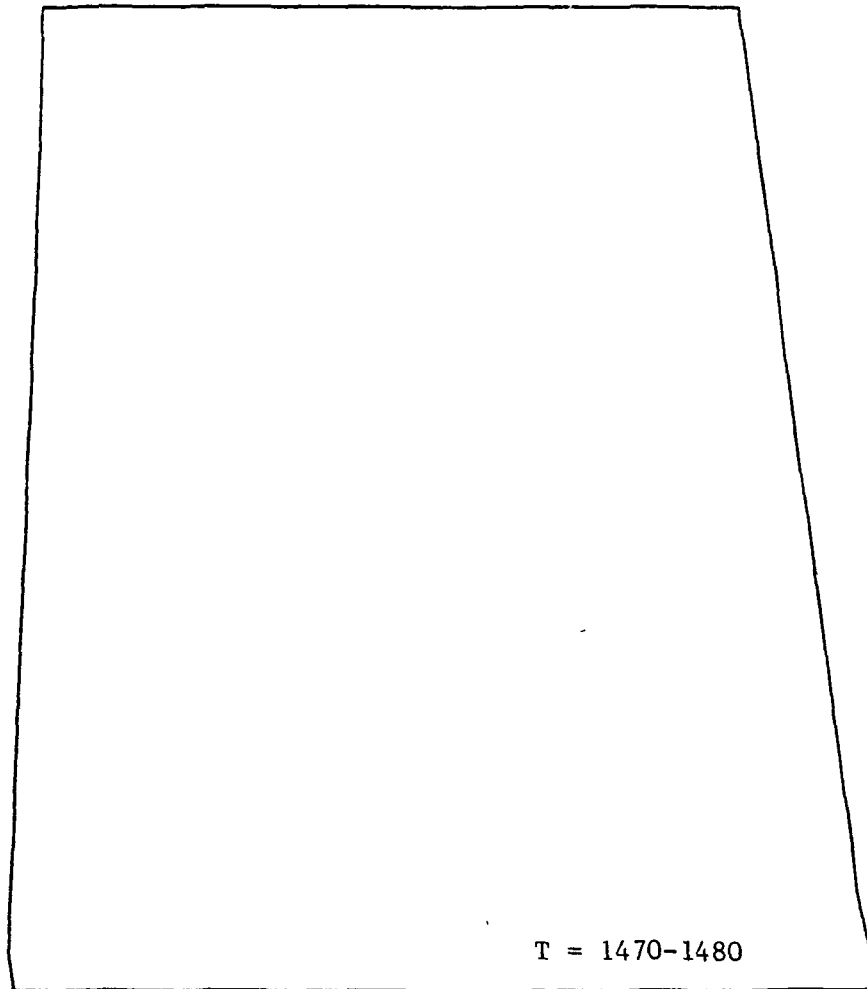

Fig. 2.2-1 Typical Model, Contour Plot Views



1	-3.000000E 02	14	3.500000E 02	27	1.000000E 03
2	-2.500000E 02	15	4.000000E 02	28	1.050000E 03
3	-2.000000E 02	16	4.500000E 02	29	1.100000E 03
4	-1.500000E 02	17	5.000000E 02	30	1.150000E 03
5	-1.000000E 02	18	5.500000E 02	31	1.200000E 03
6	-5.000000E 01	19	6.000000E 02	32	1.250000E 03
7	0.0	20	6.500000E 02	33	1.300000E 03
8	5.000000E 01	21	7.000000E 02	34	1.350000E 03
9	1.000000E 02	22	7.500000E 02	35	1.400000E 03
10	1.500000E 02	23	8.000000E 02	36	1.450000E 03
11	2.000000E 02	24	8.500000E 02	37	1.500000E 03
12	2.500000E 02	25	9.000000E 02	38	1.550000E 03
13	3.000000E 02	26	9.500000E 02	39	1.600000E 03

Fig. 2.2-2 Model F-1, FPL Load, View 1, Airfoil Suction Side Steady State Surface Temperatures (F)



1	-3.000000E 02	14	3.500000E 02	27	1.000000E 03
2	-2.500000E 02	15	4.000000E 02	28	1.050000E 03
3	-2.000000E 02	16	4.500000E 02	29	1.100000E 03
4	-1.500000E 02	17	5.000000E 02	30	1.150000E 03
5	-1.000000E 02	18	5.500000E 02	31	1.200000E 03
6	-5.000000E 01	19	6.000000E 02	32	1.250000E 03
7	0.0	20	6.500000E 02	33	1.300000E 03
8	5.000000E 01	21	7.000000E 02	34	1.350000E 03
9	1.000000E 02	22	7.500000E 02	35	1.400000E 03
10	1.500000E 02	23	8.000000E 02	36	1.450000E 03
11	2.000000E 02	24	8.500000E 02	37	1.500000E 03
12	2.500000E 02	25	9.000000E 02	38	1.550000E 03
13	3.000000E 02	26	9.500000E 02	39	1.600000E 03

Fig. 2.2-3 Model F-1, FPL Load, View 1, Airfoil Pressure Side Steady State Surface Temperatures (F)

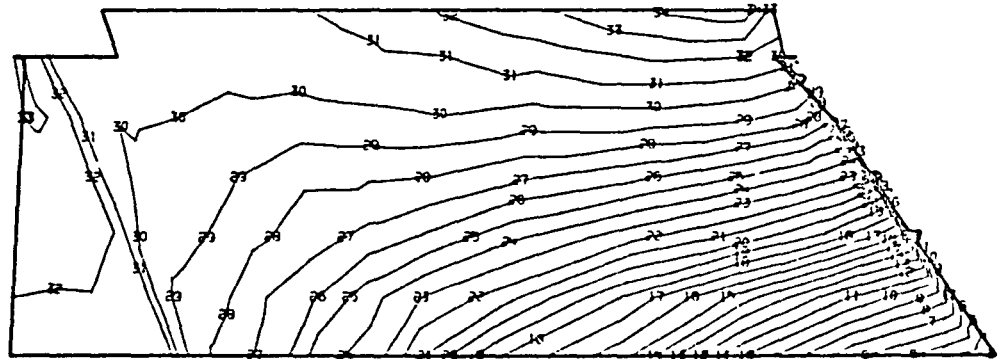

1	-3.000000E 02	14	3.500000E 02	27	1.000000E 03
2	-2.500000E 02	15	4.000000E 02	28	1.050000E 03
3	-2.000000E 02	16	4.500000E 02	29	1.100000E 03
4	-1.500000E 02	17	5.000000E 02	30	1.150000E 03
5	-1.000000E 02	18	5.500000E 02	31	1.200000E 03
6	-5.000000E 01	19	6.000000E 02	32	1.250000E 03
7	0.0	20	6.500000E 02	33	1.300000E 03
8	5.000000E 01	21	7.000000E 02	34	1.350000E 03
9	1.000000E 02	22	7.500000E 02	35	1.400000E 03
10	1.500000E 02	23	8.000000E 02	36	1.450000E 03
11	2.000000E 02	24	8.500000E 02	37	1.500000E 03
12	2.500000E 02	25	9.000000E 02	38	1.550000E 03
13	3.000000E 02	26	9.500000E 02	39	1.600000E 03

Fig. 2.2-4 Model F-1, FPL Load, View 2, Shank Suction Side Steady State Surface Temperatures (F)

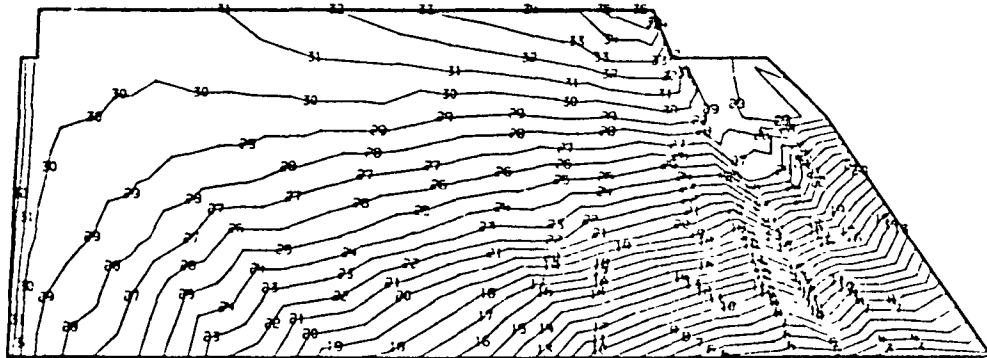

1	-3.000000E 02	14	3.500000E 02	27	1.000000E 03
2	-2.500000E 02	15	4.000000E 02	28	1.050000E 03
3	-2.000000E 02	16	4.500000E 02	29	1.100000E 03
4	-1.500000E 02	17	5.000000E 02	30	1.150000E 03
5	-1.000000E 02	18	5.500000E 02	31	1.200000E 03
6	-5.000000E 01	19	6.000000E 02	32	1.250000E 03
7	0.0	20	6.500000E 02	33	1.300000E 03
8	5.000000E 01	21	7.000000E 02	34	1.350000E 03
9	1.000000E 02	22	7.500000E 02	35	1.400000E 03
10	1.500000E 02	23	8.000000E 02	36	1.450000E 03
11	2.000000E 02	24	8.500000E 02	37	1.500000E 03
12	2.500000E 02	25	9.000000E 02	38	1.550000E 03
13	3.000000E 02	26	9.500000E 02	39	1.600000E 03

Fig. 2.2-5 Model F-1, FPL Load, View 2, Shank Pressure Side Steady State Surface Temperatures (F)

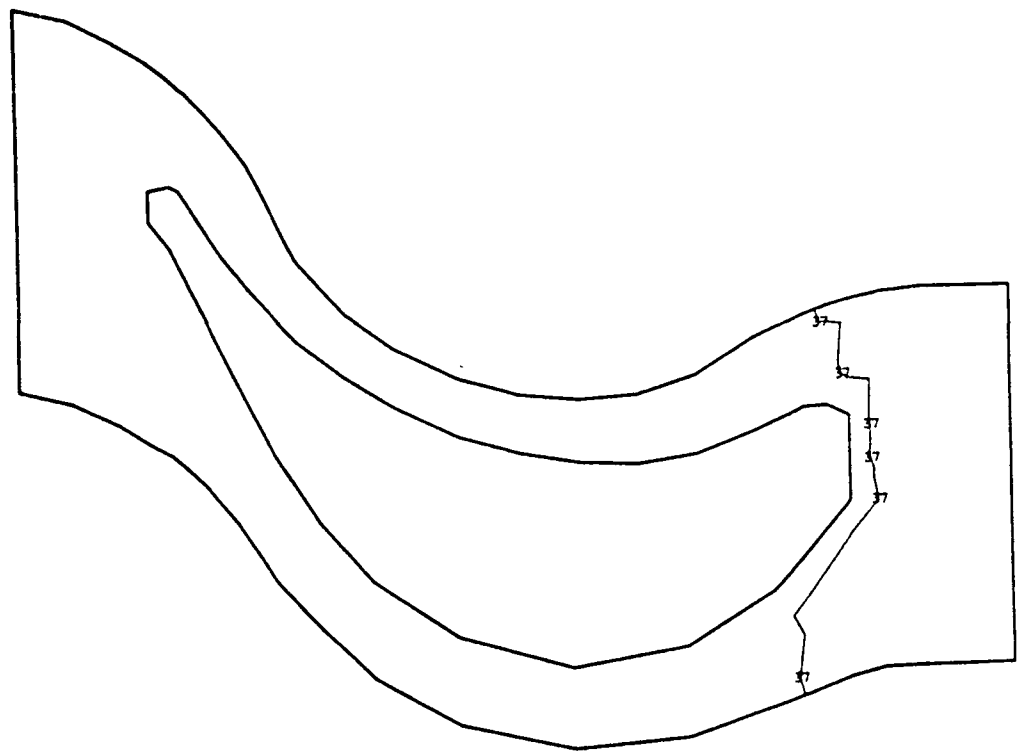

1	-3.000000E 02	14	3.500000E 02	27	1.000000E 03
2	-2.500000E 02	15	4.000000E 02	28	1.050000E 03
3	-2.000000E 02	16	4.500000E 02	29	1.100000E 03
4	-1.500000E 02	17	5.000000E 02	30	1.150000E 03
5	-1.000000E 02	18	5.500000E 02	31	1.200000E 03
6	-5.000000E 01	19	6.000000E 02	32	1.250000E 03
7	0.0	20	6.500000E 02	33	1.300000E 03
8	5.000000E 01	21	7.000000E 02	34	1.350000E 03
9	1.000000E 02	22	7.500000E 02	35	1.400000E 03
10	1.500000E 02	23	8.000000E 02	36	1.450000E 03
11	2.000000E 02	24	8.500000E 02	37	1.500000E 03
12	2.500000E 02	25	9.000000E 02	38	1.550000E 03
13	3.000000E 02	26	9.500000E 02	39	1.600000E 03

Fig. 2.2-6 Model F-1, FPL Load, View 3, Platform Top Steady State Surface Temperatures (F)

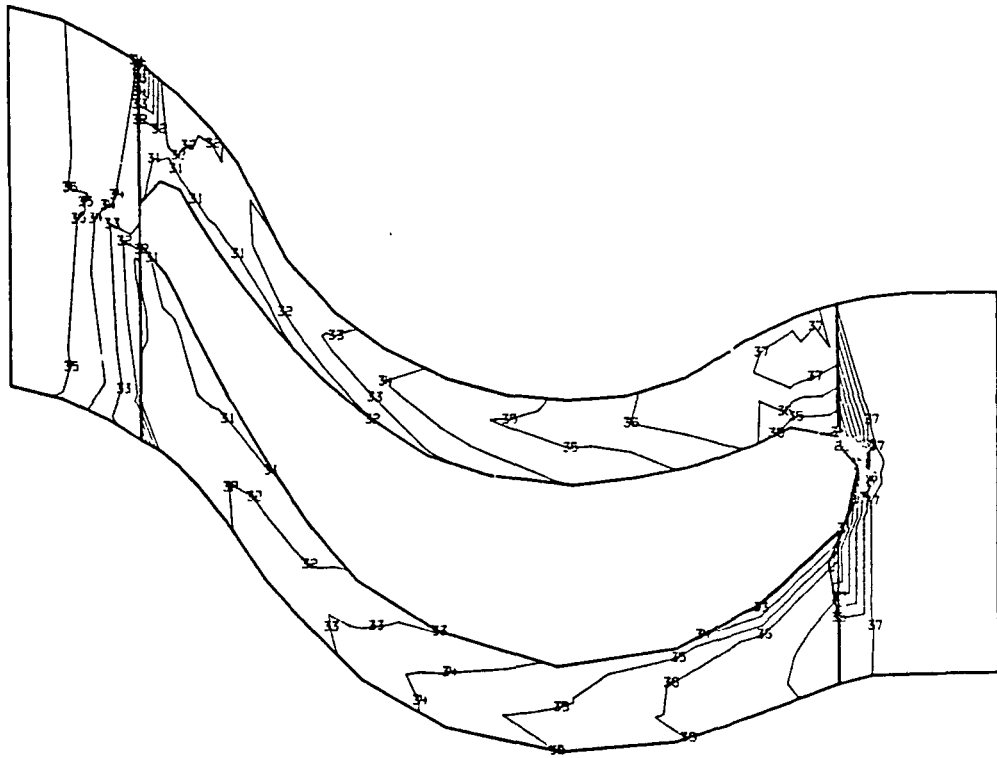

1	-3.000000E 02	14	3.500000E 02	27	1.000000E 03
2	-2.500000E 02	15	4.000000E 02	28	1.050000E 03
3	-2.000000E 02	16	4.500000E 02	29	1.100000E 03
4	-1.500000E 02	17	5.000000E 02	30	1.150000E 03
5	-1.000000E 02	18	5.500000E 02	31	1.200000E 03
6	-5.000000E 01	19	6.000000E 02	32	1.250000E 03
7	0.0	20	6.500000E 02	33	1.300000E 03
8	5.000000E 01	21	7.000000E 02	34	1.350000E 03
9	1.000000E 02	22	7.500000E 02	35	1.400000E 03
10	1.500000E 02	23	8.000000E 02	36	1.450000E 03
11	2.000000E 02	24	8.500000E 02	37	1.500000E 03
12	2.500000E 02	25	9.000000E 02	38	1.550000E 03
13	3.000000E 02	26	9.500000E 02	39	1.600000E 03

Fig. 2.2-7 Model F-1, FPL Load, View 3, Platform Bottom Steady State Surface Temperatures (F)

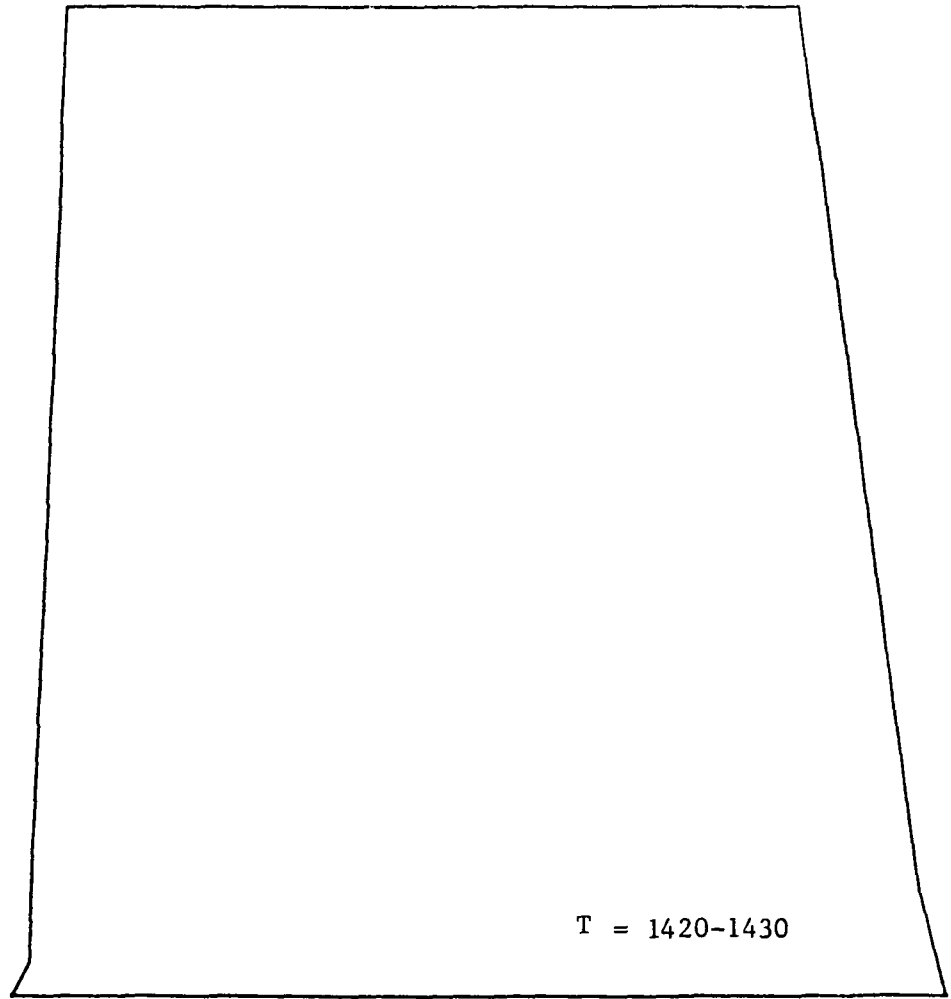

1	-3.000000E 02	14	3.500000E 02	27	1.000000E 03
2	-2.500000E 02	15	4.000000E 02	28	1.050000E 03
3	-2.000000E 02	16	4.500000E 02	29	1.100000E 03
4	-1.500000E 02	17	5.000000E 02	30	1.150000E 03
5	-1.000000E 02	18	5.500000E 02	31	1.200000E 03
6	-5.000000E 01	19	6.000000E 02	32	1.250000E 03
7	0.0	20	6.500000E 02	33	1.300000E 03
8	5.000000E 01	21	7.000000E 02	34	1.350000E 03
9	1.000000E 02	22	7.500000E 02	35	1.400000E 03
10	1.500000E 02	23	8.000000E 02	36	1.450000E 03
11	2.000000E 02	24	8.500000E 02	37	1.500000E 03
12	2.500000E 02	25	9.000000E 02	38	1.550000E 03
13	3.000000E 02	26	9.500000E 02	39	1.600000E 03

Fig. 2.2-8 Model F-1, 115% Load, View 1, Airfoil Suction Side Steady State Surface Temperatures (F)

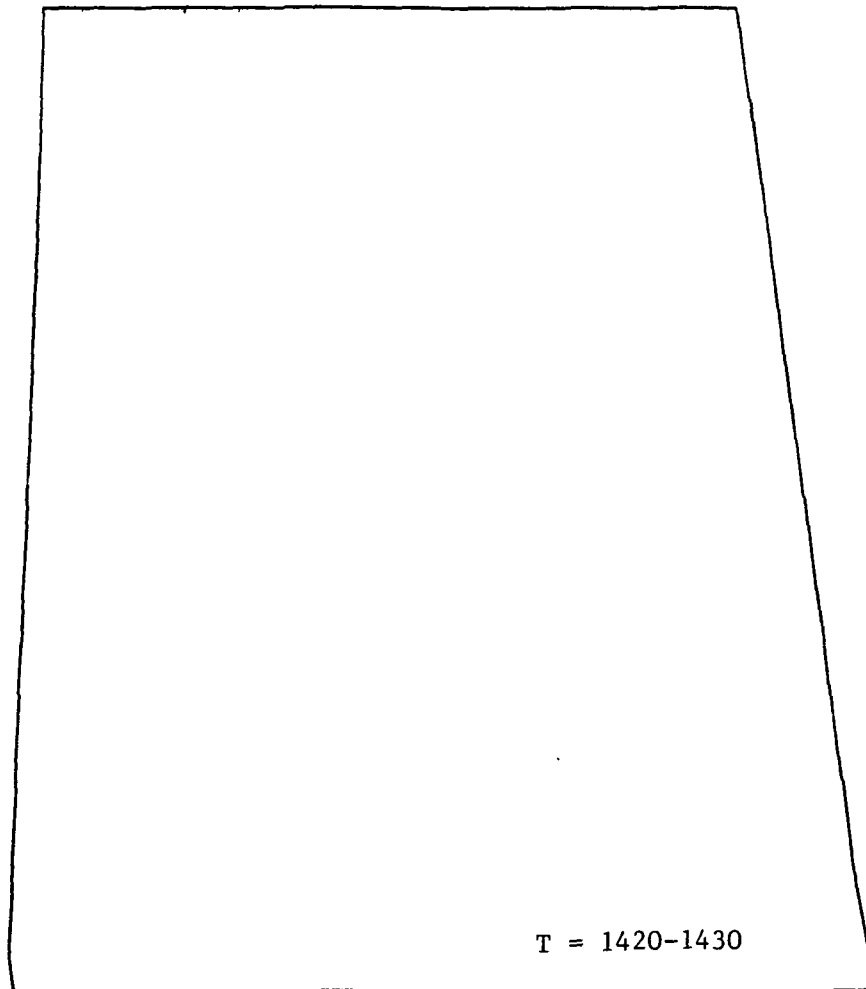

1	-3.000000E 02	14	3.500000E 02	27	1.000000E 03
2	-2.500000E 02	15	4.000000E 02	28	1.050000E 03
3	-2.000000E 02	16	4.500000E 02	29	1.100000E 03
4	-1.500000E 02	17	5.000000E 02	30	1.150000E 03
5	-1.000000E 02	18	5.500000E 02	31	1.200000E 03
6	-5.000000E 01	19	6.000000E 02	32	1.250000E 03
7	0.0	20	6.500000E 02	33	1.300000E 03
8	5.000000E 01	21	7.000000E 02	34	1.350000E 03
9	1.000000E 02	22	7.500000E 02	35	1.400000E 03
10	1.500000E 02	23	8.000000E 02	36	1.450000E 03
11	2.000000E 02	24	8.500000E 02	37	1.500000E 03
12	2.500000E 02	25	9.000000E 02	38	1.550000E 03
13	3.000000E 02	26	9.500000E 02	39	1.600000E 03

Fig. 2.2-9 - Model F-1, 115% Load, View 1, Airfoil Pressure Side
Steady State Surface Temperatures (F)

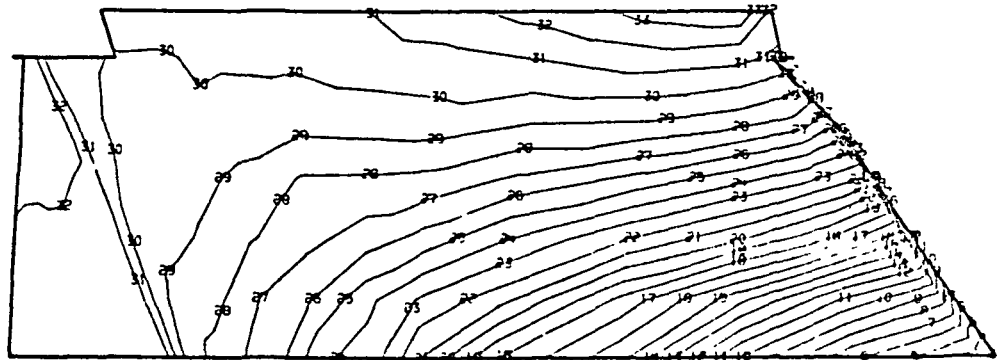

1	-3.000000E 02	14	3.500000E 02	27	1.000000E 03
2	-2.500000E 02	15	4.000000E 02	28	1.050000E 03
3	-2.000000E 02	16	4.500000E 02	29	1.100000E 03
4	-1.500000E 02	17	5.000000E 02	30	1.150000E 03
5	-1.000000E 02	18	5.500000E 02	31	1.200000E 03
6	-5.000000E 01	19	6.000000E 02	32	1.250000E 03
7	0.0	20	6.500000E 02	33	1.300000E 03
8	5.000000E 01	21	7.000000E 02	34	1.350000E 03
9	1.000000E 02	22	7.500000E 02	35	1.400000E 03
10	1.500000E 02	23	8.000000E 02	36	1.450000E 03
11	2.000000E 02	24	8.500000E 02	37	1.500000E 03
12	2.500000E 02	25	9.000000E 02	38	1.550000E 03
13	3.000000E 02	26	9.500000E 02	39	1.600000E 03

Fig. 2.2-10 - Model F-1, 115% Load, View 2, Shank Suction Side
Steady State Surface Temperature (F)

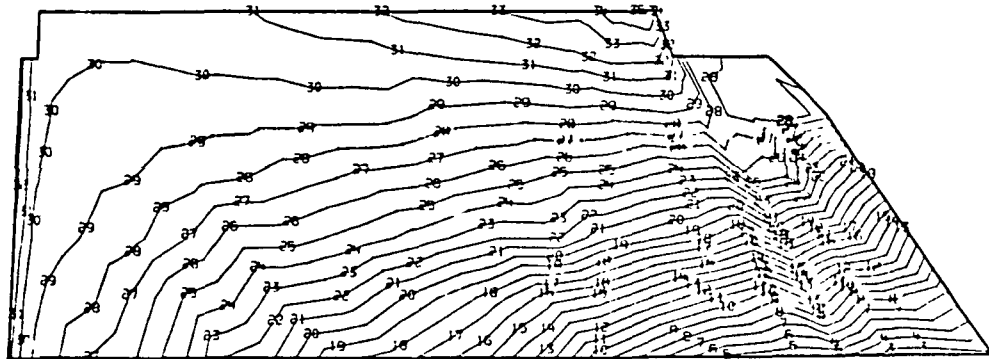

1	-3.000000E 02	14	3.500000E 02	27	1.000000E 03
2	-2.500000E 02	15	4.000000E 02	28	1.050000E 03
3	-2.000000E 02	16	4.500000E 02	29	1.100000E 03
4	-1.500000E 02	17	5.000000E 02	30	1.150000E 03
5	-1.000000E 02	18	5.500000E 02	31	1.200000E 03
6	-5.000000E 01	19	6.000000E 02	32	1.250000E 03
7	0.0	20	6.500000E 02	33	1.300000E 03
8	5.000000E 01	21	7.000000E 02	34	1.350000E 03
9	1.000000E 02	22	7.500000E 02	35	1.400000E 03
10	1.500000E 02	23	8.000000E 02	36	1.450000E 03
11	2.000000E 02	24	8.500000E 02	37	1.500000E 03
12	2.500000E 02	25	9.000000E 02	38	1.550000E 03
13	3.000000E 02	26	9.500000E 02	39	1.600000E 03

Fig. 2.2-11 Model F-1, 115% Load, View 2. Shank Pressure Side Steady State Surface Temperatures (F)

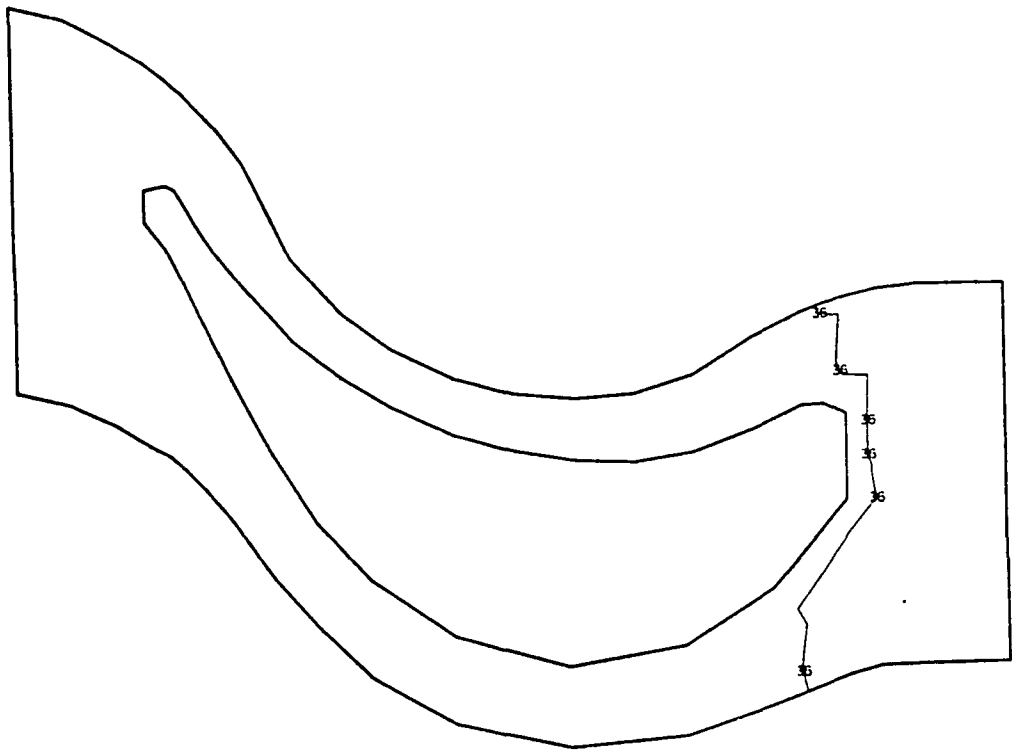

1	-3.000000E 02	14	3.500000E 02	27	1.000000E 03
2	-2.500000E 02	15	4.000000E 02	28	1.050000E 03
3	-2.000000E 02	16	4.500000E 02	29	1.100000E 03
4	-1.500000E 02	17	5.000000E 02	30	1.150000E 03
5	-1.000000E 02	18	5.500000E 02	31	1.200000E 03
6	-5.000000E 01	19	6.000000E 02	32	1.250000E 03
7	0.0	20	6.500000E 02	33	1.300000E 03
8	5.000000E 01	21	7.000000E 02	34	1.350000E 03
9	1.000000E 02	22	7.500000E 02	35	1.400000E 03
10	1.500000E 02	23	8.000000E 02	36	1.450000E 03
11	2.000000E 02	24	8.500000E 02	37	1.500000E 03
12	2.500000E 02	25	9.000000E 02	38	1.550000E 03
13	3.000000E 02	26	9.500000E 02	39	1.600000E 03

Fig. 2.2-12 Model F-1, 115% Load, View 3, Platform Top Steady State Surface Temperatures (F)

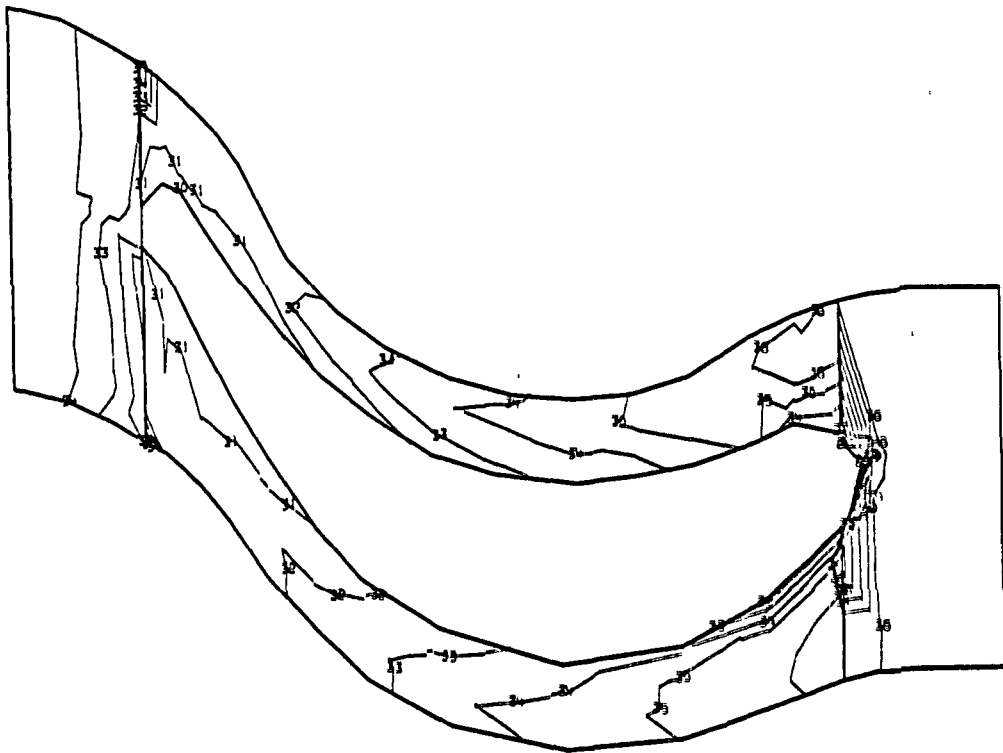

1	-3.000000E 02	14	3.500000E 02	27	1.000000E 03
2	-2.500000E 02	15	4.000000E 02	28	1.050000E 03
3	-2.000000E 02	16	4.500000E 02	29	1.100000E 03
4	-1.500000E 02	17	5.000000E 02	30	1.150000E 03
5	-1.000000E 02	18	5.500000E 02	31	1.200000E 03
6	-5.000000E 01	19	6.000000E 02	32	1.250000E 03
7	0.0	20	6.500000E 02	33	1.300000E 03
8	5.000000E 01	21	7.000000E 02	34	1.350000E 03
9	1.000000E 02	22	7.500000E 02	35	1.400000E 03
10	1.500000E 02	23	8.000000E 02	36	1.450000E 03
11	2.000000E 02	24	8.500000E 02	37	1.500000E 03
12	2.500000E 02	25	9.000000E 02	38	1.550000E 03
13	3.000000E 02	26	9.500000E 02	39	1.600000E 03

Fig. 2.2-13 Model F-1, 115% Load, View 3, Platform Bottom Steady State Surface Temperatures (F)

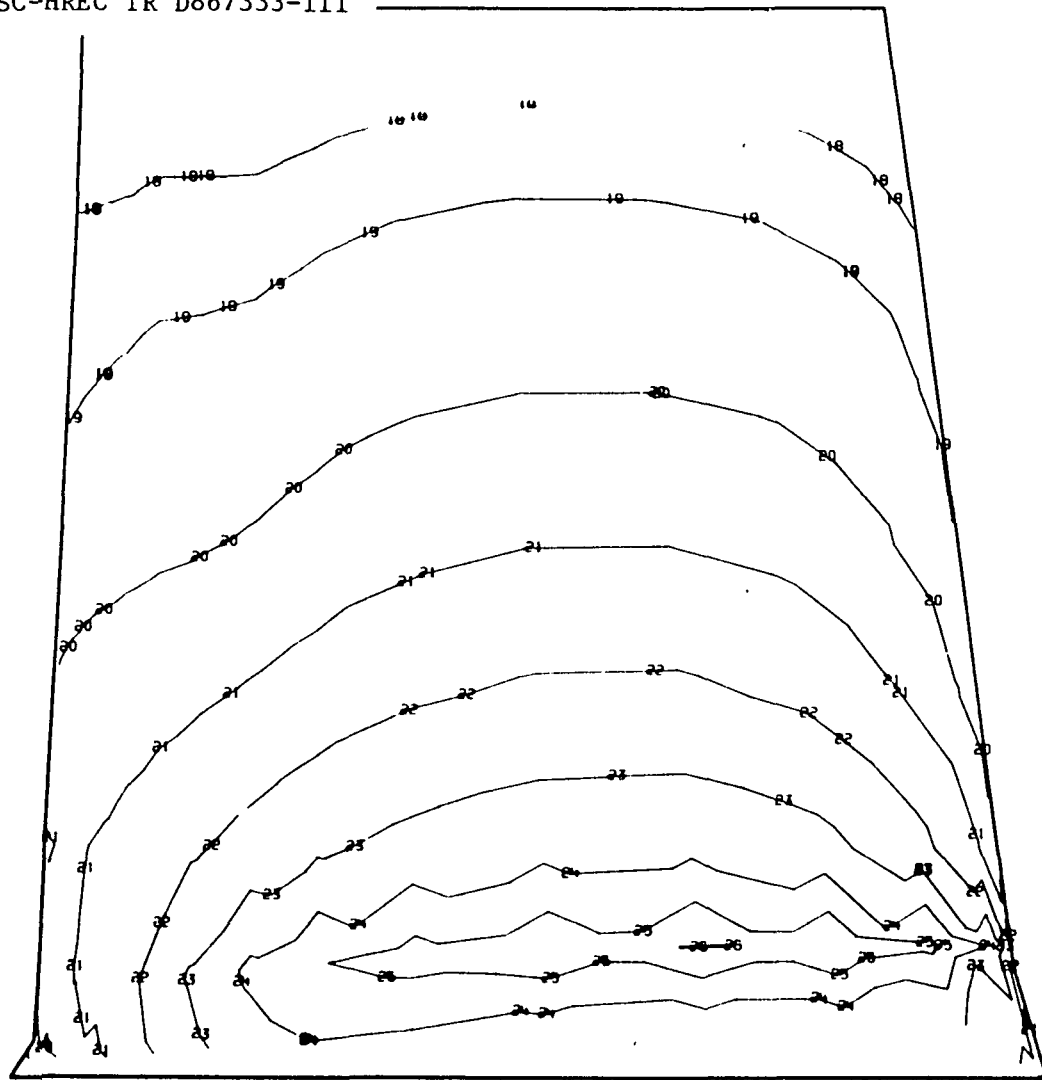

1	-1.500000E 05	12	-4.000000E 04	23	5.000000E 04
2	-1.400000E 05	13	-3.000000E 04	24	6.000000E 04
3	-1.300000E 05	14	-2.000000E 04	25	7.000000E 04
4	-1.200000E 05	15	-1.000000E 04	26	8.000000E 04
5	-1.100000E 05	16	-5.000000E 03	27	9.000000E 04
6	-1.000000E 05	17	0.0	28	1.000000E 05
7	-9.000000E 04	18	5.000000E 03	29	1.100000E 05
8	-8.000000E 04	19	1.000000E 04	30	1.200000E 05
9	-7.000000E 04	20	2.000000E 04	31	1.300000E 05
10	-6.000000E 04	21	3.000000E 04	32	1.400000E 05
11	-5.000000E 04	22	4.000000E 04	33	1.500000E 05

Fig. 2.2-14 Model F-1, FPL Load, View 1, Airfoil Suction Side Major Principal Stress (psi)



1	-1.500000E 05	12	-4.000000E 04	23	5.000000E 04
2	-1.400000E 05	13	-3.000000E 04	24	6.000000E 04
3	-1.300000E 05	14	-2.000000E 04	25	7.000000E 04
4	-1.200000E 05	15	-1.000000E 04	26	8.000000E 04
5	-1.100000E 05	16	-5.000000E 03	27	9.000000E 04
6	-1.000000E 05	17	0.0	28	1.000000E 05
7	-9.000000E 04	18	5.000000E 03	29	1.100000E 05
8	-8.000000E 04	19	1.000000E 04	30	1.200000E 05
9	-7.000000E 04	20	2.000000E 04	31	1.300000E 05
10	-6.000000E 04	21	3.000000E 04	32	1.400000E 05
11	-5.000000E 04	22	4.000000E 04	33	1.500000E 05

Fig. 2.2-15 Model F-1, FPL Load, View 1, Airfoil Suction Side Minor Principal Stress (psi)

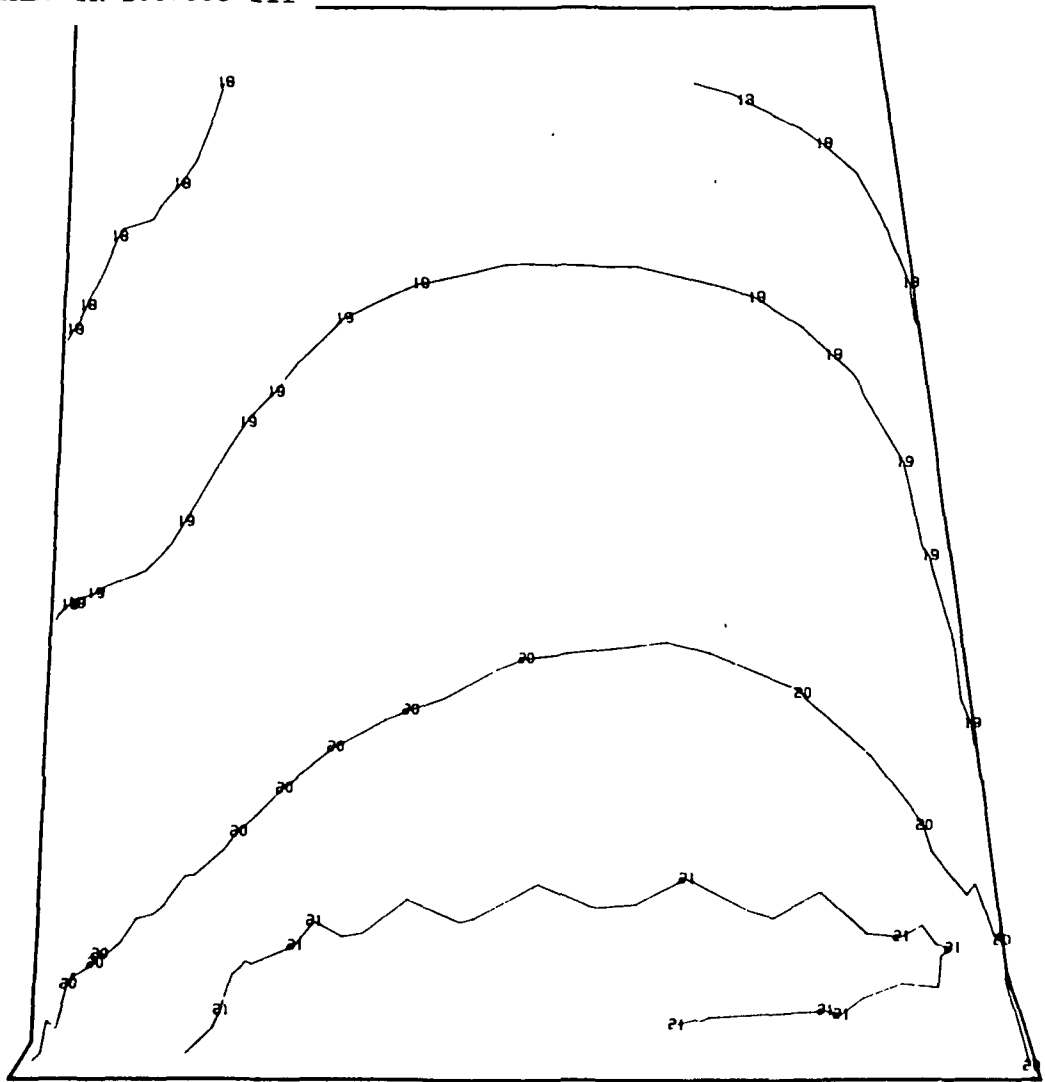

1	-1.500000E 05	12	-4.000000E 04	23	5.000000E 04
2	-1.400000E 05	13	-3.000000E 04	24	6.000000E 04
3	-1.300000E 05	14	-2.000000E 04	25	7.000000E 04
4	-1.200000E 05	15	-1.000000E 04	26	8.000000E 04
5	-1.100000E 05	16	-5.000000E 03	27	9.000000E 04
6	-1.000000E 05	17	0.0	28	1.000000E 05
7	-9.000000E 04	18	5.000000E 03	29	1.100000E 05
8	-8.000000E 04	19	1.000000E 04	30	1.200000E 05
9	-7.000000E 04	20	2.000000E 04	31	1.300000E 05
10	-6.000000E 04	21	3.000000E 04	32	1.400000E 05
11	-5.000000E 04	22	4.000000E 04	33	1.500000E 05

Fig. 2.2-16 Model F-1, FPL Load, View 1, Airfoil Suction Side Maximum Principal Shear (psi)

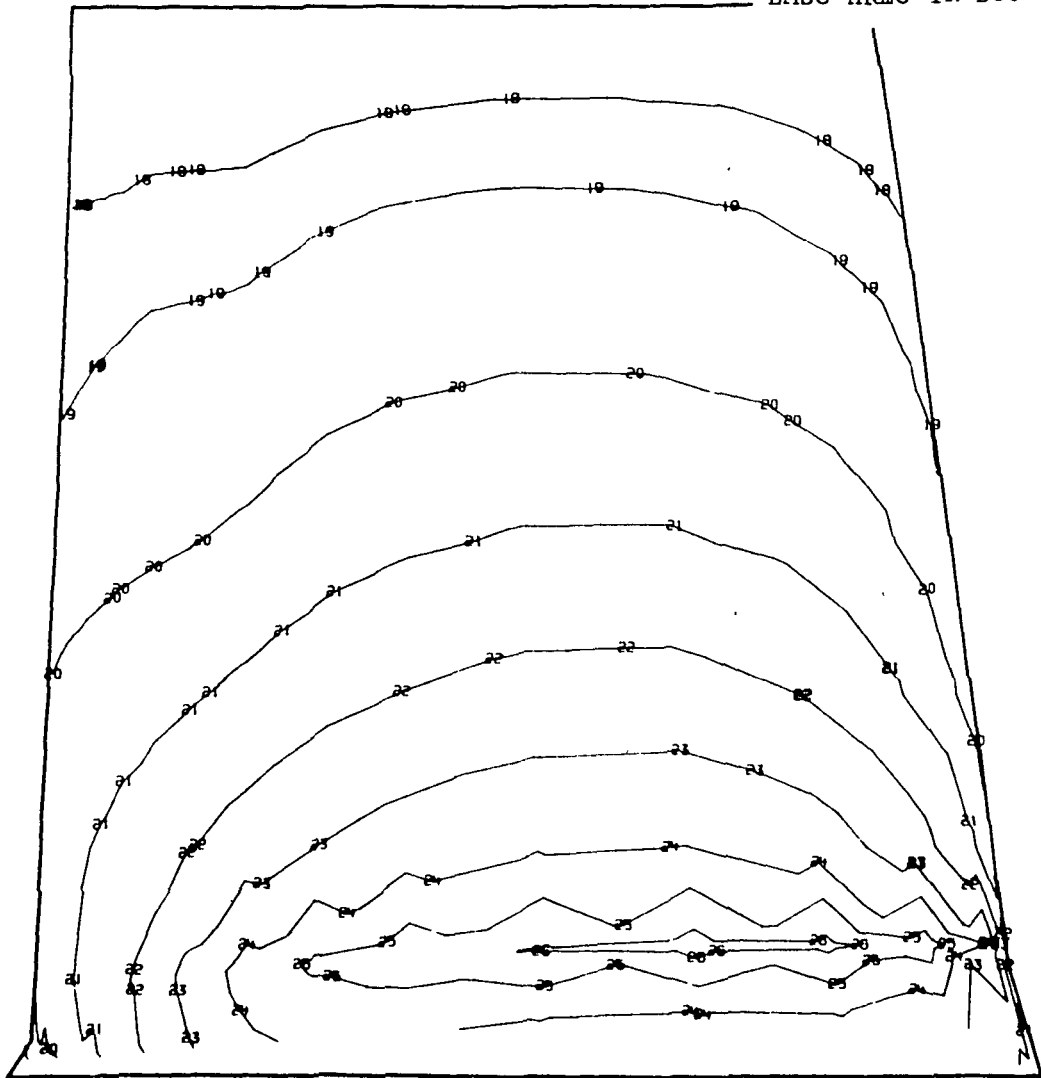

1	-1.500000E 05	12	-4.000000E 04	23	5.000000E 04
2	-1.400000E 05	13	-3.000000E 04	24	6.000000E 04
3	-1.300000E 05	14	-2.000000E 04	25	7.000000E 04
4	-1.200000E 05	15	-1.000000E 04	26	8.000000E 04
5	-1.100000E 05	16	-5.000000E 03	27	9.000000E 04
6	-1.000000E 05	17	0.0	28	1.000000E 05
7	-9.000000E 04	18	5.000000E 03	29	1.100000E 05
8	-8.000000E 04	19	1.000000E 04	30	1.200000E 05
9	-7.000000E 04	20	2.000000E 04	31	1.300000E 05
10	-6.000000E 04	21	3.000000E 04	32	1.400000E 05
11	-5.000000E 04	22	4.000000E 04	33	1.500000E 05

Fig. 2.2-17 Model F-1, 115% Load, View 1, Airfoil Suction Side Major Principal Stress (psi)

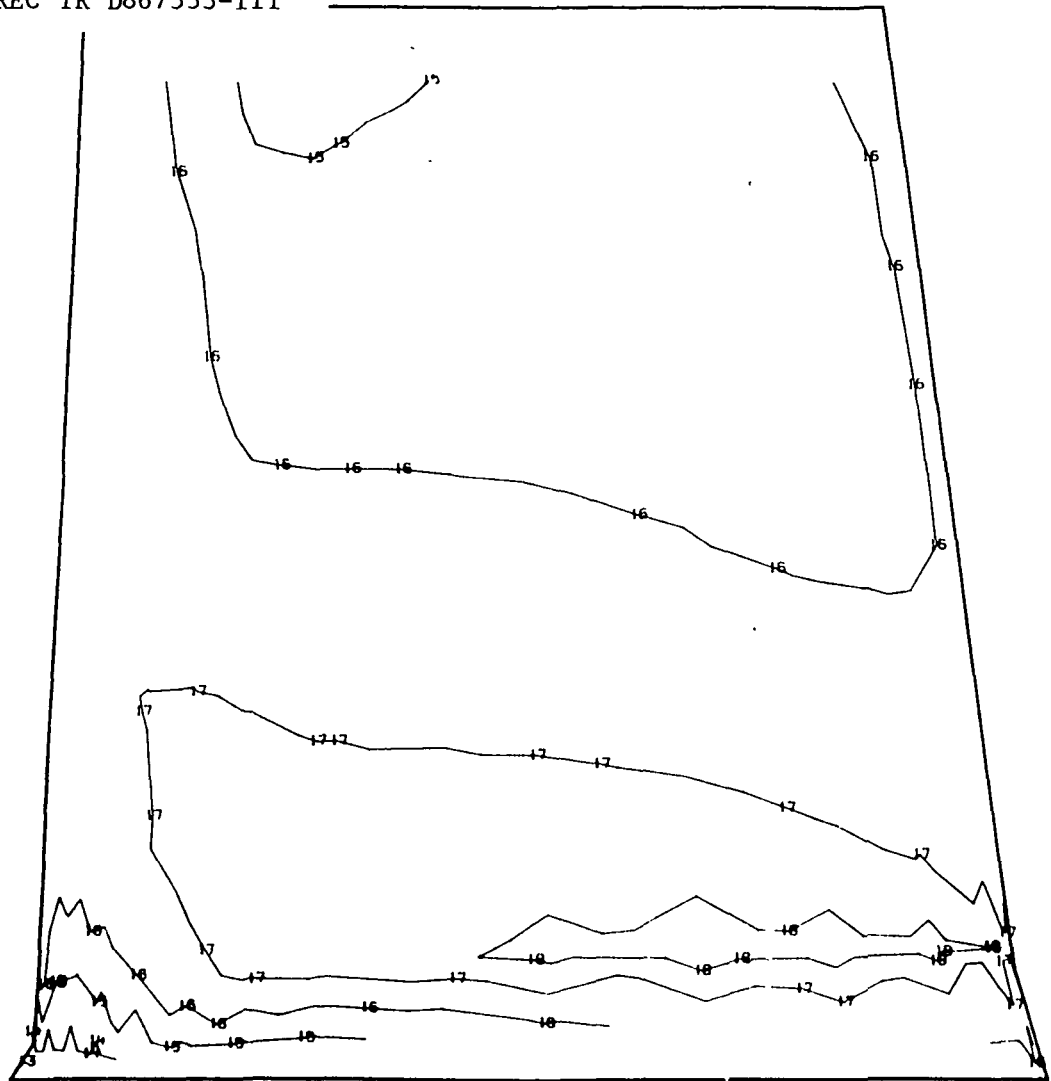

1	-1.500000E 05	12	-4.000000E 04	23	5.000000E 04
2	-1.400000E 05	13	-3.000000E 04	24	6.000000E 04
3	-1.300000E 05	14	-2.000000E 04	25	7.000000E 04
4	-1.200000E 05	15	-1.000000E 04	26	8.000000E 04
5	-1.100000E 05	16	-5.000000E 03	27	9.000000E 04
6	-1.000000E 05	17	0.0	28	1.000000E 05
7	-9.000000E 04	18	5.000000E 03	29	1.100000E 05
8	-8.000000E 04	19	1.000000E 04	30	1.200000E 05
9	-7.000000E 04	20	2.000000E 04	31	1.300000E 05
10	-6.000000E 04	21	3.000000E 04	32	1.400000E 05
11	-5.000000E 04	22	4.000000E 04	33	1.500000E 05

Fig. 2.2-18 Model F-1, 115% Load, View 1, Airfoil Suction Side Minor Principal Stress (psi)

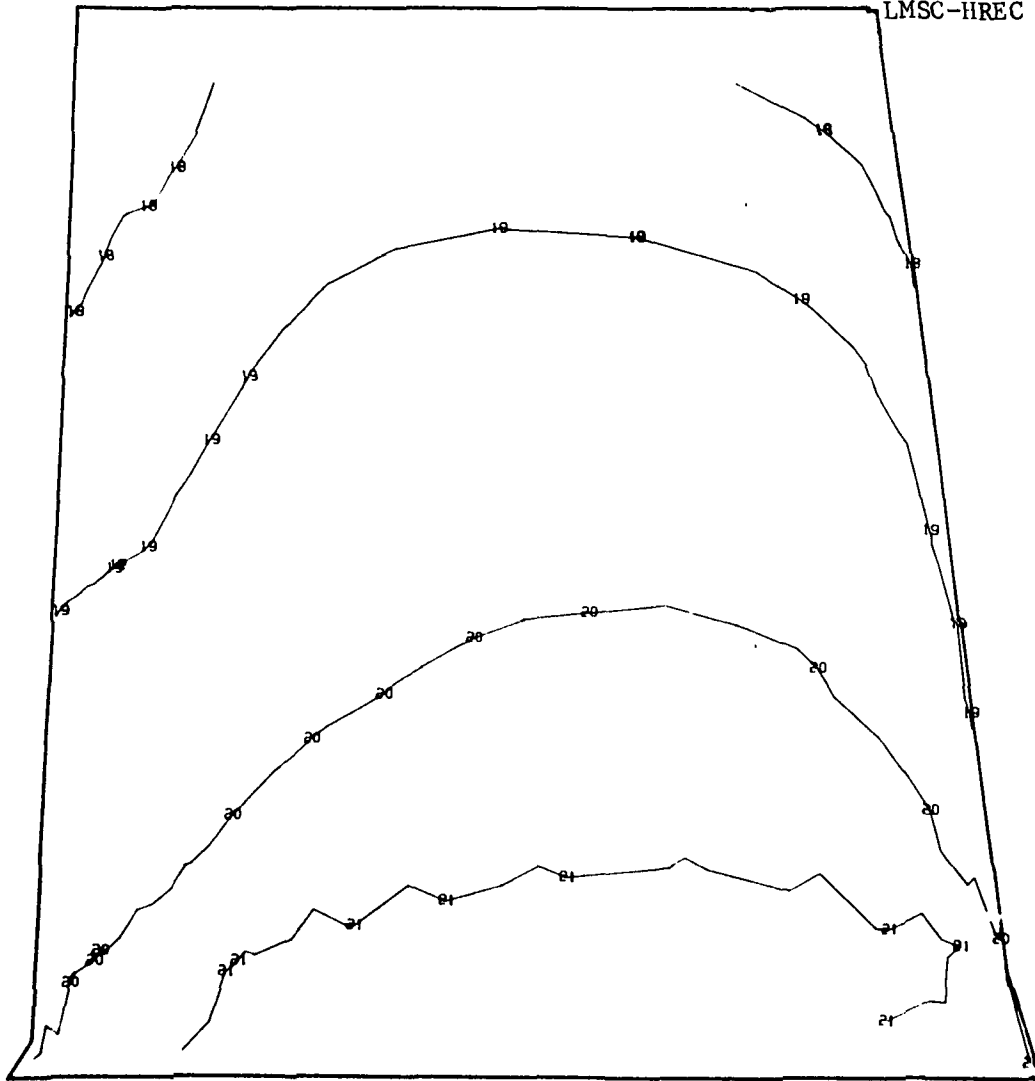

1	-1.500000E 05	12	-4.000000E 04	23	5.000000E 04
2	-1.400000E 05	13	-3.000000E 04	24	6.000000E 04
3	-1.300000E 05	14	-2.000000E 04	25	7.000000E 04
4	-1.200000E 05	15	-1.000000E 04	26	8.000000E 04
5	-1.100000E 05	16	-5.000000E 03	27	9.000000E 04
6	-1.000000E 05	17	0.0	28	1.000000E 05
7	-9.000000E 04	18	5.000000E 03	29	1.100000E 05
8	-8.000000E 04	19	1.000000E 04	30	1.200000E 05
9	-7.000000E 04	20	2.000000E 04	31	1.300000E 05
10	-6.000000E 04	21	3.000000E 04	32	1.400000E 05
11	-5.000000E 04	22	4.000000E 04	33	1.500000E 05

Fig. 2.2-19 Model F-1, 115% Load, View 1, Airfoil Suction Side
Maximum Principal Shear (psi)

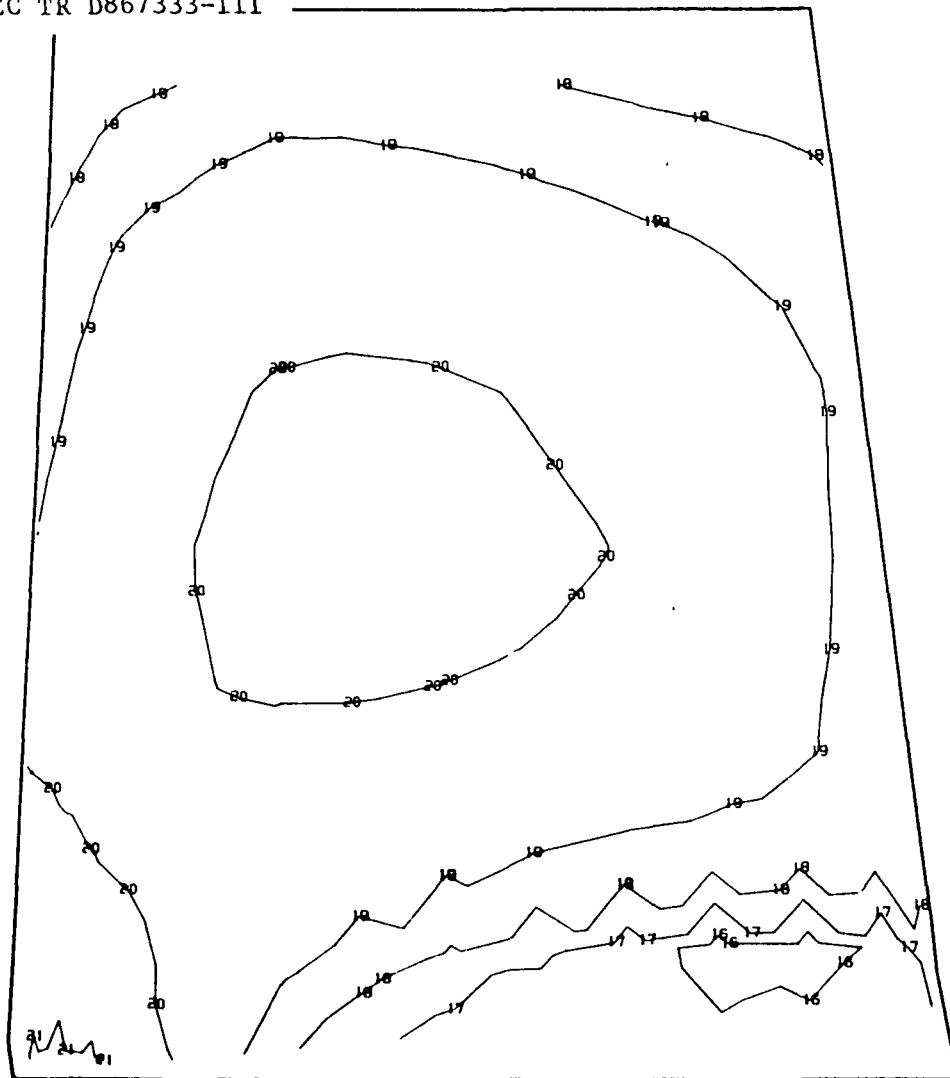

1	-1.500000E	05	12	-4.000000E	04	23	5.000000E	04
2	-1.400000E	05	13	-3.000000E	04	24	6.000000E	04
3	-1.300000E	05	14	-2.000000E	04	25	7.000000E	04
4	-1.200000E	05	15	-1.000000E	04	26	8.000000E	04
5	-1.100000E	05	16	-5.000000E	03	27	9.000000E	04
6	-1.000000E	05	17	0.0		28	1.000000E	05
7	-9.000000E	04	18	5.000000E	03	29	1.100000E	05
8	-8.000000E	04	19	1.000000E	04	30	1.200000E	05
9	-7.000000E	04	20	2.000000E	04	31	1.300000E	05
10	-6.000000E	04	21	3.000000E	04	32	1.400000E	05
11	-5.000000E	04	22	4.000000E	04	33	1.500000E	05

Fig. 2.2-20 Model F-1, FPL Load, View 1, Airfoil Pressure Side Major Principal Stress (psi)



1	-1.500000E 05	12	-4.000000E 04	23	5.000000E 04
2	-1.400000E 05	13	-3.000000E 04	24	6.000000E 04
3	-1.300000E 05	14	-2.000000E 04	25	7.000000E 04
4	-1.200000E 05	15	-1.000000E 04	26	8.000000E 04
5	-1.100000E 05	16	-5.000000E 03	27	9.000000E 04
6	-1.000000E 05	17	0.0	28	1.000000E 05
7	-9.000000E 04	18	5.000000E 03	29	1.100000E 05
8	-8.000000E 04	19	1.000000E 04	30	1.200000E 05
9	-7.000000E 04	20	2.000000E 04	31	1.300000E 05
10	-6.000000E 04	21	3.000000E 04	32	1.400000E 05
11	-5.000000E 04	22	4.000000E 04	33	1.500000E 05

Fig. 2.2-21 Model F-1, FPL Load, View 1, Airfoil Pressure Side
Minor Principal Stress (psi)

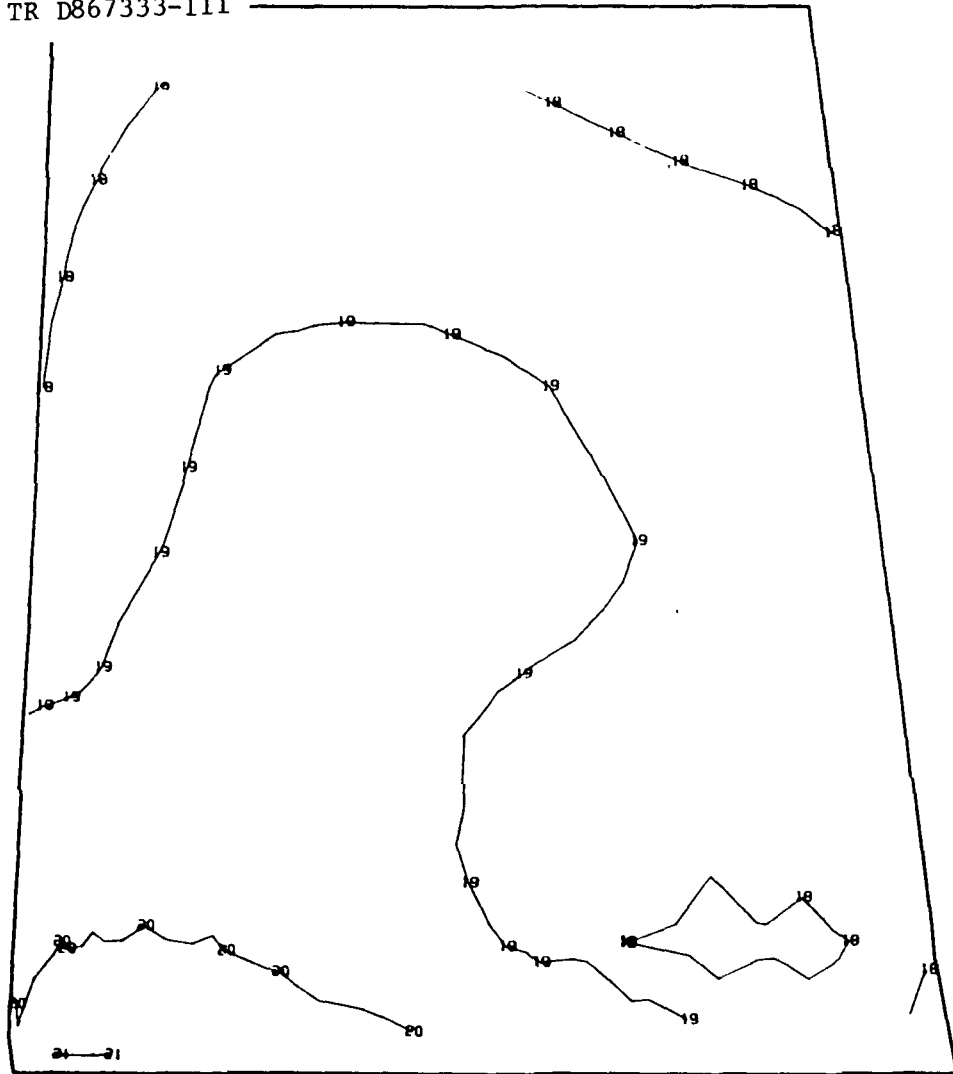

1	-1.500000E 05	05	12	-4.000000E 04	04	23	5.000000E 04	04
2	-1.400000E 05	05	13	-3.000000E 04	04	24	6.000000E 04	04
3	-1.300000E 05	05	14	-2.000000E 04	04	25	7.000000E 04	04
4	-1.200000E 05	05	15	-1.000000E 04	04	26	8.000000E 04	04
5	-1.100000E 05	05	16	-5.000000E 03	03	27	9.000000E 04	04
6	-1.000000E 05	05	17	0.0		28	1.000000E 05	05
7	-9.000000E 04	04	18	5.000000E 03	03	29	1.100000E 05	05
8	-8.000000E 04	04	19	1.000000E 04	04	30	1.200000E 05	05
9	-7.000000E 04	04	20	2.000000E 04	04	31	1.300000E 05	05
10	-6.000000E 04	04	21	3.000000E 04	04	32	1.400000E 05	05
11	-5.000000E 04	04	22	4.000000E 04	04	33	1.500000E 05	05

Fig. 2.2-22 Model F-1, FPL Load, View 1, Airfoil Pressure Side
Maximum Principal Shear (psi)

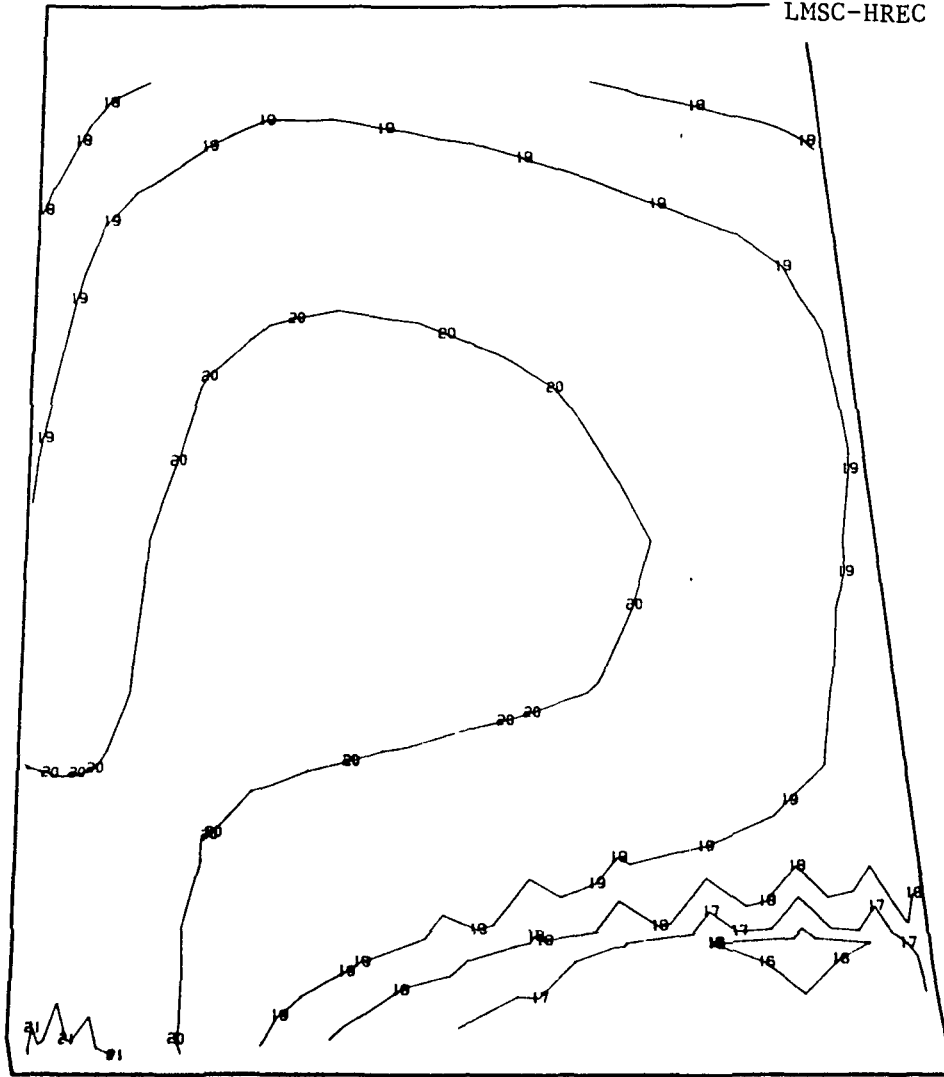

1	-1.500000E 05	12	-4.000000E 04	23	5.000000E 04
2	-1.400000E 05	13	-3.000000E 04	24	6.000000E 04
3	-1.300000E 05	14	-2.000000E 04	25	7.000000E 04
4	-1.200000E 05	15	-1.000000E 04	26	8.000000E 04
5	-1.100000E 05	16	-5.000000E 03	27	9.000000E 04
6	-1.000000E 05	17	0.0	28	1.000000E 05
7	-9.000000E 04	18	5.000000E 03	29	1.100000E 05
8	-8.000000E 04	19	1.000000E 04	30	1.200000E 05
9	-7.000000E 04	20	2.000000E 04	31	1.300000E 05
10	-6.000000E 04	21	3.000000E 04	32	1.400000E 05
11	-5.000000E 04	22	4.000000E 04	33	1.500000E 05

Fig. 2.2-23 Model F-1, 115% Load, View 1, Airfoil Pressure Side Major Principal Stress (psi)

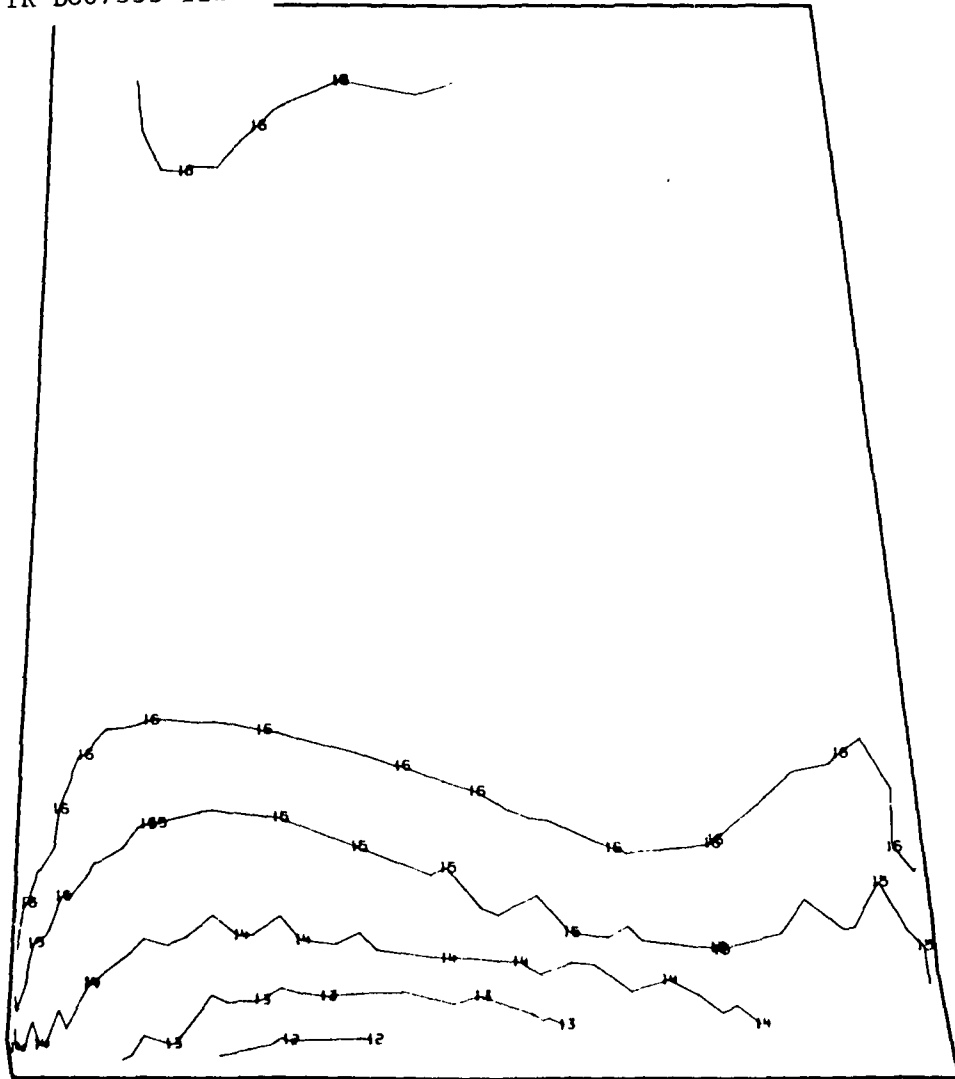

1	-1.500000E 05	05	12	-4.000000E 04	04	23	5.000000E 04	04
2	-1.400000E 05	05	13	-3.000000E 04	04	24	6.000000E 04	04
3	-1.300000E 05	05	14	-2.000000E 04	04	25	7.000000E 04	04
4	-1.200000E 05	05	15	-1.000000E 04	04	26	8.000000E 04	04
5	-1.100000E 05	05	16	-5.000000E 03	03	27	9.000000E 04	04
6	-1.000000E 05	05	17	0.0		28	1.000000E 05	05
7	-9.000000E 04	04	18	5.000000E 03	03	29	1.100000E 05	05
8	-8.000000E 04	04	19	1.000000E 04	04	30	1.200000E 05	05
9	-7.000000E 04	04	20	2.000000E 04	04	31	1.300000E 05	05
10	-6.000000E 04	04	21	3.000000E 04	04	32	1.400000E 05	05
11	-5.000000E 04	04	22	4.000000E 04	04	33	1.500000E 05	05

Fig. 2.2-24 Model F-1, 115% Load, View 1, Airfoil Pressure Side
Minor Principal Stress (psi)

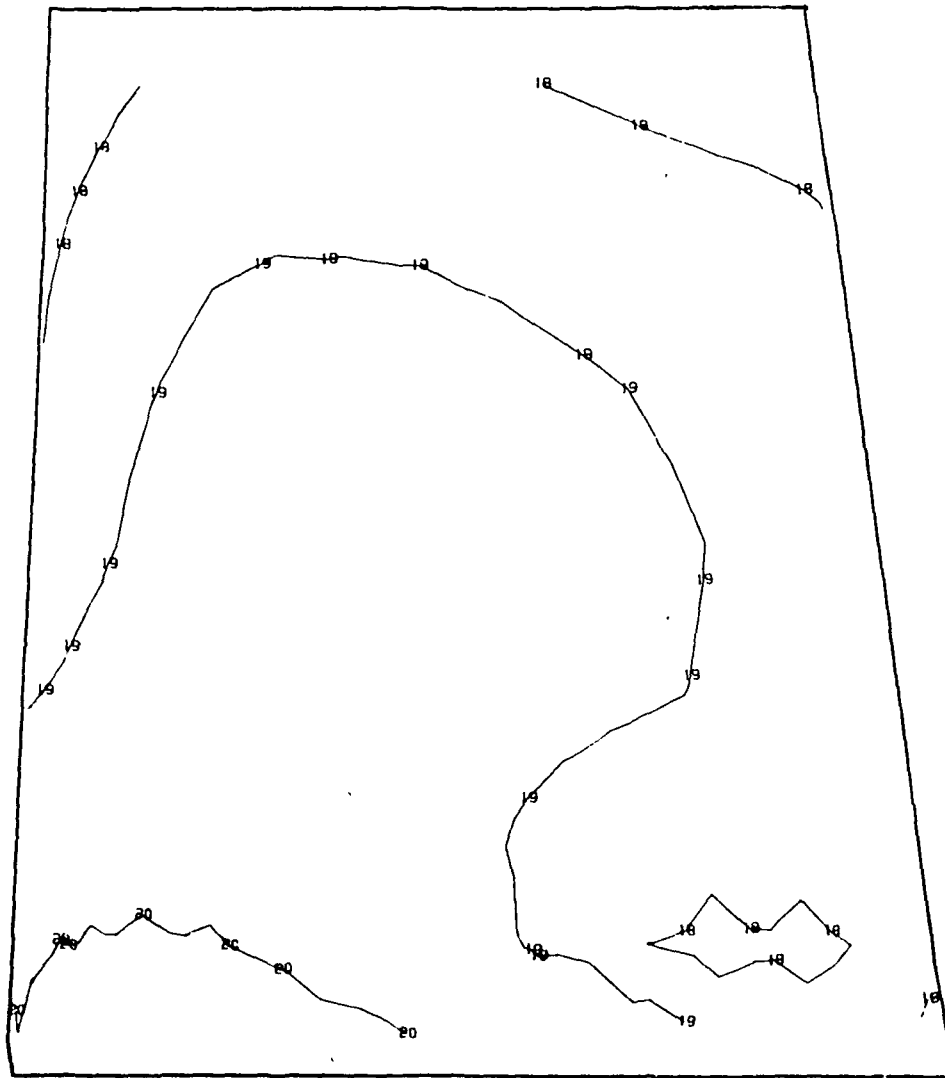

1	-1.500000E 05	12	-4.000000E 04	23	5.000000E 04
2	-1.400000E 05	13	-3.000000E 04	24	6.000000E 04
3	-1.300000E 05	14	-2.000000E 04	25	7.000000E 04
4	-1.200000E 05	15	-1.000000E 04	26	8.000000E 04
5	-1.100000E 05	16	-5.000000E 03	27	9.000000E 04
6	-1.000000E 05	17	0.0	28	1.000000E 05
7	-9.000000E 04	18	5.000000E 03	29	1.100000E 05
8	-8.000000E 04	19	1.000000E 04	30	1.200000E 05
9	-7.000000E 04	20	2.000000E 04	31	1.300000E 05
10	-6.000000E 04	21	3.000000E 04	32	1.400000E 05
11	-5.000000E 04	22	4.000000E 04	33	1.500000E 05

Fig. 2.2-25 Model F-1, 115% Load, View 1, Airfoil Pressure Side
Maximum Principal Shear (psi)

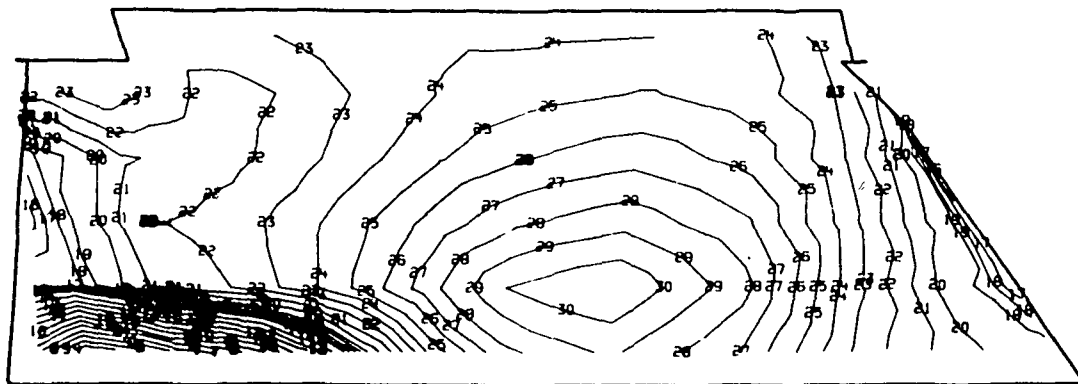

1	-1.500000E 05	12	-4.000000E 04	23	5.000000E 04
2	-1.400000E 05	13	-3.000000E 04	24	6.000000E 04
3	-1.300000E 05	14	-2.000000E 04	25	7.000000E 04
4	-1.200000E 05	15	-1.000000E 04	26	8.000000E 04
5	-1.100000E 05	16	-5.000000E 03	27	9.000000E 04
6	-1.000000E 05	17	0.0	28	1.000000E 05
7	-9.000000E 04	18	5.000000E 03	29	1.100000E 05
8	-8.000000E 04	19	1.000000E 04	30	1.200000E 05
9	-7.000000E 04	20	2.000000E 04	31	1.300000E 05
10	-6.000000E 04	21	3.000000E 04	32	1.400000E 05
11	-5.000000E 04	22	4.000000E 04	33	1.500000E 05

Fig. 2.2-26 Model F-1, FPL Load, View 2, Shank Suction Side Major Principal Stress (psi)

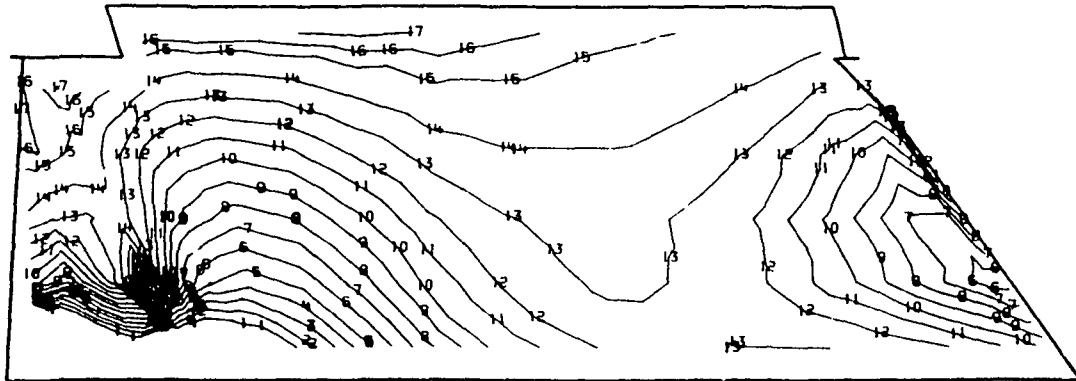

1	-1.500000E 05	12	-4.000000E 04	23	5.000000E 04
2	-1.400000E 05	13	-3.000000E 04	24	6.000000E 04
3	-1.300000E 05	14	-2.000000E 04	25	7.000000E 04
4	-1.200000E 05	15	-1.000000E 04	26	8.000000E 04
5	-1.100000E 05	16	-5.000000E 03	27	9.000000E 04
6	-1.000000E 05	17	0.0	28	1.000000E 05
7	-9.000000E 04	18	5.000000E 03	29	1.100000E 05
8	-8.000000E 04	19	1.000000E 04	30	1.200000E 05
9	-7.000000E 04	20	2.000000E 04	31	1.300000E 05
10	-6.000000E 04	21	3.000000E 04	32	1.400000E 05
11	-5.000000E 04	22	4.000000E 04	33	1.500000E 05

Fig. 2.2-27 Model F-1, FPL Load, View 2, Shank Suction Side Minor Principal Stress, (psi)

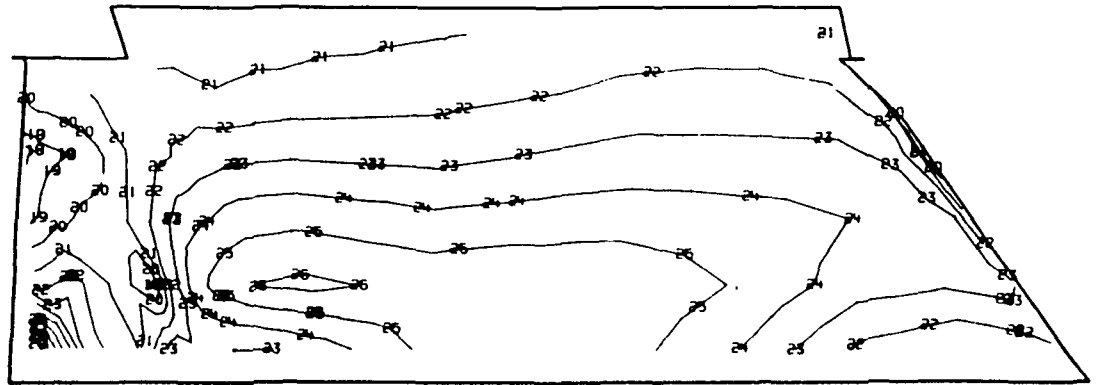

1	-1.500000E	05	12	-4.000000E	04	23	5.000000E	04
2	-1.400000E	05	13	-3.000000E	04	24	6.000000E	04
3	-1.300000E	05	14	-2.000000E	04	25	7.000000E	04
4	-1.200000E	05	15	-1.000000E	04	26	8.000000E	04
5	-1.100000E	05	16	-5.000000E	03	27	9.000000E	04
6	-1.000000E	05	17	0.0		28	1.000000E	05
7	-9.000000E	04	18	5.000000E	03	29	1.100000E	05
8	-8.000000E	04	19	1.000000E	04	30	1.200000E	05
9	-7.000000E	04	20	2.000000E	04	31	1.300000E	05
10	-6.000000E	04	21	3.000000E	04	32	1.400000E	05
11	-5.000000E	04	22	4.000000E	04	33	1.500000E	05

Fig. 2.2-28 Model F-1, FPL Load, View 2, Shank Suction Side Maximum Principal Shear (psi)

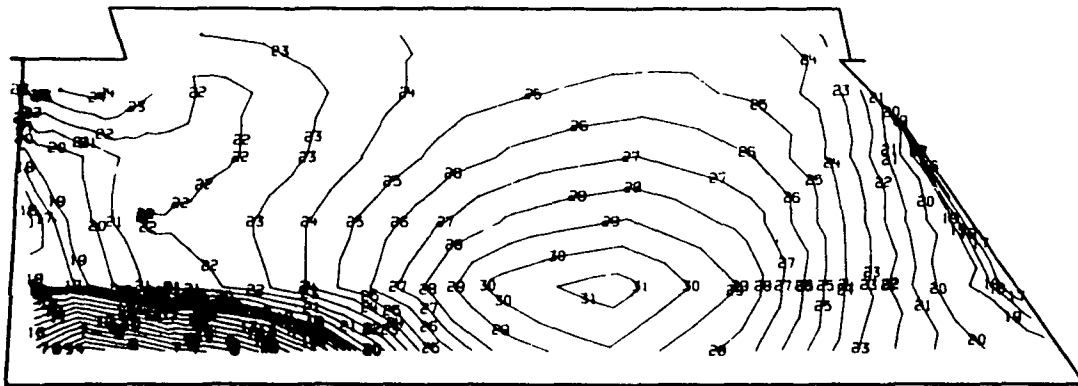

1	-1.500000E 05	12	-4.000000E 04	23	5.000000E 04
2	-1.400000E 05	13	-3.000000E 04	24	6.000000E 04
3	-1.300000E 05	14	-2.000000E 04	25	7.000000E 04
4	-1.200000E 05	15	-1.000000E 04	26	8.000000E 04
5	-1.100000E 05	16	-5.000000E 03	27	9.000000E 04
6	-1.000000E 05	17	0.0	28	1.000000E 05
7	-9.000000E 04	18	5.000000E 03	29	1.100000E 05
8	-8.000000E 04	19	1.000000E 04	30	1.200000E 05
9	-7.000000E 04	20	2.000000E 04	31	1.300000E 05
10	-6.000000E 04	21	3.000000E 04	32	1.400000E 05
11	-5.000000E 04	22	4.000000E 04	33	1.500000E 05

Fig. 2.2-29 Model F-1, 115% Load, View 2, Shank Suction Side
Major Principal Stress (psi)

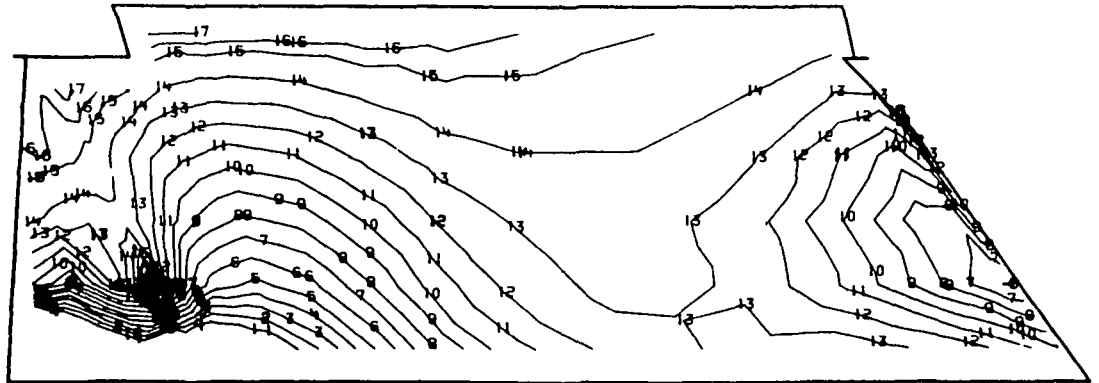

1	-1.500000E 05	12	-4.000000E 04	23	5.000000E 04
2	-1.400000E 05	13	-3.000000E 04	24	6.000000E 04
3	-1.300000E 05	14	-2.000000E 04	25	7.000000E 04
4	-1.200000E 05	15	-1.000000E 04	26	8.000000E 04
5	-1.100000E 05	16	-5.000000E 03	27	9.000000E 04
6	-1.000000E 05	17	0.0	28	1.000000E 05
7	-9.000000E 04	18	5.000000E 03	29	1.100000E 05
8	-8.000000E 04	19	1.000000E 04	30	1.200000E 05
9	-7.000000E 04	20	2.000000E 04	31	1.300000E 05
10	-6.000000E 04	21	3.000000E 04	32	1.400000E 05
11	-5.000000E 04	22	4.000000E 04	33	1.500000E 05

Fig. 2.2-30 Model F-1, 115% Load, View 2, Shank Suction Side
Minor Principal Stress (psi)

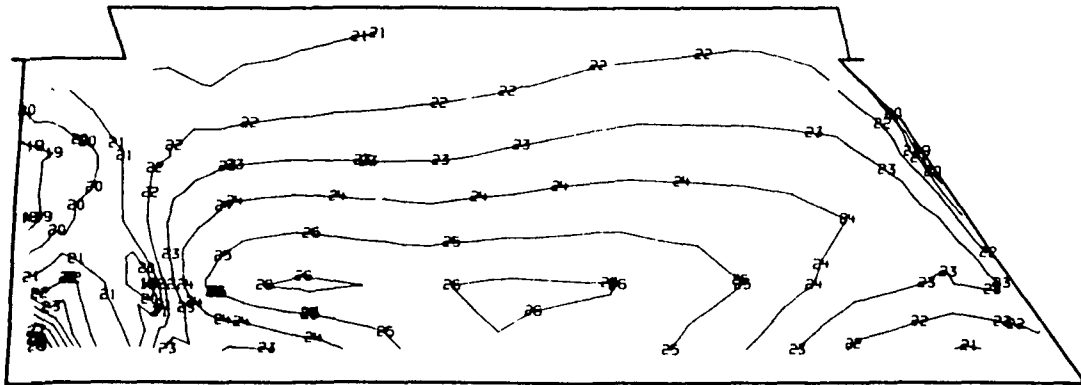

1	-1.500000E 05	12	-4.000000E 04	23	5.000000E 04
2	-1.400000E 05	13	-3.000000E 04	24	6.000000E 04
3	-1.300000E 05	14	-2.000000E 04	25	7.000000E 04
4	-1.200000E 05	15	-1.000000E 04	26	8.000000E 04
5	-1.100000E 05	16	-5.000000E 03	27	9.000000E 04
6	-1.000000E 05	17	0.0	28	1.000000E 05
7	-9.000000E 04	18	5.000000E 03	29	1.100000E 05
8	-8.000000E 04	19	1.000000E 04	30	1.200000E 05
9	-7.000000E 04	20	2.000000E 04	31	1.300000E 05
10	-6.000000E 04	21	3.000000E 04	32	1.400000E 05
11	-5.000000E 04	22	4.000000E 04	33	1.500000E 05

Fig. 2.2-31 Model F-1, 115% Load, View 2, Shank Suction Side
Maximum Principal Shear (psi)

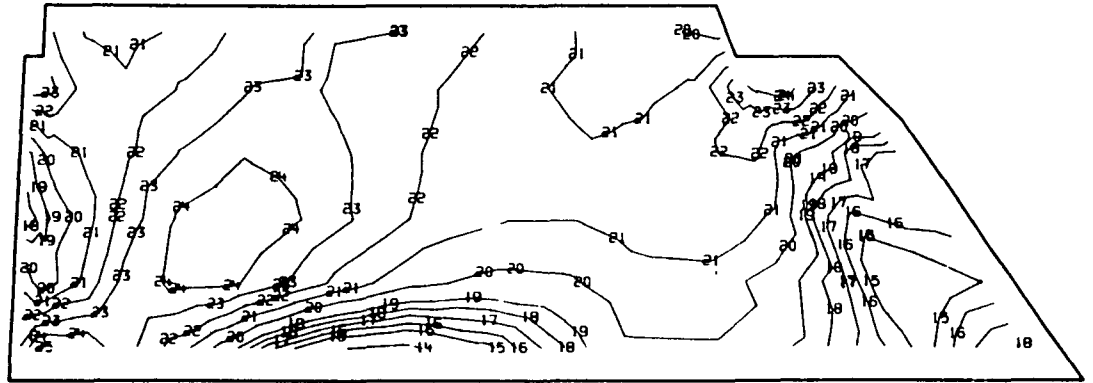

1	-1.500000E 05	12	-4.000000E 04	23	5.000000E 04
2	-1.400000E 05	13	-3.000000E 04	24	6.000000E 04
3	-1.300000E 05	14	-2.000000E 04	25	7.000000E 04
4	-1.200000E 05	15	-1.000000E 04	26	8.000000E 04
5	-1.100000E 05	16	-5.000000E 03	27	9.000000E 04
6	-1.000000E 05	17	0.0	28	1.000000E 05
7	-9.000000E 04	18	5.000000E 03	29	1.100000E 05
8	-8.000000E 04	19	1.000000E 04	30	1.200000E 05
9	-7.000000E 04	20	2.000000E 04	31	1.300000E 05
10	-6.000000E 04	21	3.000000E 04	32	1.400000E 05
11	-5.000000E 04	22	4.000000E 04	33	1.500000E 05

Fig. 2.2-32 Model F-1, FPL Load, View 2, Shank Pressure Side
Major Principal Stress (psi)

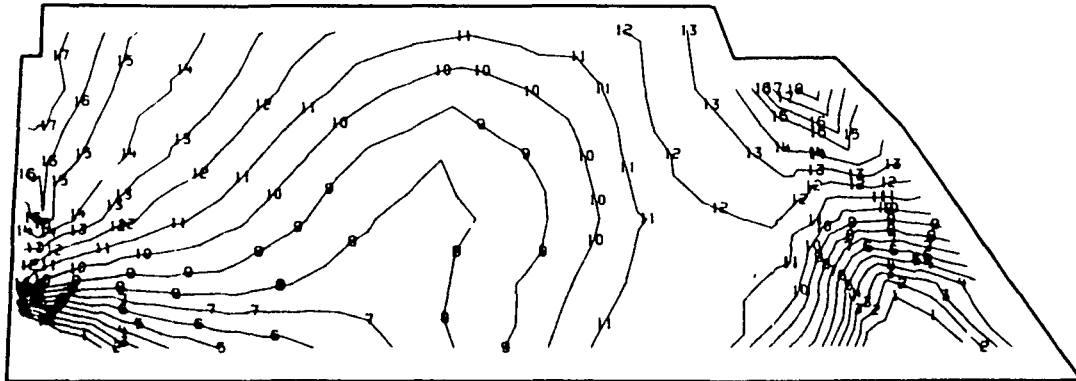

1	-1.500000E 05	12	-4.000000E 04	23	5.000000E 04
2	-1.400000E 05	13	-3.000000E 04	24	6.000000E 04
3	-1.300000E 05	14	-2.000000E 04	25	7.000000E 04
4	-1.200000E 05	15	-1.000000E 04	26	8.000000E 04
5	-1.100000E 05	16	-5.000000E 03	27	9.000000E 04
6	-1.000000E 05	17	0.0	28	1.000000E 05
7	-9.000000E 04	18	5.000000E 03	29	1.100000E 05
8	-8.000000E 04	19	1.000000E 04	30	1.200000E 05
9	-7.000000E 04	20	2.000000E 04	31	1.300000E 05
10	-6.000000E 04	21	3.000000E 04	32	1.400000E 05
11	-5.000000E 04	22	4.000000E 04	33	1.500000E 05

Fig. 2.2-33 Model F-1, FPL Load, View 2, Shank Pressure Side
Minor Principal Stress (psi)

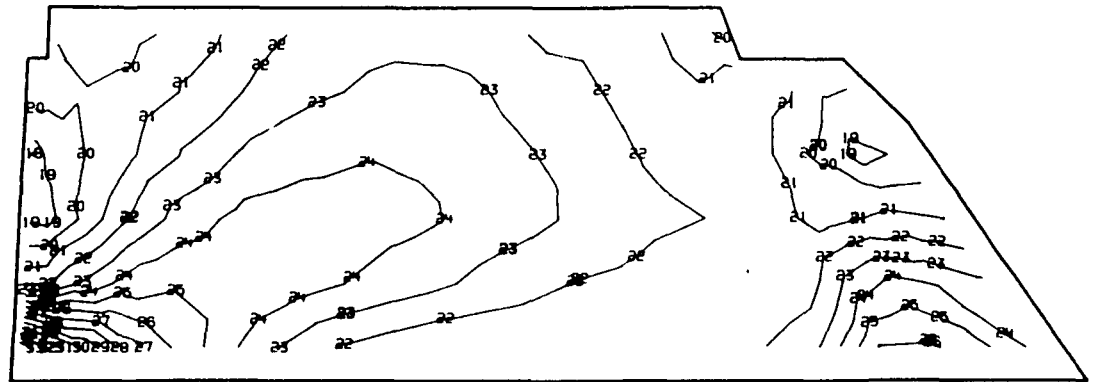

1	-1.500000E 05	12	-4.000000E 04	23	5.000000E 04
2	-1.400000E 05	13	-3.000000E 04	24	6.000000E 04
3	-1.300000E 05	14	-2.000000E 04	25	7.000000E 04
4	-1.200000E 05	15	-1.000000E 04	26	8.000000E 04
5	-1.100000E 05	16	-5.000000E 03	27	9.000000E 04
6	-1.000000E 05	17	0.0	28	1.000000E 05
7	-9.000000E 04	18	5.000000E 03	29	1.100000E 05
8	-8.000000E 04	19	1.000000E 04	30	1.200000E 05
9	-7.000000E 04	20	2.000000E 04	31	1.300000E 05
10	-6.000000E 04	21	3.000000E 04	32	1.400000E 05
11	-5.000000E 04	22	4.000000E 04	33	1.500000E 05

Fig. 2.2-34 Model F-1, FPL Load, View 2, Shank Pressure Side
Maximum Principal Shear (psi)

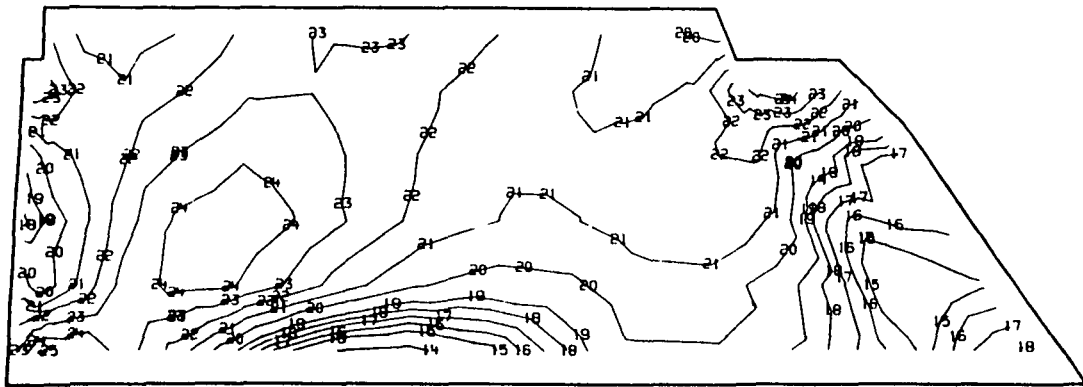

1	-1.500000E 05	12	-4.000000E 04	23	5.000000E 04
2	-1.400000E 05	13	-3.000000E 04	24	6.000000E 04
3	-1.300000E 05	14	-2.000000E 04	25	7.000000E 04
4	-1.200000E 05	15	-1.000000E 04	26	8.000000E 04
5	-1.100000E 05	16	-5.000000E 03	27	9.000000E 04
6	-1.000000E 05	17	0.0	28	1.000000E 05
7	-9.000000E 04	18	5.000000E 03	29	1.100000E 05
8	-8.000000E 04	19	1.000000E 04	30	1.200000E 05
9	-7.000000E 04	20	2.000000E 04	31	1.300000E 05
10	-6.000000E 04	21	3.000000E 04	32	1.400000E 05
11	-5.000000E 04	22	4.000000E 04	33	1.500000E 05

Fig. 2.2-35 Model F-1, 115% Load, View 2, Shank Pressure Side
Major Principal Stress (psi)

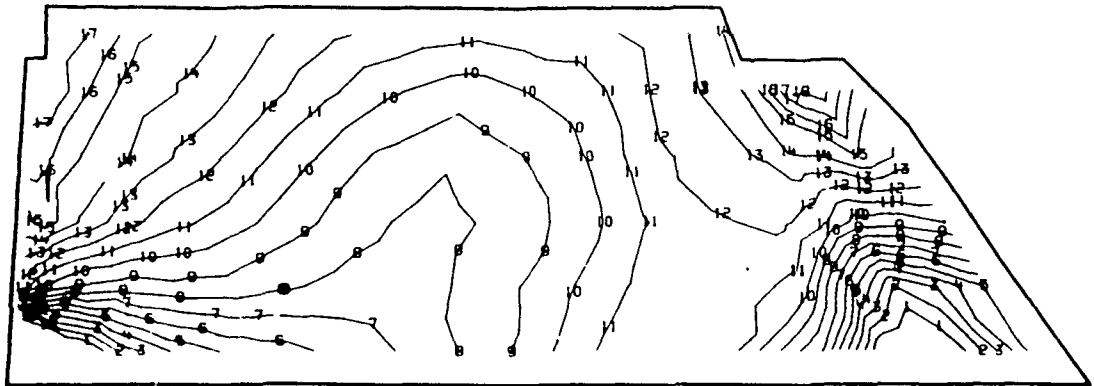

1	-1.500000E 05	12	-4.000000E 04	23	5.000000E 04
2	-1.400000E 05	13	-3.000000E 04	24	6.000000E 04
3	-1.300000E 05	14	-2.000000E 04	25	7.000000E 04
4	-1.200000E 05	15	-1.000000E 04	26	8.000000E 04
5	-1.100000E 05	16	-5.000000E 03	27	9.000000E 04
6	-1.000000E 05	17	0.0	28	1.000000E 05
7	-9.000000E 04	18	5.000000E 03	29	1.100000E 05
8	-8.000000E 04	19	1.000000E 04	30	1.200000E 05
9	-7.000000E 04	20	2.000000E 04	31	1.300000E 05
10	-6.000000E 04	21	3.000000E 04	32	1.400000E 05
11	-5.000000E 04	22	4.000000E 04	33	1.500000E 05

Fig. 2.2-36 Model F-1, 115% Load, View 2, Shank Pressure Side
Minor Principal Stress (psi)

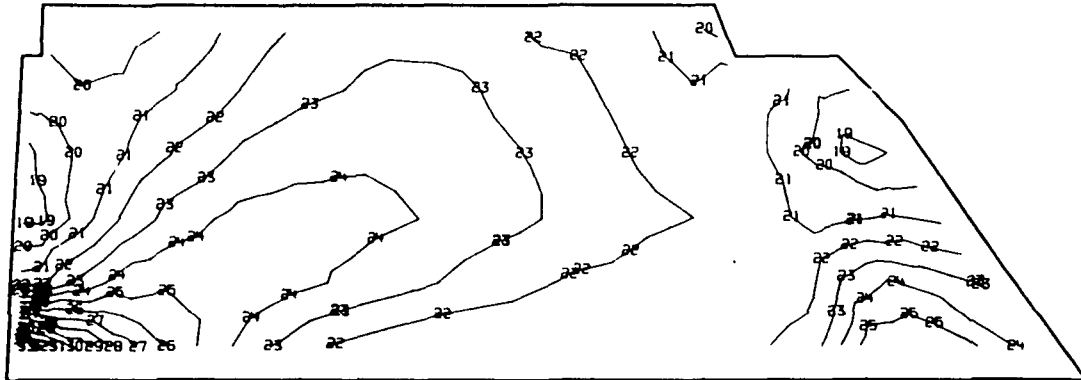

1	-1.500000E 05	12	-4.000000E 04	23	5.000000E 04
2	-1.400000E 05	13	-3.000000E 04	24	6.000000E 04
3	-1.300000E 05	14	-2.000000E 04	25	7.000000E 04
4	-1.200000E 05	15	-1.000000E 04	26	8.000000E 04
5	-1.100000E 05	16	-5.000000E 03	27	9.000000E 04
6	-1.000000E 05	17	0.0	28	1.000000E 05
7	-9.000000E 04	18	5.000000E 03	29	1.100000E 05
8	-8.000000E 04	19	1.000000E 04	30	1.200000E 05
9	-7.000000E 04	20	2.000000E 04	31	1.300000E 05
10	-6.000000E 04	21	3.000000E 04	32	1.400000E 05
11	-5.000000E 04	22	4.000000E 04	33	1.500000E 05

Fig. 2.2-37 Model F-1, 115% Load, View 2, Shank Pressure Side
Maximum Principal Shear (psi)

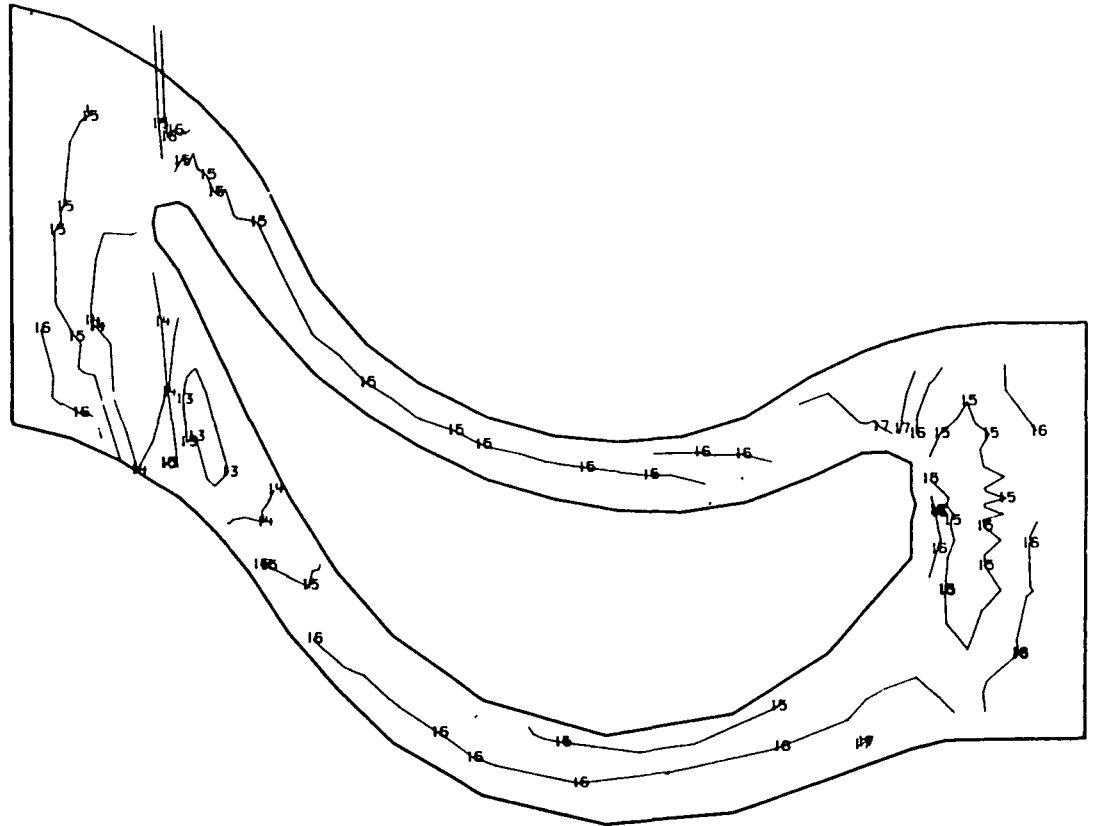

1	-1.500000E 05	12	-4.000000E 04	23	5.000000E 04
2	-1.400000E 05	13	-3.000000E 04	24	6.000000E 04
3	-1.300000E 05	14	-2.000000E 04	25	7.000000E 04
4	-1.200000E 05	15	-1.000000E 04	26	8.000000E 04
5	-1.100000E 05	16	-5.000000E 03	27	9.000000E 04
6	-1.000000E 05	17	0.0	28	1.000000E 05
7	-9.000000E 04	18	5.000000E 03	29	1.100000E 05
8	-8.000000E 04	19	1.000000E 04	30	1.200000E 05
9	-7.000000E 04	20	2.000000E 04	31	1.300000E 05
10	-6.000000E 04	21	3.000000E 04	32	1.400000E 05
11	-5.000000E 04	22	4.000000E 04	33	1.500000E 05

Fig. 2.2-38 Model F-1, FPL Load, View 3, Platform Top Major Principal Shear (psi)

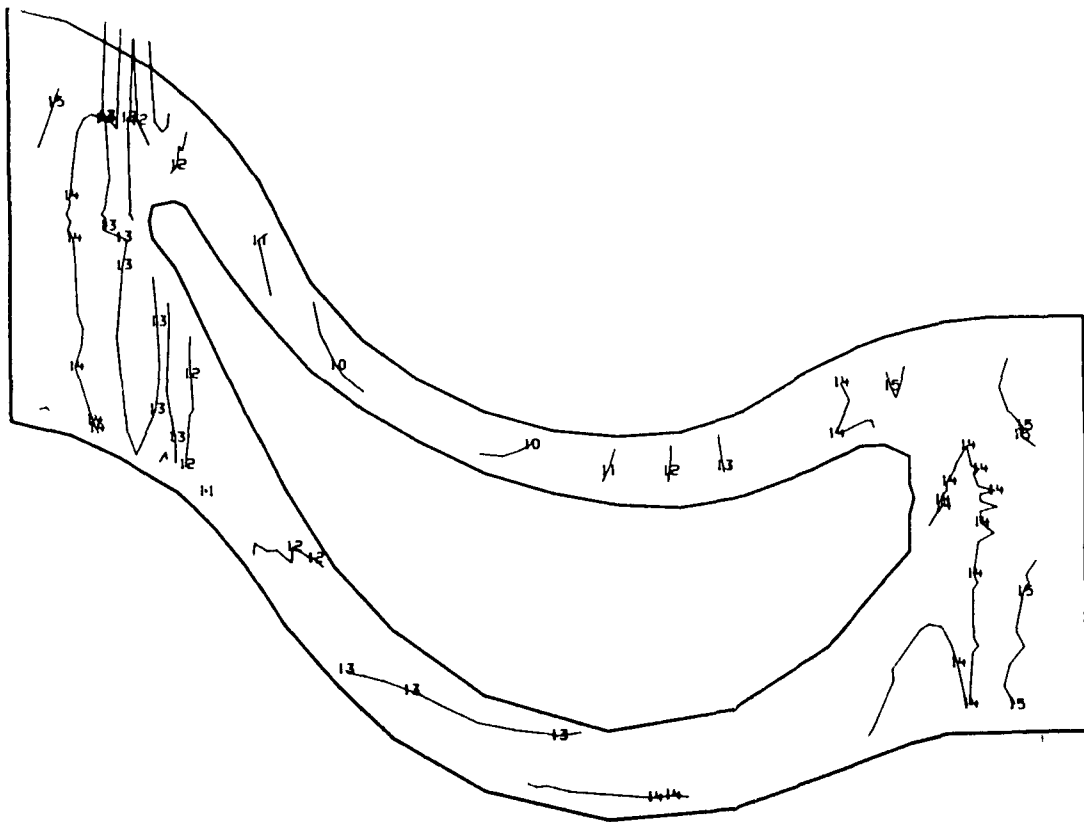

1	-1.500000E 05	12	-4.000000E 04	23	5.000000E 04
2	-1.400000E 05	13	-3.000000E 04	24	6.000000E 04
3	-1.300000E 05	14	-2.000000E 04	25	7.000000E 04
4	-1.200000E 05	15	-1.000000E 04	26	8.000000E 04
5	-1.100000E 05	16	-5.000000E 03	27	9.000000E 04
6	-1.000000E 05	17	0.0	28	1.000000E 05
7	-9.000000E 04	18	5.000000E 03	29	1.100000E 05
8	-8.000000E 04	19	1.000000E 04	30	1.200000E 05
9	-7.000000E 04	20	2.000000E 04	31	1.300000E 05
10	-6.000000E 04	21	3.000000E 04	32	1.400000E 05
11	-5.000000E 04	22	4.000000E 04	33	1.500000E 05

Fig. 2.2-39 Model F-1, FPL Load, View 3, Platform Top Minor Principal Stress (psi)

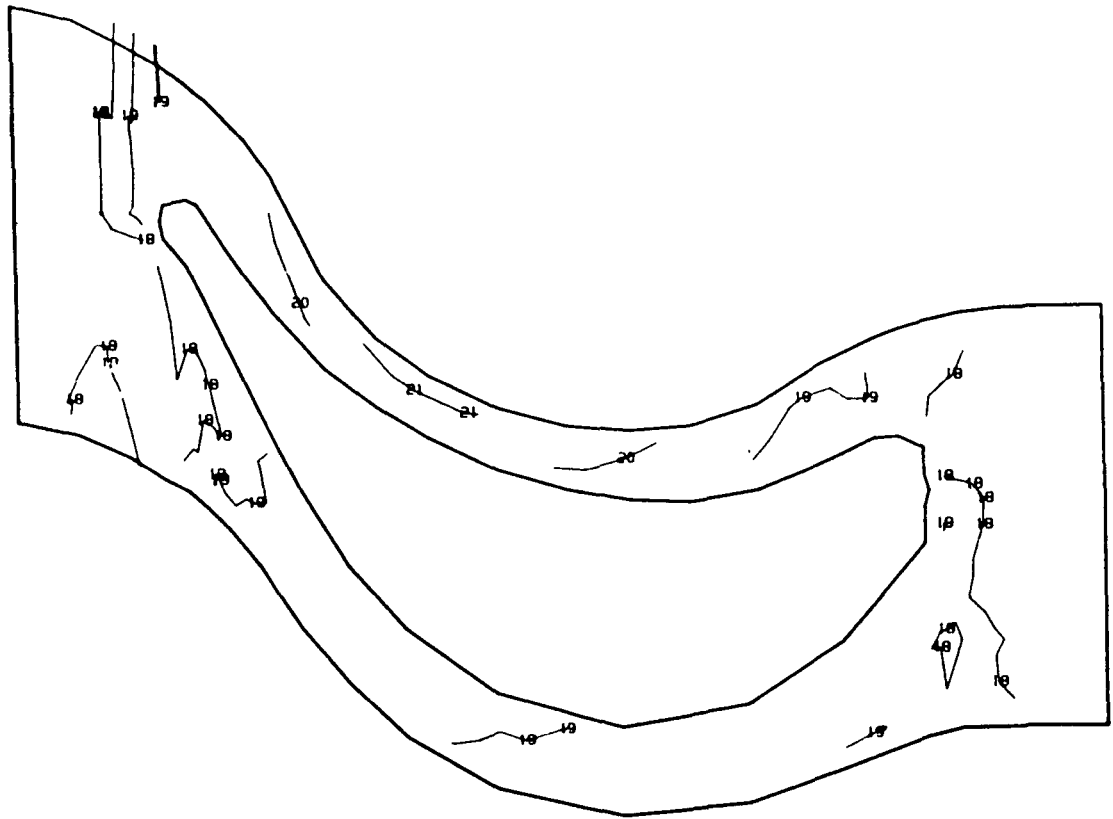

1	-1.500000E	05	12	-4.000000E	04	23	5.000000E	04
2	-1.400000E	05	13	-3.000000E	04	24	6.000000E	04
3	-1.300000E	05	14	-2.000000E	04	25	7.000000E	04
4	-1.200000E	05	15	-1.000000E	04	26	8.000000E	04
5	-1.100000E	05	16	-5.000000E	03	27	9.000000E	04
6	-1.000000E	05	17	0.0		28	1.000000E	05
7	-9.000000E	04	18	5.000000E	03	29	1.100000E	05
8	-8.000000E	04	19	1.000000E	04	30	1.200000E	05
9	-7.000000E	04	20	2.000000E	04	31	1.300000E	05
10	-6.000000E	04	21	3.000000E	04	32	1.400000E	05
11	-5.000000E	04	22	4.000000E	04	33	1.500000E	05

Fig. 2.2-40 Model F-1, FPL Load, View 3, Platform Top Maximum Principal Shear (psi)

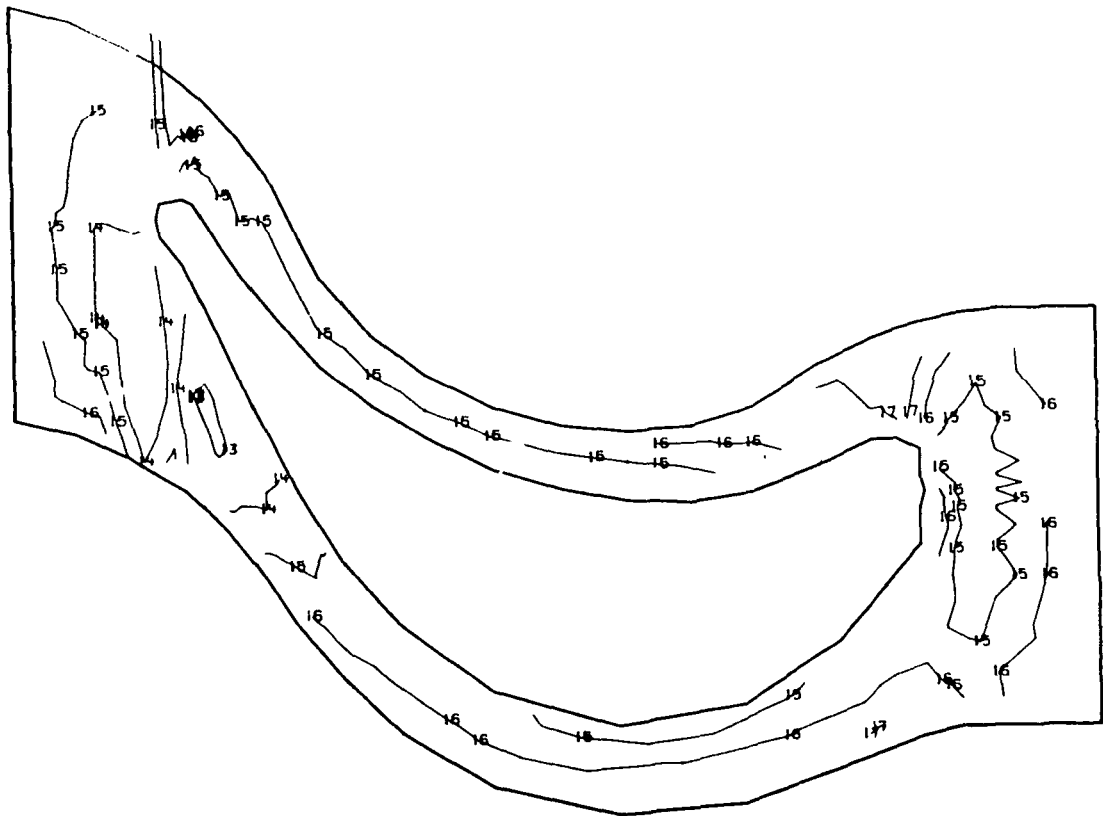

1	-1.500000E 05	12	-4.000000E 04	23	5.000000E 04
2	-1.400000E 05	13	-3.000000E 04	24	6.000000E 04
3	-1.300000E 05	14	-2.000000E 04	25	7.000000E 04
4	-1.200000E 05	15	-1.000000E 04	26	8.000000E 04
5	-1.100000E 05	16	-5.000000E 03	27	9.000000E 04
6	-1.000000E 05	17	0.0	28	1.000000E 05
7	-9.000000E 04	18	5.000000E 03	29	1.100000E 05
8	-8.000000E 04	19	1.000000E 04	30	1.200000E 05
9	-7.000000E 04	20	2.000000E 04	31	1.300000E 05
10	-6.000000E 04	21	3.000000E 04	32	1.400000E 05
11	-5.000000E 04	22	4.000000E 04	33	1.500000E 05

Fig. 2.2-41 Model 115%, FPL Load, View 3, Platform Top Major Principal Stress (psi)

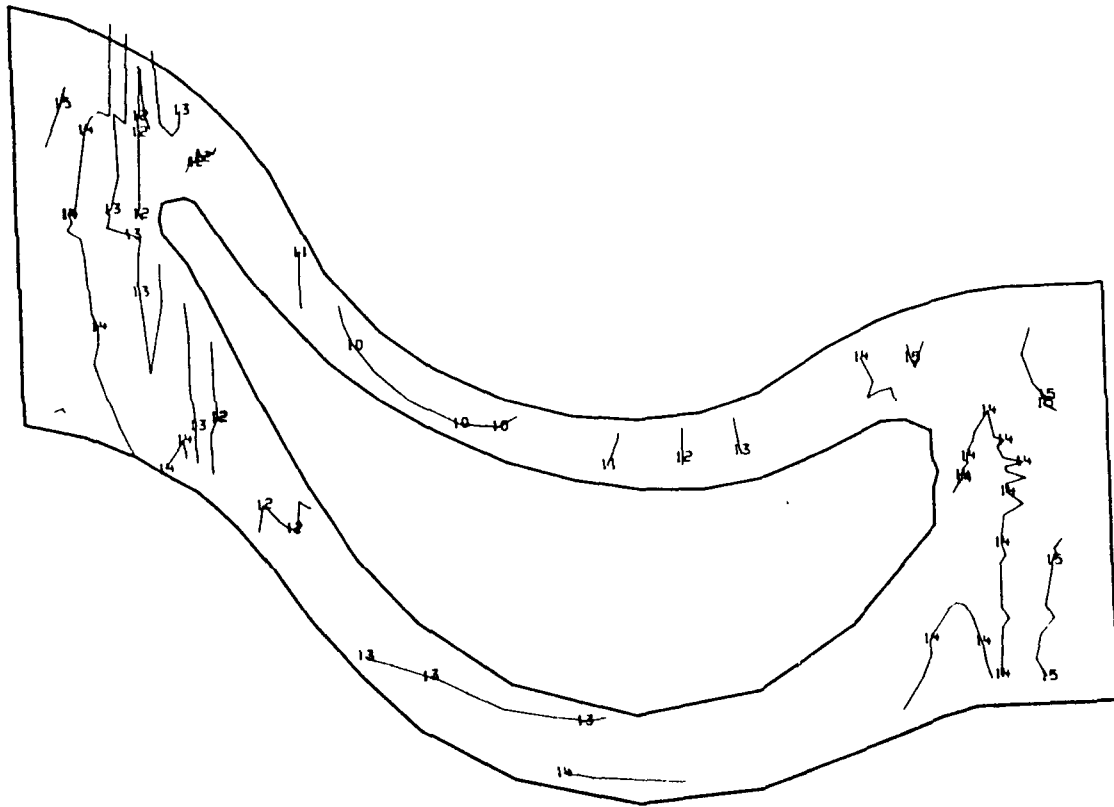

1	-1.500000E 05	12	-4.000000E 04	23	5.000000E 04
2	-1.400000E 05	13	-3.000000E 04	24	6.000000E 04
3	-1.300000E 05	14	-2.000000E 04	25	7.000000E 04
4	-1.200000E 05	15	-1.000000E 04	26	8.000000E 04
5	-1.100000E 05	16	-5.000000E 03	27	9.000000E 04
6	-1.000000E 05	17	0.0	28	1.000000E 05
7	-9.000000E 04	18	5.000000E 03	29	1.100000E 05
8	-8.000000E 04	19	1.000000E 04	30	1.200000E 05
9	-7.000000E 04	20	2.000000E 04	31	1.300000E 05
10	-6.000000E 04	21	3.000000E 04	32	1.400000E 05
11	-5.000000E 04	22	4.000000E 04	33	1.500000E 05

Fig. 2.2-42 Model 115%, FPL Load, View 3, Platform Top Minor Principal Stress (psi)

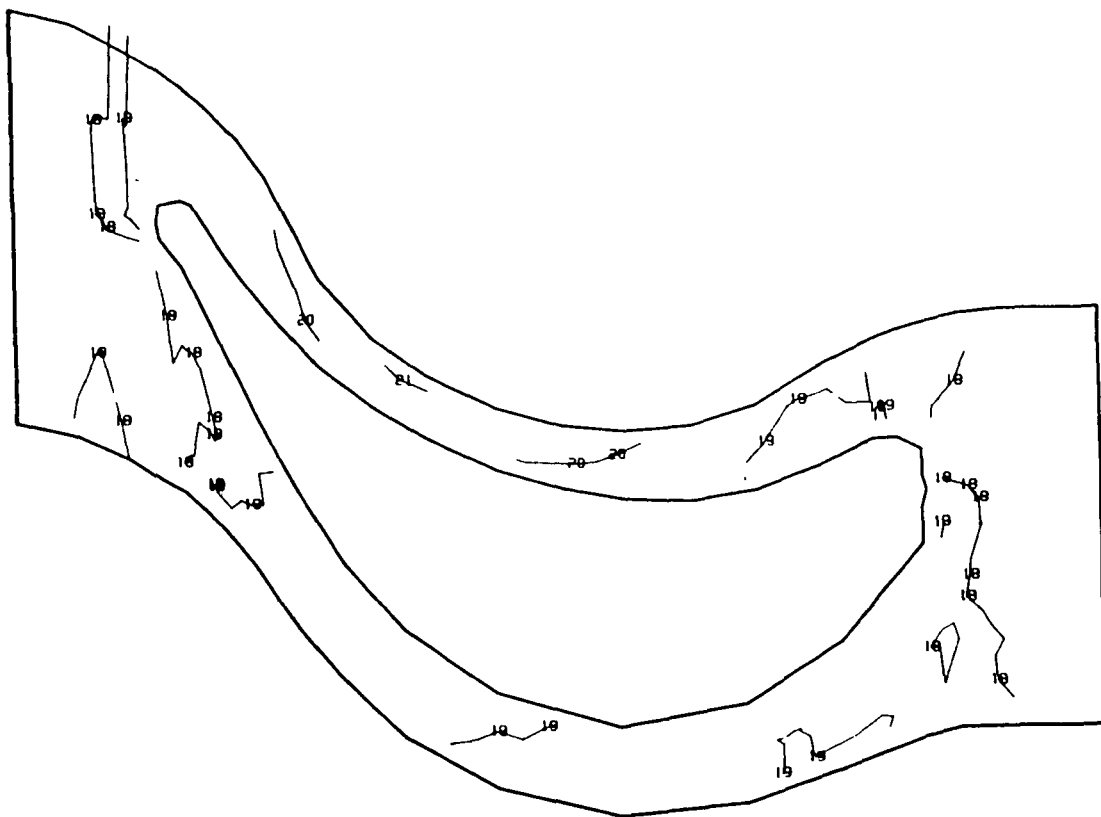

1	-1.500000E 05	12	-4.000000E 04	23	5.000000E 04
2	-1.400000E 05	13	-3.000000E 04	24	6.000000E 04
3	-1.300000E 05	14	-2.000000E 04	25	7.000000E 04
4	-1.200000E 05	15	-1.000000E 04	26	8.000000E 04
5	-1.100000E 05	16	-5.000000E 03	27	9.000000E 04
6	-1.000000E 05	17	0.0	28	1.000000E 05
7	-9.000000E 04	18	5.000000E 03	29	1.100000E 05
8	-8.000000E 04	19	1.000000E 04	30	1.200000E 05
9	-7.000000E 04	20	2.000000E 04	31	1.300000E 05
10	-6.000000E 04	21	3.000000E 04	32	1.400000E 05
11	-5.000000E 04	22	4.000000E 04	33	1.500000E 05

Fig. 2.2-43 Model 115%, 115% Load, View 3, Platform Top Maximum Principal Shear (psi)

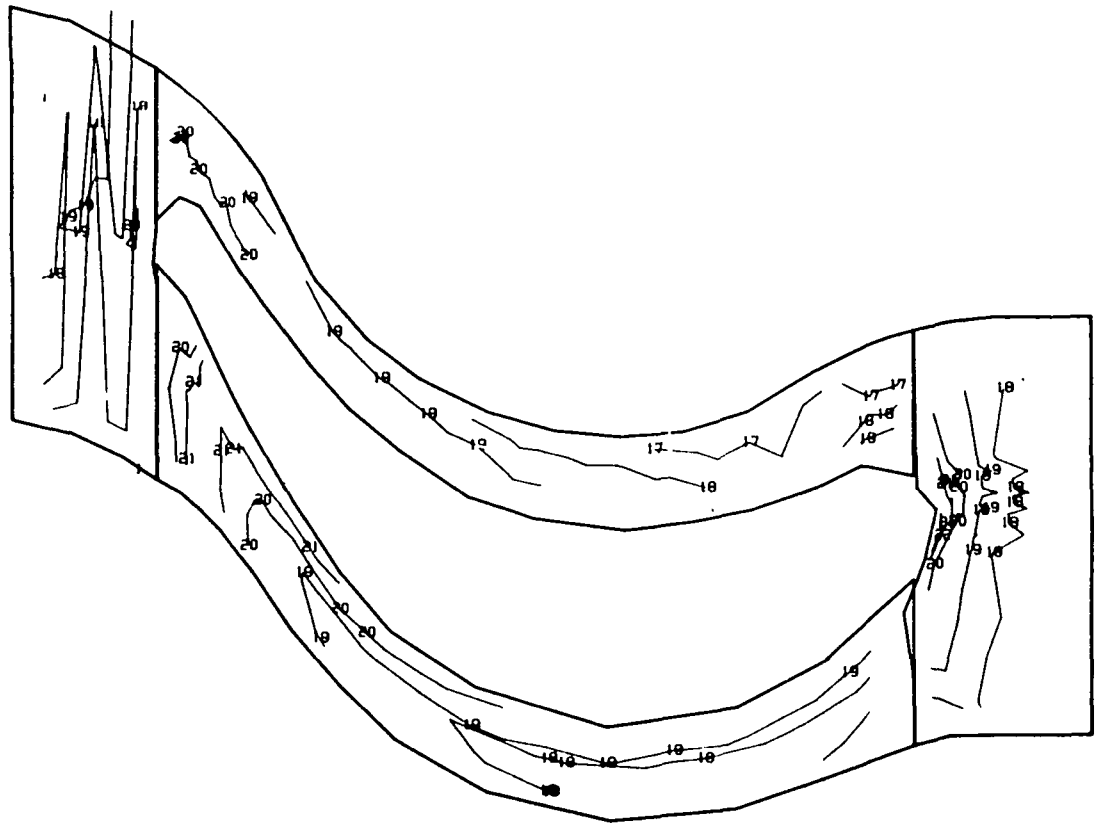

1	-1.500000E	05	12	-4.000000E	04	23	5.000000E	04
2	-1.400000E	05	13	-3.000000E	04	24	6.000000E	04
3	-1.300000E	05	14	-2.000000E	04	25	7.000000E	04
4	-1.200000E	05	15	-1.000000E	04	26	8.000000E	04
5	-1.100000E	05	16	-5.000000E	03	27	9.000000E	04
6	-1.000000E	05	17	0.0		28	1.000000E	05
7	-9.000000E	04	18	5.000000E	03	29	1.100000E	05
8	-8.000000E	04	19	1.000000E	04	30	1.200000E	05
9	-7.000000E	04	20	2.000000E	04	31	1.300000E	05
10	-6.000000E	04	21	3.000000E	04	32	1.400000E	05
11	-5.000000E	04	22	4.000000E	04	33	1.500000E	05

Fig. 2.2-44 Model F-1, FPL Load, View 3, Platform Bottom Major Principal Stress (psi)

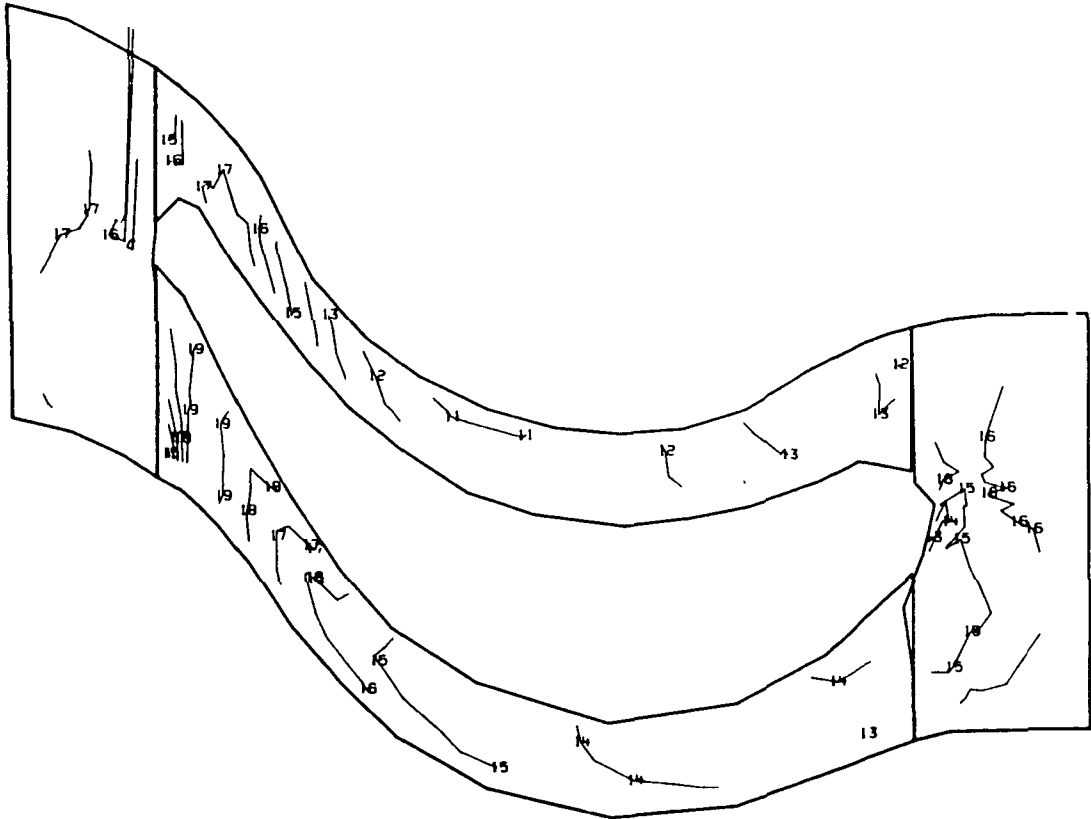

1	-1.500000E 05	12	-4.000000E 04	23	5.000000E 04
2	-1.400000E 05	13	-3.000000E 04	24	6.000000E 04
3	-1.300000E 05	14	-2.000000E 04	25	7.000000E 04
4	-1.200000E 05	15	-1.000000E 04	26	8.000000E 04
5	-1.100000E 05	16	-5.000000E 03	27	9.000000E 04
6	-1.000000E 05	17	0.0	28	1.000000E 05
7	-9.000000E 04	18	5.000000E 03	29	1.100000E 05
8	-8.000000E 04	19	1.000000E 04	30	1.200000E 05
9	-7.000000E 04	20	2.000000E 04	31	1.300000E 05
10	-6.000000E 04	21	3.000000E 04	32	1.400000E 05
11	-5.000000E 04	22	4.000000E 04	33	1.500000E 05

Fig. 2.2-45 Model F-1, FPL Load, View 3, Platform Bottom Minor Principal Stress (psi)

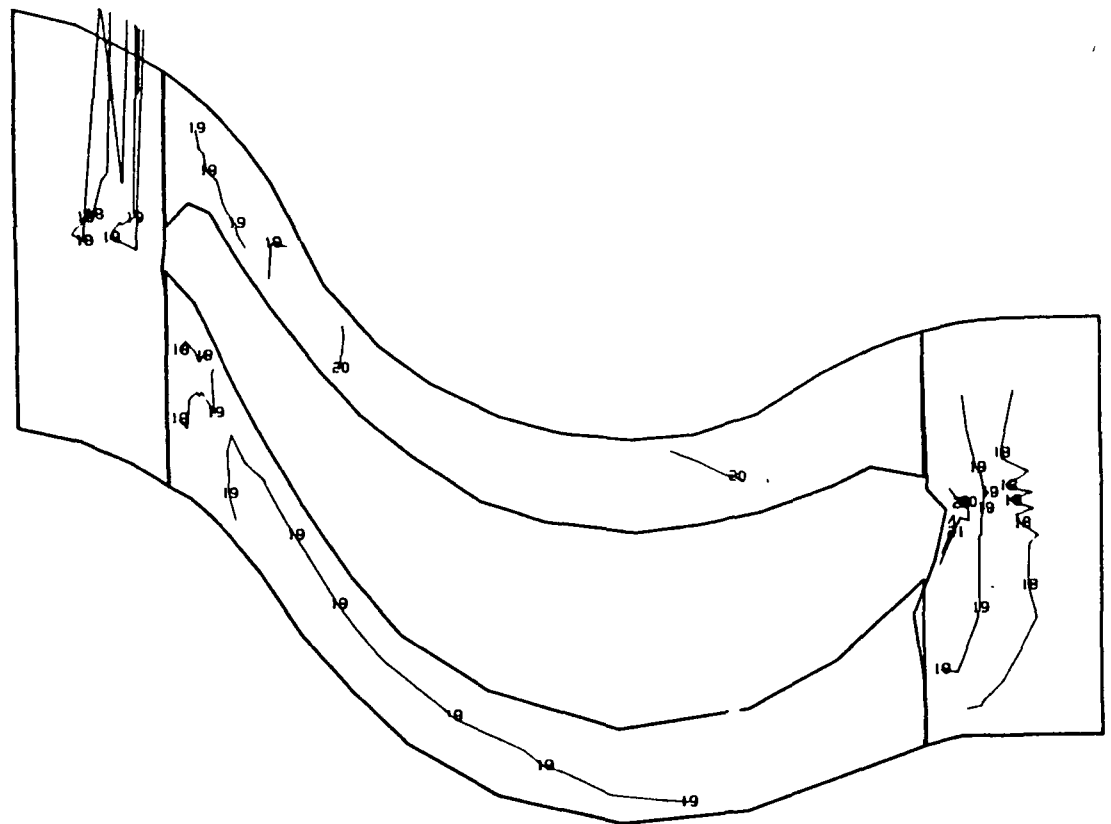

1	-1.500000E 05	12	-4.000000E 04	23	5.000000E 04
2	-1.400000E 05	13	-3.000000E 04	24	6.000000E 04
3	-1.300000E 05	14	-2.000000E 04	25	7.000000E 04
4	-1.200000E 05	15	-1.000000E 04	26	8.000000E 04
5	-1.100000E 05	16	-5.000000E 03	27	9.000000E 04
6	-1.000000E 05	17	0.0	28	1.000000E 05
7	-9.000000E 04	18	5.000000E 03	29	1.100000E 05
8	-8.000000E 04	19	1.000000E 04	30	1.200000E 05
9	-7.000000E 04	20	2.000000E 04	31	1.300000E 05
10	-6.000000E 04	21	3.000000E 04	32	1.400000E 05
11	-5.000000E 04	22	4.000000E 04	33	1.500000E 05

Fig. 2.2-46 Model F-1, FPL Load, View 3, Platform Bottom Maximum Principal Shear (psi)

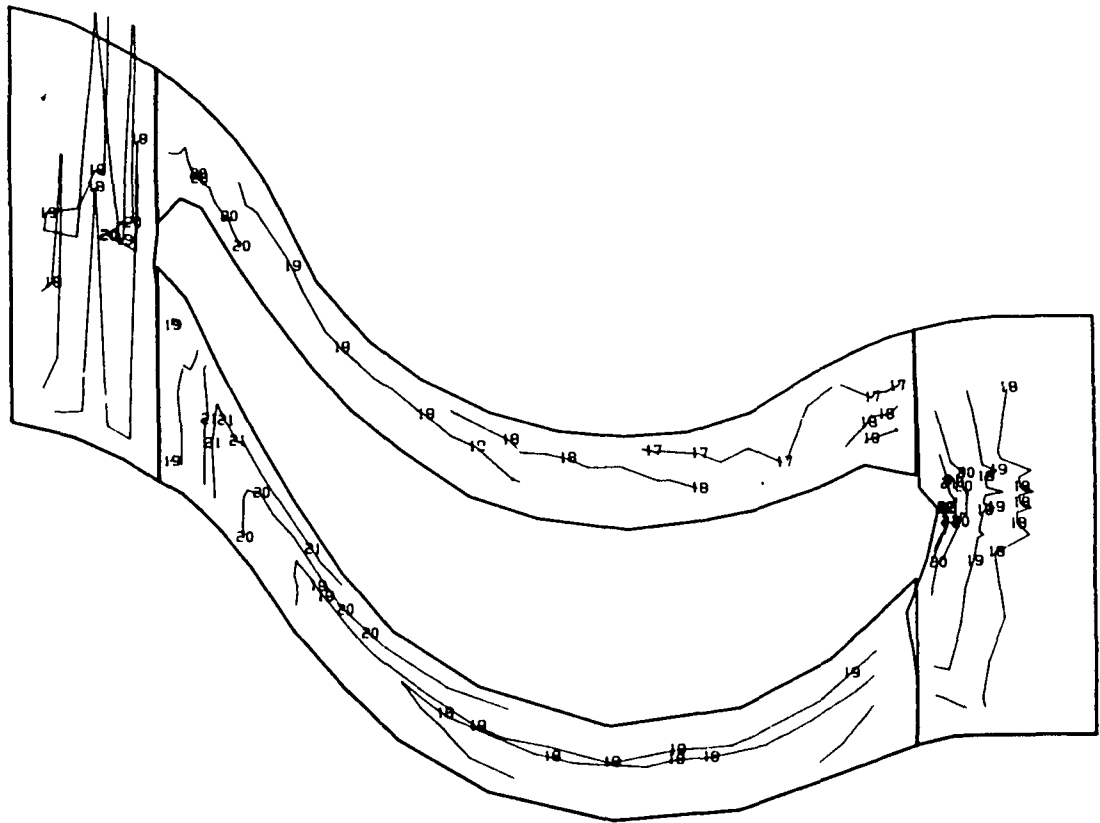

1	-1.500000E 05	12	-4.000000E 04	23	5.000000E 04
2	-1.400000E 05	13	-3.000000E 04	24	6.000000E 04
3	-1.300000E 05	14	-2.000000E 04	25	7.000000E 04
4	-1.200000E 05	15	-1.000000E 04	26	8.000000E 04
5	-1.100000E 05	16	-5.000000E 03	27	9.000000E 04
6	-1.000000E 05	17	0.0	28	1.000000E 05
7	-9.000000E 04	18	5.000000E 03	29	1.100000E 05
8	-8.000000E 04	19	1.000000E 04	30	1.200000E 05
9	-7.000000E 04	20	2.000000E 04	31	1.300000E 05
10	-6.000000E 04	21	3.000000E 04	32	1.400000E 05
11	-5.000000E 04	22	4.000000E 04	33	1.500000E 05

Fig. 2.2-47 Model F-1, 115% Load, View 3, Platform Bottom Major Principal Stress (psi)

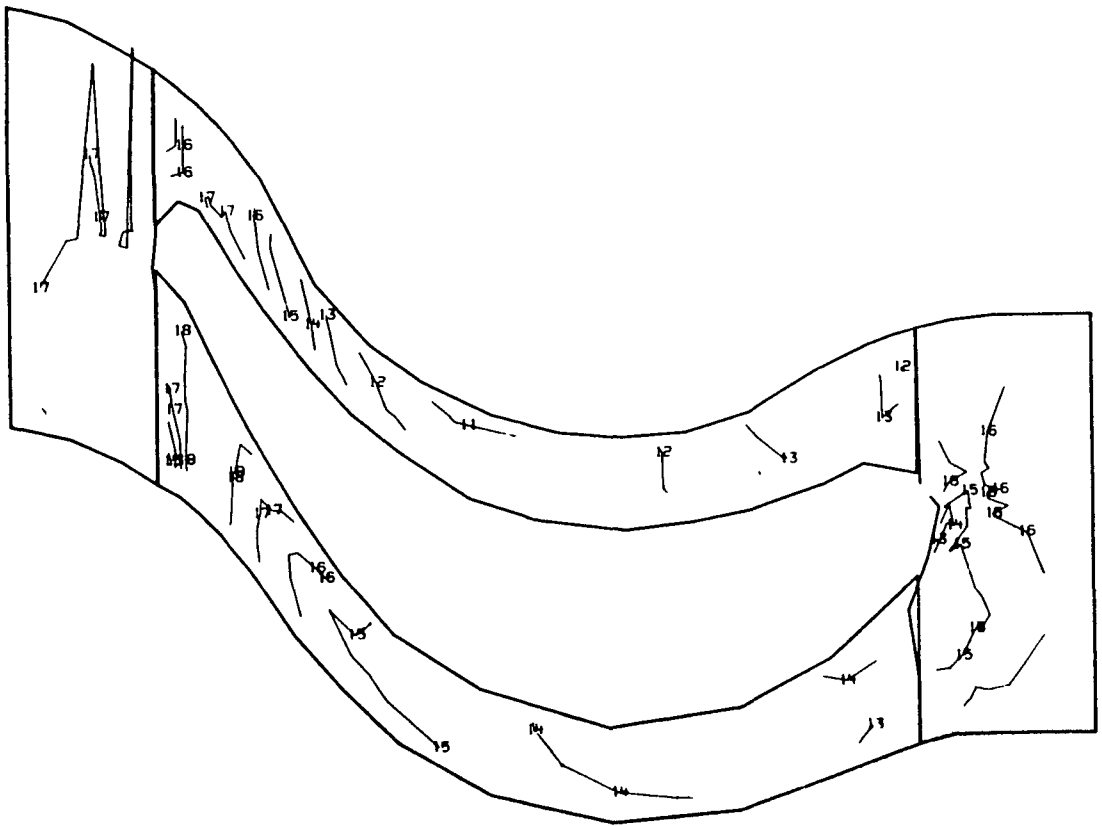

1	-1.500000E 05	05	12	-4.000000E 04	04	23	5.000000E 04	04
2	-1.400000E 05	05	13	-3.000000E 04	04	24	6.000000E 04	04
3	-1.300000E 05	05	14	-2.000000E 04	04	25	7.000000E 04	04
4	-1.200000E 05	05	15	-1.000000E 04	04	26	8.000000E 04	04
5	-1.100000E 05	05	16	-5.000000E 03	03	27	9.000000E 04	04
6	-1.000000E 05	05	17	0.0		28	1.000000E 05	05
7	-9.000000E 04	04	18	5.000000E 03	03	29	1.100000E 05	05
8	-8.000000E 04	04	19	1.000000E 04	04	30	1.200000E 05	05
9	-7.000000E 04	04	20	2.000000E 04	04	31	1.300000E 05	05
10	-6.000000E 04	04	21	3.000000E 04	04	32	1.400000E 05	05
11	-5.000000E 04	04	22	4.000000E 04	04	33	1.500000E 05	05

Fig. 2.2-48 Model F-1, 115% Load, View 3, Platform Bottom Minor Principal Stress (psi)

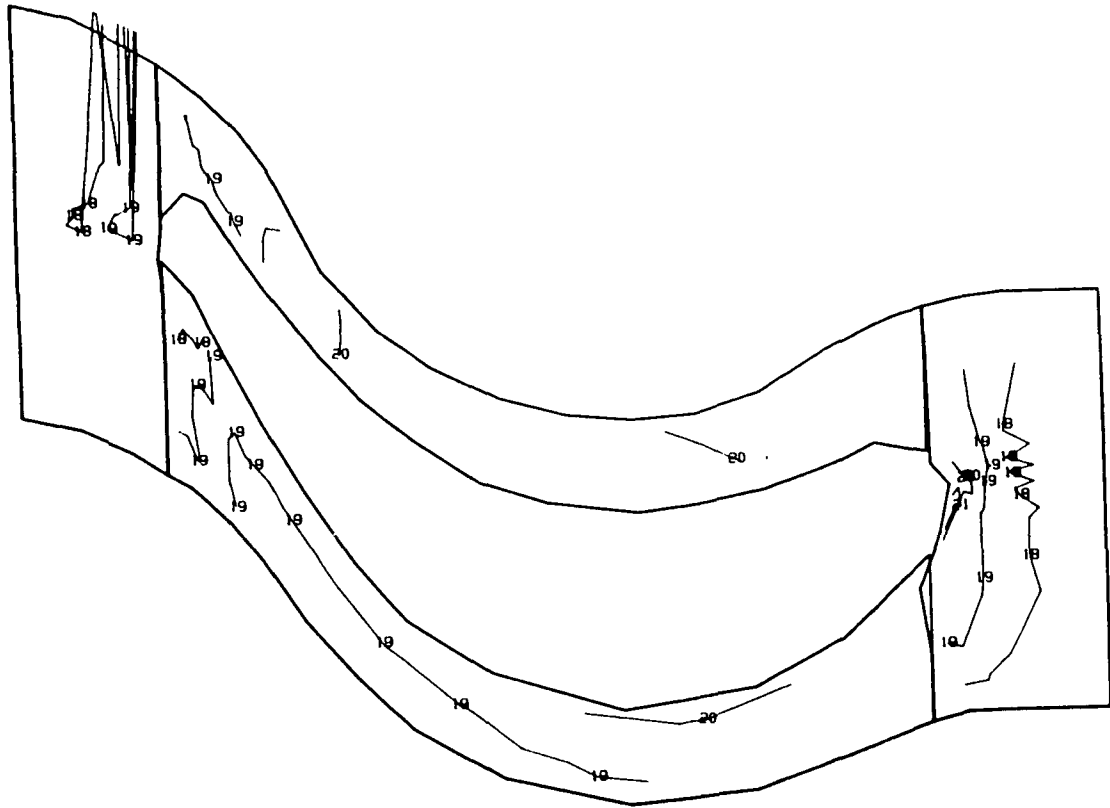

1	-1.500000E 05	05	12	-4.000000E 04	04	23	5.000000E 04	04
2	-1.400000E 05	05	13	-3.000000E 04	04	24	6.000000E 04	04
3	-1.300000E 05	05	14	-2.000000E 04	04	25	7.000000E 04	04
4	-1.200000E 05	05	15	-1.000000E 04	04	26	8.000000E 04	04
5	-1.100000E 05	05	16	-5.000000E 03	03	27	9.000000E 04	04
6	-1.000000E 05	05	17	0.0		28	1.000000E 05	05
7	-9.000000E 04	04	18	5.000000E 03	03	29	1.100000E 05	05
8	-8.000000E 04	04	19	1.000000E 04	04	30	1.200000E 05	05
9	-7.000000E 04	04	20	2.000000E 04	04	31	1.300000E 05	05
10	-6.000000E 04	04	21	3.000000E 04	04	32	1.400000E 05	05
11	-5.000000E 04	04	22	4.000000E 04	04	33	1.500000E 05	05

Fig. 2.2-49 Model F-1, 115% Load, View 3, Platform Bottom Maximum Principal Shear (psi)

2.3 HPFTP SECOND STAGE TURBINE BLADE TEMPERATURES AND STRESSES
 AT FPL AND 115% RPL

Surface temperatures are shown in Figs. 2.3-1 through 2.3-12. Surface stresses are shown in Figs. 2.2-13 through 2.3-48.

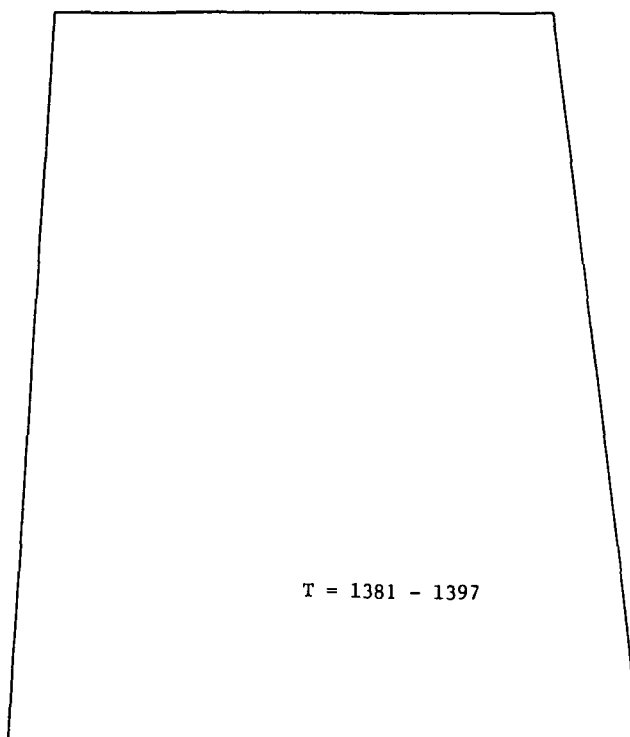

1	-3.000000E 02	14	3.500000E 02	27	1.000000E 03
2	-2.500000E 02	15	4.000000E 02	28	1.050000E 03
3	-2.000000E 02	16	4.500000E 02	29	1.100000E 03
4	-1.500000E 02	17	5.000000E 02	30	1.150000E 03
5	-1.000000E 02	18	5.500000E 02	31	1.200000E 03
6	-5.000000E 01	19	6.000000E 02	32	1.250000E 03
7	0.0	20	6.500000E 02	33	1.300000E 03
8	5.000000E 01	21	7.000000E 02	34	1.350000E 03
9	1.000000E 02	22	7.500000E 02	35	1.400000E 03
10	1.500000E 02	23	8.000000E 02	36	1.450000E 03
11	2.000000E 02	24	8.500000E 02	37	1.500000E 03
12	2.500000E 02	25	9.000000E 02	38	1.550000E 03
13	3.000000E 02	26	9.500000E 02	39	1.600000E 03

Fig. 2.3-1 Model F-2, FPL Load, View 1, Airfoil Suction Side Steady State Surface Temperatures (F)

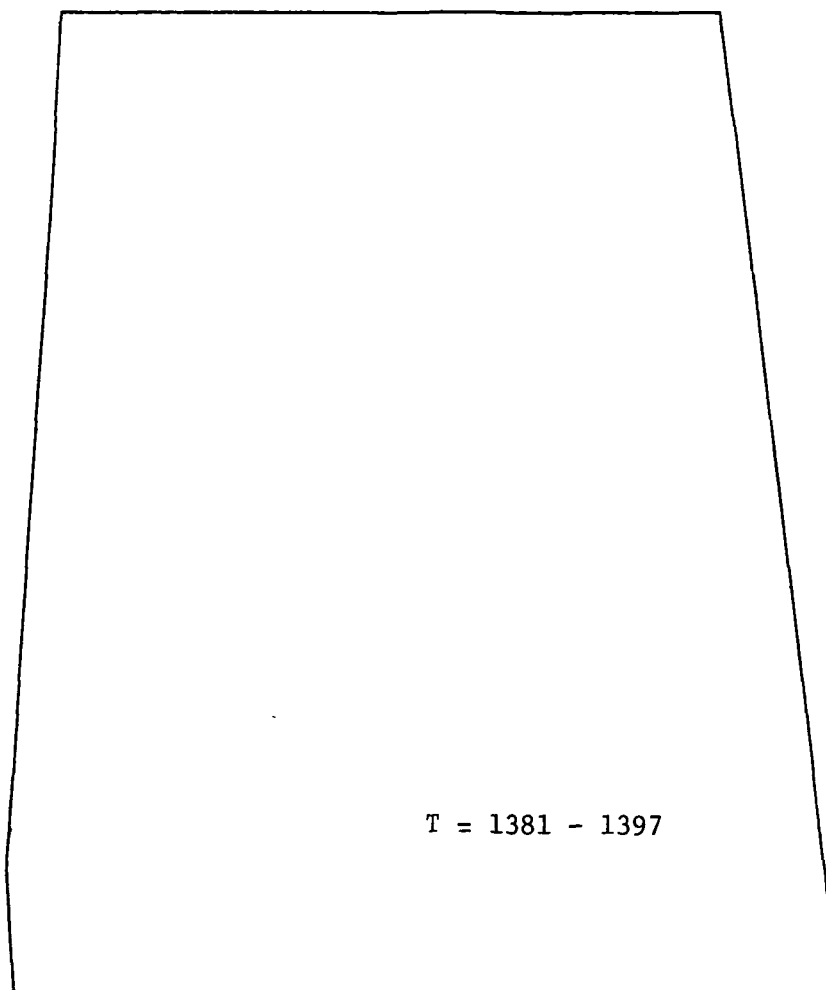

1	-3.000000E 02	14	3.500000E 02	27	1.000000E 03
2	-2.500000E 02	15	4.000000E 02	28	1.050000E 03
3	-2.000000E 02	16	4.500000E 02	29	1.100000E 03
4	-1.500000E 02	17	5.000000E 02	30	1.150000E 03
5	-1.000000E 02	18	5.500000E 02	31	1.200000E 03
6	-5.000000E 01	19	6.000000E 02	32	1.250000E 03
7	0.0	20	6.500000E 02	33	1.300000E 03
8	5.000000E 01	21	7.000000E 02	34	1.350000E 03
9	1.000000E 02	22	7.500000E 02	35	1.400000E 03
10	1.500000E 02	23	8.000000E 02	36	1.450000E 03
11	2.000000E 02	24	8.500000E 02	37	1.500000E 03
12	2.500000E 02	25	9.000000E 02	38	1.550000E 03
13	3.000000E 02	26	9.500000E 02	39	1.600000E 03

Fig. 2.3-2 Model F-2, FPL Load, View 1, Airfoil Pressure Side Steady State Surface Temperatures (F)

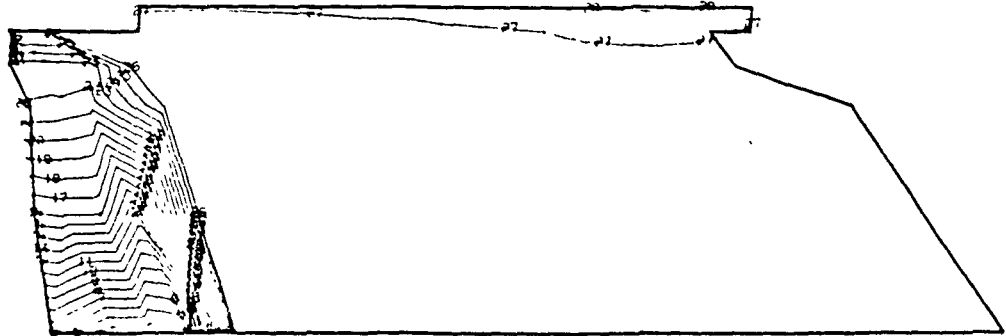

1	-3.000000E 02	14	3.500000E 02	27	1.000000E 03
2	-2.500000E 02	15	4.000000E 02	28	1.050000E 03
3	-2.000000E 02	16	4.500000E 02	29	1.100000E 03
4	-1.500000E 02	17	5.000000E 02	30	1.150000E 03
5	-1.000000E 02	18	5.500000E 02	31	1.200000E 03
6	-5.000000E 01	19	6.000000E 02	32	1.250000E 03
7	0.0	20	6.500000E 02	33	1.300000E 03
8	5.000000E 01	21	7.000000E 02	34	1.350000E 03
9	1.000000E 02	22	7.500000E 02	35	1.400000E 03
10	1.500000E 02	23	8.000000E 02	36	1.450000E 03
11	2.000000E 02	24	8.500000E 02	37	1.500000E 03
12	2.500000E 02	25	9.000000E 02	38	1.550000E 03
13	3.000000E 02	26	9.500000E 02	39	1.600000E 03

Fig. 2.3-3 Model F-2, FPL Load, View 2, Shank Suction Side Steady State Surface Temperatures (F)

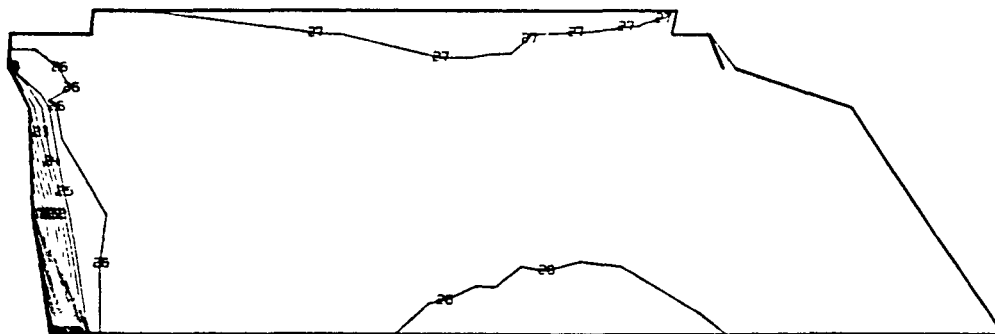

1	-3.000000E 02	14	3.500000E 02	27	1.000000E 03
2	-2.500000E 02	15	4.000000E 02	28	1.050000E 03
3	-2.000000E 02	16	4.500000E 02	29	1.100000E 03
4	-1.500000E 02	17	5.000000E 02	30	1.150000E 03
5	-1.000000E 02	18	5.500000E 02	31	1.200000E 03
6	-5.000000E 01	19	6.000000E 02	32	1.250000E 03
7	0.0	20	6.500000E 02	33	1.300000E 03
8	5.000000E 01	21	7.000000E 02	34	1.350000E 03
9	1.000000E 02	22	7.500000E 02	35	1.400000E 03
10	1.500000E 02	23	8.000000E 02	36	1.450000E 03
11	2.000000E 02	24	8.500000E 02	37	1.500000E 03
12	2.500000E 02	25	9.000000E 02	38	1.550000E 03
13	3.000000E 02	26	9.500000E 02	39	1.600000E 03

Fig. 2.3-4 Model F-2, FPL Load, View 2, Shank Pressure Side Steady State Surface Temperatures (F)

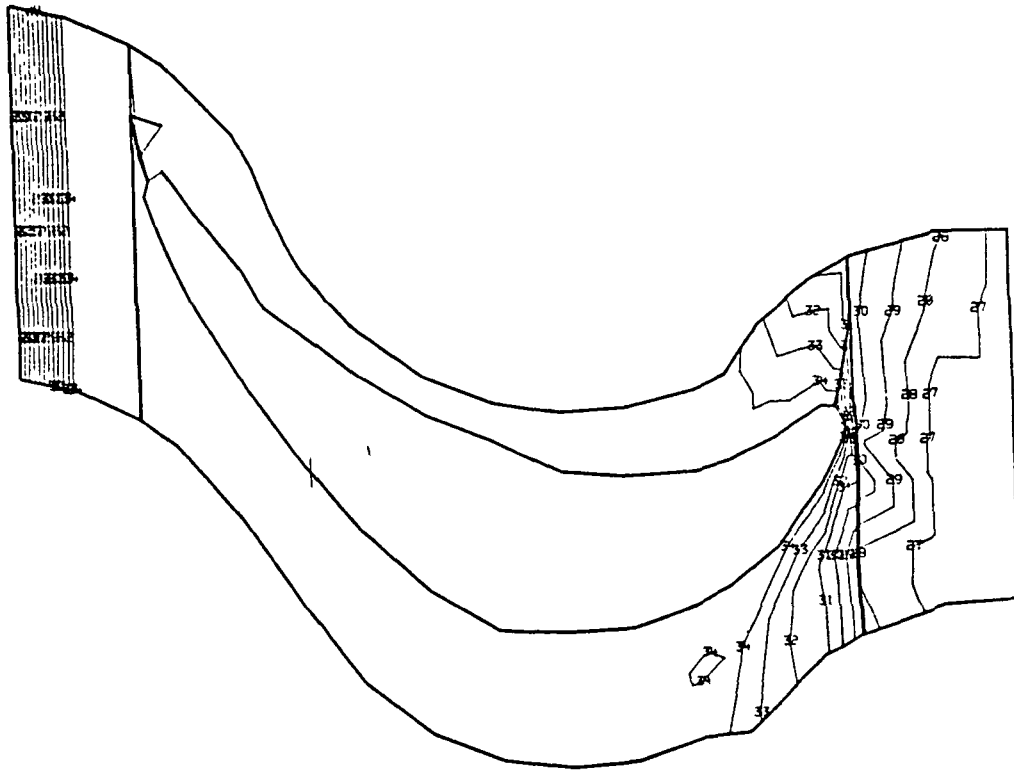

1	-3.000000E 02	14	3.500000E 02	27	1.000000E 03
2	-2.500000E 02	15	4.000000E 02	28	1.050000E 03
3	-2.000000E 02	16	4.500000E 02	29	1.100000E 03
4	-1.500000E 02	17	5.000000E 02	30	1.150000E 03
5	-1.000000E 02	18	5.500000E 02	31	1.200000E 03
6	-5.000000E 01	19	6.000000E 02	32	1.250000E 03
7	0.0	20	6.500000E 02	33	1.300000E 03
8	5.000000E 01	21	7.000000E 02	34	1.350000E 03
9	1.000000E 02	22	7.500000E 02	35	1.400000E 03
10	1.500000E 02	23	8.000000E 02	36	1.450000E 03
11	2.000000E 02	24	8.500000E 02	37	1.500000E 03
12	2.500000E 02	25	9.000000E 02	38	1.550000E 03
13	3.000000E 02	26	9.500000E 02	39	1.600000E 03

Fig. 2.3-5 Model F-2, FPL Load, View 3, Platform Top Steady State Surface Temperatures (F)

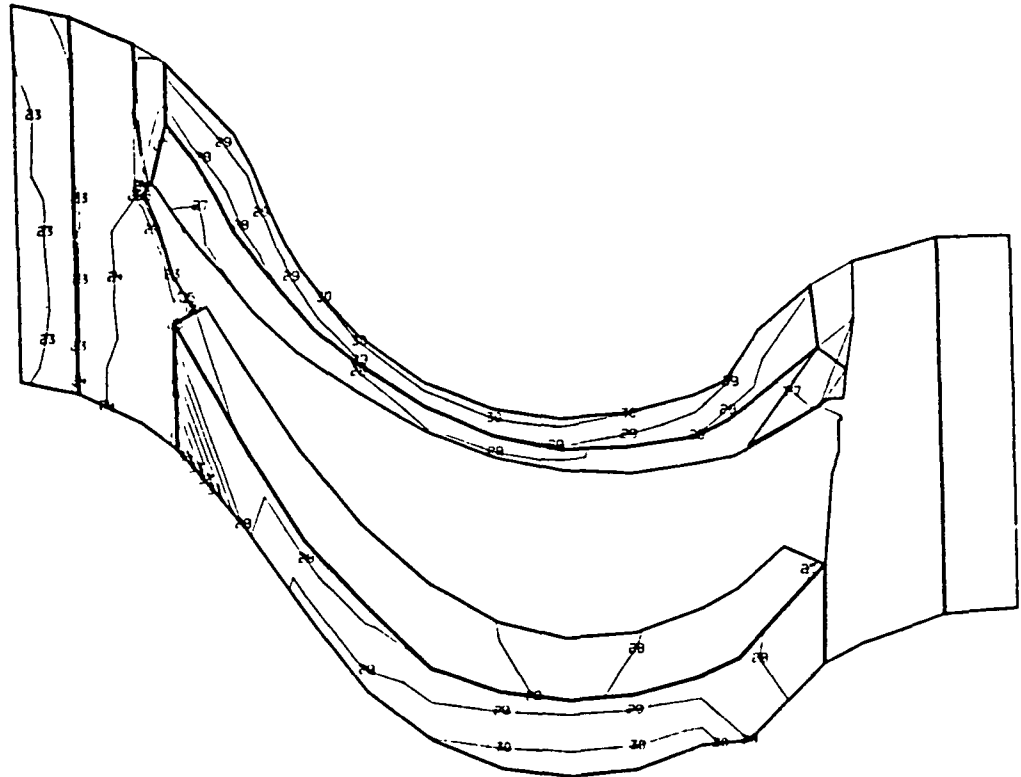

1	-3.000000E 02	14	3.500000E 02	27	1.000000E 03
2	-2.500000E 02	15	4.000000E 02	28	1.050000E 03
3	-2.000000E 02	16	4.500000E 02	29	1.100000E 03
4	-1.500000E 02	17	5.000000E 02	30	1.150000E 03
5	-1.000000E 02	18	5.500000E 02	31	1.200000E 03
6	-5.000000E 01	19	6.000000E 02	32	1.250000E 03
7	0.0	20	6.500000E 02	33	1.300000E 03
8	5.000000E 01	21	7.000000E 02	34	1.350000E 03
9	1.000000E 02	22	7.500000E 02	35	1.400000E 03
10	1.500000E 02	23	8.000000E 02	36	1.450000E 03
11	2.000000E 02	24	8.500000E 02	37	1.500000E 03
12	2.500000E 02	25	9.000000E 02	38	1.550000E 03
13	3.000000E 02	26	9.500000E 02	39	1.600000E 03

Fig. 2.3-6 Model F-2, FPL Load, View 3, Platform Bottom Steady State Surface Temperatures (F)

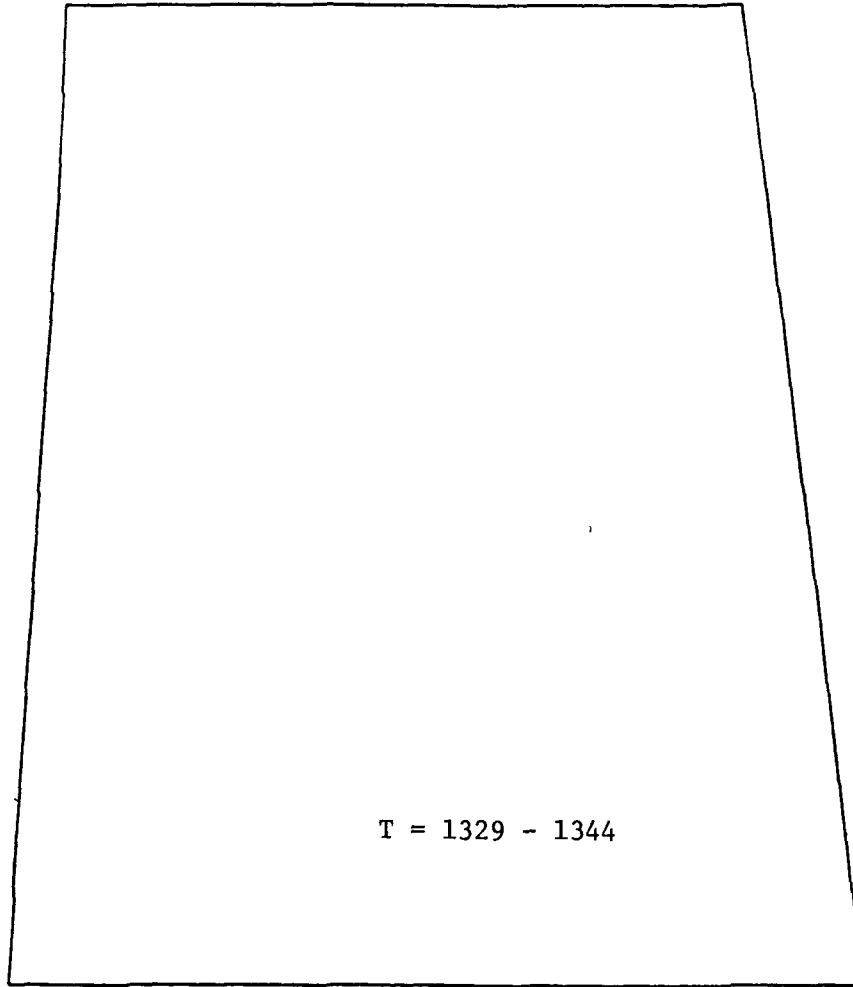

1	-3.000000E 02	14	3.500000E 02	27	1.000000E 03
2	-2.500000E 02	15	4.000000E 02	28	1.050000E 03
3	-2.000000E 02	16	4.500000E 02	29	1.100000E 03
4	-1.500000E 02	17	5.000000E 02	30	1.150000E 03
5	-1.000000E 02	18	5.500000E 02	31	1.200000E 03
6	-5.000000E 01	19	6.000000E 02	32	1.250000E 03
7	0.0	20	6.500000E 02	33	1.300000E 03
8	5.000000E 01	21	7.000000E 02	34	1.350000E 03
9	1.000000E 02	22	7.500000E 02	35	1.400000E 03
10	1.500000E 02	23	8.000000E 02	36	1.450000E 03
11	2.000000E 02	24	8.500000E 02	37	1.500000E 03
12	2.500000E 02	25	9.000000E 02	38	1.550000E 03
13	3.000000E 02	26	9.500000E 02	39	1.600000E 03

Fig. 2.3-7 Model F-2, 115% Load, View 1, Airfoil Suction Side Steady State Surface Temperatures (F)

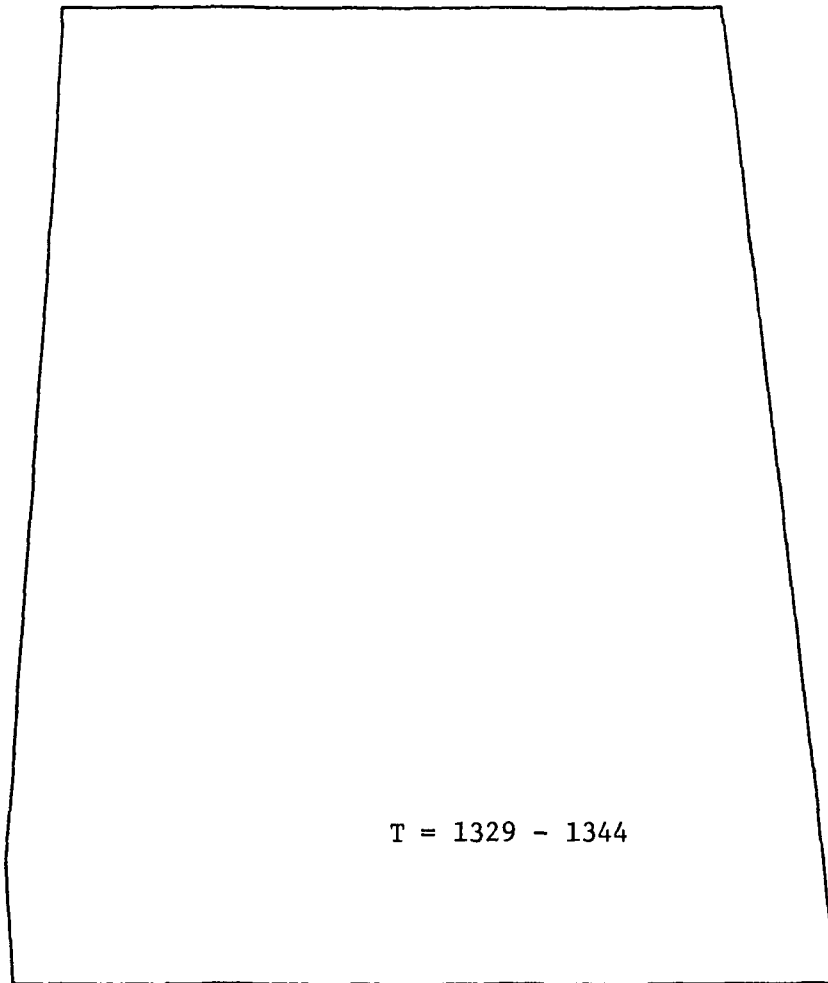

1	-3.000000E 02	14	3.500000E 02	27	1.000000E 03
2	-2.500000E 02	15	4.000000E 02	28	1.050000E 03
3	-2.000000E 02	16	4.500000E 02	29	1.100000E 03
4	-1.500000E 02	17	5.000000E 02	30	1.150000E 03
5	-1.000000E 02	18	5.500000E 02	31	1.200000E 03
6	-5.000000E 01	19	6.000000E 02	32	1.250000E 03
7	0.0	20	6.500000E 02	33	1.300000E 03
8	5.000000E 01	21	7.000000E 02	34	1.350000E 03
9	1.000000E 02	22	7.500000E 02	35	1.400000E 03
10	1.500000E 02	23	8.000000E 02	36	1.450000E 03
11	2.000000E 02	24	8.500000E 02	37	1.500000E 03
12	2.500000E 02	25	9.000000E 02	38	1.550000E 03
13	3.000000E 02	26	9.500000E 02	39	1.600000E 03

Fig. 2.3-8 Model F-2, 115% Load, View 1, Airfoil Pressure Side Steady State Surface Temperatures (F)

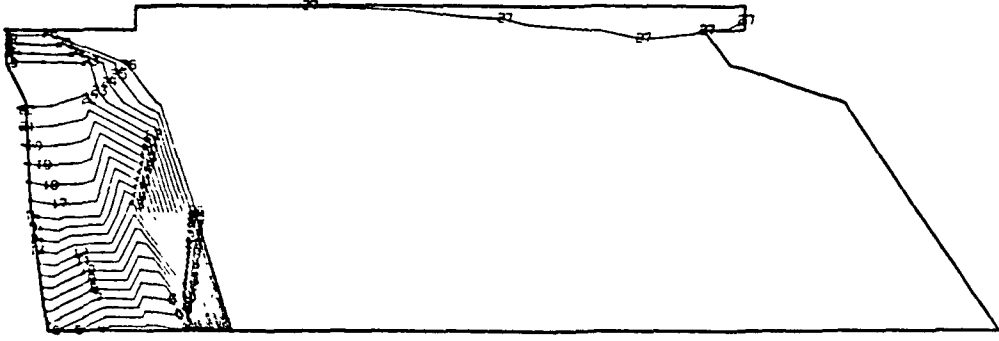

1	-3.000000E 02	14	3.500000E 02	27	1.000000E 03
2	-2.500000E 02	15	4.000000E 02	28	1.050000E 03
3	-2.000000E 02	16	4.500000E 02	29	1.100000E 03
4	-1.500000E 02	17	5.000000E 02	30	1.150000E 03
5	-1.000000E 02	18	5.500000E 02	31	1.200000E 03
6	-5.000000E 01	19	6.000000E 02	32	1.250000E 03
7	0.0	20	6.500000E 02	33	1.300000E 03
8	5.000000E 01	21	7.000000E 02	34	1.350000E 03
9	1.000000E 02	22	7.500000E 02	35	1.400000E 03
10	1.500000E 02	23	8.000000E 02	36	1.450000E 03
11	2.000000E 02	24	8.500000E 02	37	1.500000E 03
12	2.500000E 02	25	9.000000E 02	38	1.550000E 03
13	3.000000E 02	26	9.500000E 02	39	1.600000E 03

Fig. 2.3-9 Model F-2, 115% Load, View 2, Shank Suction Side Steady State Surface Temperatures (F)

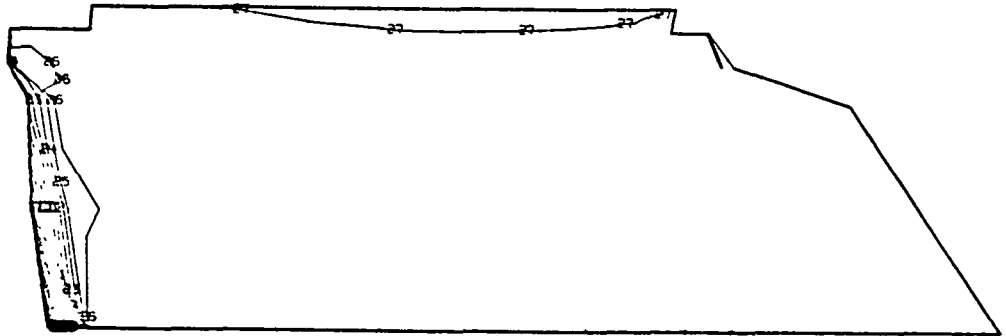

1	-3.000000E 02	14	3.500000E 02	27	1.000000E 03
2	-2.500000E 02	15	4.000000E 02	28	1.050000E 03
3	-2.000000E 02	16	4.500000E 02	29	1.100000E 03
4	-1.500000E 02	17	5.000000E 02	30	1.150000E 03
5	-1.000000E 02	18	5.500000E 02	31	1.200000E 03
6	-5.000000E 01	19	6.000000E 02	32	1.250000E 03
7	0.0	20	6.500000E 02	33	1.300000E 03
8	5.000000E 01	21	7.000000E 02	34	1.350000E 03
9	1.000000E 02	22	7.500000E 02	35	1.400000E 03
10	1.500000E 02	23	8.000000E 02	36	1.450000E 03
11	2.000000E 02	24	8.500000E 02	37	1.500000E 03
12	2.500000E 02	25	9.000000E 02	38	1.550000E 03
13	3.000000E 02	26	9.500000E 02	39	1.600000E 03

Fig. 2.3-10 Model F-2, 115% Load, View 2, Shank Pressure Side Steady State Surface Temperatures (F)

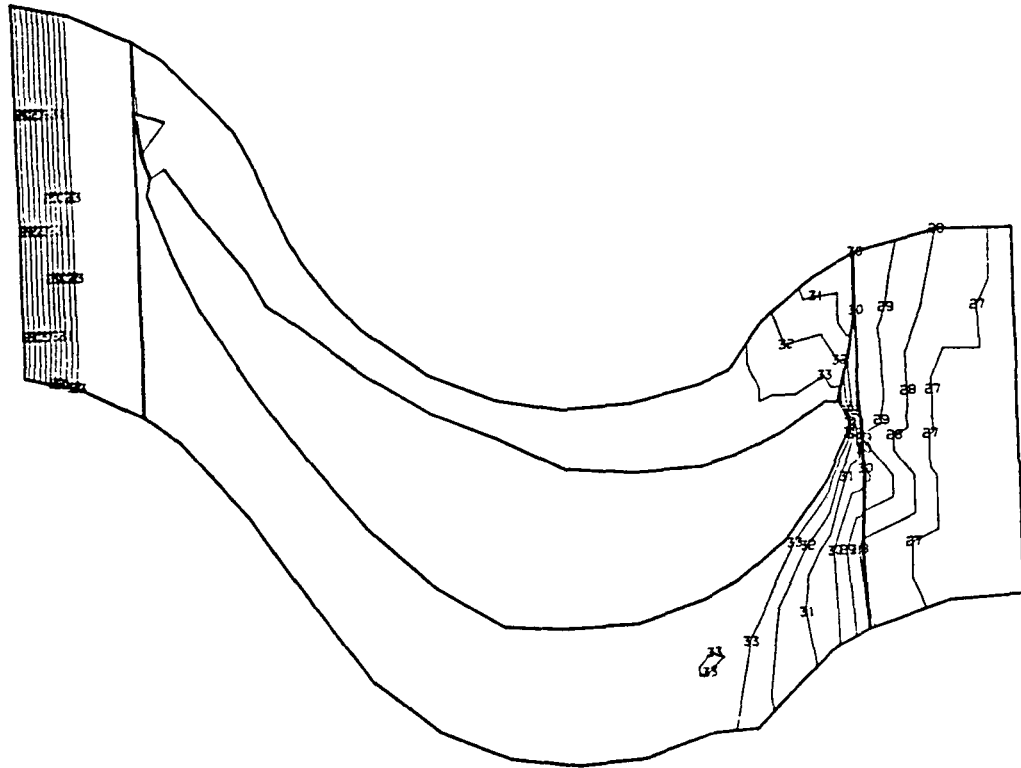

1	-3.000000E 02	14	3.500000E 02	27	1.000000E 03
2	-2.500000E 02	15	4.000000E 02	28	1.050000E 03
3	-2.000000E 02	16	4.500000E 02	29	1.100000E 03
4	-1.500000E 02	17	5.000000E 02	30	1.150000E 03
5	-1.000000E 02	18	5.500000E 02	31	1.200000E 03
6	-5.000000E 01	19	6.000000E 02	32	1.250000E 03
7	0.0	20	6.500000E 02	33	1.300000E 03
8	5.000000E 01	21	7.000000E 02	34	1.350000E 03
9	1.000000E 02	22	7.500000E 02	35	1.400000E 03
10	1.500000E 02	23	8.000000E 02	36	1.450000E 03
11	2.000000E 02	24	8.500000E 02	37	1.500000E 03
12	2.500000E 02	25	9.000000E 02	38	1.550000E 03
13	3.000000E 02	26	9.500000E 02	39	1.600000E 03

Fig. 2.3-11 Model F-2, 115% Load, View 3, Platform Top Steady State Surface Temperatures (F)

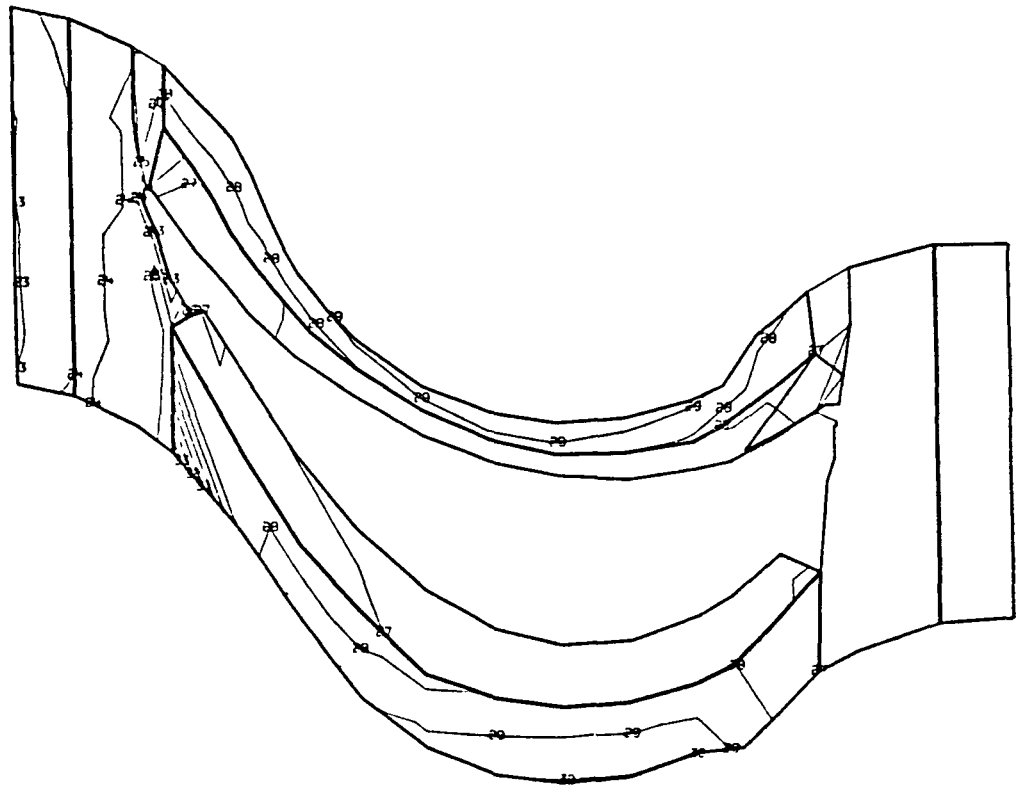

1	-3.000000E 02	14	3.500000E 02	27	1.000000E 03
2	-2.500000E 02	15	4.000000E 02	28	1.050000E 03
3	-2.000000E 02	16	4.500000E 02	29	1.100000E 03
4	-1.500000E 02	17	5.000000E 02	30	1.150000E 03
5	-1.000000E 02	18	5.500000E 02	31	1.200000E 03
6	-5.000000E 01	19	6.000000E 02	32	1.250000E 03
7	0.0	20	6.500000E 02	33	1.300000E 03
8	5.000000E 01	21	7.000000E 02	34	1.350000E 03
9	1.000000E 02	22	7.500000E 02	35	1.400000E 03
10	1.500000E 02	23	8.000000E 02	36	1.450000E 03
11	2.000000E 02	24	8.500000E 02	37	1.500000E 03
12	2.500000E 02	25	9.000000E 02	38	1.550000E 03
13	3.000000E 02	26	9.500000E 02	39	1.600000E 03

Fig. 2.3-12 Model F-2, 115% Load, View 3, Platform Bottom Steady State Surface Temperatures (F)

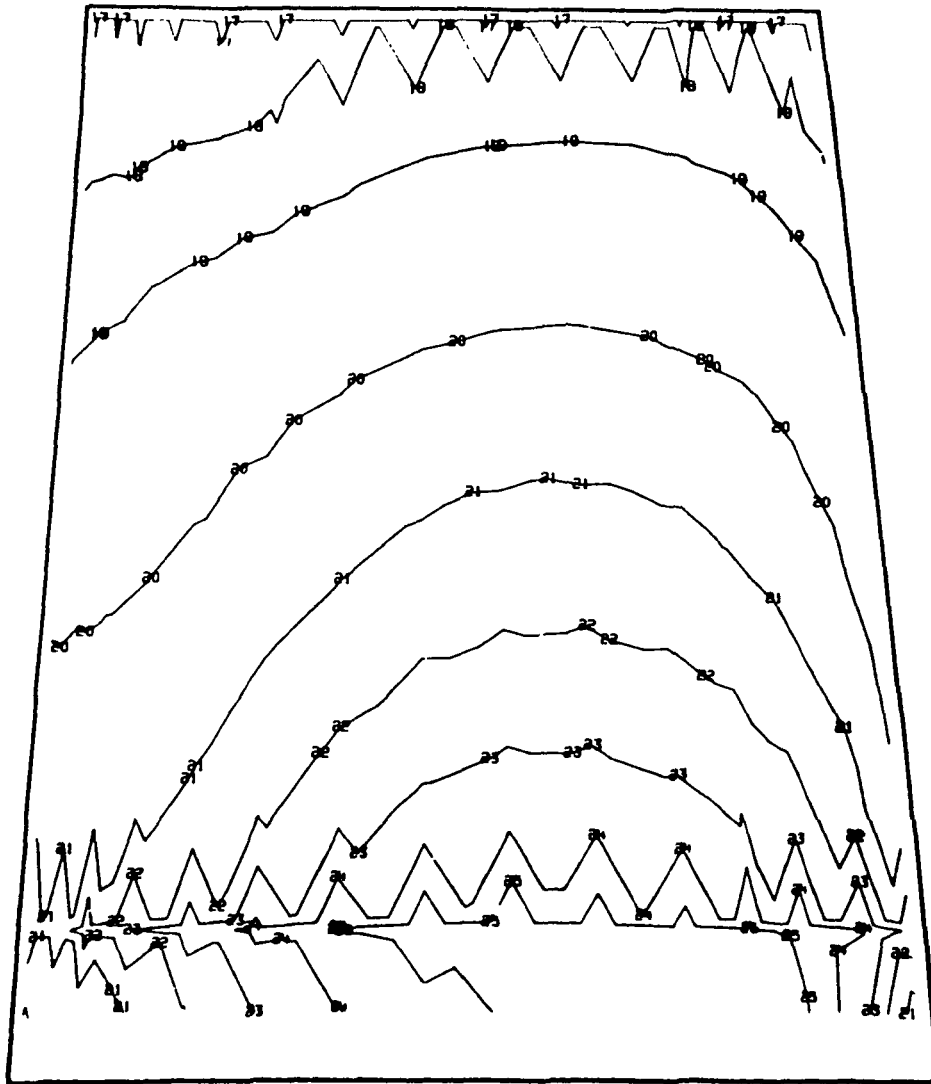

1	-1.500000E 05	12	-4.000000E 04	23	5.000000E 04
2	-1.400000E 05	13	-3.000000E 04	24	6.000000E 04
3	-1.300000E 05	14	-2.000000E 04	25	7.000000E 04
4	-1.200000E 05	15	-1.000000E 04	26	8.000000E 04
5	-1.100000E 05	16	-5.000000E 03	27	9.000000E 04
6	-1.000000E 05	17	0.0	28	1.000000E 05
7	-9.000000E 04	18	5.000000E 03	29	1.100000E 05
8	-8.000000E 04	19	1.000000E 04	30	1.200000E 05
9	-7.000000E 04	20	2.000000E 04	31	1.300000E 05
10	-6.000000E 04	21	3.000000E 04	32	1.400000E 05
11	-5.000000E 04	22	4.000000E 04	33	1.500000E 05

Fig. 2.3-13 Model F-2, FPL Load, View 1, Airfoil Suction Side Major Principal Stress (psi)

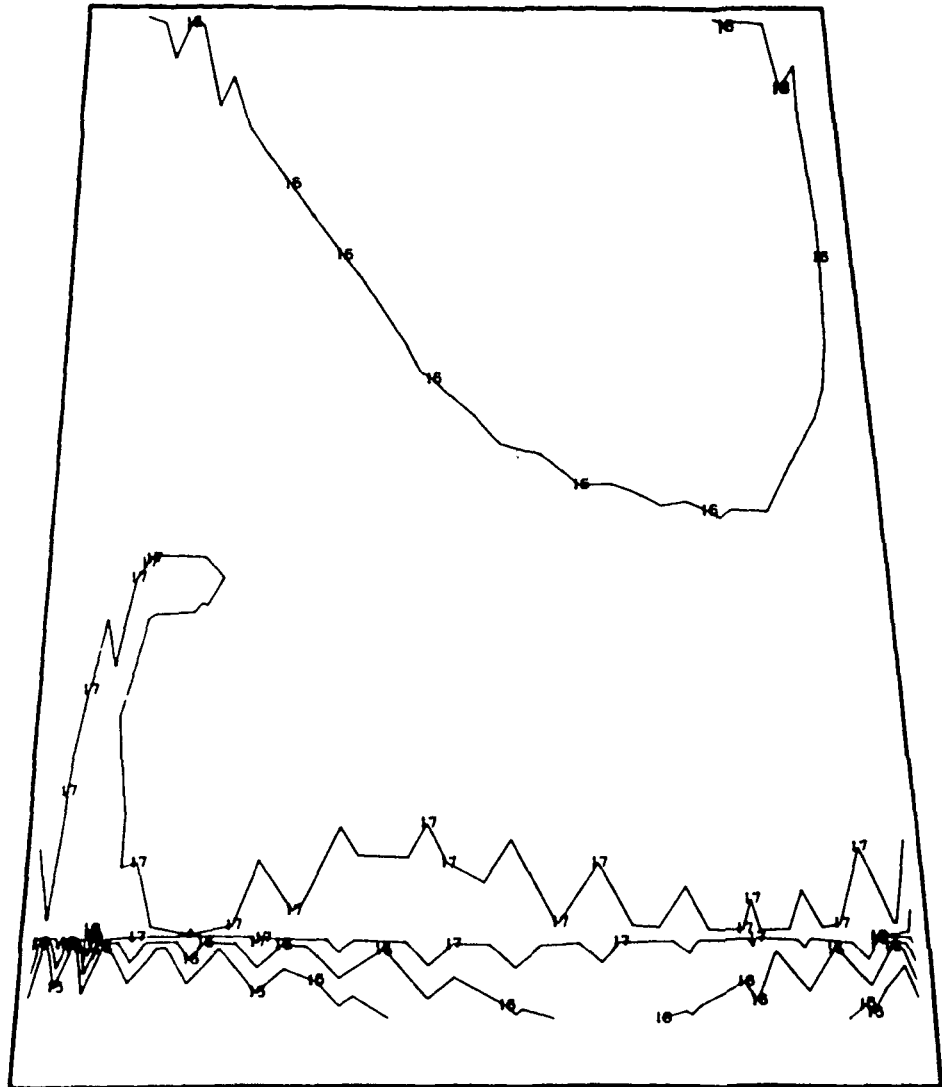

1	-1.500000E 05	12	-4.000000E 04	23	5.000000E 04
2	-1.400000E 05	13	-3.000000E 04	24	6.000000E 04
3	-1.300000E 05	14	-2.000000E 04	25	7.000000E 04
4	-1.200000E 05	15	-1.000000E 04	26	8.000000E 04
5	-1.100000E 05	16	-5.000000E 03	27	9.000000E 04
6	-1.000000E 05	17	0.0	28	1.000000E 05
7	-9.000000E 04	18	5.000000E 03	29	1.100000E 05
8	-8.000000E 04	19	1.000000E 04	30	1.200000E 05
9	-7.000000E 04	20	2.000000E 04	31	1.300000E 05
10	-6.000000E 04	21	3.000000E 04	32	1.400000E 05
11	-5.000000E 04	22	4.000000E 04	33	1.500000E 05

Fig. 2.3-14 Model F-2, FPL Load, View 1, Airfoil Suction Side Major Principal Stress (psi)

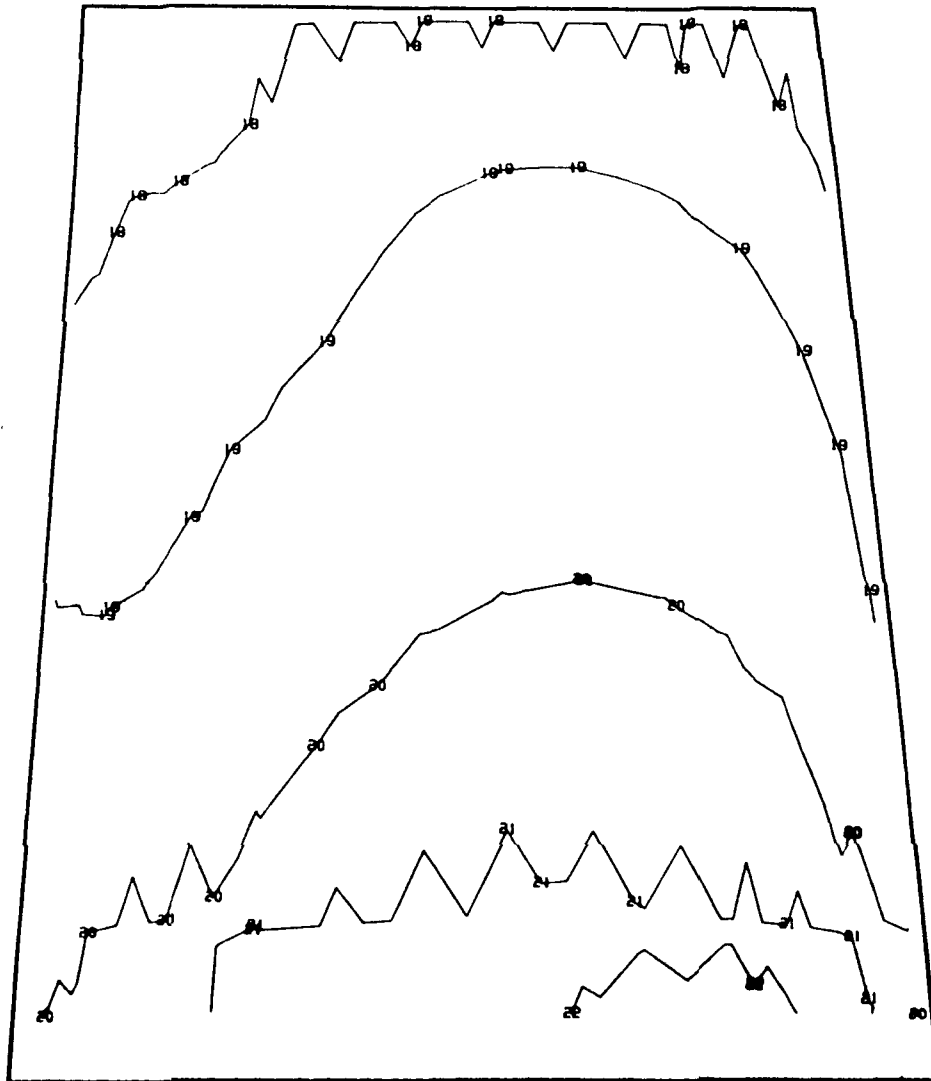

1	-1.500000E 05	12	-4.000000E 04	23	5.000000E 04
2	-1.400000E 05	13	-3.000000E 04	24	6.000000E 04
3	-1.300000E 05	14	-2.000000E 04	25	7.000000E 04
4	-1.200000E 05	15	-1.000000E 04	26	8.000000E 04
5	-1.100000E 05	16	-5.000000E 03	27	9.000000E 04
6	-1.000000E 05	17	0.0	28	1.000000E 05
7	-9.000000E 04	18	5.000000E 03	29	1.100000E 05
8	-8.000000E 04	19	1.000000E 04	30	1.200000E 05
9	-7.000000E 04	20	2.000000E 04	31	1.300000E 05
10	-6.000000E 04	21	3.000000E 04	32	1.400000E 05
11	-5.000000E 04	22	4.000000E 04	33	1.500000E 05

Fig. 2.3-15 Model F-2, FPL Load, View 1, Airfoil Suction Side Maximum Principal Shear (psi)

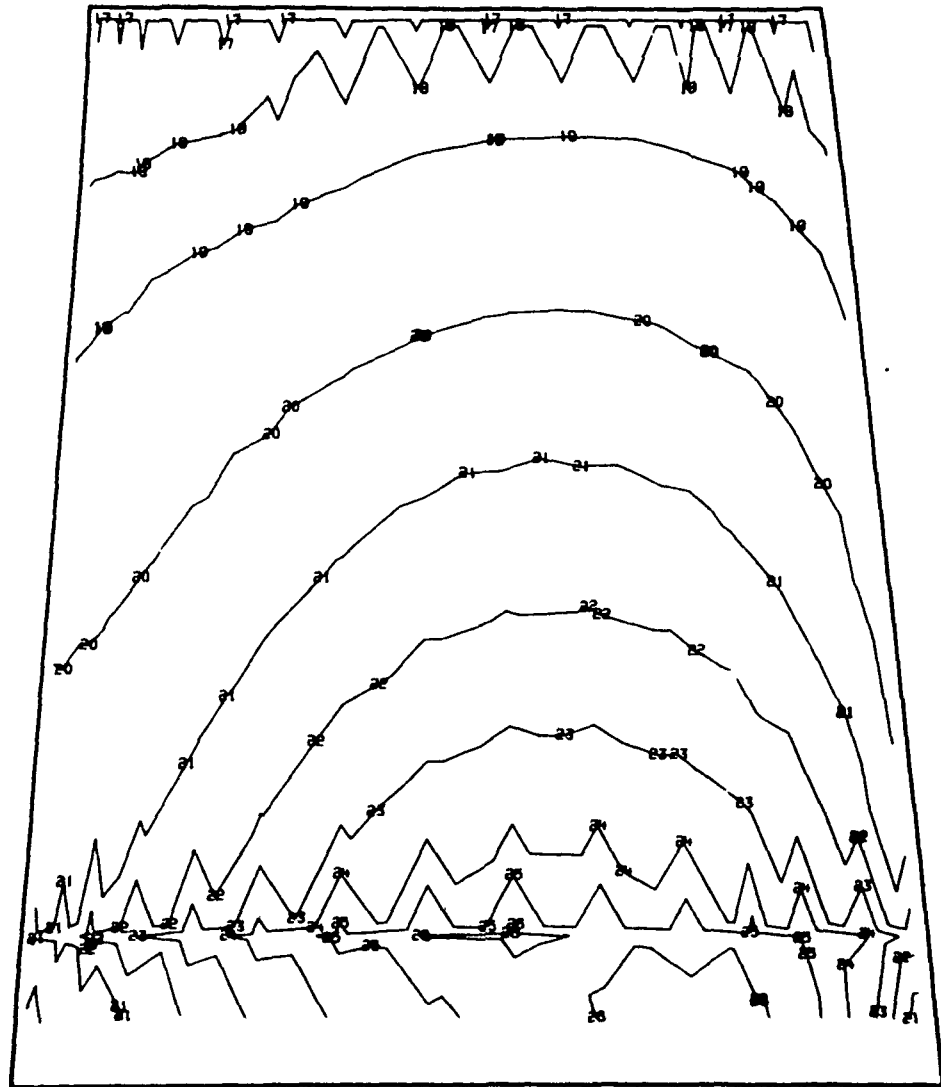

1	-1.500000E 05	05	12	-4.000000E 04	04	23	5.000000E 04	04
2	-1.400000E 05	05	13	-3.000000E 04	04	24	6.000000E 04	04
3	-1.300000E 05	05	14	-2.000000E 04	04	25	7.000000E 04	04
4	-1.200000E 05	05	15	-1.000000E 04	04	26	8.000000E 04	04
5	-1.100000E 05	05	16	-5.000000E 03	03	27	9.000000E 04	04
6	-1.000000E 05	05	17	0.0		28	1.000000E 05	05
7	-9.000000E 04	04	18	5.000000E 03	03	29	1.100000E 05	05
8	-8.000000E 04	04	19	1.000000E 04	04	30	1.200000E 05	05
9	-7.000000E 04	04	20	2.000000E 04	04	31	1.300000E 05	05
10	-6.000000E 04	04	21	3.000000E 04	04	32	1.400000E 05	05
11	-5.000000E 04	04	22	4.000000E 04	04	33	1.500000E 05	05

Fig. 2.3-16 Model F-2, 115% Load, View 1, Airfoil Suction Side Major Principal Stress (psi)

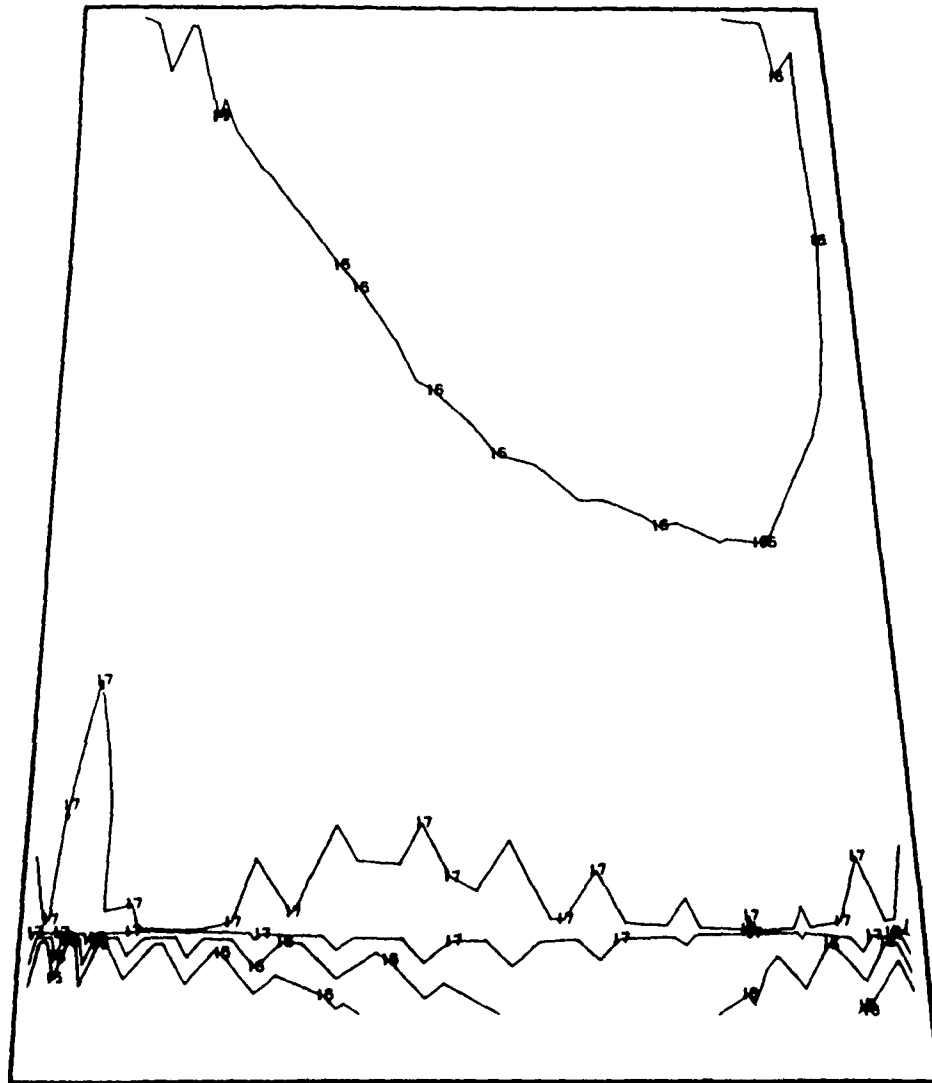

1	-1.500000E 05	12	-4.000000E 04	23	5.000000E 04
2	-1.400000E 05	13	-3.000000E 04	24	6.000000E 04
3	-1.300000E 05	14	-2.000000E 04	25	7.000000E 04
4	-1.200000E 05	15	-1.000000E 04	26	8.000000E 04
5	-1.100000E 05	16	-5.000000E 03	27	9.000000E 04
6	-1.000000E 05	17	0.0	28	1.000000E 05
7	-9.000000E 04	18	5.000000E 03	29	1.100000E 05
8	-8.000000E 04	19	1.000000E 04	30	1.200000E 05
9	-7.000000E 04	20	2.000000E 04	31	1.300000E 05
10	-6.000000E 04	21	3.000000E 04	32	1.400000E 05
11	-5.000000E 04	22	4.000000E 04	33	1.500000E 05

Fig. 2.3-17 Model F-2, 115% Load, View 1, Airfoil Suction Side Minor Principal Stress (psi)

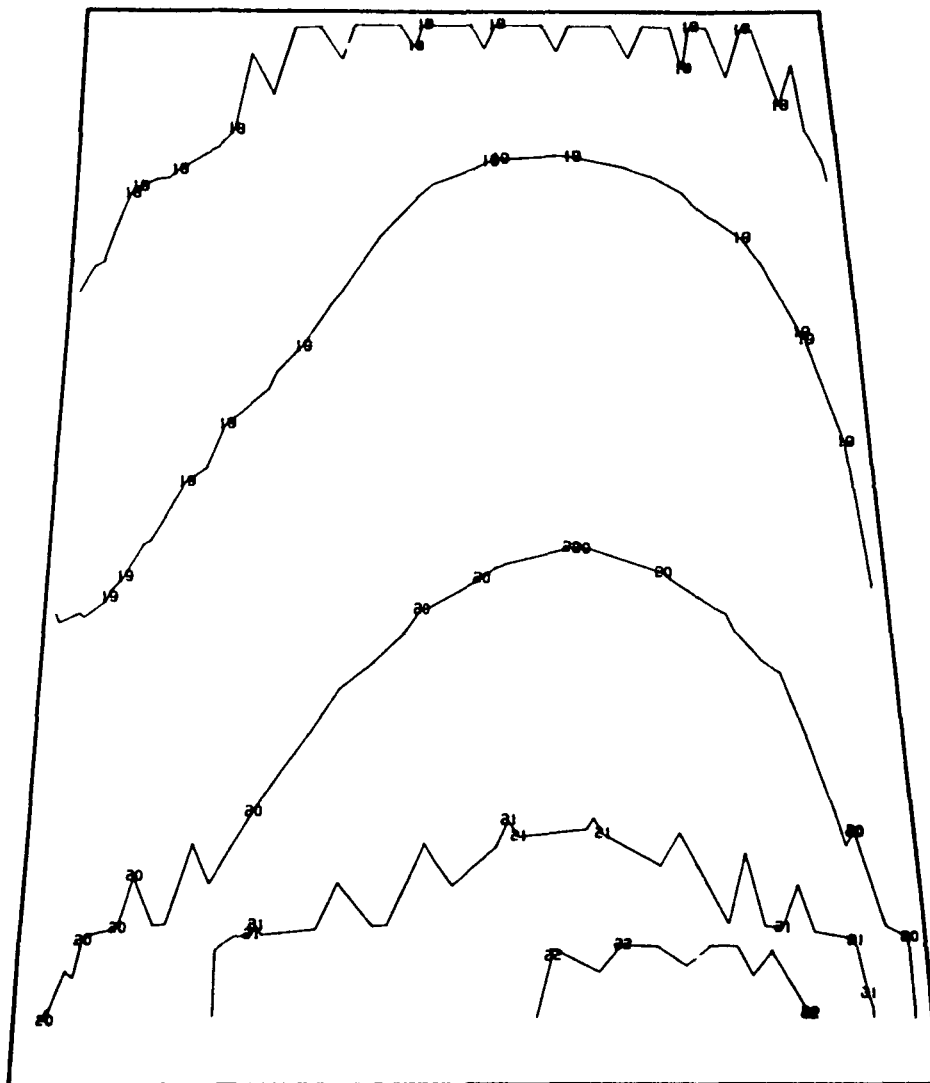

1	-1.500000E 05	12	-4.000000E 04	23	5.000000E 04
2	-1.400000E 05	13	-3.000000E 04	24	6.000000E 04
3	-1.300000E 05	14	-2.000000E 04	25	7.000000E 04
4	-1.200000E 05	15	-1.000000E 04	26	8.000000E 04
5	-1.100000E 05	16	-5.000000E 03	27	9.000000E 04
6	-1.000000E 05	17	0.0	28	1.000000E 05
7	-9.000000E 04	18	5.000000E 03	29	1.100000E 05
8	-8.000000E 04	19	1.000000E 04	30	1.200000E 05
9	-7.000000E 04	20	2.000000E 04	31	1.300000E 05
10	-6.000000E 04	21	3.000000E 04	32	1.400000E 05
11	-5.000000E 04	22	4.000000E 04	33	1.500000E 05

Fig. 2.3-18 Model F-2, 115% Load, View 1, Airfoil Suction Side Maximum Principal Shear (psi)

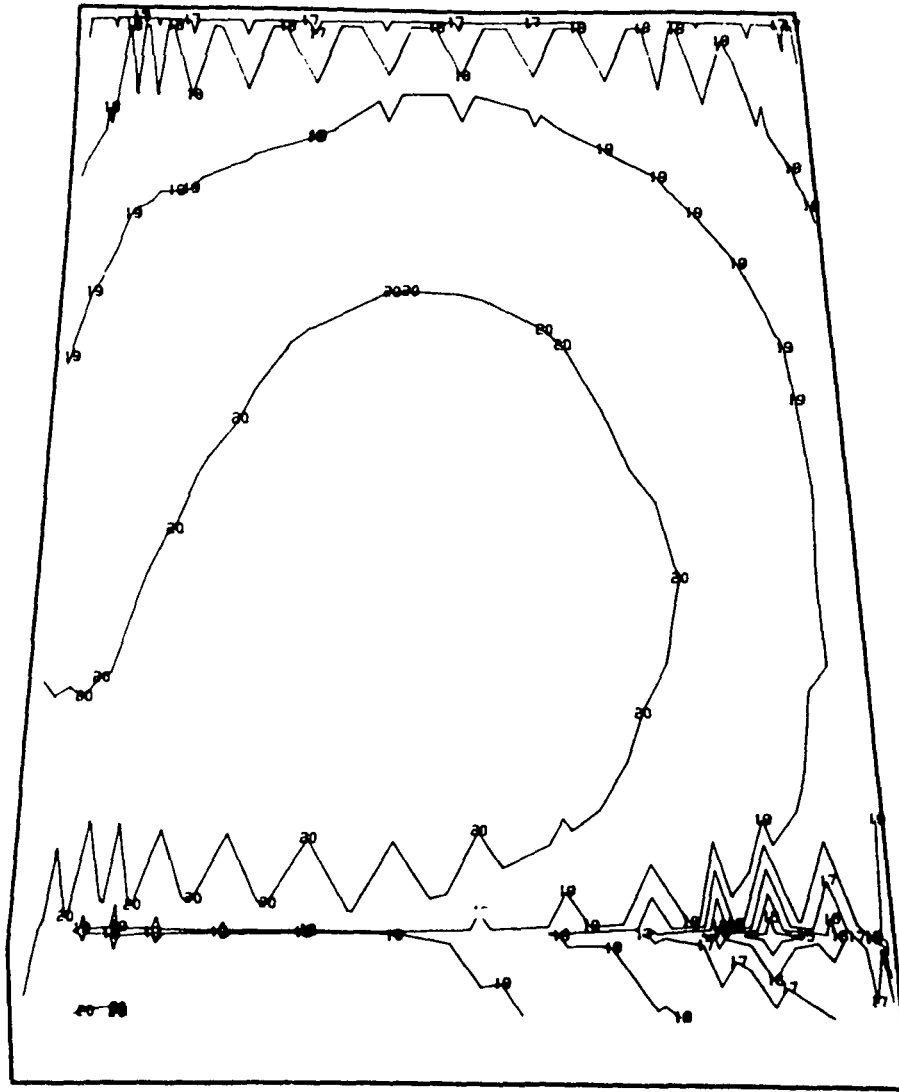

1	-1.500000E 05	12	-4.000000E 04	23	5.000000E 04
2	-1.400000E 05	13	-3.000000E 04	24	6.000000E 04
3	-1.300000E 05	14	-2.000000E 04	25	7.000000E 04
4	-1.200000E 05	15	-1.000000E 04	26	8.000000E 04
5	-1.100000E 05	16	-5.000000E 03	27	9.000000E 04
6	-1.000000E 05	17	0.0	28	1.000000E 05
7	-9.000000E 04	18	5.000000E 03	29	1.100000E 05
8	-8.000000E 04	19	1.000000E 04	30	1.200000E 05
9	-7.000000E 04	20	2.000000E 04	31	1.300000E 05
10	-6.000000E 04	21	3.000000E 04	32	1.400000E 05
11	-5.000000E 04	22	4.000000E 04	33	1.500000E 05

Fig. 2.3-19 Model F-2, FPL Load, View 1, Airfoil Pressure Side Major Principal Stress (psi)

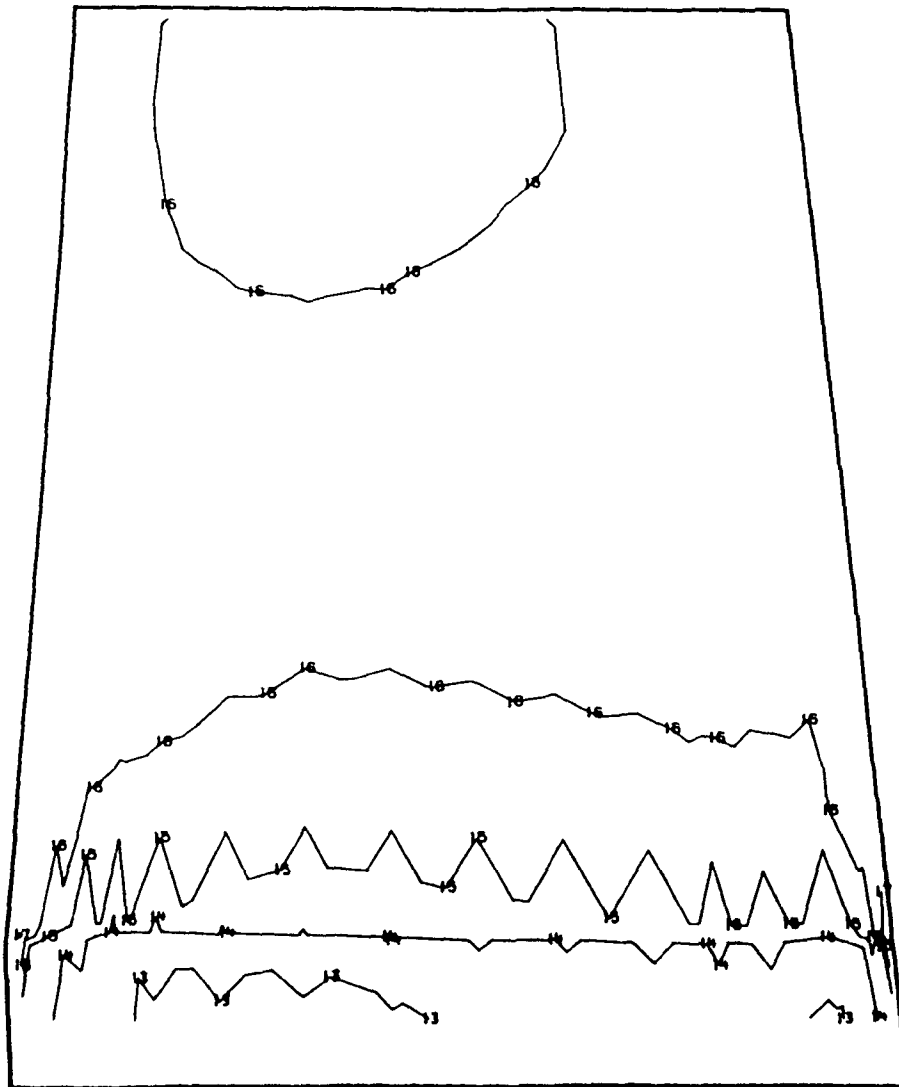

1	-1.500000E 05	12	-4.000000E 04	23	5.000000E 04
2	-1.400000E 05	13	-3.000000E 04	24	6.000000E 04
3	-1.300000E 05	14	-2.000000E 04	25	7.000000E 04
4	-1.200000E 05	15	-1.000000E 04	26	8.000000E 04
5	-1.100000E 05	16	-5.000000E 03	27	9.000000E 04
6	-1.000000E 05	17	0.0	28	1.000000E 05
7	-9.000000E 04	18	5.000000E 03	29	1.100000E 05
8	-8.000000E 04	19	1.000000E 04	30	1.200000E 05
9	-7.000000E 04	20	2.000000E 04	31	1.300000E 05
10	-6.000000E 04	21	3.000000E 04	32	1.400000E 05
11	-5.000000E 04	22	4.000000E 04	33	1.500000E 05

Fig. 2.3-20 Model F-2, FPL Load, View 1, Airfoil Pressure Side Minor Principal Stress (psi)

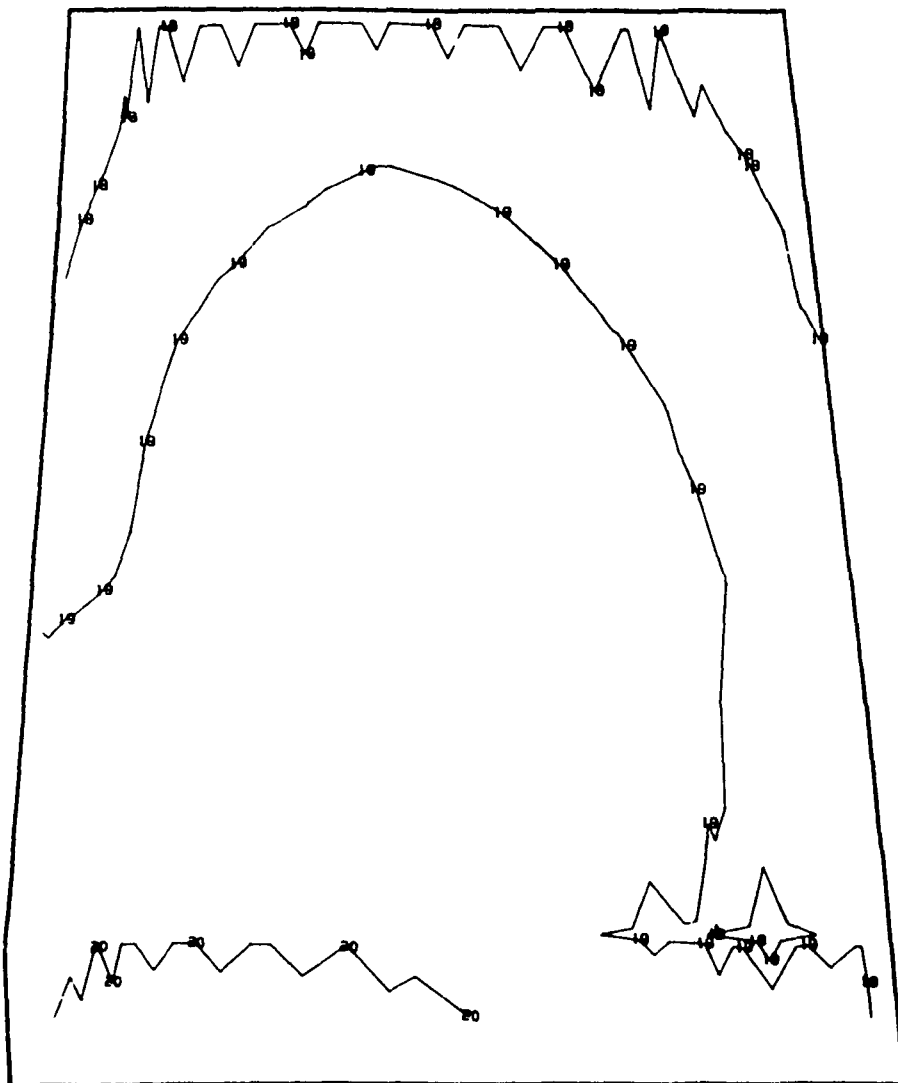

1	-1.500000E 05	12	-4.000000E 04	23	5.000000E 04
2	-1.400000E 05	13	-3.000000E 04	24	6.000000E 04
3	-1.300000E 05	14	-2.000000E 04	25	7.000000E 04
4	-1.200000E 05	15	-1.000000E 04	26	8.000000E 04
5	-1.100000E 05	16	-5.000000E 03	27	9.000000E 04
6	-1.000000E 05	17	0.0	28	1.000000E 05
7	-9.000000E 04	18	5.000000E 03	29	1.100000E 05
8	-8.000000E 04	19	1.000000E 04	30	1.200000E 05
9	-7.000000E 04	20	2.000000E 04	31	1.300000E 05
10	-6.000000E 04	21	3.000000E 04	32	1.400000E 05
11	-5.000000E 04	22	4.000000E 04	33	1.500000E 05

Fig. 2.3-21 Model F-2, FPL Load, View 1, Airfoil Pressure Side Maximum Principal Shear (psi)

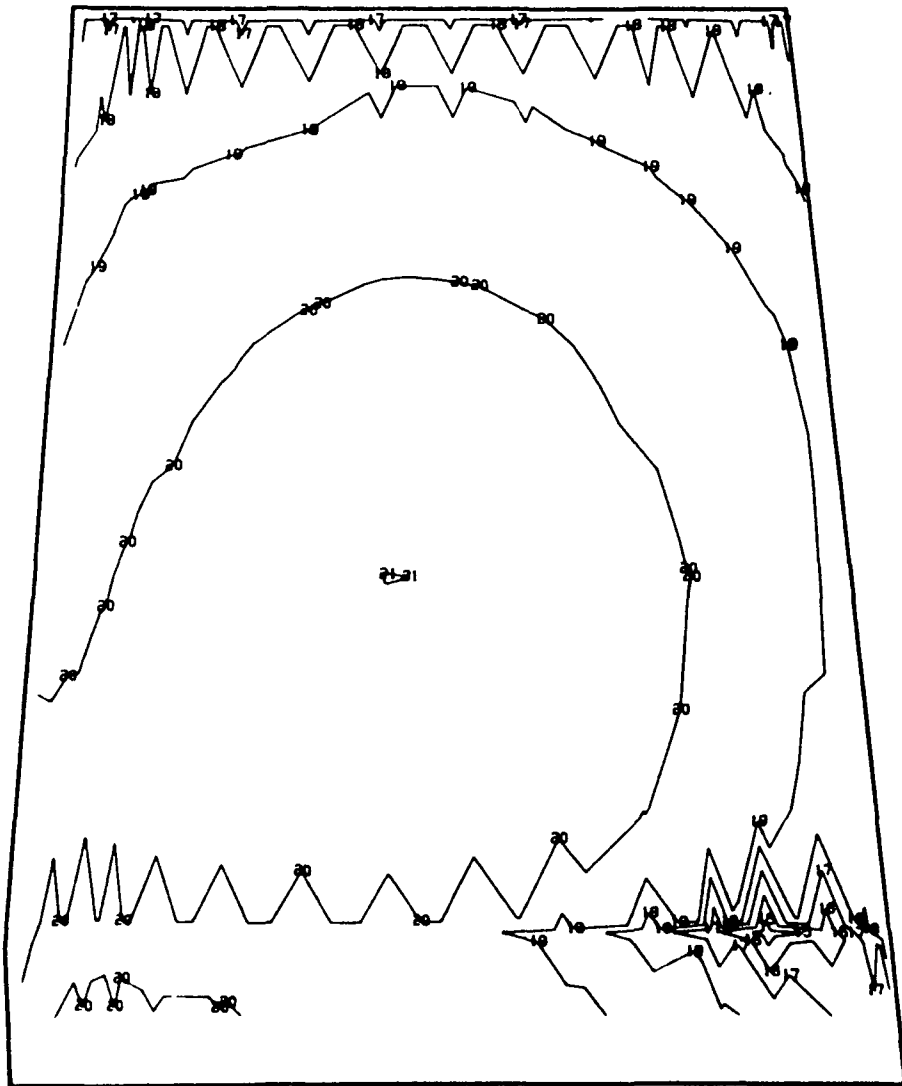

1	-1.500000E 05	12	-4.000000E 04	23	5.000000E 04
2	-1.400000E 05	13	-3.000000E 04	24	6.000000E 04
3	-1.300000E 05	14	-2.000000E 04	25	7.000000E 04
4	-1.200000E 05	15	-1.000000E 04	26	8.000000E 04
5	-1.100000E 05	16	-5.000000E 03	27	9.000000E 04
6	-1.000000E 05	17	0.0	28	1.000000E 05
7	-9.000000E 04	18	5.000000E 03	29	1.100000E 05
8	-8.000000E 04	19	1.000000E 04	30	1.200000E 05
9	-7.000000E 04	20	2.000000E 04	31	1.300000E 05
10	-6.000000E 04	21	3.000000E 04	32	1.400000E 05
11	-5.000000E 04	22	4.000000E 04	33	1.500000E 05

Fig. 2.3-22 Model F-2, 115% Load, View 1, Airfoil Pressure Side Major Principal Stress (psi)

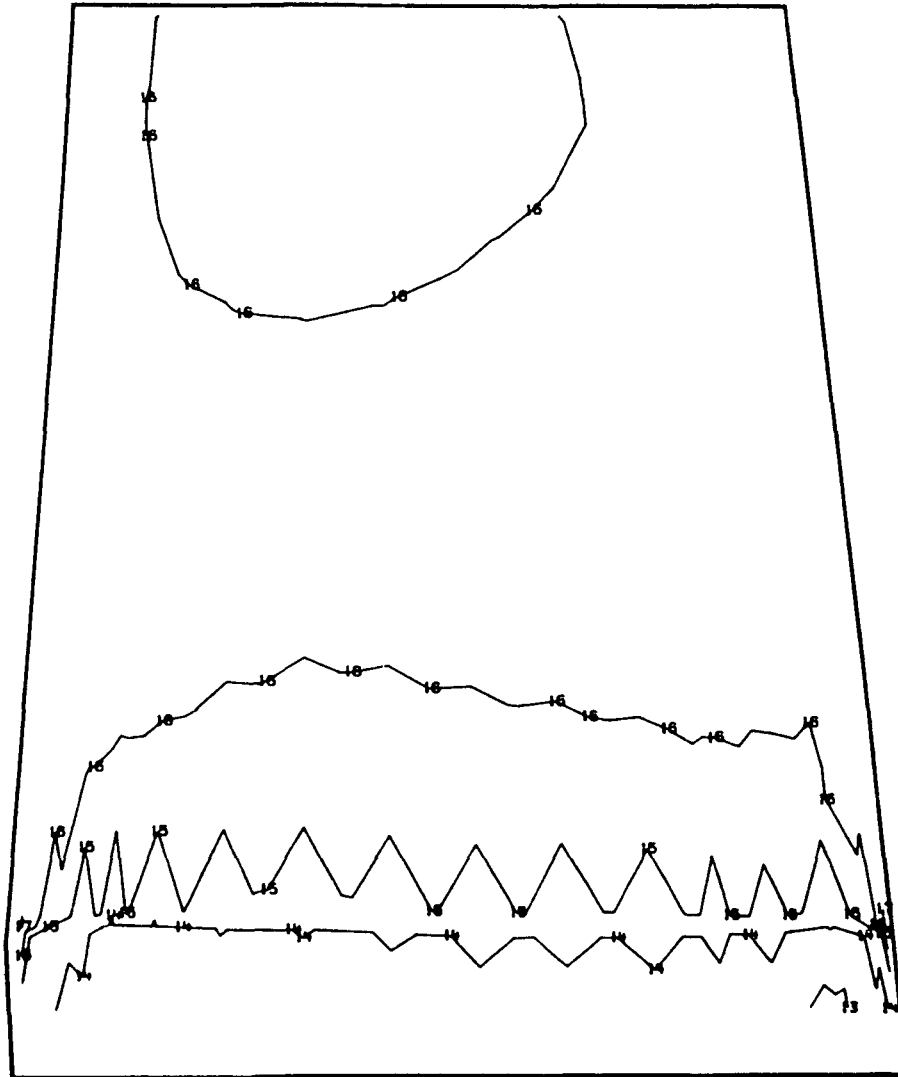

1	-1.500000E 05	12	-4.000000E 04	23	5.000000E 04
2	-1.400000E 05	13	-3.000000E 04	24	6.000000E 04
3	-1.300000E 05	14	-2.000000E 04	25	7.000000E 04
4	-1.200000E 05	15	-1.000000E 04	26	8.000000E 04
5	-1.100000E 05	16	-5.000000E 03	27	9.000000E 04
6	-1.000000E 05	17	0.0	28	1.000000E 05
7	-9.000000E 04	18	5.000000E 03	29	1.100000E 05
8	-8.000000E 04	19	1.000000E 04	30	1.200000E 05
9	-7.000000E 04	20	2.000000E 04	31	1.300000E 05
10	-6.000000E 04	21	3.000000E 04	32	1.400000E 05
11	-5.000000E 04	22	4.000000E 04	33	1.500000E 05

Fig. 2.3-23 Model F-2, 115% Load, View 1, Airfoil Pressure Side Minor Principal Stress (psi)

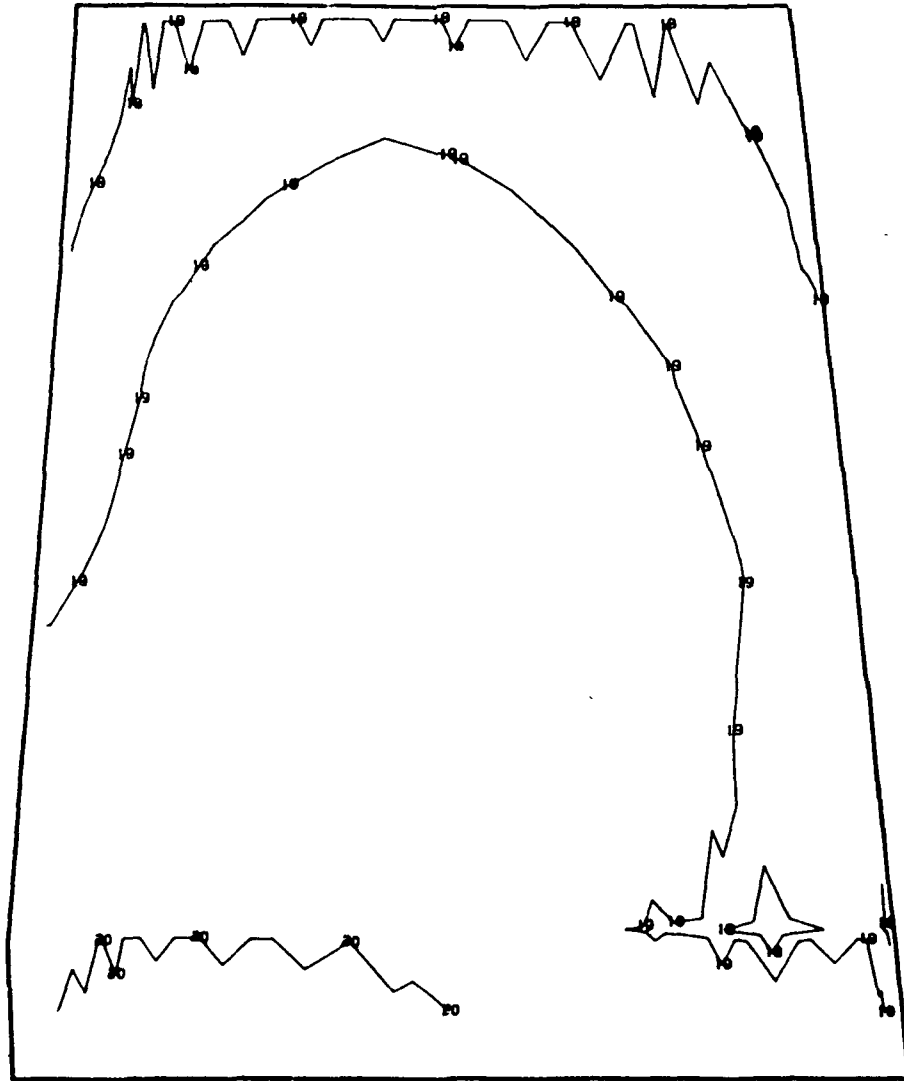

1	-1.500000E 05	12	-4.000000E 04	23	5.000000E 04
2	-1.400000E 05	13	-3.000000E 04	24	6.000000E 04
3	-1.300000E 05	14	-2.000000E 04	25	7.000000E 04
4	-1.200000E 05	15	-1.000000E 04	26	8.000000E 04
5	-1.100000E 05	16	-5.000000E 03	27	9.000000E 04
6	-1.000000E 05	17	0.0	28	1.000000E 05
7	-9.000000E 04	18	5.000000E 03	29	1.100000E 05
8	-8.000000E 04	19	1.000000E 04	30	1.200000E 05
9	-7.000000E 04	20	2.000000E 04	31	1.300000E 05
10	-6.000000E 04	21	3.000000E 04	32	1.400000E 05
11	-5.000000E 04	22	4.000000E 04	33	1.500000E 05

Fig. 2.3-24 Model F-2, 115% Load, View 1, Airfoil Pressure Side Maximum Principal Shear (psi)

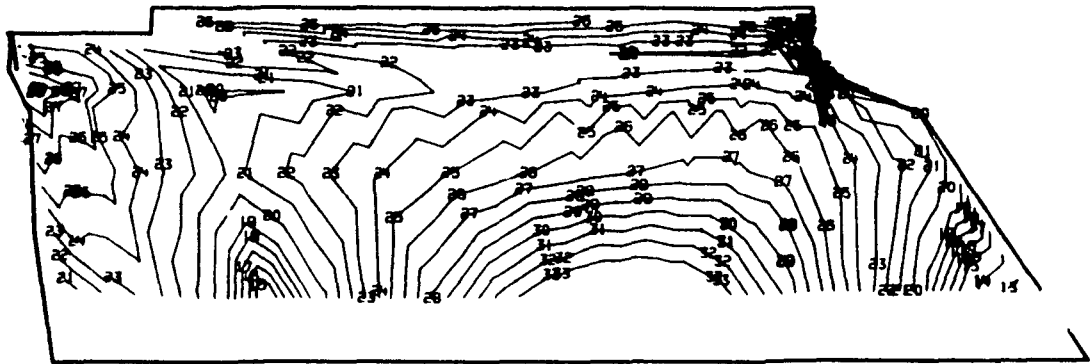

1	-1.500000E 05	12	-4.000000E 04	23	5.000000E 04
2	-1.400000E 05	13	-3.000000E 04	24	6.000000E 04
3	-1.300000E 05	14	-2.000000E 04	25	7.000000E 04
4	-1.200000E 05	15	-1.000000E 04	26	8.000000E 04
5	-1.100000E 05	16	-5.000000E 03	27	9.000000E 04
6	-1.000000E 05	17	0.0	28	1.000000E 05
7	-9.000000E 04	18	5.000000E 03	29	1.100000E 05
8	-8.000000E 04	19	1.000000E 04	30	1.200000E 05
9	-7.000000E 04	20	2.000000E 04	31	1.300000E 05
10	-6.000000E 04	21	3.000000E 04	32	1.400000E 05
11	-5.000000E 04	22	4.000000E 04	33	1.500000E 05

Fig. 2.3-25 Model F-2, FPL Load, View 2, Shank Suction Side Major Principal Stress (psi)

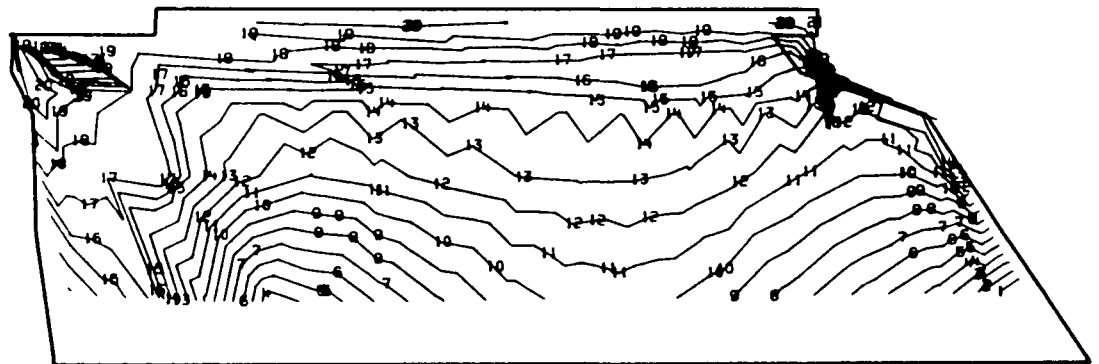

1	-1.500000E 05	12	-4.000000E 04	23	5.000000E 04
2	-1.400000E 05	13	-3.000000E 04	24	6.000000E 04
3	-1.300000E 05	14	-2.000000E 04	25	7.000000E 04
4	-1.200000E 05	15	-1.000000E 04	26	8.000000E 04
5	-1.100000E 05	16	-5.000000E 03	27	9.000000E 04
6	-1.000000E 05	17	0.0	28	1.000000E 05
7	-9.000000E 04	18	5.000000E 03	29	1.100000E 05
8	-8.000000E 04	19	1.000000E 04	30	1.200000E 05
9	-7.000000E 04	20	2.000000E 04	31	1.300000E 05
10	-6.000000E 04	21	3.000000E 04	32	1.400000E 05
11	-5.000000E 04	22	4.000000E 04	33	1.500000E 05

Fig. 2.3-26 Model F-2, FPL Load, View 2, Shank Suction Side Minor Principal Stress (psi)

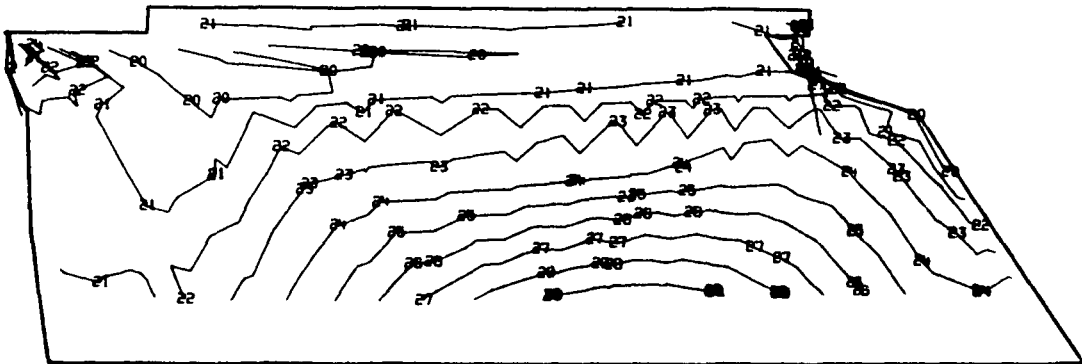

1	-1.500000E 05	12	-4.000000E 04	23	5.000000E 04
2	-1.400000E 05	13	-3.000000E 04	24	6.000000E 04
3	-1.300000E 05	14	-2.000000E 04	25	7.000000E 04
4	-1.200000E 05	15	-1.000000E 04	26	8.000000E 04
5	-1.100000E 05	16	-5.000000E 03	27	9.000000E 04
6	-1.000000E 05	17	0.0	28	1.000000E 05
7	-9.000000E 04	18	5.000000E 03	29	1.100000E 05
8	-8.000000E 04	19	1.000000E 04	30	1.200000E 05
9	-7.000000E 04	20	2.000000E 04	31	1.300000E 05
10	-6.000000E 04	21	3.000000E 04	32	1.400000E 05
11	-5.000000E 04	22	4.000000E 04	33	1.500000E 05

Fig. 2.3-27 Model F-2, FPL Load, View 2, Shank Suction Side Maximum Principal Shear (psi)

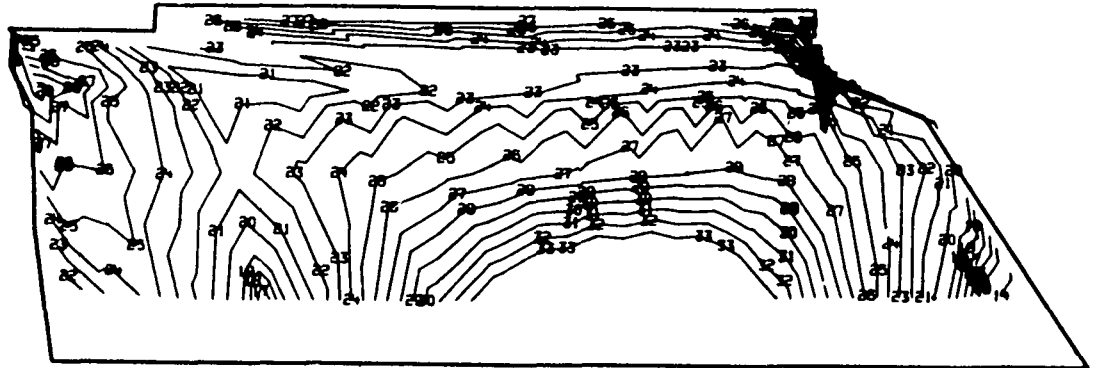

1	-1.500000E 05	12	-4.000000E 04	23	5.000000E 04
2	-1.400000E 05	13	-3.000000E 04	24	6.000000E 04
3	-1.300000E 05	14	-2.000000E 04	25	7.000000E 04
4	-1.200000E 05	15	-1.000000E 04	26	8.000000E 04
5	-1.100000E 05	16	-5.000000E 03	27	9.000000E 04
6	-1.000000E 05	17	0.0	28	1.000000E 05
7	-9.000000E 04	18	5.000000E 03	29	1.100000E 05
8	-8.000000E 04	19	1.000000E 04	30	1.200000E 05
9	-7.000000E 04	20	2.000000E 04	31	1.300000E 05
10	-6.000000E 04	21	3.000000E 04	32	1.400000E 05
11	-5.000000E 04	22	4.000000E 04	33	1.500000E 05

Fig. 2.3-28 Model F-2, 115% Load, View 2, Shank Suction Side Major Principal Stress (psi)

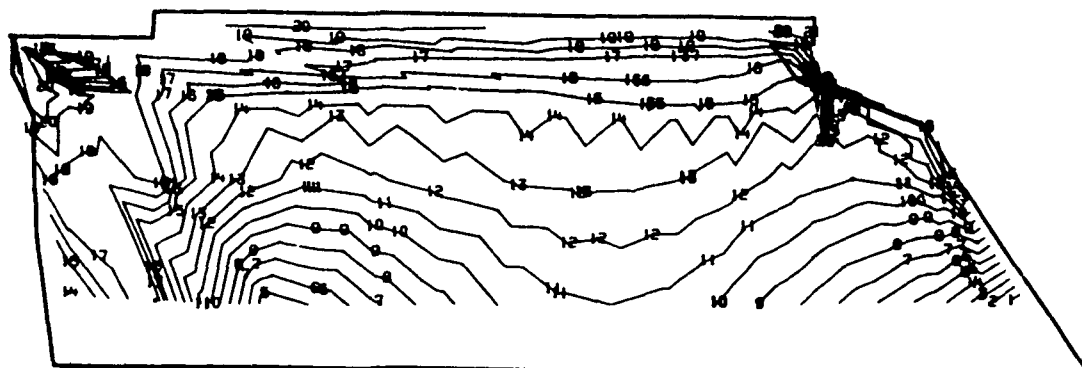

1	-1.500000E 05	12	-4.000000E 04	23	5.000000E 04
2	-1.400000E 05	13	-3.000000E 04	24	6.000000E 04
3	-1.300000E 05	14	-2.000000E 04	25	7.000000E 04
4	-1.200000E 05	15	-1.000000E 04	26	8.000000E 04
5	-1.100000E 05	16	-5.000000E 03	27	9.000000E 04
6	-1.000000E 05	17	0.0	28	1.000000E 05
7	-9.000000E 04	18	5.000000E 03	29	1.100000E 05
8	-8.000000E 04	19	1.000000E 04	30	1.200000E 05
9	-7.000000E 04	20	2.000000E 04	31	1.300000E 05
10	-6.000000E 04	21	3.000000E 04	32	1.400000E 05
11	-5.000000E 04	22	4.000000E 04	33	1.500000E 05

Fig. 2.3-29 Model F-2, 115% Load, View 2, Shank Suction Side Major Principal Stress (psi)

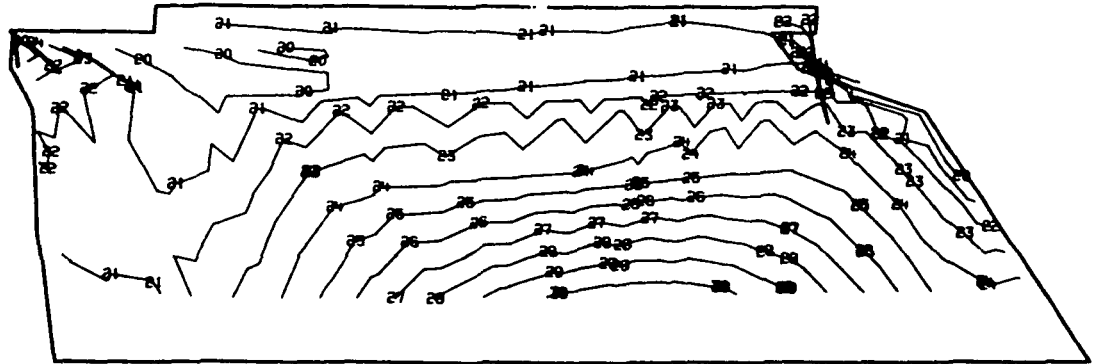

1	-1.500000E 05	12	-4.000000E 04	23	5.000000E 04
2	-1.400000E 05	13	-3.000000E 04	24	6.000000E 04
3	-1.300000E 05	14	-2.000000E 04	25	7.000000E 04
4	-1.200000E 05	15	-1.000000E 04	26	8.000000E 04
5	-1.100000E 05	16	-5.000000E 03	27	9.000000E 04
6	-1.000000E 05	17	0.0	28	1.000000E 05
7	-9.000000E 04	18	5.000000E 03	29	1.100000E 05
8	-8.000000E 04	19	1.000000E 04	30	1.200000E 05
9	-7.000000E 04	20	2.000000E 04	31	1.300000E 05
10	-6.000000E 04	21	3.000000E 04	32	1.400000E 05
11	-5.000000E 04	22	4.000000E 04	33	1.500000E 05

Fig. 2.3-30 Model F-2, 115% Load, View 2, Shank Suction Side Maximum Principal Shear (psi)

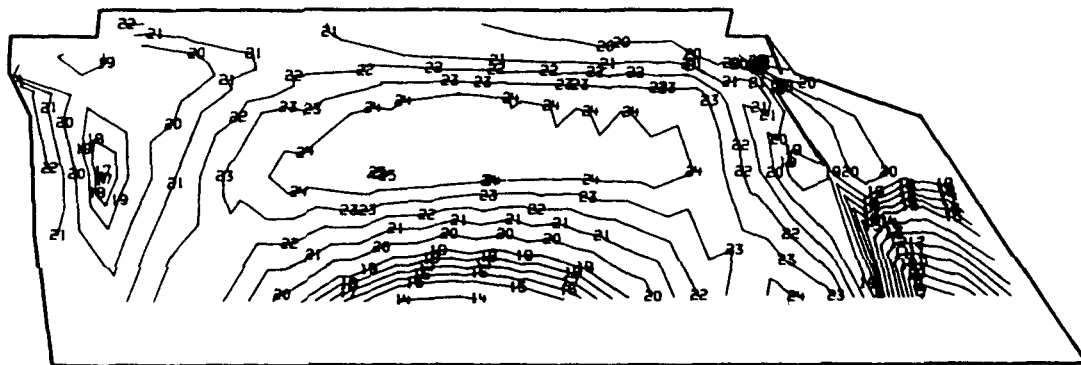

1	-1.500000E 05	12	-4.000000E 04	23	5.000000E 04
2	-1.400000E 05	13	-3.000000E 04	24	6.000000E 04
3	-1.300000E 05	14	-2.000000E 04	25	7.000000E 04
4	-1.200000E 05	15	-1.000000E 04	26	8.000000E 04
5	-1.100000E 05	16	-5.000000E 03	27	9.000000E 04
6	-1.000000E 05	17	0.0	28	1.000000E 05
7	-9.000000E 04	18	5.000000E 03	29	1.100000E 05
8	-8.000000E 04	19	1.000000E 04	30	1.200000E 05
9	-7.000000E 04	20	2.000000E 04	31	1.300000E 05
10	-6.000000E 04	21	3.000000E 04	32	1.400000E 05
11	-5.000000E 04	22	4.000000E 04	33	1.500000E 05

Fig. 2.3-31 Model F-2, FPL Load, View 2, Shank Pressure Side Major Principal Stress (psi)

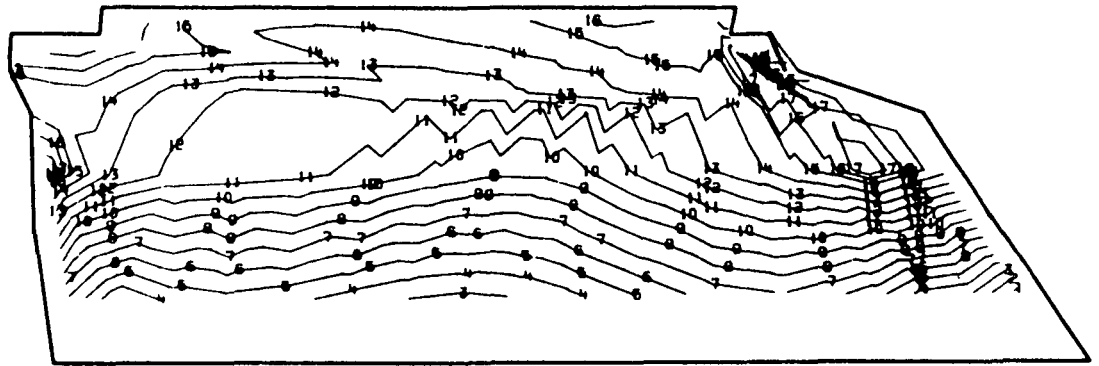

1	-1.500000E 05	12	-4.000000E 04	23	5.000000E 04
2	-1.400000E 05	13	-3.000000E 04	24	6.000000E 04
3	-1.300000E 05	14	-2.000000E 04	25	7.000000E 04
4	-1.200000E 05	15	-1.000000E 04	26	8.000000E 04
5	-1.100000E 05	16	-5.000000E 03	27	9.000000E 04
6	-1.000000E 05	17	0.0	28	1.000000E 05
7	-9.000000E 04	18	5.000000E 03	29	1.100000E 05
8	-8.000000E 04	19	1.000000E 04	30	1.200000E 05
9	-7.000000E 04	20	2.000000E 04	31	1.300000E 05
10	-6.000000E 04	21	3.000000E 04	32	1.400000E 05
11	-5.000000E 04	22	4.000000E 04	33	1.500000E 05

Fig. 2.3-32 Model F-2, FPL Load, View 2, Shank Pressure Side Minor Principal Stress (psi)

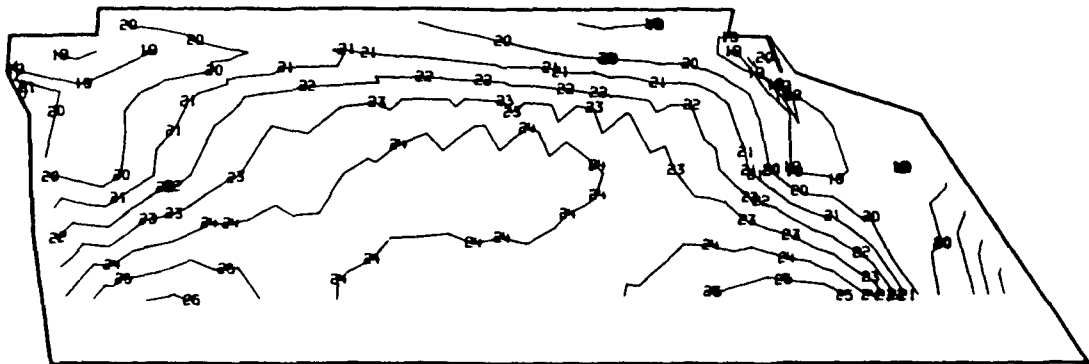

1	-1.500000E 05	12	-4.000000E 04	23	5.000000E 04
2	-1.400000E 05	13	-3.000000E 04	24	6.000000E 04
3	-1.300000E 05	14	-2.000000E 04	25	7.000000E 04
4	-1.200000E 05	15	-1.000000E 04	26	8.000000E 04
5	-1.100000E 05	16	-5.000000E 03	27	9.000000E 04
6	-1.000000E 05	17	0.0	28	1.000000E 05
7	-9.000000E 04	18	5.000000E 03	29	1.100000E 05
8	-8.000000E 04	19	1.000000E 04	30	1.200000E 05
9	-7.000000E 04	20	2.000000E 04	31	1.300000E 05
10	-6.000000E 04	21	3.000000E 04	32	1.400000E 05
11	-5.000000E 04	22	4.000000E 04	33	1.500000E 05

Fig. 2.3-33 Model F-2, FPL Load, View 2, Shank Pressure Side Maximum Principal Shear (psi)

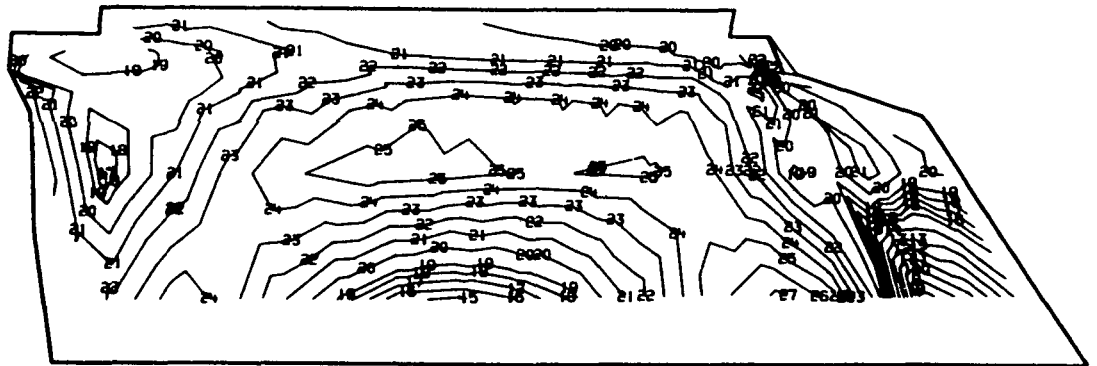

1	-1.500000E 05	12	-4.000000E 04	23	5.000000E 04
2	-1.400000E 05	13	-3.000000E 04	24	6.000000E 04
3	-1.300000E 05	14	-2.000000E 04	25	7.000000E 04
4	-1.200000E 05	15	-1.000000E 04	26	8.000000E 04
5	-1.100000E 05	16	-5.000000E 03	27	9.000000E 04
6	-1.000000E 05	17	0.0	28	1.000000E 05
7	-9.000000E 04	18	5.000000E 03	29	1.100000E 05
8	-8.000000E 04	19	1.000000E 04	30	1.200000E 05
9	-7.000000E 04	20	2.000000E 04	31	1.300000E 05
10	-6.000000E 04	21	3.000000E 04	32	1.400000E 05
11	-5.000000E 04	22	4.000000E 04	33	1.500000E 05

Fig. 2.3-34 Model F2, 115% Load, View 2, Shank Pressure Side Major Principal Stress (psi)

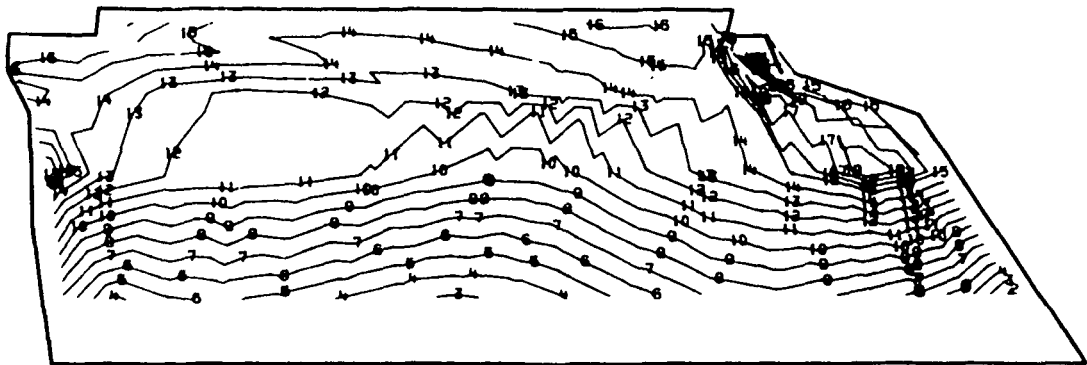

1	-1.500000E 05	12	-4.000000E 04	23	5.000000E 04
2	-1.400000E 05	13	-3.000000E 04	24	6.000000E 04
3	-1.300000E 05	14	-2.000000E 04	25	7.000000E 04
4	-1.200000E 05	15	-1.000000E 04	26	8.000000E 04
5	-1.100000E 05	16	-5.000000E 03	27	9.000000E 04
6	-1.000000E 05	17	0.0	28	1.000000E 05
7	-9.000000E 04	18	5.000000E 03	29	1.100000E 05
8	-8.000000E 04	19	1.000000E 04	30	1.200000E 05
9	-7.000000E 04	20	2.000000E 04	31	1.300000E 05
10	-6.000000E 04	21	3.000000E 04	32	1.400000E 05
11	-5.000000E 04	22	4.000000E 04	33	1.500000E 05

Fig. 2.3-35 Model F-2, 115% Load, View 2, Shank Pressure Side Minor Principal Stress (psi)

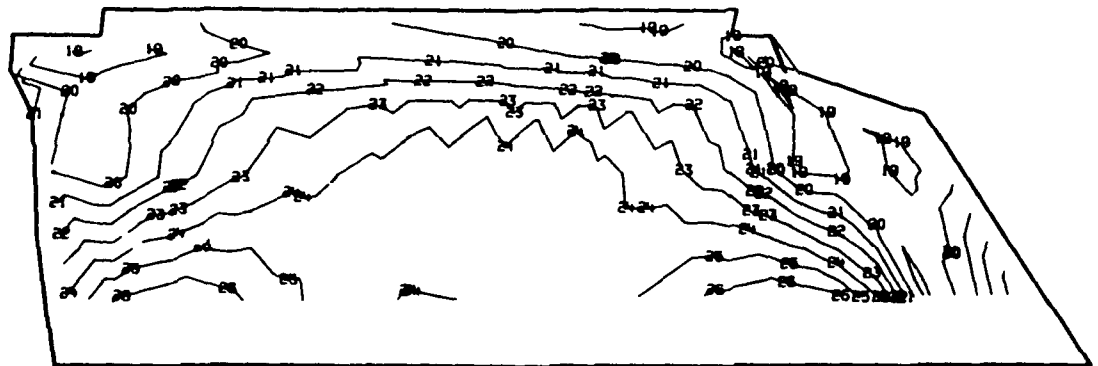

1	-1.500000E 05	12	-4.000000E 04	23	5.000000E 04
2	-1.400000E 05	13	-3.000000E 04	24	6.000000E 04
3	-1.300000E 05	14	-2.000000E 04	25	7.000000E 04
4	-1.200000E 05	15	-1.000000E 04	26	8.000000E 04
5	-1.100000E 05	16	-5.000000E 03	27	9.000000E 04
6	-1.000000E 05	17	0.0	28	1.000000E 05
7	-9.000000E 04	18	5.000000E 03	29	1.100000E 05
8	-8.000000E 04	19	1.000000E 04	30	1.200000E 05
9	-7.000000E 04	20	2.000000E 04	31	1.300000E 05
10	-6.000000E 04	21	3.000000E 04	32	1.400000E 05
11	-5.000000E 04	22	4.000000E 04	33	1.500000E 05

Fig. 2.3-36 Model F-2, 115% Load, View 2, Shank Pressure Side Maximum Principal Shear (psi)

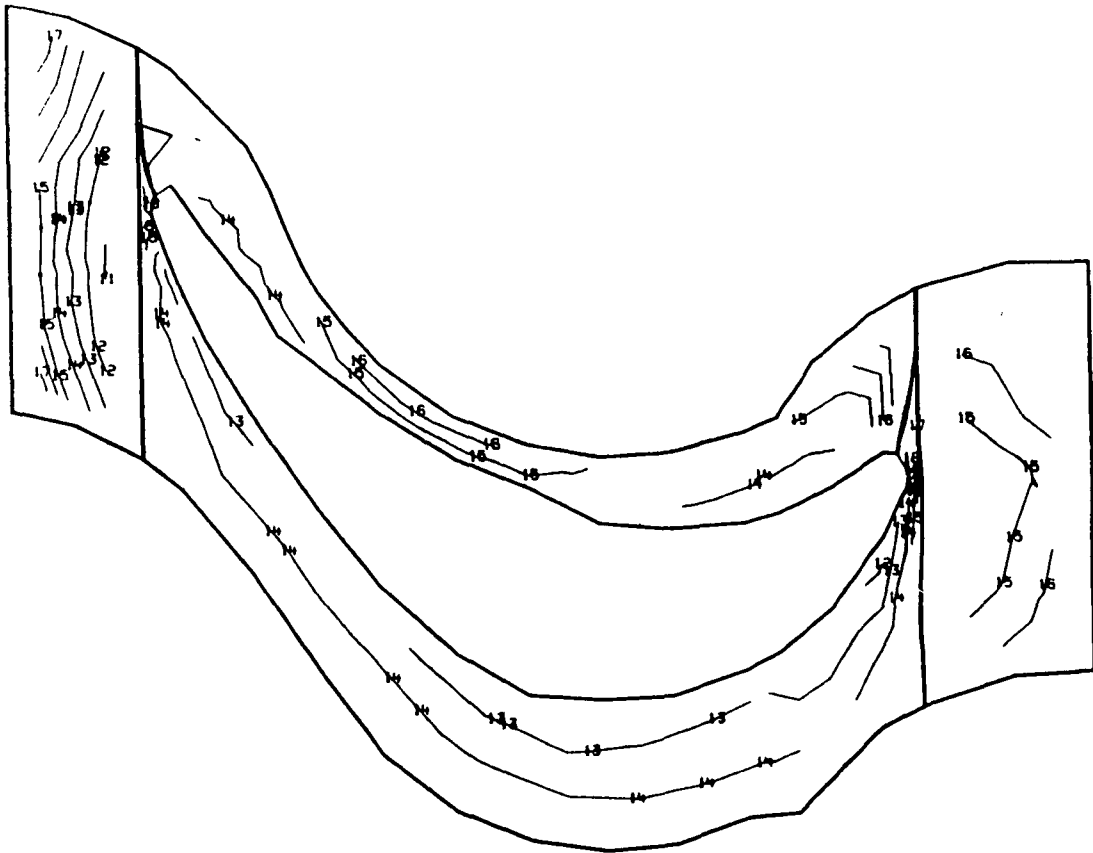

1	-1.500000E 05	12	-4.000000E 04	23	5.000000E 04
2	-1.400000E 05	13	-3.000000E 04	24	6.000000E 04
3	-1.300000E 05	14	-2.000000E 04	25	7.000000E 04
4	-1.200000E 05	15	-1.000000E 04	26	8.000000E 04
5	-1.100000E 05	16	-5.000000E 03	27	9.000000E 04
6	-1.000000E 05	17	0.0	28	1.000000E 05
7	-9.000000E 04	18	5.000000E 03	29	1.100000E 05
8	-8.000000E 04	19	1.000000E 04	30	1.200000E 05
9	-7.000000E 04	20	2.000000E 04	31	1.300000E 05
10	-6.000000E 04	21	3.000000E 04	32	1.400000E 05
11	-5.000000E 04	22	4.000000E 04	33	1.500000E 05

Fig. 2.3-37 Model F-2, FPL Load, View 3, Platform Top Major Principal Stress (psi)

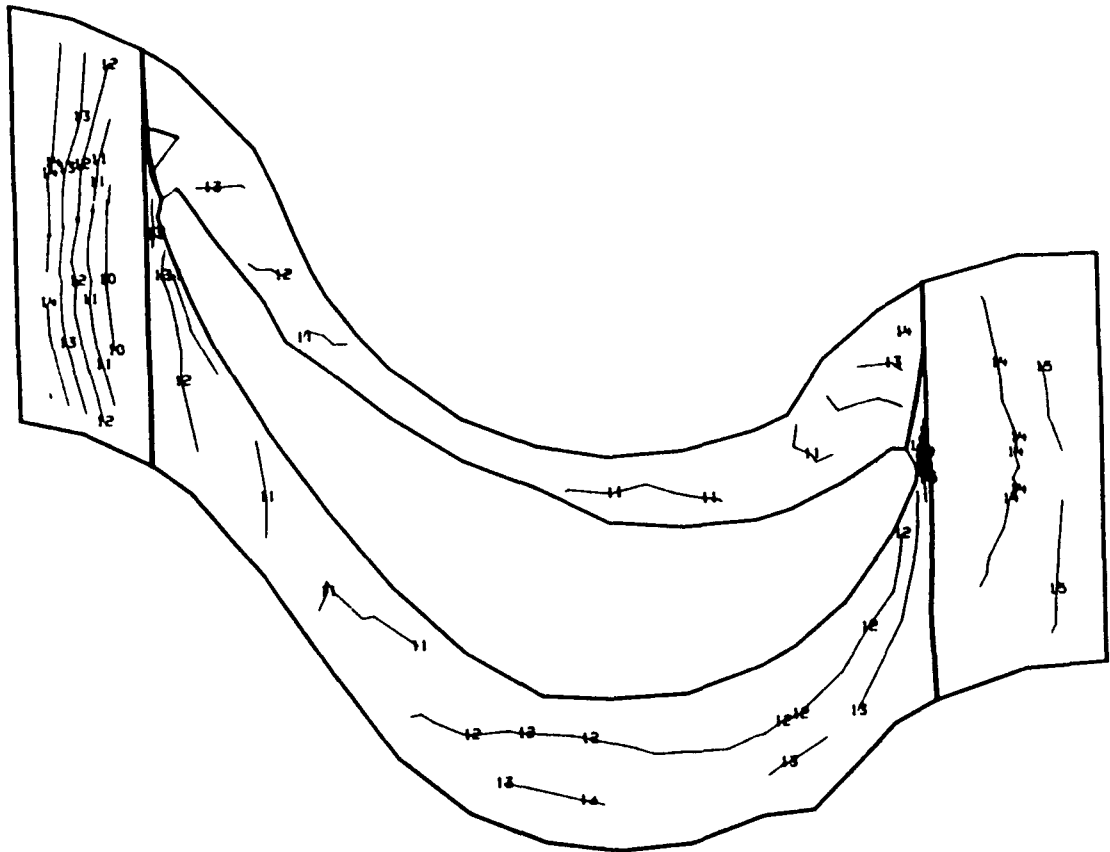

1	-1.500000E 05	12	-4.000000E 04	23	5.000000E 04
2	-1.400000E 05	13	-3.000000E 04	24	6.000000E 04
3	-1.300000E 05	14	-2.000000E 04	25	7.000000E 04
4	-1.200000E 05	15	-1.000000E 04	26	8.000000E 04
5	-1.100000E 05	16	-5.000000E 03	27	9.000000E 04
6	-1.000000E 05	17	0.0	28	1.000000E 05
7	-9.000000E 04	18	5.000000E 03	29	1.100000E 05
8	-8.000000E 04	19	1.000000E 04	30	1.200000E 05
9	-7.000000E 04	20	2.000000E 04	31	1.300000E 05
10	-6.000000E 04	21	3.000000E 04	32	1.400000E 05
11	-5.000000E 04	22	4.000000E 04	33	1.500000E 05

Fig. 2.3-38 Model F-2, FPL Load, View 3, Platform Top Minor Principal Stress (psi)

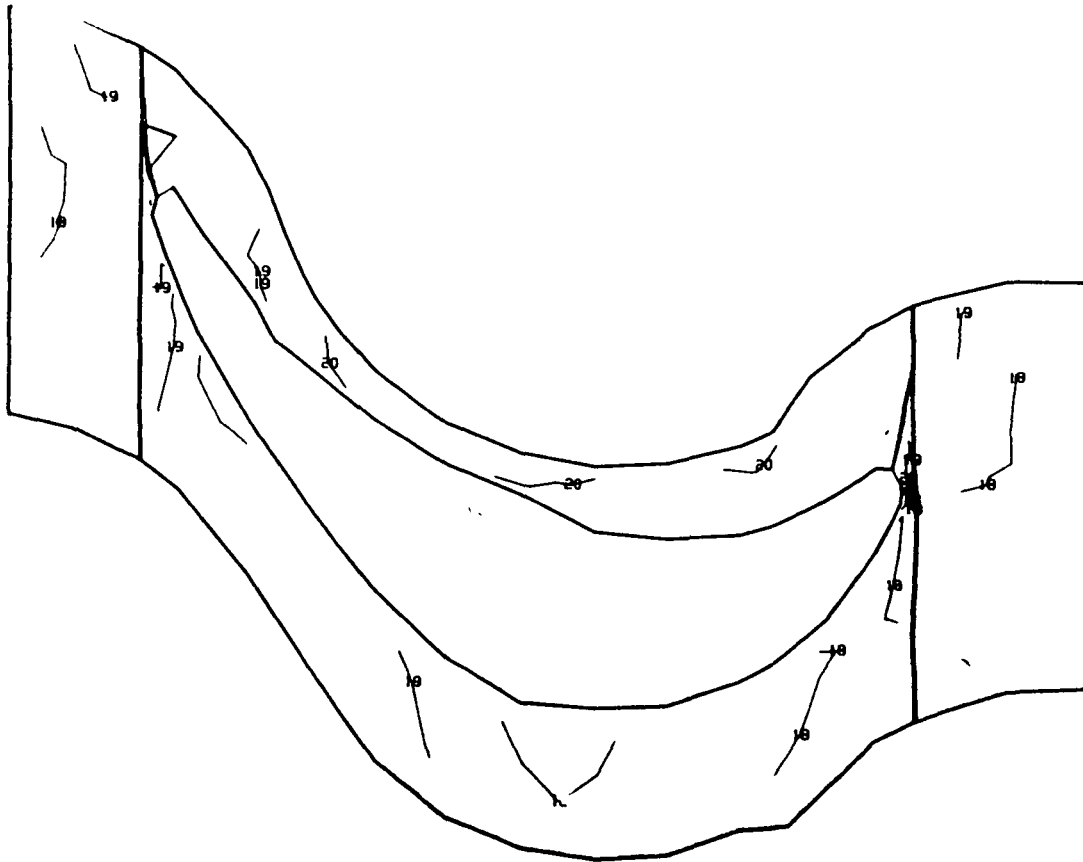

1	-1.500000E 05	12	-4.000000E 04	23	5.000000E 04
2	-1.400000E 05	13	-3.000000E 04	24	6.000000E 04
3	-1.300000E 05	14	-2.000000E 04	25	7.000000E 04
4	-1.200000E 05	15	-1.000000E 04	26	8.000000E 04
5	-1.100000E 05	16	-5.000000E 03	27	9.000000E 04
6	-1.000000E 05	17	0.0	28	1.000000E 05
7	-9.000000E 04	18	5.000000E 03	29	1.100000E 05
8	-8.000000E 04	19	1.000000E 04	30	1.200000E 05
9	-7.000000E 04	20	2.000000E 04	31	1.300000E 05
10	-6.000000E 04	21	3.000000E 04	32	1.400000E 05
11	-5.000000E 04	22	4.000000E 04	33	1.500000E 05

Fig. 2.3-39 Model F-2, FPL Load, View 3, Platform Top Maximum Principal Shear (psi)

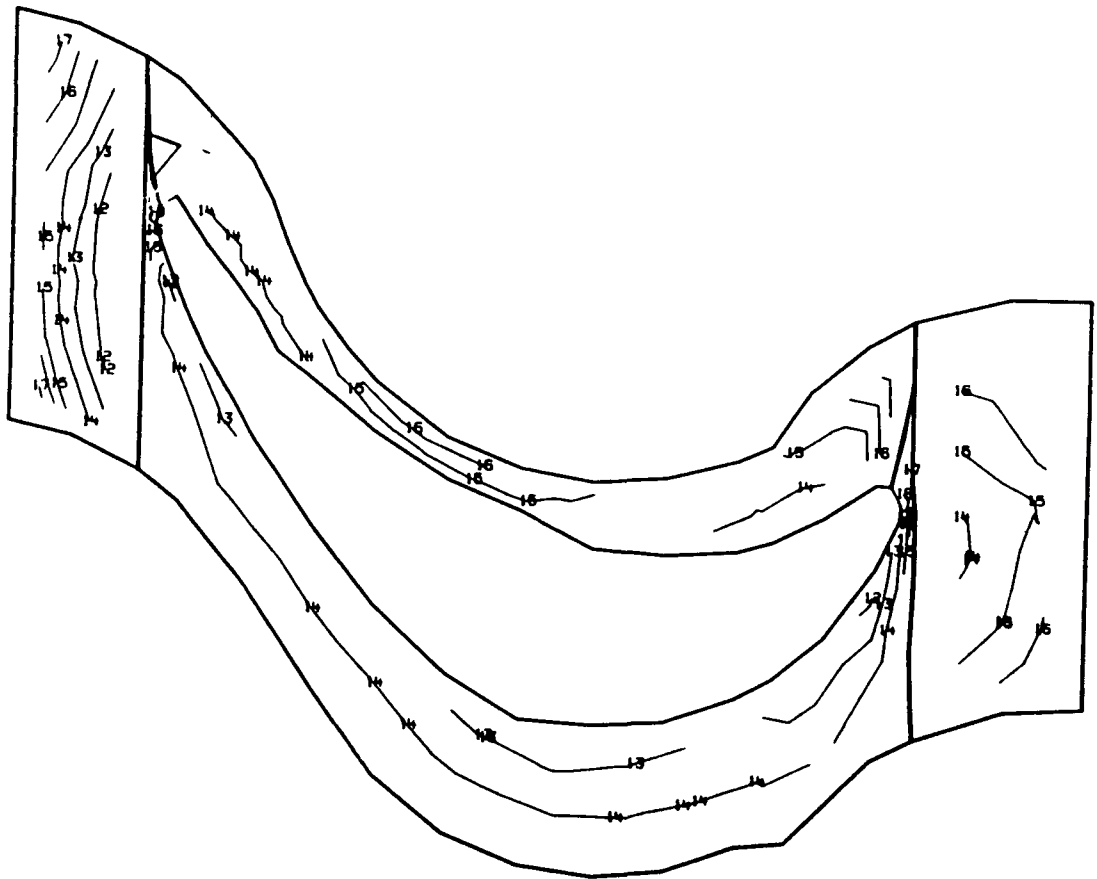

1	-1.500000E 05	12	-4.000000E 04	23	5.000000E 04
2	-1.400000E 05	13	-3.000000E 04	24	6.000000E 04
3	-1.300000E 05	14	-2.000000E 04	25	7.000000E 04
4	-1.200000E 05	15	-1.000000E 04	26	8.000000E 04
5	-1.100000E 05	16	-5.000000E 03	27	9.000000E 04
6	-1.000000E 05	17	0.0	28	1.000000E 05
7	-9.000000E 04	18	5.000000E 03	29	1.100000E 05
8	-8.000000E 04	19	1.000000E 04	30	1.200000E 05
9	-7.000000E 04	20	2.000000E 04	31	1.300000E 05
10	-6.000000E 04	21	3.000000E 04	32	1.400000E 05
11	-5.000000E 04	22	4.000000E 04	33	1.500000E 05

Fig. 2.3-40 Model F-2, 115% Load, View 3, Platform Top Major Principal Stress (psi)

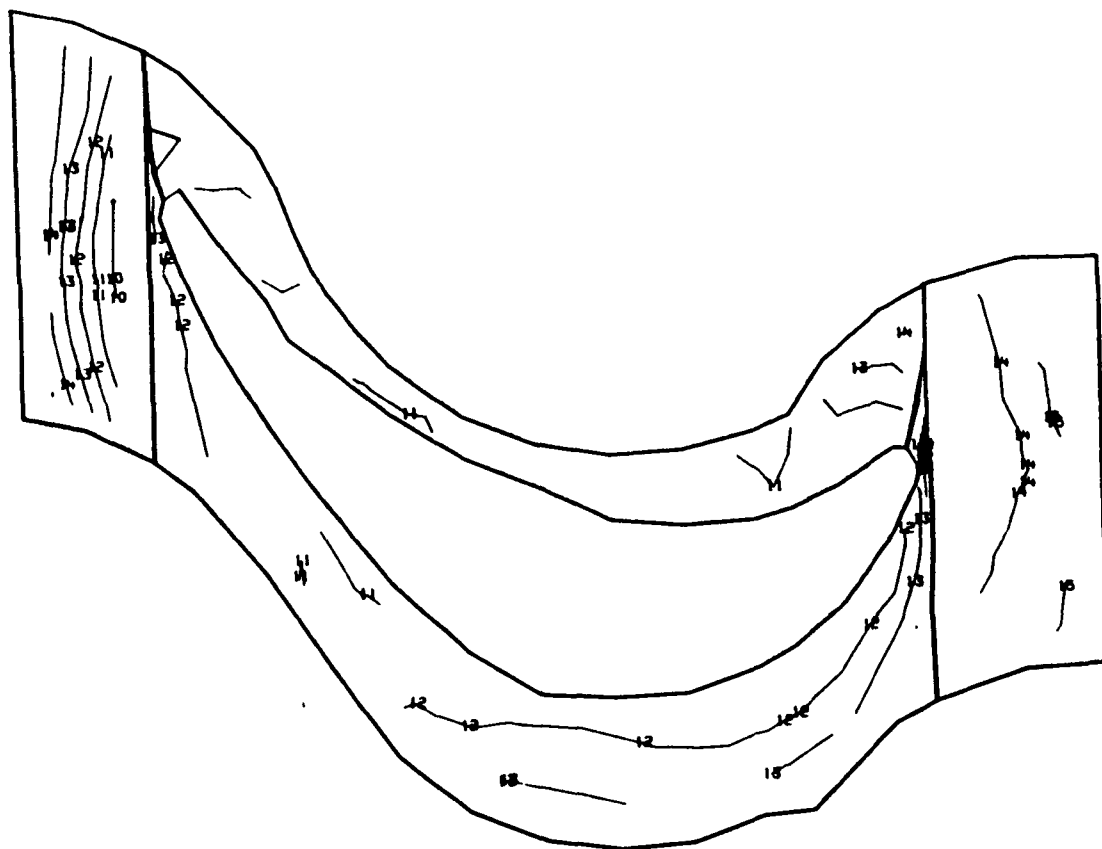

1	-1.500000E 05	12	-4.000000E 04	23	5.000000E 04
2	-1.400000E 05	13	-3.000000E 04	24	6.000000E 04
3	-1.300000E 05	14	-2.000000E 04	25	7.000000E 04
4	-1.200000E 05	15	-1.000000E 04	26	8.000000E 04
5	-1.100000E 05	16	-5.000000E 03	27	9.000000E 04
6	-1.000000E 05	17	0.0	28	1.000000E 05
7	-9.000000E 04	18	5.000000E 03	29	1.100000E 05
8	-8.000000E 04	19	1.000000E 04	30	1.200000E 05
9	-7.000000E 04	20	2.000000E 04	31	1.300000E 05
10	-6.000000E 04	21	3.000000E 04	32	1.400000E 05
11	-5.000000E 04	22	4.000000E 04	33	1.500000E 05

Fig. 2.3-41 Model F-2, 115% Load, View 3, Platform Top Minor Principal Stress (psi)

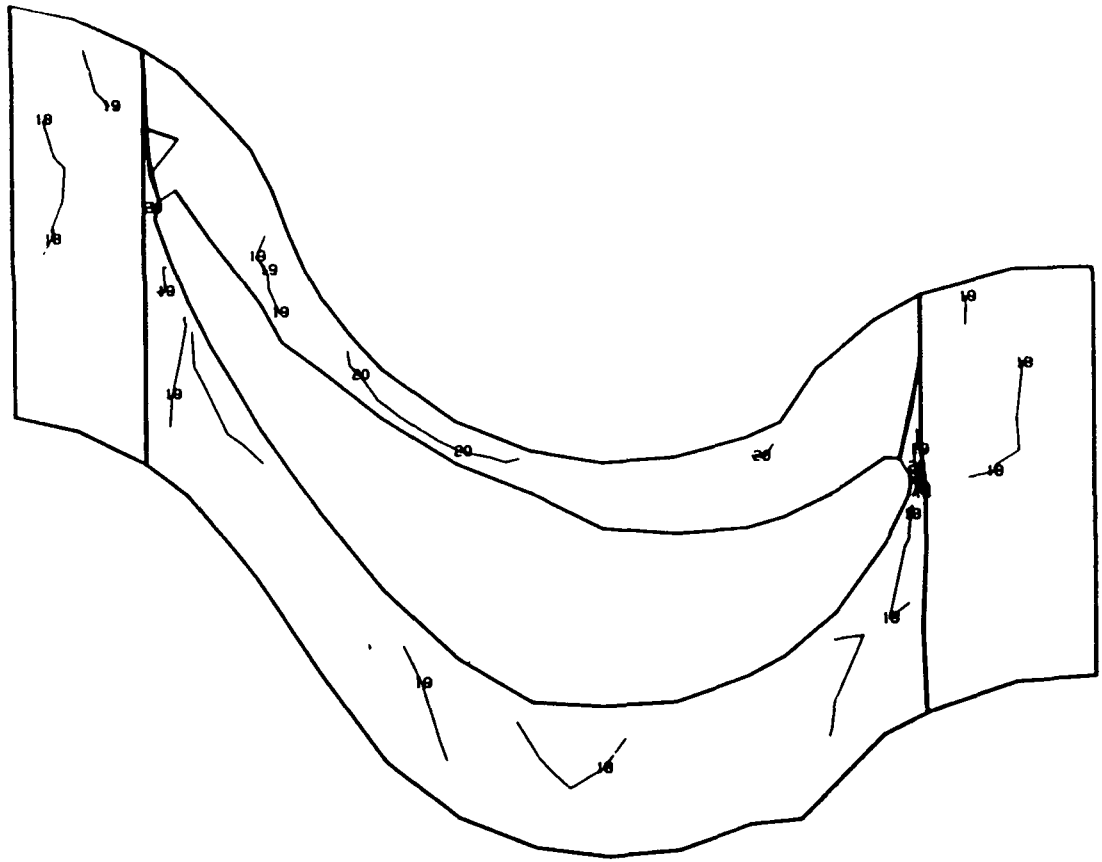

1	-1.500000E 05	12	-4.000000E 04	23	5.000000E 04
2	-1.400000E 05	13	-3.000000E 04	24	6.000000E 04
3	-1.300000E 05	14	-2.000000E 04	25	7.000000E 04
4	-1.200000E 05	15	-1.000000E 04	26	8.000000E 04
5	-1.100000E 05	16	-5.000000E 03	27	9.000000E 04
6	-1.000000E 05	17	0.0	28	1.000000E 05
7	-9.000000E 04	18	5.000000E 03	29	1.100000E 05
8	-8.000000E 04	19	1.000000E 04	30	1.200000E 05
9	-7.000000E 04	20	2.000000E 04	31	1.300000E 05
10	-6.000000E 04	21	3.000000E 04	32	1.400000E 05
11	-5.000000E 04	22	4.000000E 04	33	1.500000E 05

Fig. 2.3-42 Model F-2, 115% Load, View 3, Platform Top Maximum Principal Shear (psi)

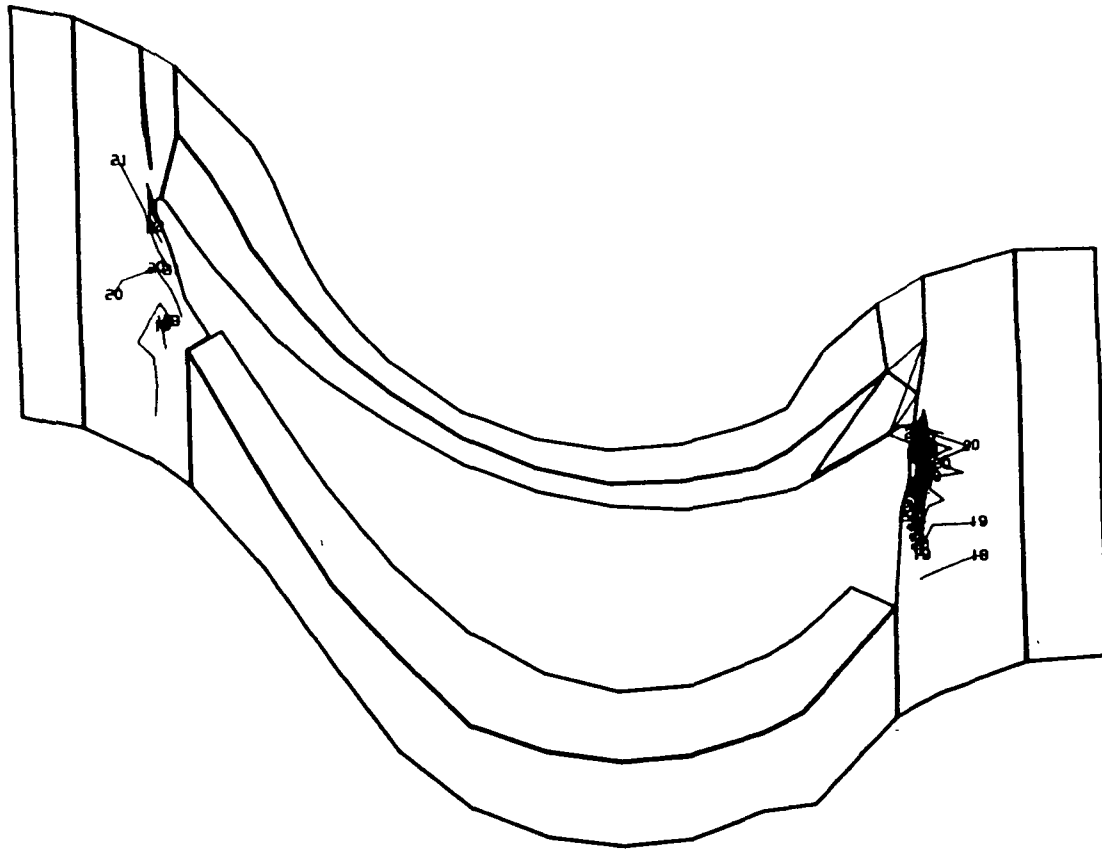

1	-1.500000E 05	12	-4.000000E 04	23	5.000000E 04
2	-1.400000E 05	13	-3.000000E 04	24	6.000000E 04
3	-1.300000E 05	14	-2.000000E 04	25	7.000000E 04
4	-1.200000E 05	15	-1.000000E 04	26	8.000000E 04
5	-1.100000E 05	16	-5.000000E 03	27	9.000000E 04
6	-1.000000E 05	17	0.0	28	1.000000E 05
7	-9.000000E 04	18	5.000000E 03	29	1.100000E 05
8	-8.000000E 04	19	1.000000E 04	30	1.200000E 05
9	-7.000000E 04	20	2.000000E 04	31	1.300000E 05
10	-6.000000E 04	21	3.000000E 04	32	1.400000E 05
11	-5.000000E 04	22	4.000000E 04	33	1.500000E 05

Fig. 2.3-43 Model F-2, FPL Load, View 3, Platform Bottom Major Principal Stress (psi)

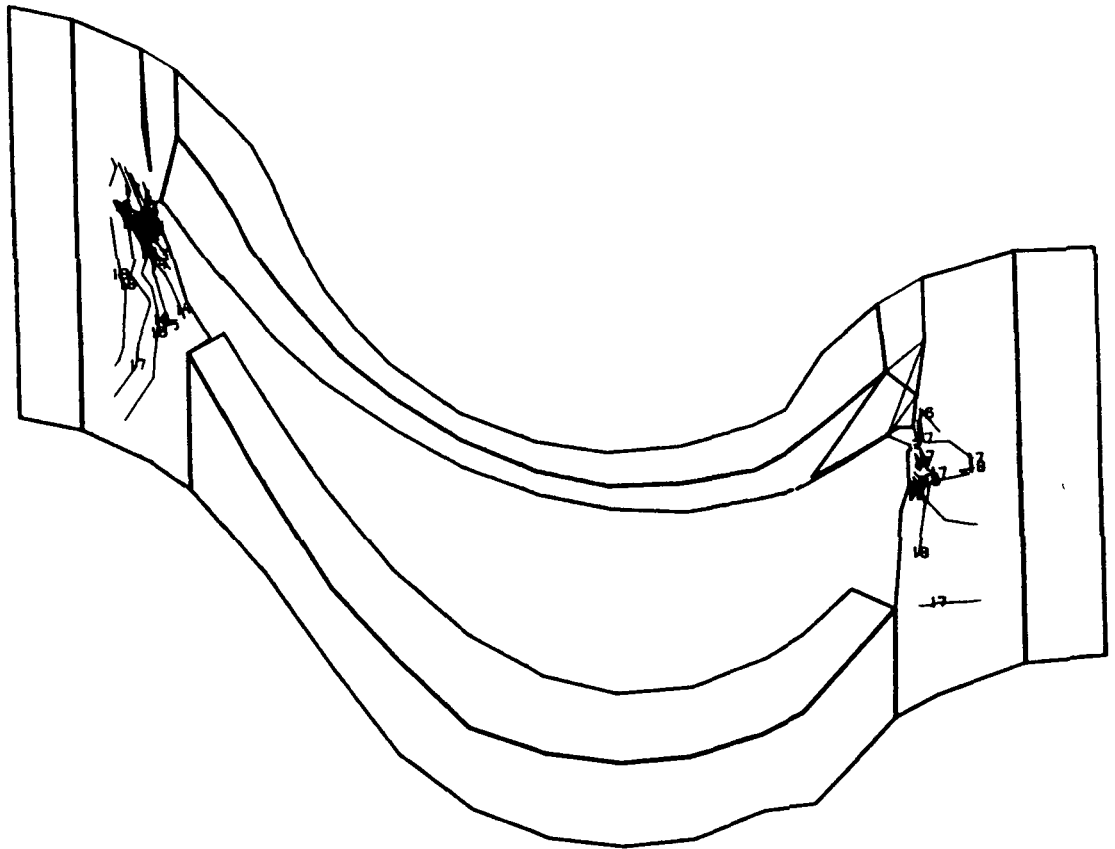

1	-1.500000E 05	12	-4.000000E 04	23	5.000000E 04
2	-1.400000E 05	13	-3.000000E 04	24	6.000000E 04
3	-1.300000E 05	14	-2.000000E 04	25	7.000000E 04
4	-1.200000E 05	15	-1.000000E 04	26	8.000000E 04
5	-1.100000E 05	16	-5.000000E 03	27	9.000000E 04
6	-1.000000E 05	17	0.0	28	1.000000E 05
7	-9.000000E 04	18	5.000000E 03	29	1.100000E 05
8	-8.000000E 04	19	1.000000E 04	30	1.200000E 05
9	-7.000000E 04	20	2.000000E 04	31	1.300000E 05
10	-6.000000E 04	21	3.000000E 04	32	1.400000E 05
11	-5.000000E 04	22	4.000000E 04	33	1.500000E 05

Fig. 2.3-44 Model F-2, FPL Load, View 3, Platform Bottom Minor Principal Stress (ps)

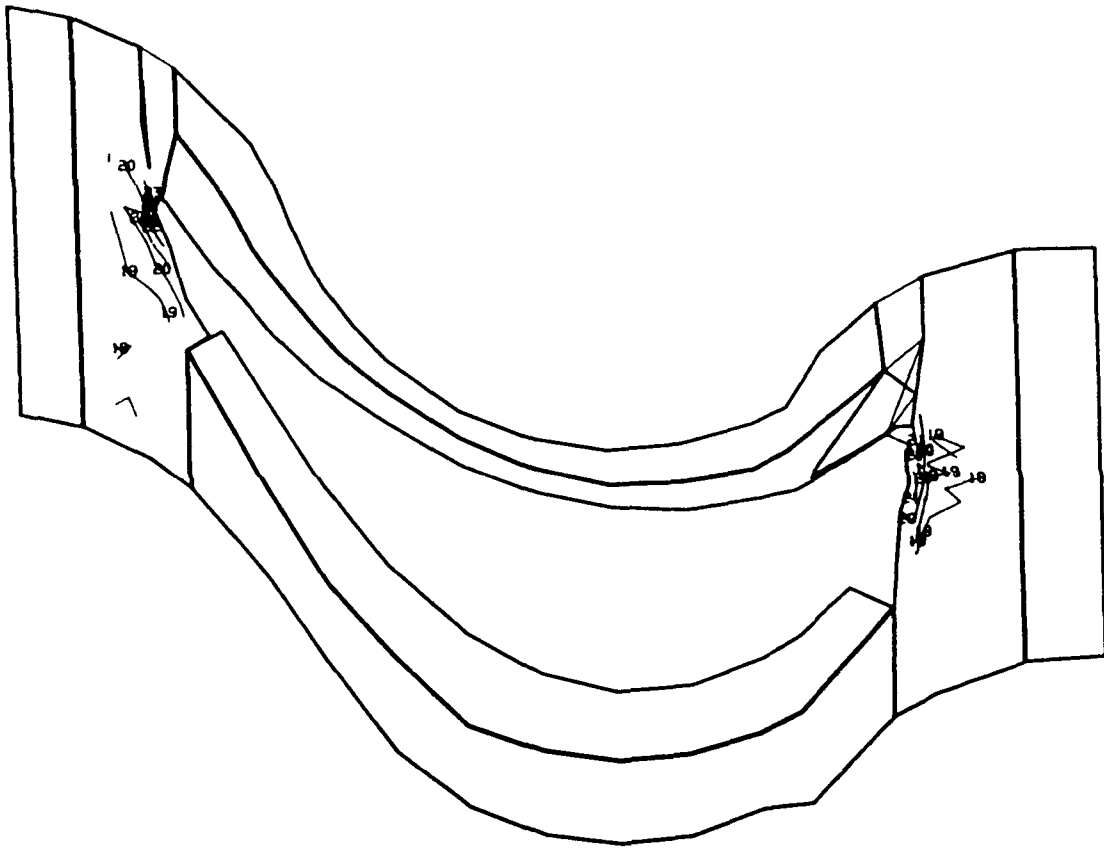

1	-1.500000E 05	12	-4.000000E 04	23	5.000000E 04
2	-1.400000E 05	13	-3.000000E 04	24	6.000000E 04
3	-1.300000E 05	14	-2.000000E 04	25	7.000000E 04
4	-1.200000E 05	15	-1.000000E 04	26	8.000000E 04
5	-1.100000E 05	16	-5.000000E 03	27	9.000000E 04
6	-1.000000E 05	17	0.0	28	1.000000E 05
7	-9.000000E 04	18	5.000000E 03	29	1.100000E 05
8	-8.000000E 04	19	1.000000E 04	30	1.200000E 05
9	-7.000000E 04	20	2.000000E 04	31	1.300000E 05
10	-6.000000E 04	21	3.000000E 04	32	1.400000E 05
11	-5.000000E 04	22	4.000000E 04	33	1.500000E 05

Fig. 2.3-45 Model F-2, FPL Load, View 3, Platform Bottom Maximum Principal Shear (psi)

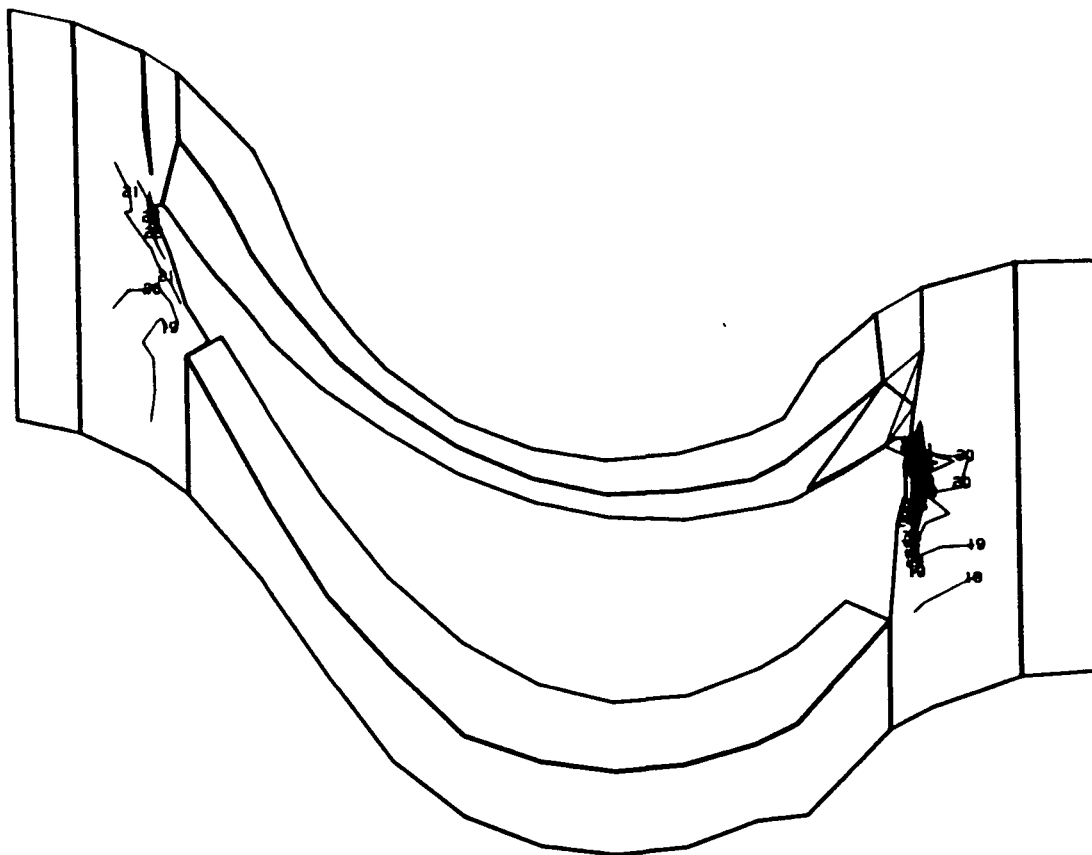

1	-1.500000E 05	12	-4.000000E 04	23	5.000000E 04
2	-1.400000E 05	13	-3.000000E 04	24	6.000000E 04
3	-1.300000E 05	14	-2.000000E 04	25	7.000000E 04
4	-1.200000E 05	15	-1.000000E 04	26	8.000000E 04
5	-1.100000E 05	16	-5.000000E 03	27	9.000000E 04
6	-1.000000E 05	17	0.0	28	1.000000E 05
7	-9.000000E 04	18	5.000000E 03	29	1.100000E 05
8	-8.000000E 04	19	1.000000E 04	30	1.200000E 05
9	-7.000000E 04	20	2.000000E 04	31	1.300000E 05
10	-6.000000E 04	21	3.000000E 04	32	1.400000E 05
11	-5.000000E 04	22	4.000000E 04	33	1.500000E 05

Fig. 2.3-46 Model F-2, 115% Load, View 3, Platform Bottom Major Principal Stress (psi)

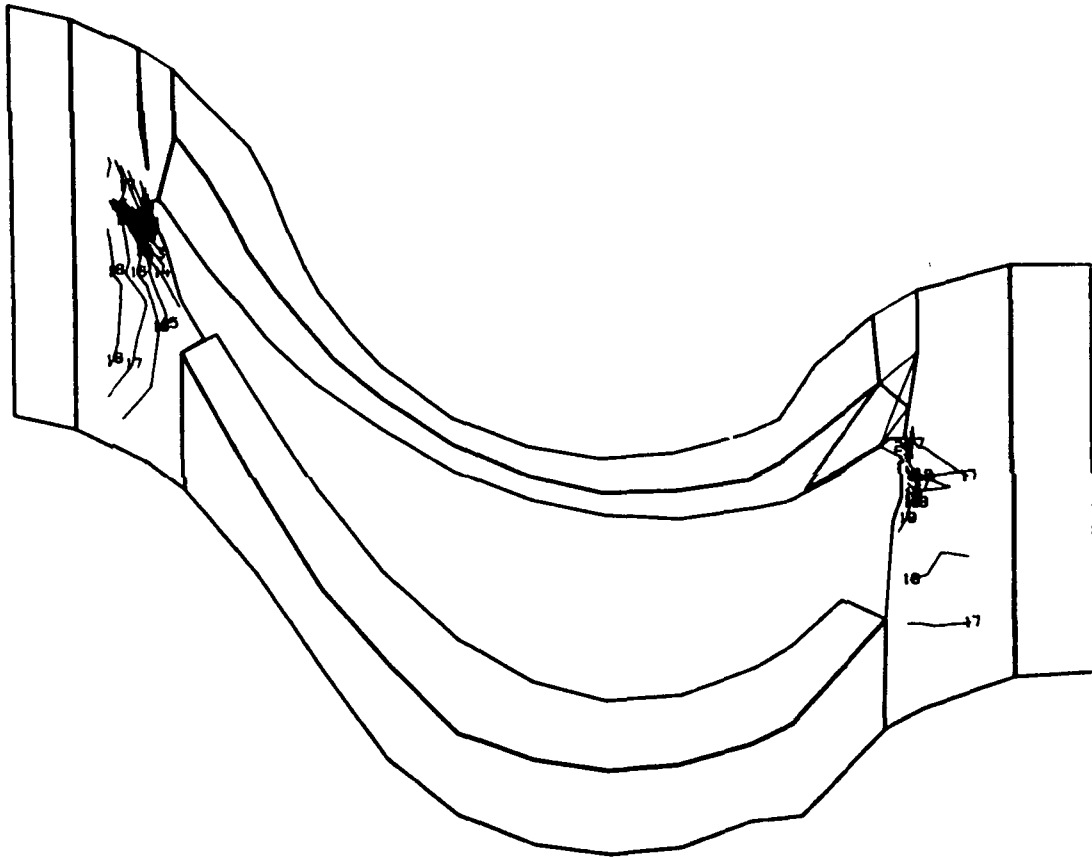

1	-1.500000E 05	12	-4.000000E 04	23	5.000000E 04
2	-1.400000E 05	13	-3.000000E 04	24	6.000000E 04
3	-1.300000E 05	14	-2.000000E 04	25	7.000000E 04
4	-1.200000E 05	15	-1.000000E 04	26	8.000000E 04
5	-1.100000E 05	16	-5.000000E 03	27	9.000000E 04
6	-1.000000E 05	17	0.0	28	1.000000E 05
7	-9.000000E 04	18	5.000000E 03	29	1.100000E 05
8	-8.000000E 04	19	1.000000E 04	30	1.200000E 05
9	-7.000000E 04	20	2.000000E 04	31	1.300000E 05
10	-6.000000E 04	21	3.000000E 04	32	1.400000E 05
11	-5.000000E 04	22	4.000000E 04	33	1.500000E 05

Fig. 2.3-47 Model F-2, 115% Load, View 3, Platform Bottom Minor Principal Stress (psi)

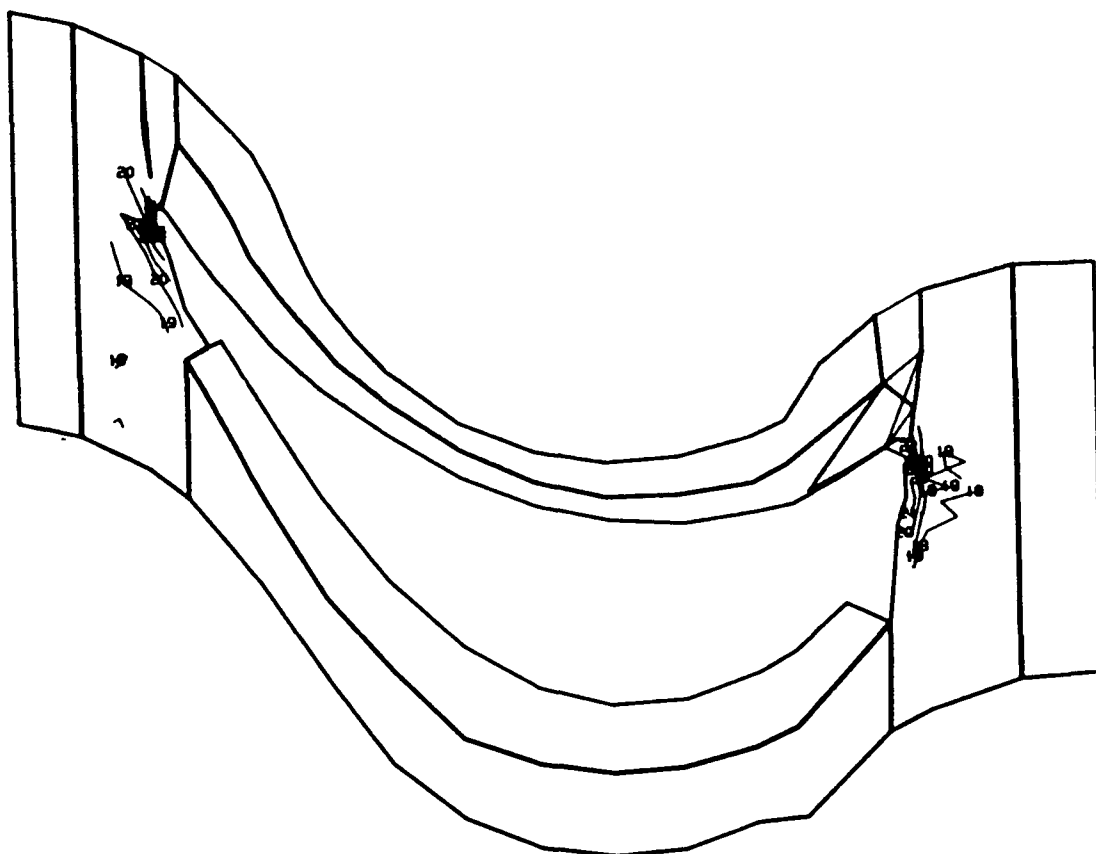

1	-1.500000E 05	12	-4.000000E 04	23	5.000000E 04
2	-1.400000E 05	13	-3.000000E 04	24	6.000000E 04
3	-1.300000E 05	14	-2.000000E 04	25	7.000000E 04
4	-1.200000E 05	15	-1.000000E 04	26	8.000000E 04
5	-1.100000E 05	16	-5.000000E 03	27	9.000000E 04
6	-1.000000E 05	17	0.0	28	1.000000E 05
7	-9.000000E 04	18	5.000000E 03	29	1.100000E 05
8	-8.000000E 04	19	1.000000E 04	30	1.200000E 05
9	-7.000000E 04	20	2.000000E 04	31	1.300000E 05
10	-6.000000E 04	21	3.000000E 04	32	1.400000E 05
11	-5.000000E 04	22	4.000000E 04	33	1.500000E 05

Fig. 2.3-48 Model F-2, 115% Load, View 3, Platform Bottom Maximum Principal Shear (psi)

2.4 HPOTP FIRST STAGE TURBINE BLADE TEMPERATURES AND STRESSES AT FPL AND 115% RPL

Figure 2.4-1 shows the views that are used in generating contour plots for both of the HPOTP blades. Surface temperatures are shown in Figs. 2.4-2 through 2.4-17. Surface stresses are shown in Figs. 2.4-18 through 2.4-65.

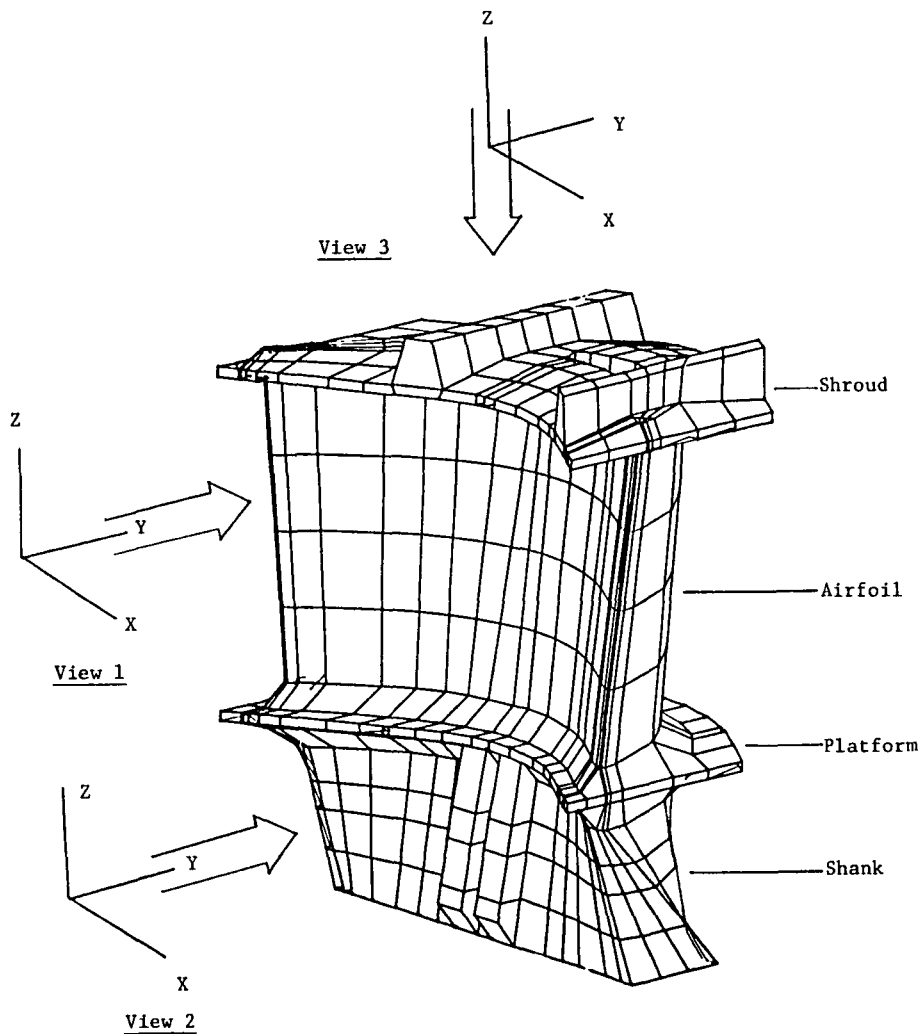
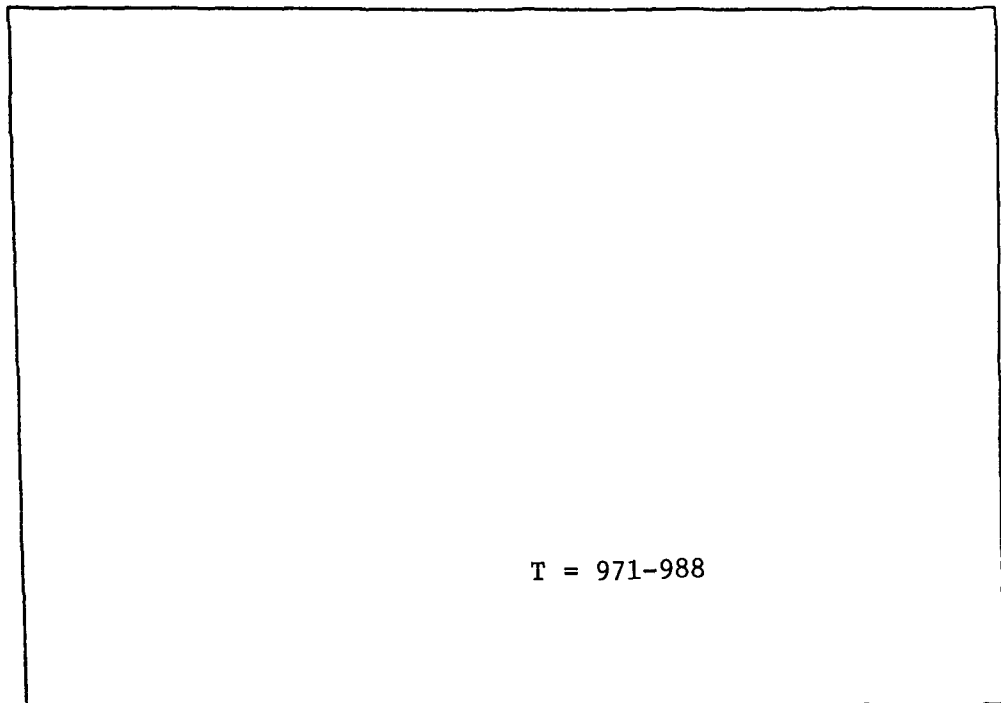
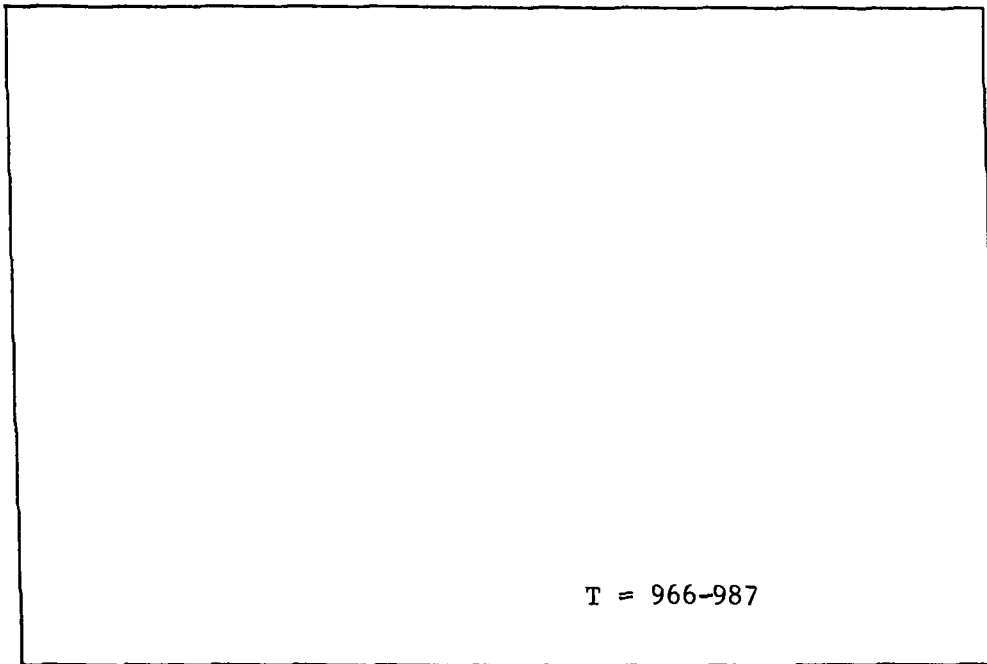

Fig. 2.4-1 Typical Model, Contour Plot Views



1	-3.000000E 02	14	3.500000E 02	27	1.000000E 03
2	-2.500000E 02	15	4.000000E 02	28	1.050000E 03
3	-2.000000E 02	16	4.500000E 02	29	1.100000E 03
4	-1.500000E 02	17	5.000000E 02	30	1.150000E 03
5	-1.000000E 02	18	5.500000E 02	31	1.200000E 03
6	-5.000000E 01	19	6.000000E 02	32	1.250000E 03
7	0.0	20	6.500000E 02	33	1.300000E 03
8	5.000000E 01	21	7.000000E 02	34	1.350000E 03
9	1.000000E 02	22	7.500000E 02	35	1.400000E 03
10	1.500000E 02	23	8.000000E 02	36	1.450000E 03
11	2.000000E 02	24	8.500000E 02	37	1.500000E 03
12	2.500000E 02	25	9.000000E 02	38	1.550000E 03
13	3.000000E 02	26	9.500000E 02	39	1.600000E 03

Fig. 2.4-2 Model 0-1, FPL Load, View 1, Airfoil Pressure Side Steady State Surface Temperature (F)



1	-3.000000E 02	14	3.500000E 02	27	1.000000E 03
2	-2.500000E 02	15	4.000000E 02	28	1.050000E 03
3	-2.000000E 02	16	4.500000E 02	29	1.100000E 03
4	-1.500000E 02	17	5.000000E 02	30	1.150000E 03
5	-1.000000E 02	18	5.500000E 02	31	1.200000E 03
6	-5.000000E 01	19	6.000000E 02	32	1.250000E 03
7	0.0	20	6.500000E 02	33	1.300000E 03
8	5.000000E 01	21	7.000000E 02	34	1.350000E 03
9	1.000000E 02	22	7.500000E 02	35	1.400000E 03
10	1.500000E 02	23	8.000000E 02	36	1.450000E 03
11	2.000000E 02	24	8.500000E 02	37	1.500000E 03
12	2.500000E 02	25	9.000000E 02	38	1.550000E 03
13	3.000000E 02	26	9.500000E 02	39	1.600000E 03

Fig. 2.4-3 Model O-1, FPL Load, View 1, Airfoil Suction Side Steady State Surface Temperature (F)

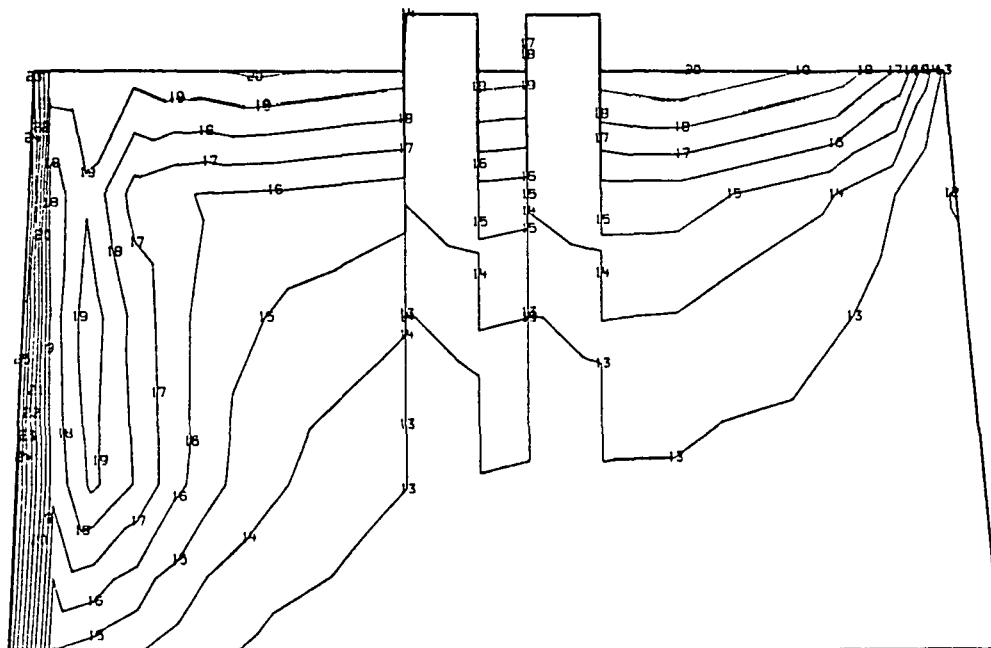

1	-3.000000E 02	14	3.500000E 02	27	1.000000E 03
2	-2.500000E 02	15	4.000000E 02	28	1.050000E 03
3	-2.000000E 02	16	4.500000E 02	29	1.100000E 03
4	-1.500000E 02	17	5.000000E 02	30	1.150000E 03
5	-1.000000E 02	18	5.500000E 02	31	1.200000E 03
6	-5.000000E 01	19	6.000000E 02	32	1.250000E 03
7	0.0	20	6.500000E 02	33	1.300000E 03
8	5.000000E 01	21	7.000000E 02	34	1.350000E 03
9	1.000000E 02	22	7.500000E 02	35	1.400000E 03
10	1.500000E 02	23	8.000000E 02	36	1.450000E 03
11	2.000000E 02	24	8.500000E 02	37	1.500000E 03
12	2.500000E 02	25	9.000000E 02	38	1.550000E 03
13	3.000000E 02	26	9.500000E 02	39	1.600000E 03

Fig. 2.4-4 Model 0-1, FPL Load, View 2, Shank Pressure Side Steady State Surface Temperatures (F)

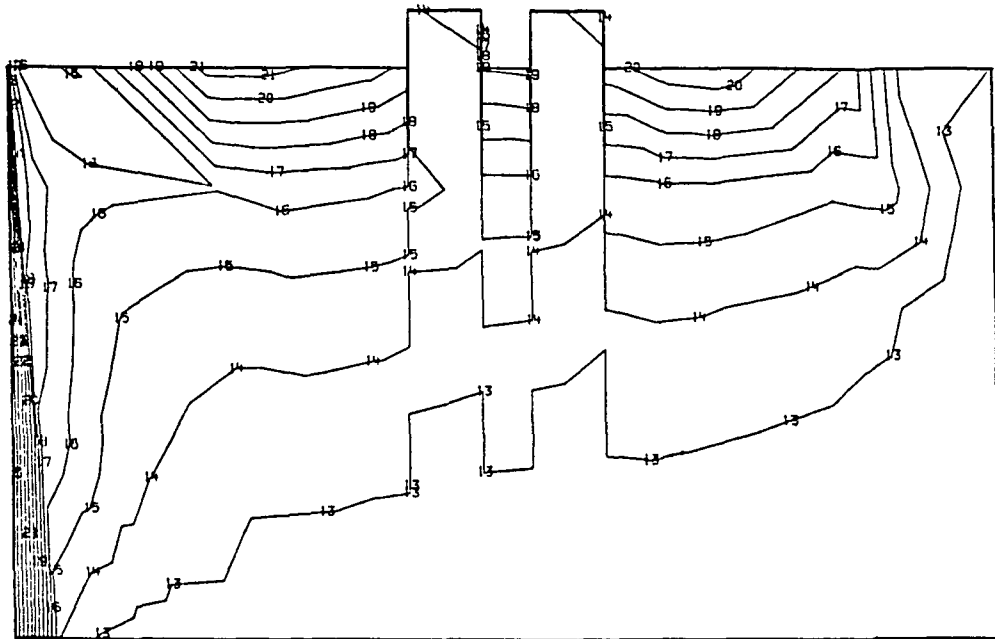

1	-3.000000E 02	14	3.500000E 02	27	1.000000E 03
2	-2.500000E 02	15	4.000000E 02	28	1.050000E 03
3	-2.000000E 02	16	4.500000E 02	29	1.100000E 03
4	-1.500000E 02	17	5.000000E 02	30	1.150000E 03
5	-1.000000E 02	18	5.500000E 02	31	1.200000E 03
6	-5.000000E 01	19	6.000000E 02	32	1.250000E 03
7	0.0	20	6.500000E 02	33	1.300000E 03
8	5.000000E 01	21	7.000000E 02	34	1.350000E 03
9	1.000000E 02	22	7.500000E 02	35	1.400000E 03
10	1.500000E 02	23	8.000000E 02	36	1.450000E 03
11	2.000000E 02	24	8.500000E 02	37	1.500000E 03
12	2.500000E 02	25	9.000000E 02	38	1.550000E 03
13	3.000000E 02	26	9.500000E 02	39	1.600000E 03

Fig. 2.4-5 Model 0-1, FPL Load, View 2, Shank Suction Side Steady State Surface Temperatures (F)

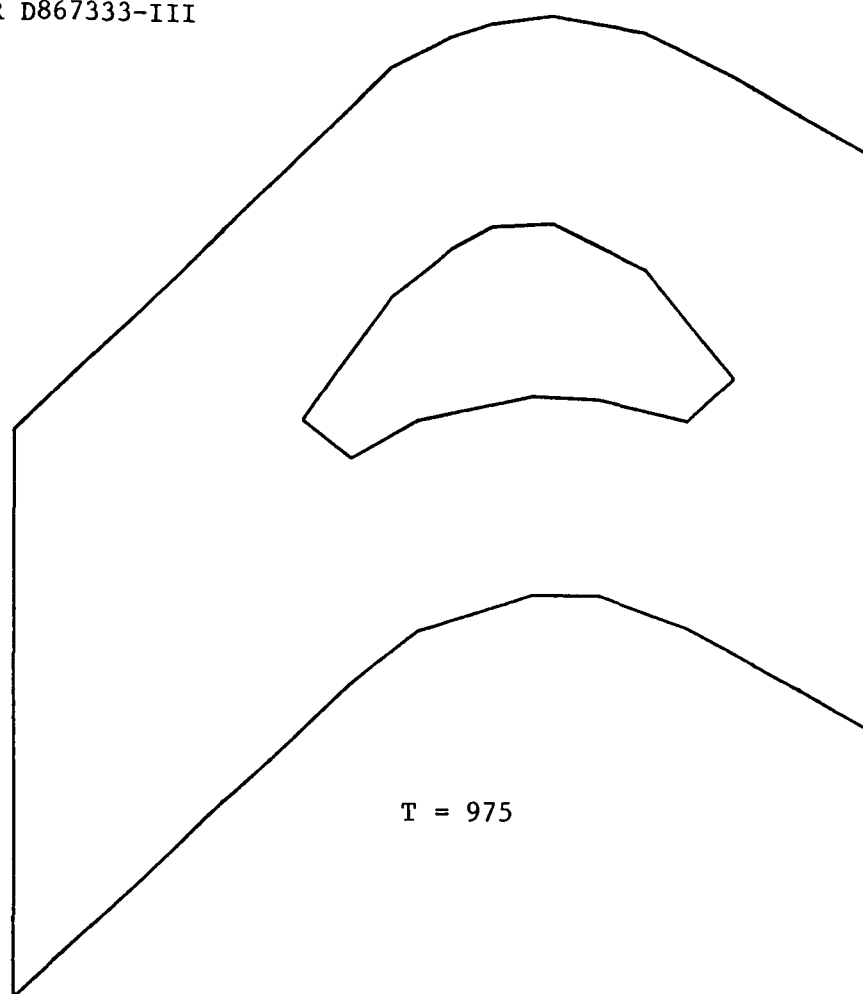

T = 975

1	-3.000000E 02	14	3.500000E 02	27	1.000000E 03
2	-2.500000E 02	15	4.000000E 02	28	1.050000E 03
3	-2.000000E 02	16	4.500000E 02	29	1.100000E 03
4	-1.500000E 02	17	5.000000E 02	30	1.150000E 03
5	-1.000000E 02	18	5.500000E 02	31	1.200000E 03
6	-5.000000E 01	19	6.000000E 02	32	1.250000E 03
7	0.0	20	6.500000E 02	33	1.300000E 03
8	5.000000E 01	21	7.000000E 02	34	1.350000E 03
9	1.000000E 02	22	7.500000E 02	35	1.400000E 03
10	1.500000E 02	23	8.000000E 02	36	1.450000E 03
11	2.000000E 02	24	8.500000E 02	37	1.500000E 03
12	2.500000E 02	25	9.000000E 02	38	1.550000E 03
13	3.000000E 02	26	9.500000E 02	39	1.600000E 03

Fig. 2.4-6 Model 0-1, FPL Load, View 3, Shroud Top Steady State Surface Temperature (F)

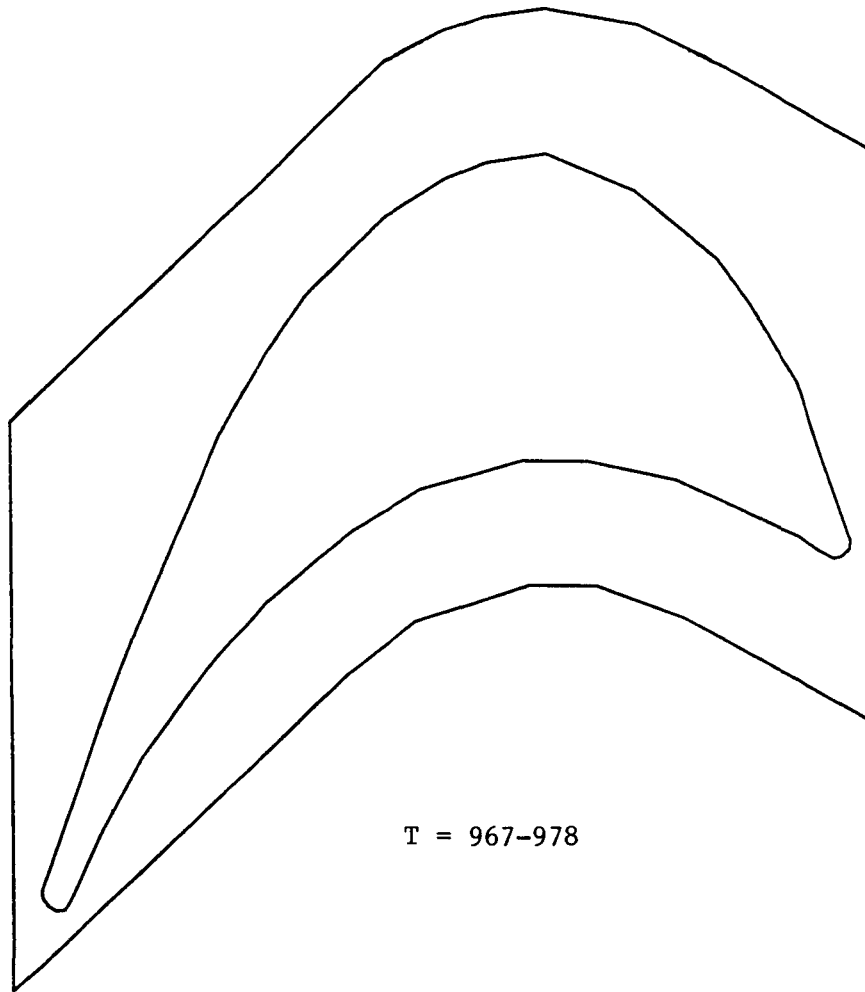

T = 967-978

1	-3.000000E 02	14	3.500000E 02	27	1.000000E 03
2	-2.500000E 02	15	4.000000E 02	28	1.050000E 03
3	-2.000000E 02	16	4.500000E 02	29	1.100000E 03
4	-1.500000E 02	17	5.000000E 02	30	1.150000E 03
5	-1.000000E 02	18	5.500000E 02	31	1.200000E 03
6	-5.000000E 01	19	6.000000E 02	32	1.250000E 03
7	0.0	20	6.500000E 02	33	1.300000E 03
8	5.000000E 01	21	7.000000E 02	34	1.350000E 03
9	1.000000E 02	22	7.500000E 02	35	1.400000E 03
10	1.500000E 02	23	8.000000E 02	36	1.450000E 03
11	2.000000E 02	24	8.500000E 02	37	1.500000E 03
12	2.500000E 02	25	9.000000E 02	38	1.550000E 03
13	3.000000E 02	26	9.500000E 02	39	1.600000E 03

Fig. 2.4-7 Model 0-1, FPL Load, View 3, Shroud Bottom Steady State Surface Temperatures (F)

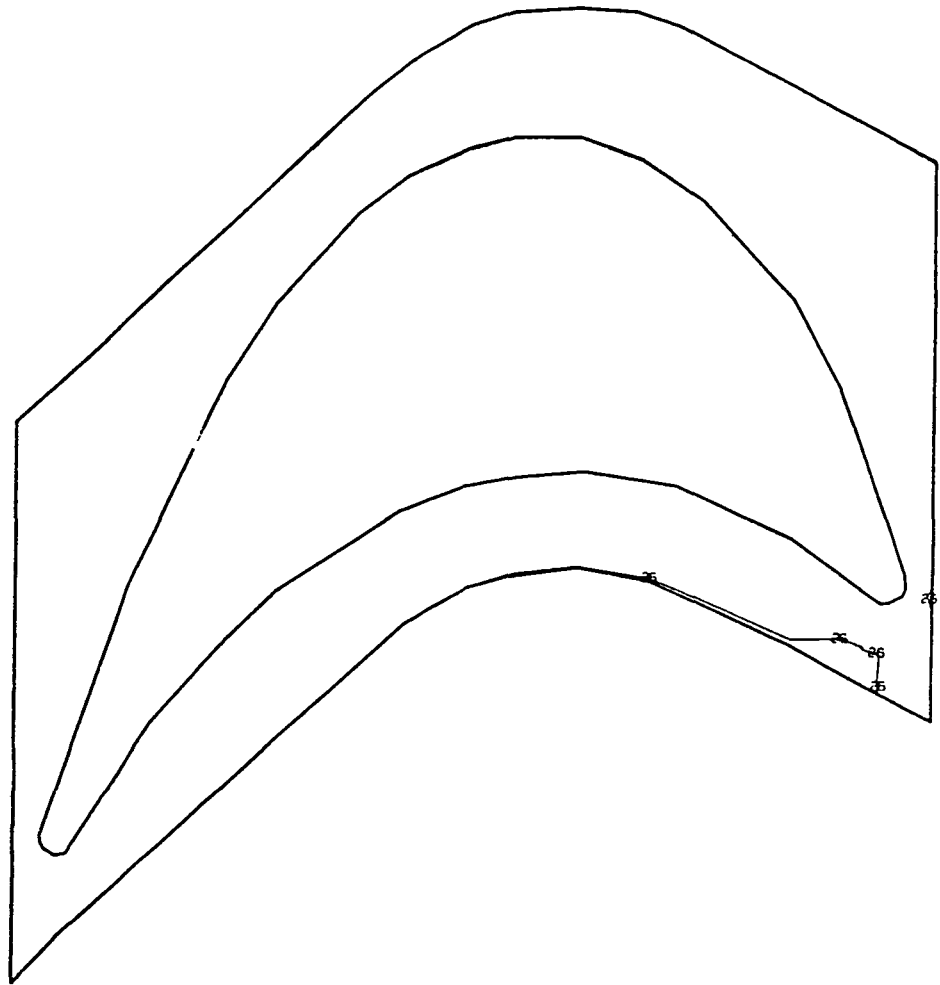

1	-3.000000E 02	14	3.500000E 02	27	1.000000E 03
2	-2.500000E 02	15	4.000000E 02	28	1.050000E 03
3	-2.000000E 02	16	4.500000E 02	29	1.100000E 03
4	-1.500000E 02	17	5.000000E 02	30	1.150000E 03
5	-1.000000E 02	18	5.500000E 02	31	1.200000E 03
6	-5.000000E 01	19	6.000000E 02	32	1.250000E 03
7	0.0	20	6.500000E 02	33	1.300000E 03
8	5.000000E 01	21	7.000000E 02	34	1.350000E 03
9	1.000000E 02	22	7.500000E 02	35	1.400000E 03
10	1.500000E 02	23	8.000000E 02	36	1.450000E 03
11	2.000000E 02	24	8.500000E 02	37	1.500000E 03
12	2.500000E 02	25	9.000000E 02	38	1.550000E 03
13	3.000000E 02	26	9.500000E 02	39	1.600000E 03

Fig. 2.4-8 Model 0-1, FPL Load, View 3, Platform Top Steady State Surface Temperatures (F)

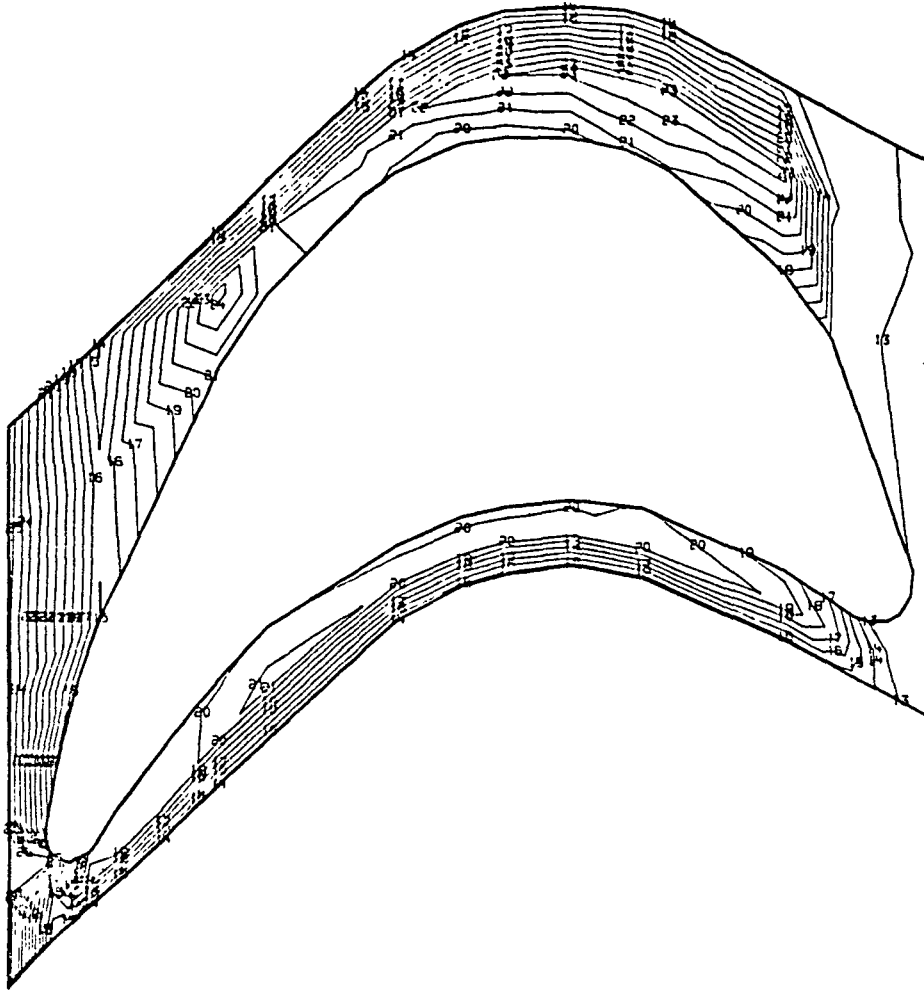

1	-3.000000E 02	14	3.500000E 02	27	1.000000E 03
2	-2.500000E 02	15	4.000000E 02	28	1.050000E 03
3	-2.000000E 02	16	4.500000E 02	29	1.100000E 03
4	-1.500000E 02	17	5.000000E 02	30	1.150000E 03
5	-1.000000E 02	18	5.500000E 02	31	1.200000E 03
6	-5.000000E 01	19	6.000000E 02	32	1.250000E 03
7	0.0	20	6.500000E 02	33	1.300000E 03
8	5.000000E 01	21	7.000000E 02	34	1.350000E 03
9	1.000000E 02	22	7.500000E 02	35	1.400000E 03
10	1.500000E 02	23	8.000000E 02	36	1.450000E 03
11	2.000000E 02	24	8.500000E 02	37	1.500000E 03
12	2.500000E 02	25	9.000000E 02	38	1.550000E 03
13	3.000000E 02	26	9.500000E 02	39	1.600000E 03

Fig. 2.4-9 Model 0-1, FPL Load, View 3, Platform Top Steady State Surface Temperatures (F)

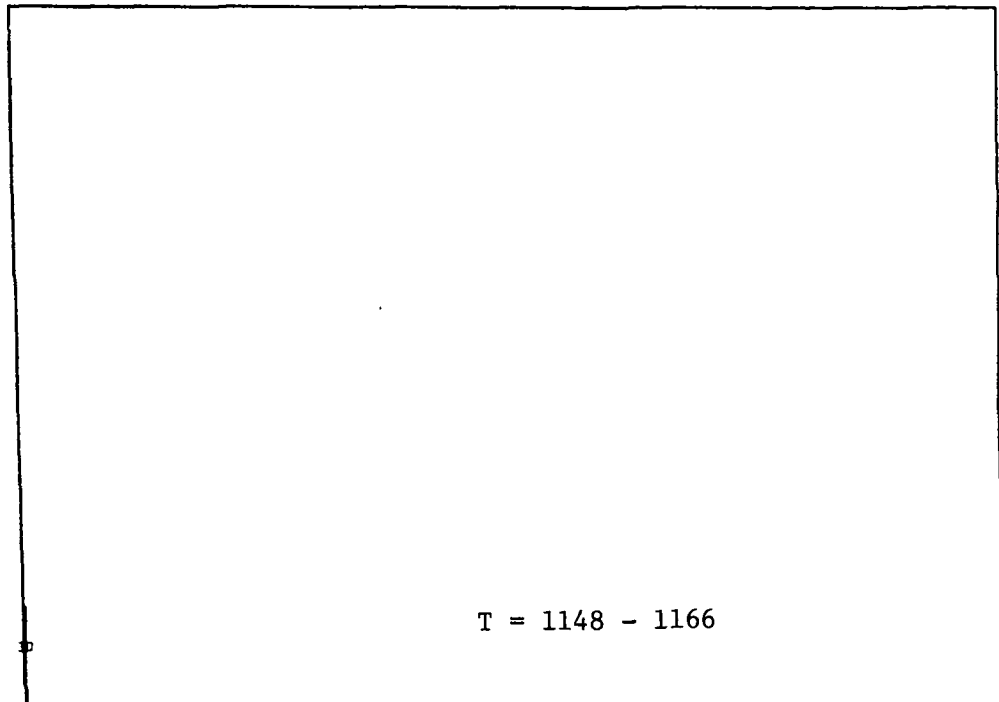

1	-3.000000E 02	14	3.500000E 02	27	1.000000E 03
2	-2.500000E 02	15	4.000000E 02	28	1.050000E 03
3	-2.000000E 02	16	4.500000E 02	29	1.100000E 03
4	-1.500000E 02	17	5.000000E 02	30	1.150000E 03
5	-1.000000E 02	18	5.500000E 02	31	1.200000E 03
6	-5.000000E 01	19	6.000000E 02	32	1.250000E 03
7	0.0	20	6.500000E 02	33	1.300000E 03
8	5.000000E 01	21	7.000000E 02	34	1.350000E 03
9	1.000000E 02	22	7.500000E 02	35	1.400000E 03
10	1.500000E 02	23	8.000000E 02	36	1.450000E 03
11	2.000000E 02	24	8.500000E 02	37	1.500000E 03
12	2.500000E 02	25	9.000000E 02	38	1.550000E 03
13	3.000000E 02	26	9.500000E 02	39	1.600000E 03

Fig. 2.4-10 Model 0-1, FPL Load, View 1, Airfoil Pressure Side Steady State Surface Temperatures (F)

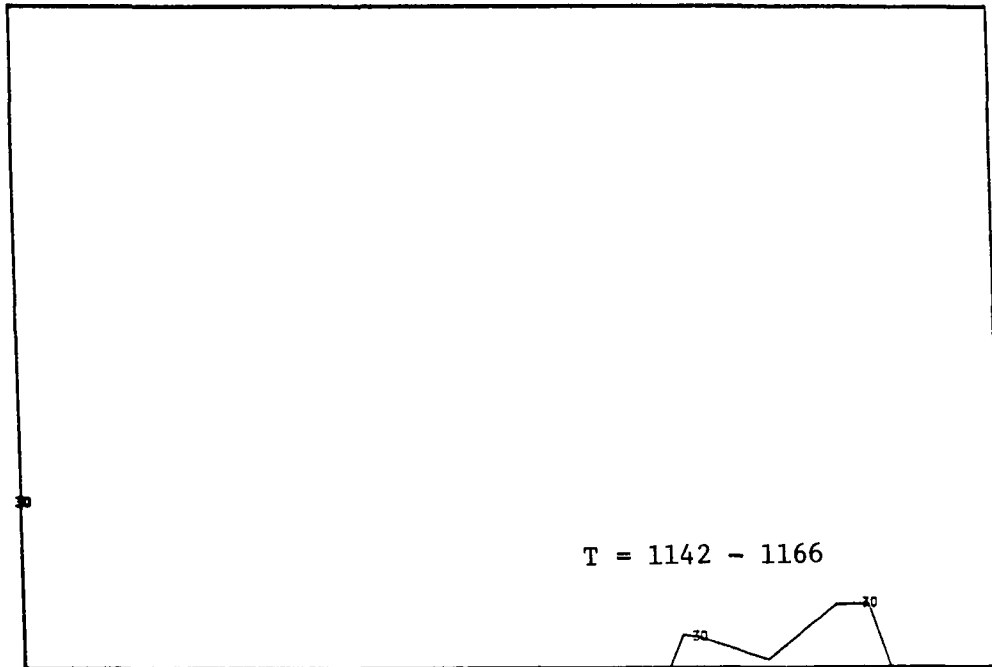

1	-3.000000E 02	14	3.500000E 02	27	1.000000E 03
2	-2.500000E 02	15	4.000000E 02	28	1.050000E 03
3	-2.000000E 02	16	4.500000E 02	29	1.100000E 03
4	-1.500000E 02	17	5.000000E 02	30	1.150000E 03
5	-1.000000E 02	18	5.500000E 02	31	1.200000E 03
6	-5.000000E 01	19	6.000000E 02	32	1.250000E 03
7	0.0	20	6.500000E 02	33	1.300000E 03
8	5.000000E 01	21	7.000000E 02	34	1.350000E 03
9	1.000000E 02	22	7.500000E 02	35	1.400000E 03
10	1.500000E 02	23	8.000000E 02	36	1.450000E 03
11	2.000000E 02	24	8.500000E 02	37	1.500000E 03
12	2.500000E 02	25	9.000000E 02	38	1.550000E 03
13	3.000000E 02	26	9.500000E 02	39	1.600000E 03

Fig. 2.4-11 Model 0-1, 115% Load, View 1, Airfoil Suction Side Steady State Surface Temperatures (F)

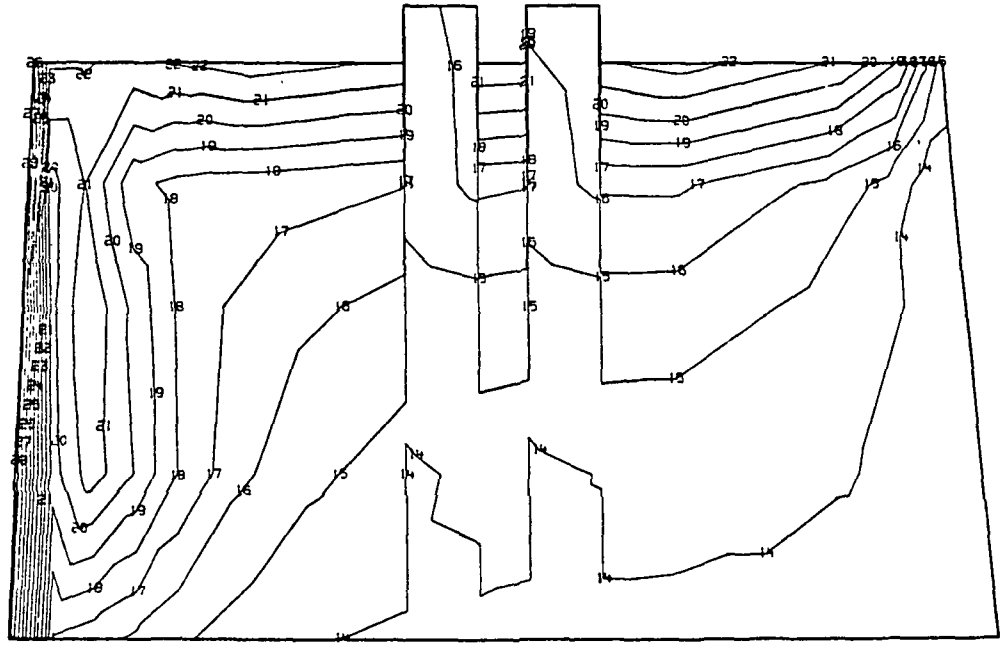

1	-3.000000E 02	14	3.500000E 02	27	1.000000E 03
2	-2.500000E 02	15	4.000000E 02	28	1.050000E 03
3	-2.000000E 02	16	4.500000E 02	29	1.100000E 03
4	-1.500000E 02	17	5.000000E 02	30	1.150000E 03
5	-1.000000E 02	18	5.500000E 02	31	1.200000E 03
6	-5.000000E 01	19	6.000000E 02	32	1.250000E 03
7	0.0	20	6.500000E 02	33	1.300000E 03
8	5.000000E 01	21	7.000000E 02	34	1.350000E 03
9	1.000000E 02	22	7.500000E 02	35	1.400000E 03
10	1.500000E 02	23	8.000000E 02	36	1.450000E 03
11	2.000000E 02	24	8.500000E 02	37	1.500000E 03
12	2.500000E 02	25	9.000000E 02	38	1.550000E 03
13	3.000000E 02	26	9.500000E 02	39	1.600000E 03

Fig. 2.4-12 Model 0-1, 115% Load, View 2, Shank Pressure Side Steady State Surface Temperatures (F)

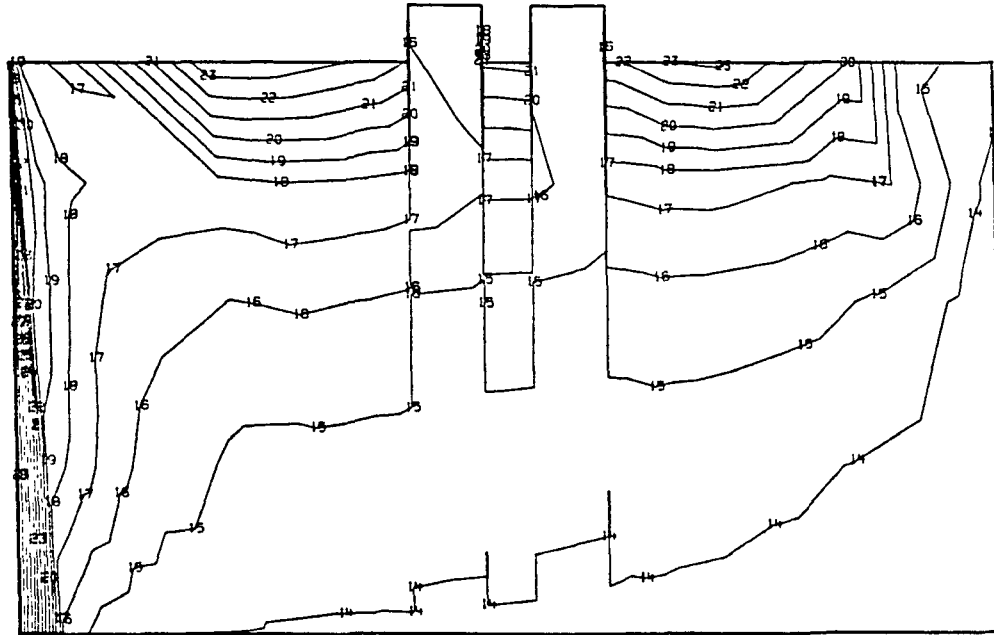

1	-3.000000E 02	14	3.500000E 02	27	1.000000E 03
2	-2.500000E 02	15	4.000000E 02	28	1.050000E 03
3	-2.000000E 02	16	4.500000E 02	29	1.100000E 03
4	-1.500000E 02	17	5.000000E 02	30	1.150000E 03
5	-1.000000E 02	18	5.500000E 02	31	1.200000E 03
6	-5.000000E 01	19	6.000000E 02	32	1.250000E 03
7	0.0	20	6.500000E 02	33	1.300000E 03
8	5.000000E 01	21	7.000000E 02	34	1.350000E 03
9	1.000000E 02	22	7.500000E 02	35	1.400000E 03
10	1.500000E 02	23	8.000000E 02	36	1.450000E 03
11	2.000000E 02	24	8.500000E 02	37	1.500000E 03
12	2.500000E 02	25	9.000000E 02	38	1.550000E 03
13	3.000000E 02	26	9.500000E 02	39	1.600000E 03

Fig. 2.4-13 Model 0-1, 115% Load, View 2, Shank Suction Steady State Surface Temperatures (F)

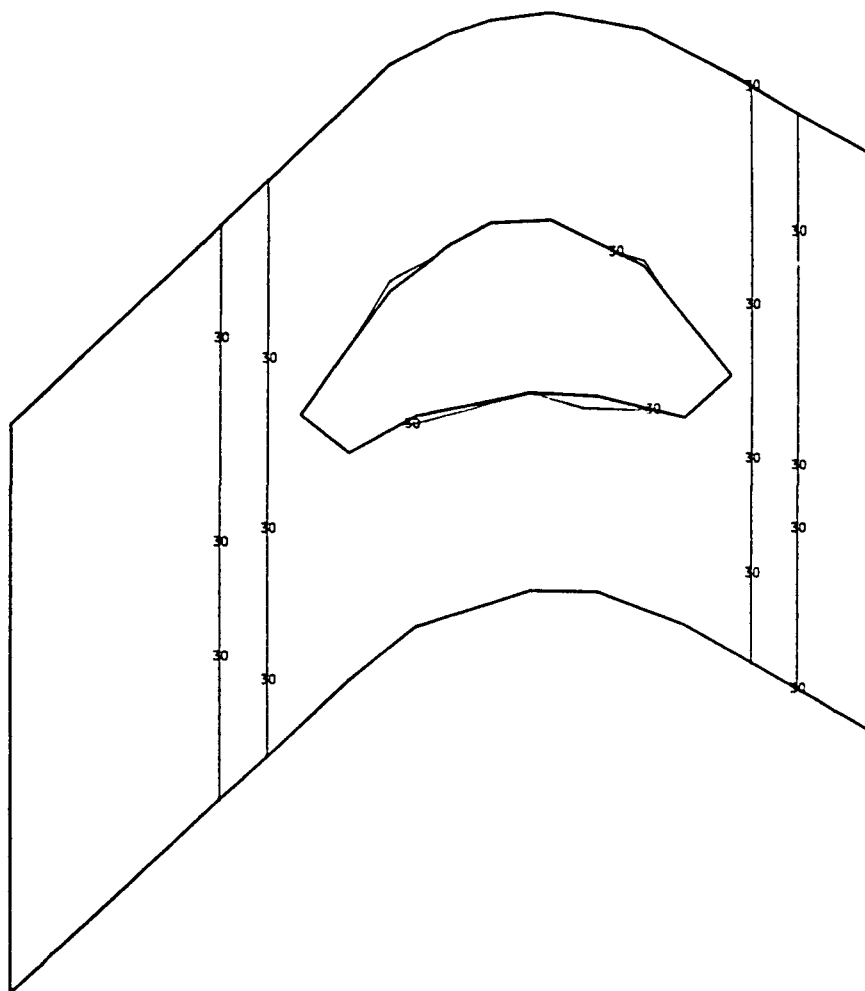

1	-3.000000E 02	14	3.500000E 02	27	1.000000E 03
2	-2.500000E 02	15	4.000000E 02	28	1.050000E 03
3	-2.000000E 02	16	4.500000E 02	29	1.100000E 03
4	-1.500000E 02	17	5.000000E 02	30	1.150000E 03
5	-1.000000E 02	18	5.500000E 02	31	1.200000E 03
6	-5.000000E 01	19	6.000000E 02	32	1.250000E 03
7	0.0	20	6.500000E 02	33	1.300000E 03
8	5.000000E 01	21	7.000000E 02	34	1.350000E 03
9	1.000000E 02	22	7.500000E 02	35	1.400000E 03
10	1.500000E 02	23	8.000000E 02	36	1.450000E 03
11	2.000000E 02	24	8.500000E 02	37	1.500000E 03
12	2.500000E 02	25	9.000000E 02	38	1.550000E 03
13	3.000000E 02	26	9.500000E 02	39	1.600000E 03

Fig. 2.4-14 Model 0-1, 115% Load, View 3, Shroud Top Steady State Surface Temperatures' (F)

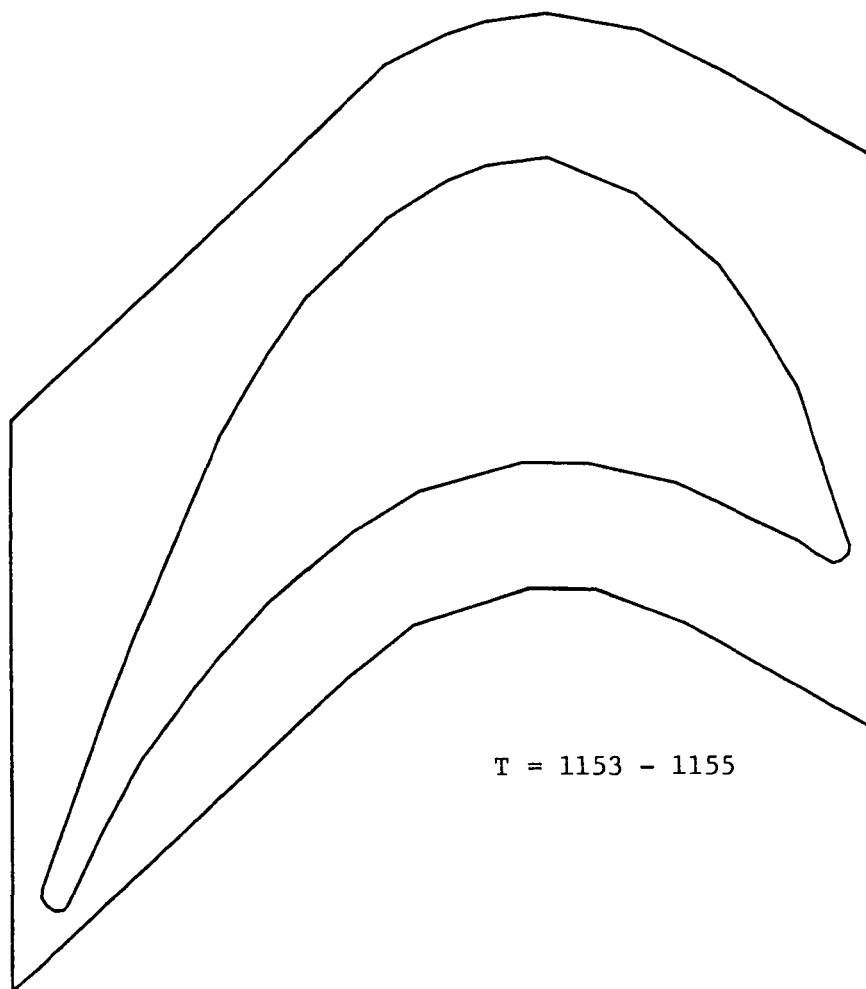

T = 1153 - 1155

1	-3.000000E 02	14	3.500000E 02	27	1.000000E 03
2	-2.500000E 02	15	4.000000E 02	28	1.050000E 03
3	-2.000000E 02	16	4.500000E 02	29	1.100000E 03
4	-1.500000E 02	17	5.000000E 02	30	1.150000E 03
5	-1.000000E 02	18	5.500000E 02	31	1.200000E 03
6	-5.000000E 01	19	6.000000E 02	32	1.250000E 03
7	0.0	20	6.500000E 02	33	1.300000E 03
8	5.000000E 01	21	7.000000E 02	34	1.350000E 03
9	1.000000E 02	22	7.500000E 02	35	1.400000E 03
10	1.500000E 02	23	8.000000E 02	36	1.450000E 03
11	2.000000E 02	24	8.500000E 02	37	1.500000E 03
12	2.500000E 02	25	9.000000E 02	38	1.550000E 03
13	3.000000E 02	26	9.500000E 02	39	1.600000E 03

Fig. 2.4-15 Model 0-1, 115% Load, View 3, Shroud Bottom Steady State Surface Temperatures (F)

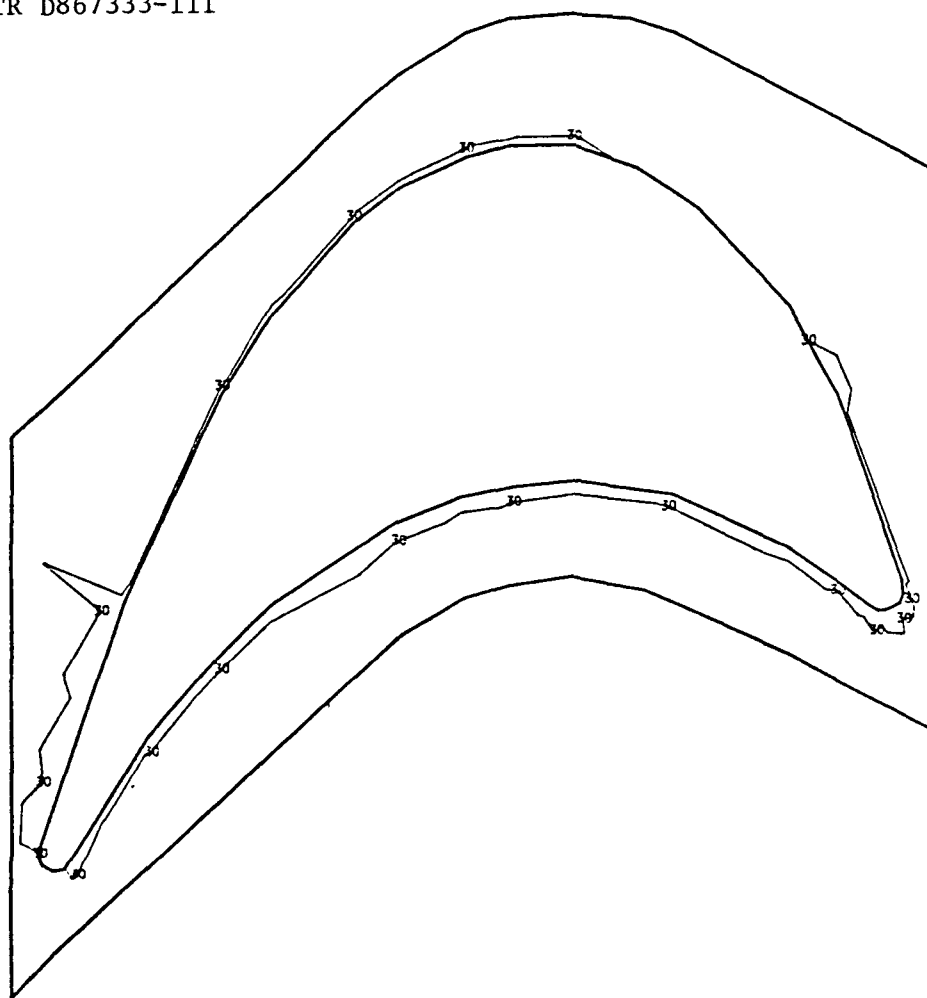

1	-3.000000E 02	14	3.500000E 02	27	1.000000E 03
2	-2.500000E 02	15	4.000000E 02	28	1.050000E 03
3	-2.000000E 02	16	4.500000E 02	29	1.100000E 03
4	-1.500000E 02	17	5.000000E 02	30	1.150000E 03
5	-1.000000E 02	18	5.500000E 02	31	1.200000E 03
6	-5.000000E 01	19	6.000000E 02	32	1.250000E 03
7	0.0	20	6.500000E 02	33	1.300000E 03
8	5.000000E 01	21	7.000000E 02	34	1.350000E 03
9	1.000000E 02	22	7.500000E 02	35	1.400000E 03
10	1.500000E 02	23	8.000000E 02	36	1.450000E 03
11	2.000000E 02	24	8.500000E 02	37	1.500000E 03
12	2.500000E 02	25	9.000000E 02	38	1.550000E 03
13	3.000000E 02	26	9.500000E 02	39	1.600000E 03

Fig. 2.4-16 Model 0-1, 115% Load, View 3, Platform Top Steady State Surface Temperatures (F)

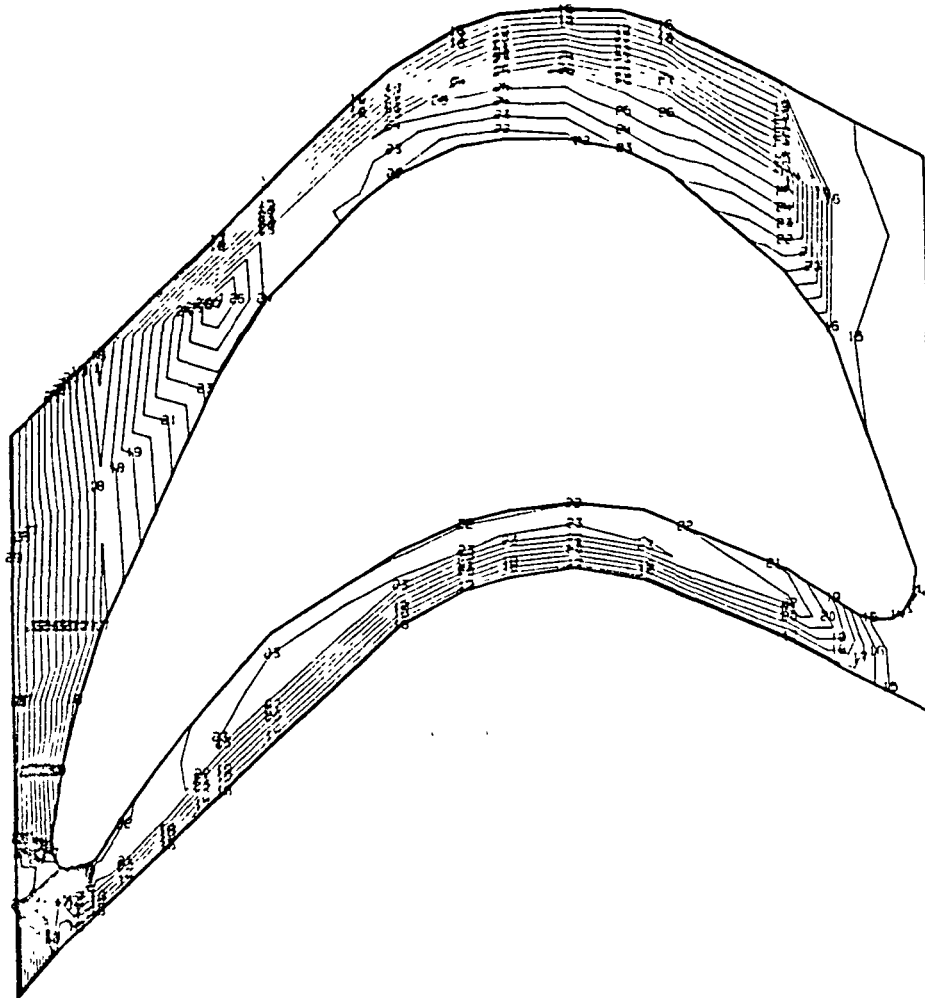

1	-3.000000E 02	14	3.500000E 02	27	1.000000E 03
2	-2.500000E 02	15	4.000000E 02	28	1.050000E 03
3	-2.000000E 02	16	4.500000E 02	29	1.100000E 03
4	-1.500000E 02	17	5.000000E 02	30	1.150000E 03
5	-1.000000E 02	18	5.500000E 02	31	1.200000E 03
6	-5.000000E 01	19	6.000000E 02	32	1.250000E 03
7	0.0	20	6.500000E 02	33	1.300000E 03
8	5.000000E 01	21	7.000000E 02	34	1.350000E 03
9	1.000000E 02	22	7.500000E 02	35	1.400000E 03
10	1.500000E 02	23	8.000000E 02	36	1.450000E 03
11	2.000000E 02	24	8.500000E 02	37	1.500000E 03
12	2.500000E 02	25	9.000000E 02	38	1.550000E 03
13	3.000000E 02	26	9.500000E 02	39	1.600000E 03

Fig. 2.4-17 Model 0-1, 115% Load, View 3, Platform Bottom Steady State Surface Temperatures (F)

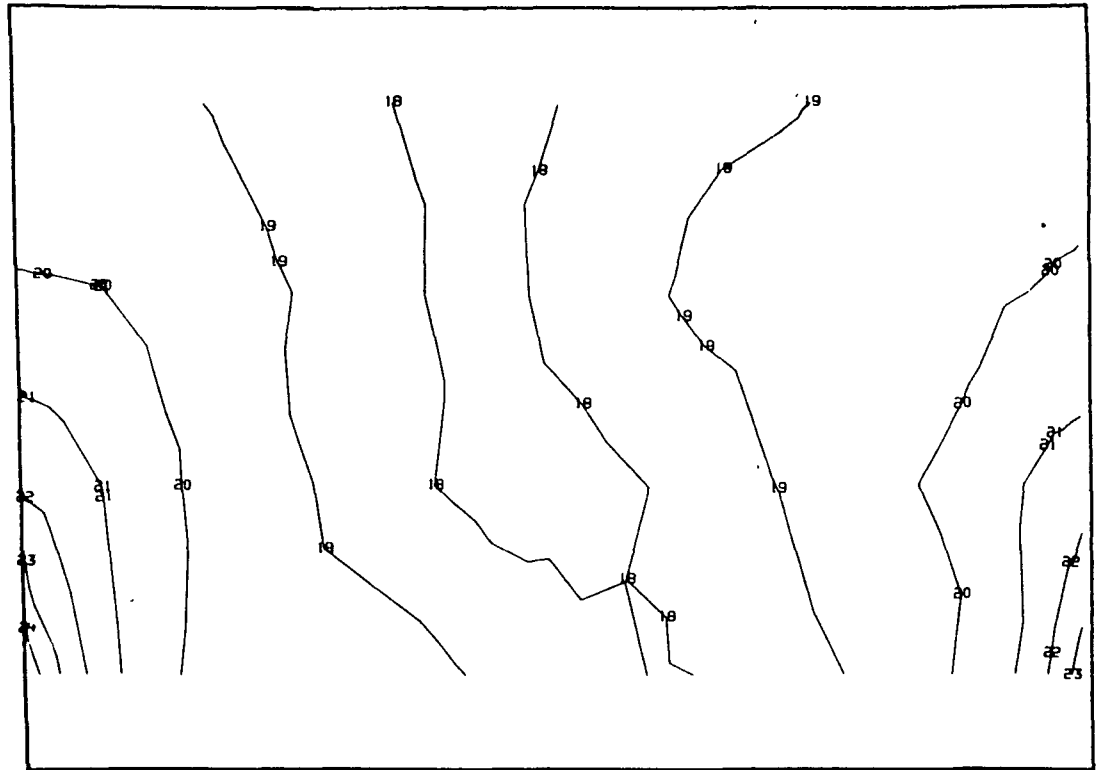

1	-1.500000E 05	12	-4.000000E 04	23	5.000000E 04
2	-1.400000E 05	13	-3.000000E 04	24	6.000000E 04
3	-1.300000E 05	14	-2.000000E 04	25	7.000000E 04
4	-1.200000E 05	15	-1.000000E 04	26	8.000000E 04
5	-1.100000E 05	16	-5.000000E 03	27	9.000000E 04
6	-1.000000E 05	17	0.0	28	1.000000E 05
7	-9.000000E 04	18	5.000000E 03	29	1.100000E 05
8	-8.000000E 04	19	1.000000E 04	30	1.200000E 05
9	-7.000000E 04	20	2.000000E 04	31	1.300000E 05
10	-6.000000E 04	21	3.000000E 04	32	1.400000E 05
11	-5.000000E 04	22	4.000000E 04	33	1.500000E 05

Fig. 2.4-18 Model 0-1, FPL Load, View 1, Airfoil Pressure Side Major Principal Stress (psi)

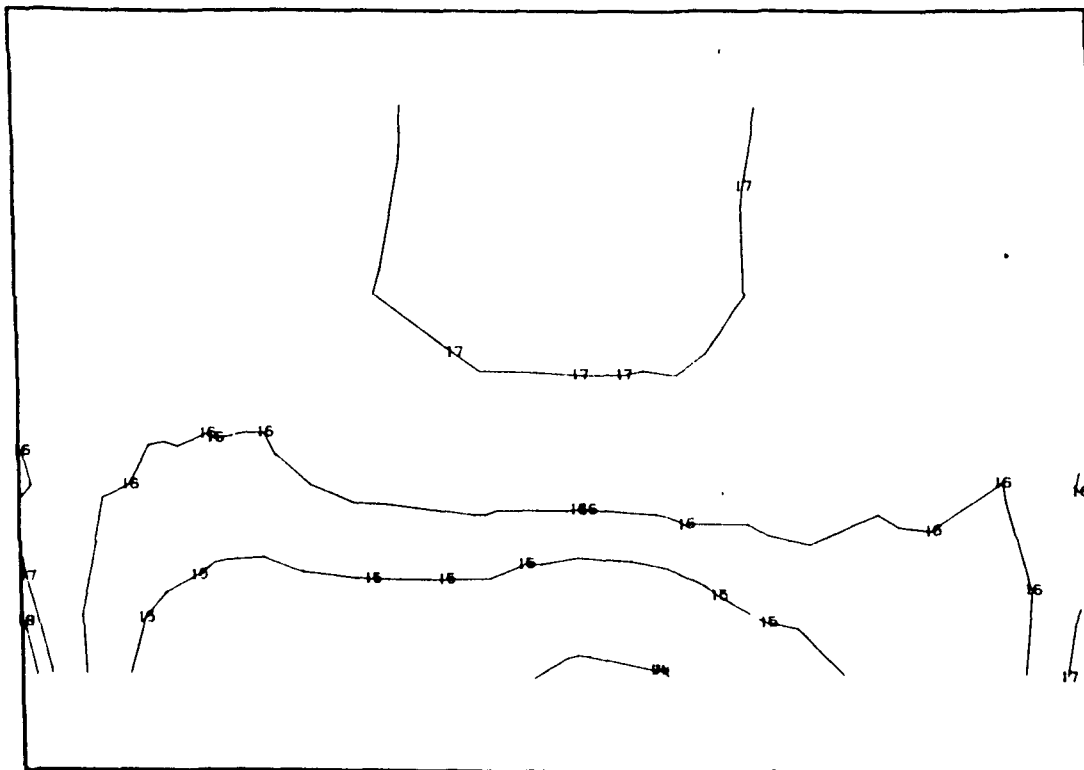

1	-1.500000E 05	12	-4.000000E 04	23	5.000000E 04
2	-1.400000E 05	13	-3.000000E 04	24	6.000000E 04
3	-1.300000E 05	14	-2.000000E 04	25	7.000000E 04
4	-1.200000E 05	15	-1.000000E 04	26	8.000000E 04
5	-1.100000E 05	16	-5.000000E 03	27	9.000000E 04
6	-1.000000E 05	17	0.0	28	1.000000E 05
7	-9.000000E 04	18	5.000000E 03	29	1.100000E 05
8	-8.000000E 04	19	1.000000E 04	30	1.200000E 05
9	-7.000000E 04	20	2.000000E 04	31	1.300000E 05
10	-6.000000E 04	21	3.000000E 04	32	1.400000E 05
11	-5.000000E 04	22	4.000000E 04	33	1.500000E 05

Fig. 2.4-19 Model 0-1, FPL Load, View 1, Airfoil Pressure Side Minor Principal Stress (psi)

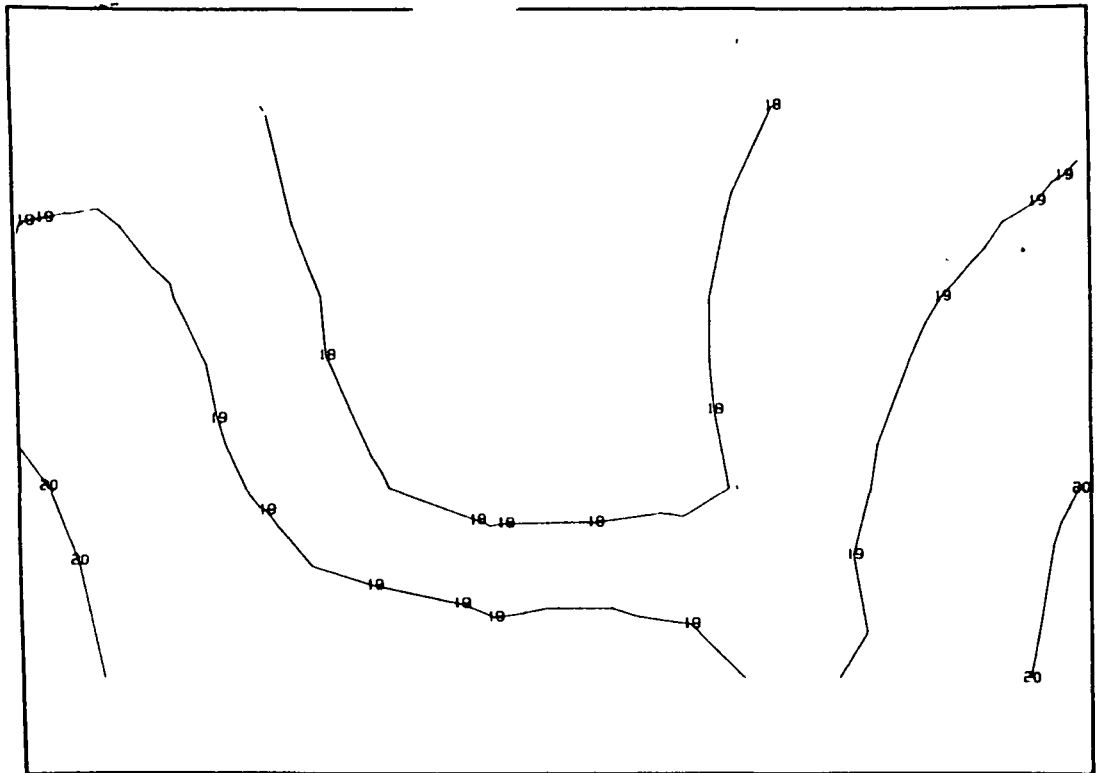

1	-1.500000E 05	05	12	-4.000000E 04	04	23	5.000000E 04
2	-1.400000E 05	05	13	-3.000000E 04	04	24	6.000000E 04
3	-1.300000E 05	05	14	-2.000000E 04	04	25	7.000000E 04
4	-1.200000E 05	05	15	-1.000000E 04	04	26	8.000000E 04
5	-1.100000E 05	05	16	-5.000000E 03	03	27	9.000000E 04
6	-1.000000E 05	05	17	0.0		28	1.000000E 04
7	-9.000000E 04	04	18	5.000000E 03	03	29	1.100000E 04
8	-8.000000E 04	04	19	1.000000E 04	04	30	1.200000E 04
9	-7.000000E 04	04	20	2.000000E 04	04	31	1.300000E 04
10	-6.000000E 04	04	21	3.000000E 04	04	32	1.400000E 04
11	-5.000000E 04	04	22	4.000000E 04	04	33	1.500000E 04

Fig. 2.4-20 Model 0-1, FPL Load, View 1, Airfoil Pressure Side Maximum Principal Shear (psi)

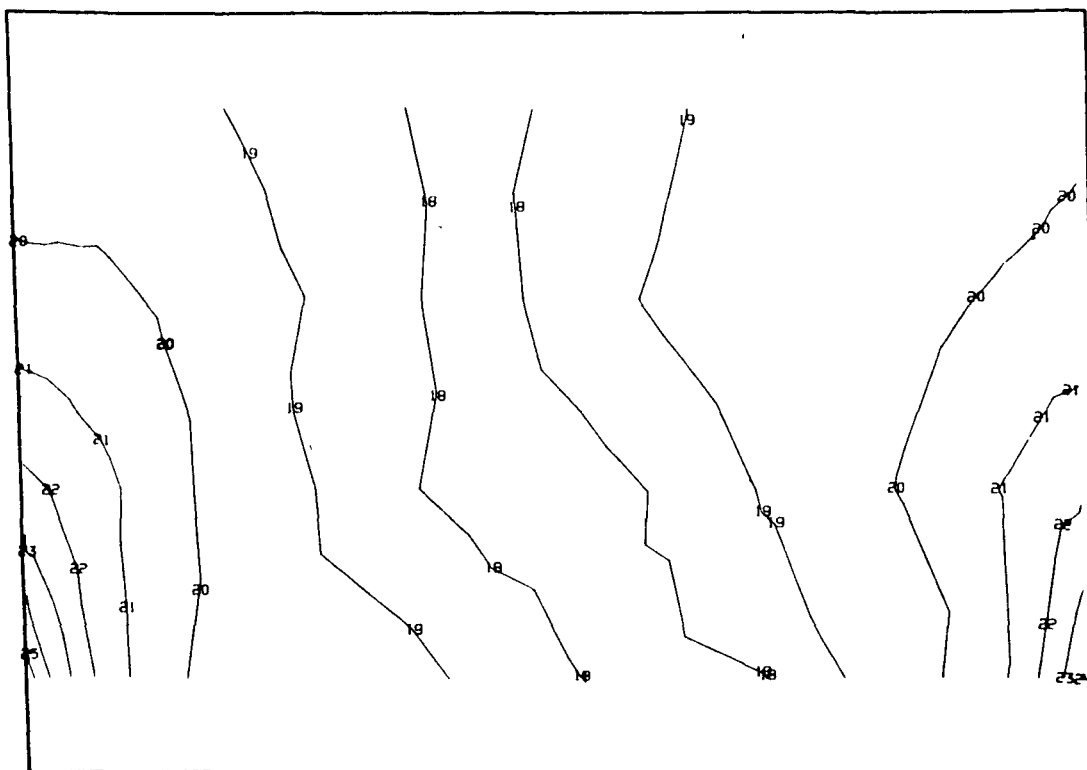

1	-1.500000E 05	12	-4.000000E 04	23	5.000000E 04
2	-1.400000E 05	13	-3.000000E 04	24	6.000000E 04
3	-1.300000E 05	14	-2.000000E 04	25	7.000000E 04
4	-1.200000E 05	15	-1.000000E 04	26	8.000000E 04
5	-1.100000E 05	16	-5.000000E 03	27	9.000000E 04
6	-1.000000E 05	17	0.0	28	1.000000E 05
7	-9.000000E 04	18	5.000000E 03	29	1.100000E 05
8	-8.000000E 04	19	1.000000E 04	30	1.200000E 05
9	-7.000000E 04	20	2.000000E 04	31	1.300000E 05
10	-6.000000E 04	21	3.000000E 04	32	1.400000E 05
11	-5.000000E 04	22	4.000000E 04	33	1.500000E 05

Fig. 2.4-21 Model 0-1, FPL Load, View 1, Airfoil Pressure Side Major Principal Stress (psi)

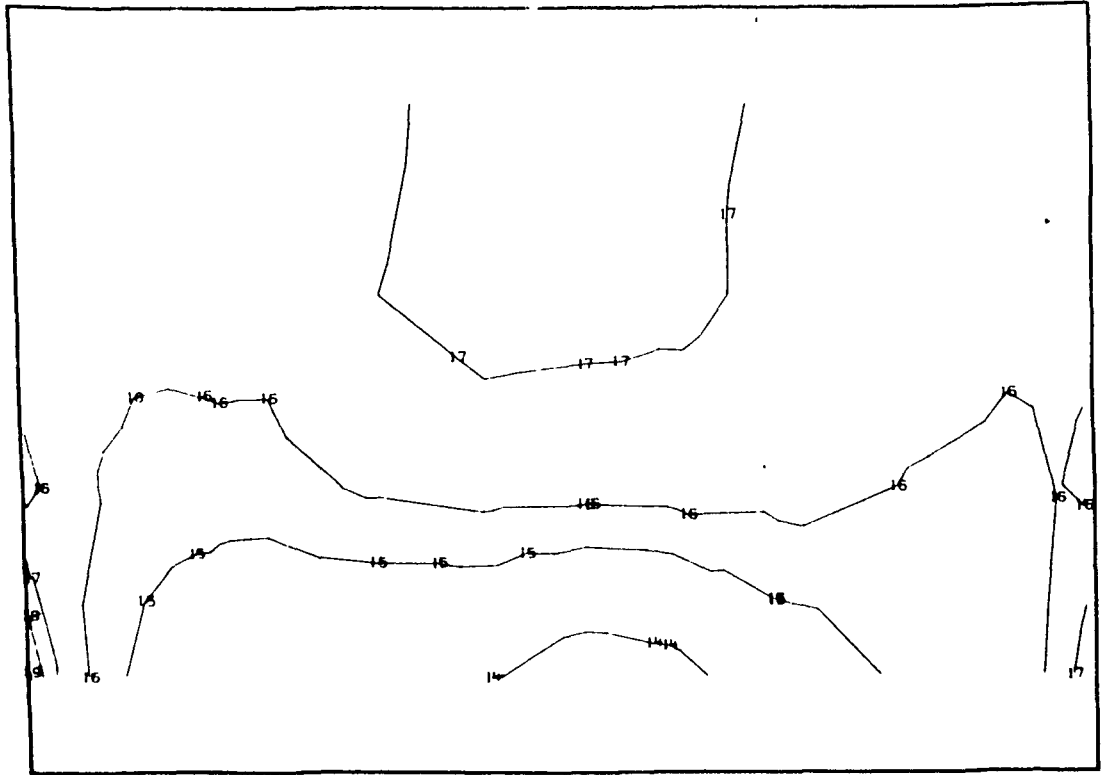

1	-1.500000E 05	12	-4.000000E 04	23	5.000000E 04
2	-1.400000E 05	13	-3.000000E 04	24	6.000000E 04
3	-1.300000E 05	14	-2.000000E 04	25	7.000000E 04
4	-1.200000E 05	15	-1.000000E 04	26	8.000000E 04
5	-1.100000E 05	16	-5.000000E 03	27	9.000000E 04
6	-1.000000E 05	17	0.0	28	1.000000E 05
7	-9.000000E 04	18	5.000000E 03	29	1.100000E 05
8	-8.000000E 04	19	1.000000E 04	30	1.200000E 05
9	-7.000000E 04	20	2.000000E 04	31	1.300000E 05
10	-6.000000E 04	21	3.000000E 04	32	1.400000E 05
11	-5.000000E 04	22	4.000000E 04	33	1.500000E 05

Fig. 2.4-22 Model 0-1, 115% Load, View 1, Airfoil Pressure Side Minor Principal Stress (psi)

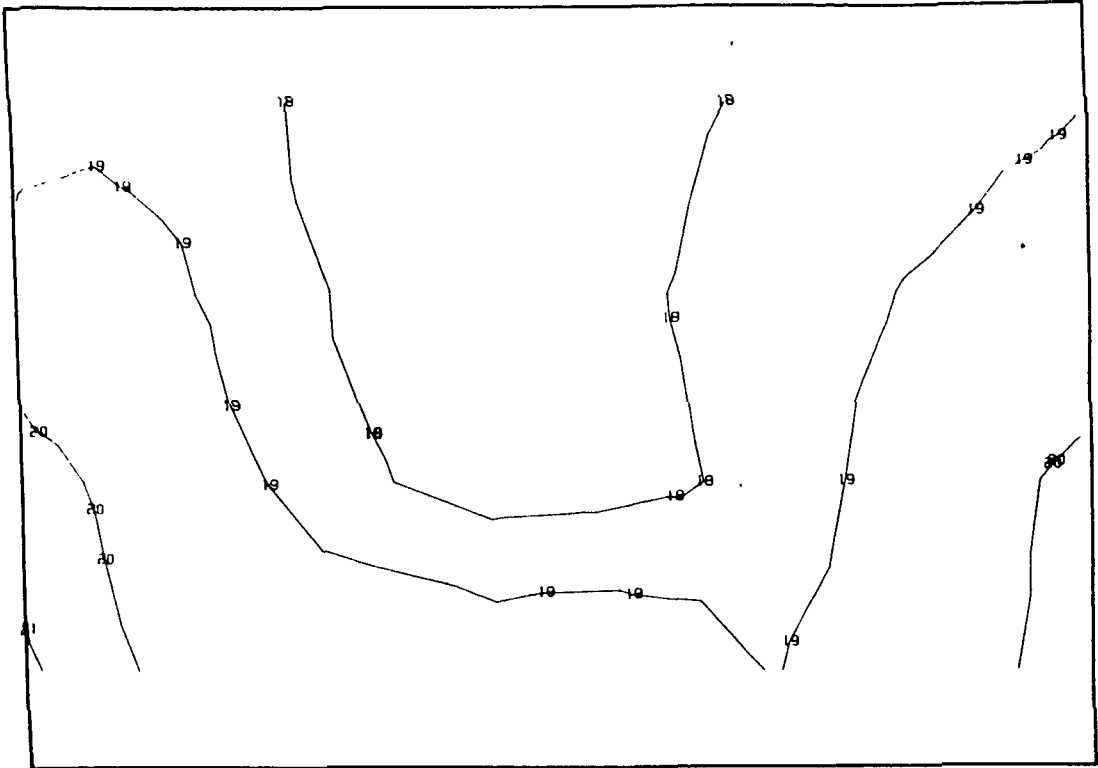

1	-1.500000E 05	12	-4.000000E 04	23	5.000000E 04
2	-1.400000E 05	13	-3.000000E 04	24	6.000000E 04
3	-1.300000E 05	14	-2.000000E 04	25	7.000000E 04
4	-1.200000E 05	15	-1.000000E 04	26	8.000000E 04
5	-1.100000E 05	16	-5.000000E 03	27	9.000000E 04
6	-1.000000E 05	17	0.0	28	1.000000E 05
7	-9.000000E 04	18	5.000000E 03	29	1.100000E 05
8	-8.000000E 04	19	1.000000E 04	30	1.200000E 05
9	-7.000000E 04	20	2.000000E 04	31	1.300000E 05
10	-6.000000E 04	21	3.000000E 04	32	1.400000E 05
11	-5.000000E 04	22	4.000000E 04	33	1.500000E 05

Fig. 2.4-23 Model 0-1, FPL Load, View 1, Airfoil Pressure Side Maximum Principal Shear (psi)

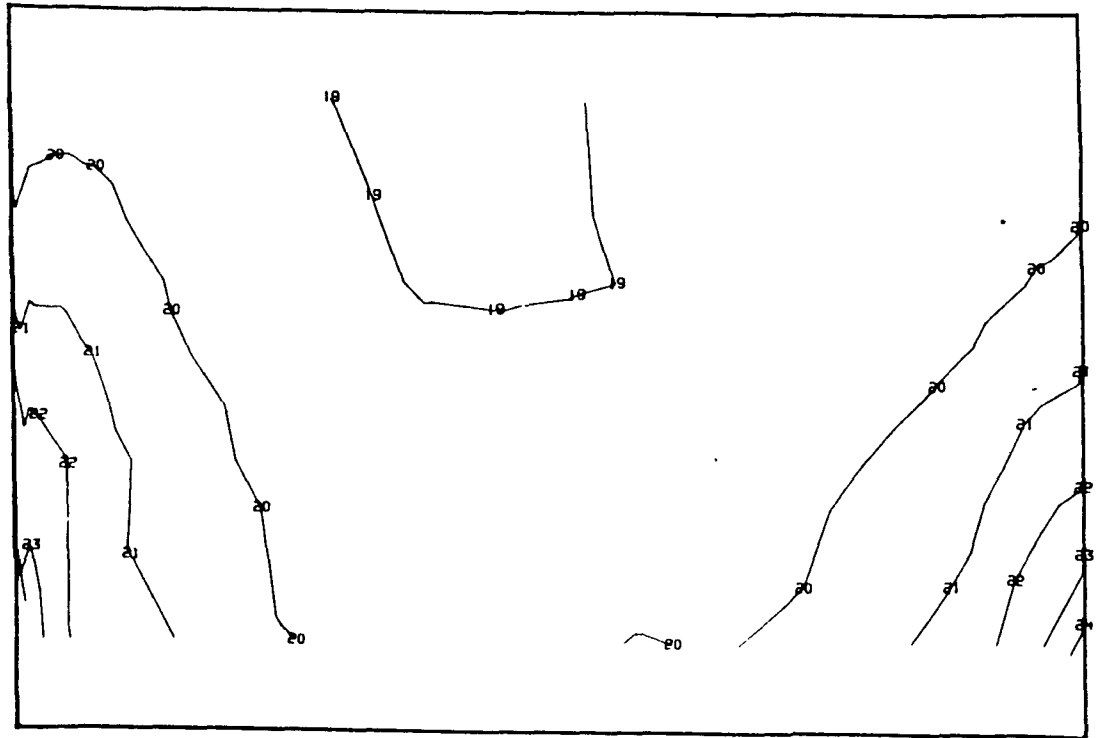

1	-1.500000E 05	05	12	-4.000000E 04	04	23	5.000000E 04	04
2	-1.400000E 05	05	13	-3.000000E 04	04	24	6.000000E 04	04
3	-1.300000E 05	05	14	-2.000000E 04	04	25	7.000000E 04	04
4	-1.200000E 05	05	15	-1.000000E 04	04	26	8.000000E 04	04
5	-1.100000E 05	05	16	-5.000000E 03	03	27	9.000000E 04	04
6	-1.000000E 05	05	17	0.0		28	1.000000E 05	05
7	-9.000000E 04	04	18	5.000000E 03	03	29	1.100000E 05	05
8	-8.000000E 04	04	19	1.000000E 04	04	30	1.200000E 05	05
9	-7.000000E 04	04	20	2.000000E 04	04	31	1.300000E 05	05
10	-6.000000E 04	04	21	3.000000E 04	04	32	1.400000E 05	05
11	-5.000000E 04	04	22	4.000000E 04	04	33	1.500000E 05	05

Fig. 2.4-24 Model 0-1, 115% Load, View 1, Airfoil Suction Side Major Principal Stress (psi)

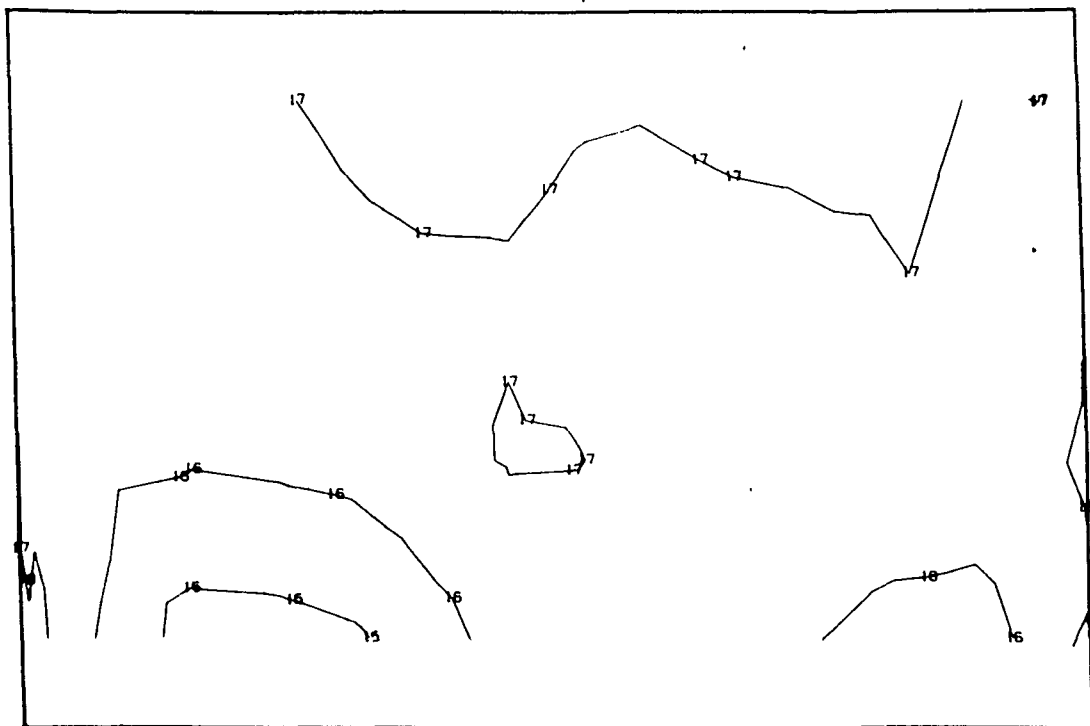

1	-1.500000E 05		12	-4.000000E 04		23	5.000000E 04
2	-1.400000E 05		13	-3.000000E 04		24	6.000000E 04
3	-1.300000E 05		14	-2.000000E 04		25	7.000000E 04
4	-1.200000E 05		15	-1.000000E 04		26	8.000000E 04
5	-1.100000E 05		16	-5.000000E 03		27	9.000000E 04
6	-1.000000E 05		17	0.0		28	1.000000E 05
7	-9.000000E 04		18	5.000000E 03		29	1.100000E 05
8	-8.000000E 04		19	1.000000E 04		30	1.200000E 05
9	-7.000000E 04		20	2.000000E 04		31	1.300000E 05
10	-6.000000E 04		21	3.000000E 04		32	1.400000E 05
11	-5.000000E 04		22	4.000000E 04		33	1.500000E 05

Fig. 2.4-25 Model 0-1, 115% Load, View L, Airfoil Suction Side Minor Principal Stress (psi)

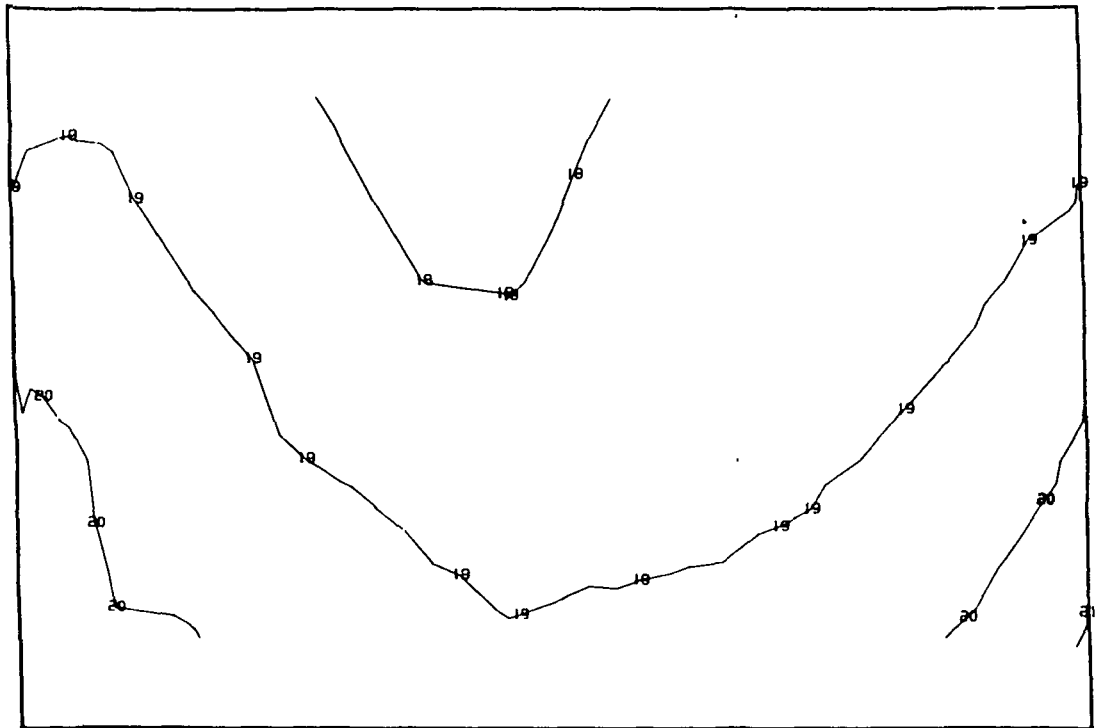

1	-1.500000E 05	12	-4.000000E 04	23	5.000000E 04
2	-1.400000E 05	13	-3.000000E 04	24	6.000000E 04
3	-1.300000E 05	14	-2.000000E 04	25	7.000000E 04
4	-1.200000E 05	15	-1.000000E 04	26	8.000000E 04
5	-1.100000E 05	16	-5.000000E 03	27	9.000000E 04
6	-1.000000E 05	17	0.0	28	1.000000E 05
7	-9.000000E 04	18	5.000000E 03	29	1.100000E 05
8	-8.000000E 04	19	1.000000E 04	30	1.200000E 05
9	-7.000000E 04	20	2.000000E 04	31	1.300000E 05
10	-6.000000E 04	21	3.000000E 04	32	1.400000E 05
11	-5.000000E 04	22	4.000000E 04	33	1.500000E 05

Fig. 2.4-26 Model 0-1, FPL Load, View 1, Airfoil Suction Side Maximum Principal Shear (psi)

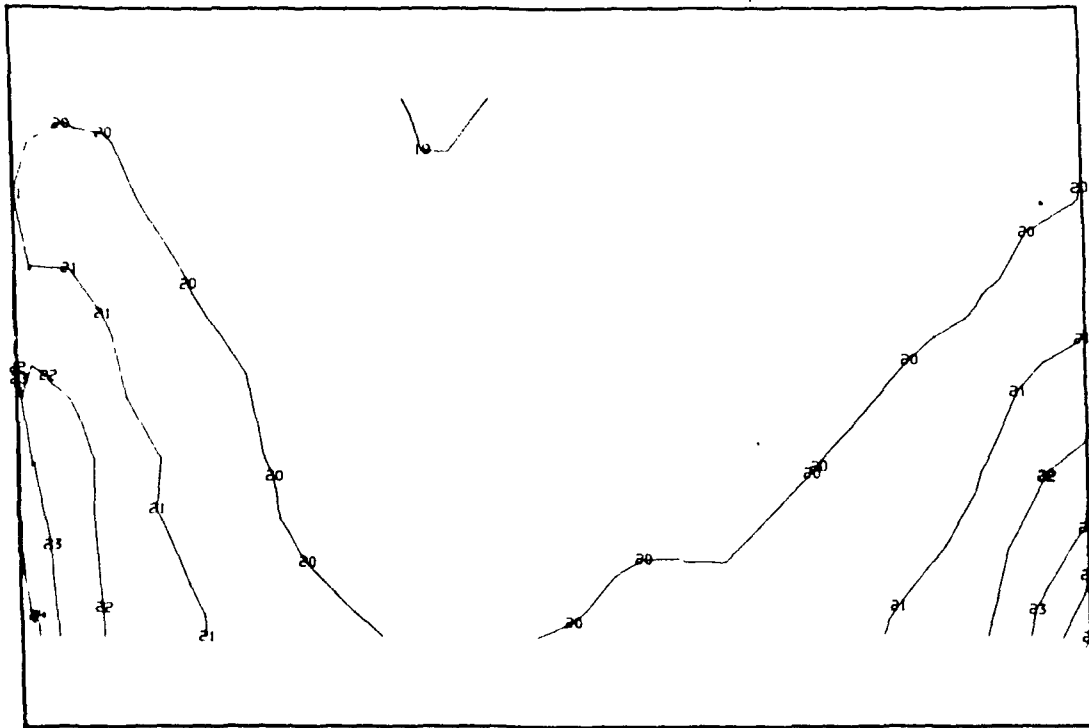

1	-1.500000E 05	12	-4.000000E 04	23	5.000000E 04
2	-1.400000E 05	13	-3.000000E 04	24	6.000000E 04
3	-1.300000E 05	14	-2.000000E 04	25	7.000000E 04
4	-1.200000E 05	15	-1.000000E 04	26	8.000000E 04
5	-1.100000E 05	16	-5.000000E 03	27	9.000000E 04
6	-1.000000E 05	17	0.0	28	1.000000E 05
7	-9.000000E 04	18	5.000000E 03	29	1.100000E 05
8	-8.000000E 04	19	1.000000E 04	30	1.200000E 05
9	-7.000000E 04	20	2.000000E 04	31	1.300000E 05
10	-6.000000E 04	21	3.000000E 04	32	1.400000E 05
11	-5.000000E 04	22	4.000000E 04	33	1.500000E 05

Fig. 2.4-27 Model 0-1, 115% Load, View 1, Airfoil Suction Side Major Principal Stress (psi)

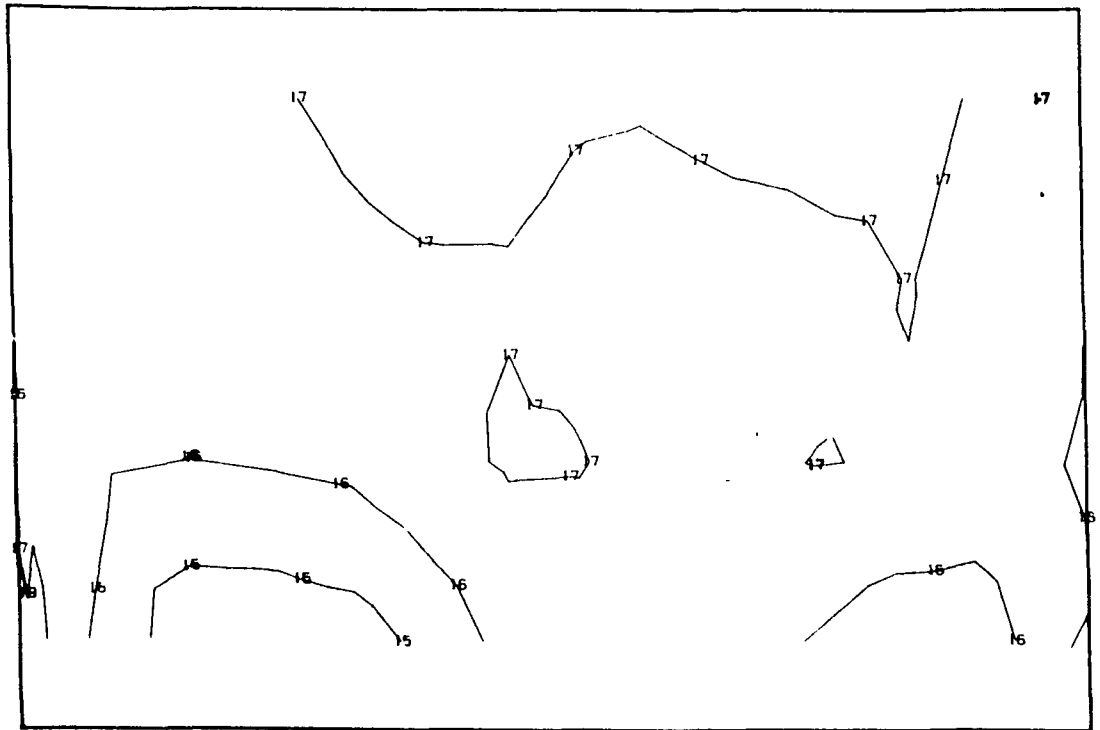

1	-1.500000E 05	12	-4.000000E 04	23	5.000000E 04
2	-1.400000E 05	13	-3.000000E 04	24	6.000000E 04
3	-1.300000E 05	14	-2.000000E 04	25	7.000000E 04
4	-1.200000E 05	15	-1.000000E 04	26	8.000000E 04
5	-1.100000E 05	16	-5.000000E 03	27	9.000000E 04
6	-1.000000E 05	17	0.0	28	1.000000E 05
7	-9.000000E 04	18	5.000000E 03	29	1.100000E 05
8	-8.000000E 04	19	1.000000E 04	30	1.200000E 05
9	-7.000000E 04	20	2.000000E 04	31	1.300000E 05
10	-6.000000E 04	21	3.000000E 04	32	1.400000E 05
11	-5.000000E 04	22	4.000000E 04	33	1.500000E 05

Fig. 2.4-28 Model 0-1, 115% Load, View 1, Airfoil Suction Side Minor Principal Stress (psi)

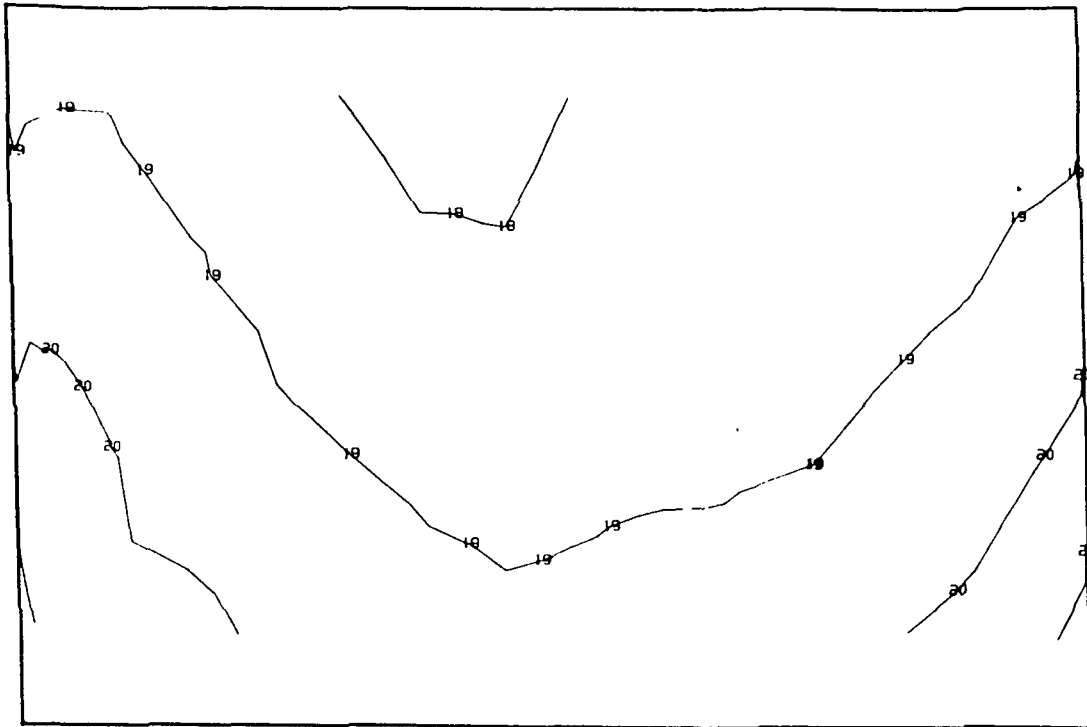

1	-1.500000E 05	12	-4.000000E 04	23	5.000000E 04
2	-1.400000E 05	13	-3.000000E 04	24	6.000000E 04
3	-1.300000E 05	14	-2.000000E 04	25	7.000000E 04
4	-1.200000E 05	15	-1.000000E 04	26	8.000000E 04
5	-1.100000E 05	16	-5.000000E 03	27	9.000000E 04
6	-1.000000E 05	17	0.0	28	1.000000E 05
7	-9.000000E 04	18	5.000000E 03	29	1.100000E 05
8	-8.000000E 04	19	1.000000E 04	30	1.200000E 05
9	-7.000000E 04	20	2.000000E 04	31	1.300000E 05
10	-6.000000E 04	21	3.000000E 04	32	1.400000E 05
11	-5.000000E 04	22	4.000000E 04	33	1.500000E 05

Fig. 2-4-29 Model 0-1, FPL Load, View 1, Airfoil Suction Side Maximum Principal Shear (psi)

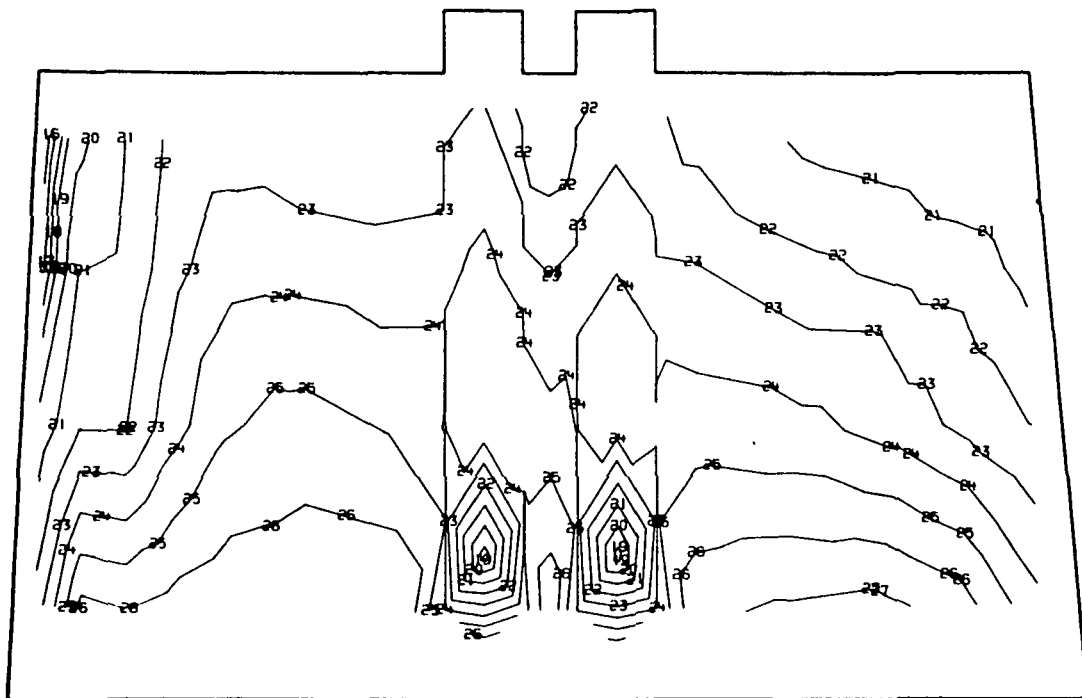

1	-1.500000E 05	05	12	-4.000000E 04	04	23	5.000000E 04	04
2	-1.400000E 05	05	13	-3.000000E 04	04	24	6.000000E 04	04
3	-1.300000E 05	05	14	-2.000000E 04	04	25	7.000000E 04	04
4	-1.200000E 05	05	15	-1.000000E 04	04	26	8.000000E 04	04
5	-1.100000E 05	05	16	-5.000000E 03	03	27	9.000000E 04	04
6	-1.000000E 05	05	17	0.0		28	1.000000E 05	05
7	-9.000000E 04	04	18	5.000000E 03	03	29	1.100000E 05	05
8	-8.000000E 04	04	19	1.000000E 04	04	30	1.200000E 05	05
9	-7.000000E 04	04	20	2.000000E 04	04	31	1.300000E 05	05
10	-6.000000E 04	04	21	3.000000E 04	04	32	1.400000E 05	05
11	-5.000000E 04	04	22	4.000000E 04	04	33	1.500000E 05	05

Fig. 2.4-30 Model 0-1, 115% Load, View 2, Shank Pressure Side Major Principal Stress (psi)

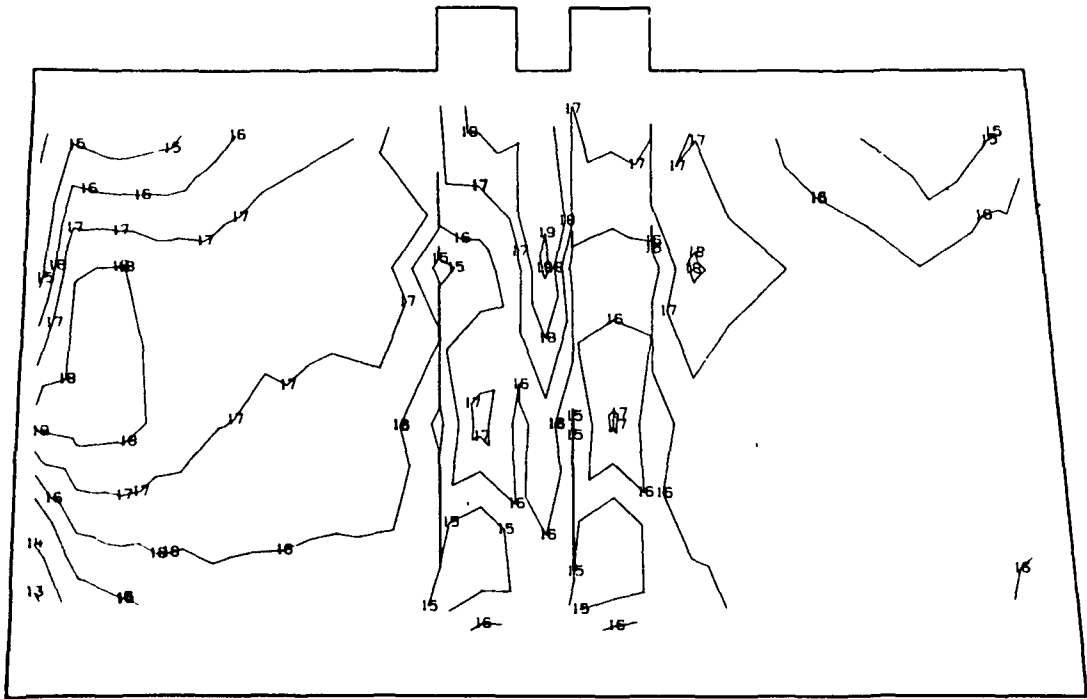

1	-1.500000E 05	12	-4.000000E 04	23	5.000000E 04
2	-1.400000E 05	13	-3.000000E 04	24	6.000000E 04
3	-1.300000E 05	14	-2.000000E 04	25	7.000000E 04
4	-1.200000E 05	15	-1.000000E 04	26	8.000000E 04
5	-1.100000E 05	16	-5.000000E 03	27	9.000000E 04
6	-1.000000E 05	17	0.0	28	1.000000E 05
7	-9.000000E 04	18	5.000000E 03	29	1.100000E 05
8	-8.000000E 04	19	1.000000E 04	30	1.200000E 05
9	-7.000000E 04	20	2.000000E 04	31	1.300000E 05
10	-6.000000E 04	21	3.000000E 04	32	1.400000E 05
11	-5.000000E 04	22	4.000000E 04	33	1.500000E 05

Fig. 2.4-31 Model 0-1, 115% Load, View 2, Shank Pressure Side Minor Principal Stress (psi)

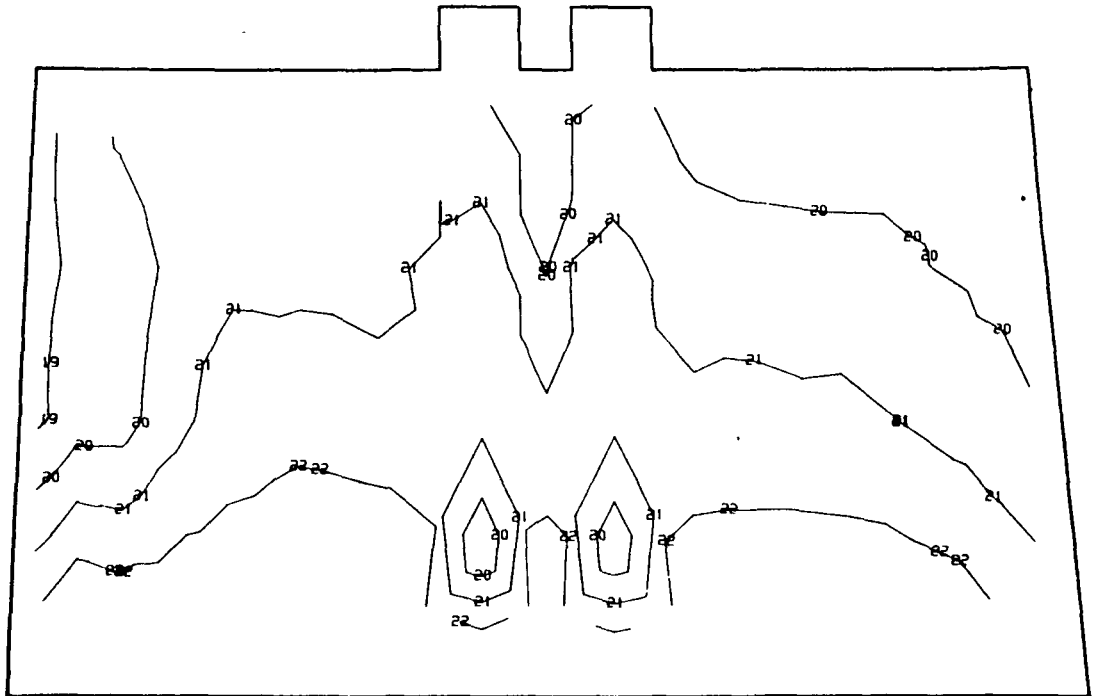

1	-1.500000E 05	12	-4.000000E 04	23	5.000000E 04
2	-1.400000E 05	13	-3.000000E 04	24	6.000000E 04
3	-1.300000E 05	14	-2.000000E 04	25	7.000000E 04
4	-1.200000E 05	15	-1.000000E 04	26	8.000000E 04
5	-1.100000E 05	16	-5.000000E 03	27	9.000000E 04
6	-1.000000E 05	17	0.0	28	1.000000E 05
7	-9.000000E 04	18	5.000000E 03	29	1.100000E 05
8	-8.000000E 04	19	1.000000E 04	30	1.200000E 05
9	-7.000000E 04	20	2.000000E 04	31	1.300000E 05
10	-6.000000E 04	21	3.000000E 04	32	1.400000E 05
11	-5.000000E 04	22	4.000000E 04	33	1.500000E 05

Fig. 2.4-32 Model 0-1, FPL Load, View 2, Shank Pressure Side Maximum Principal Shear (psi)

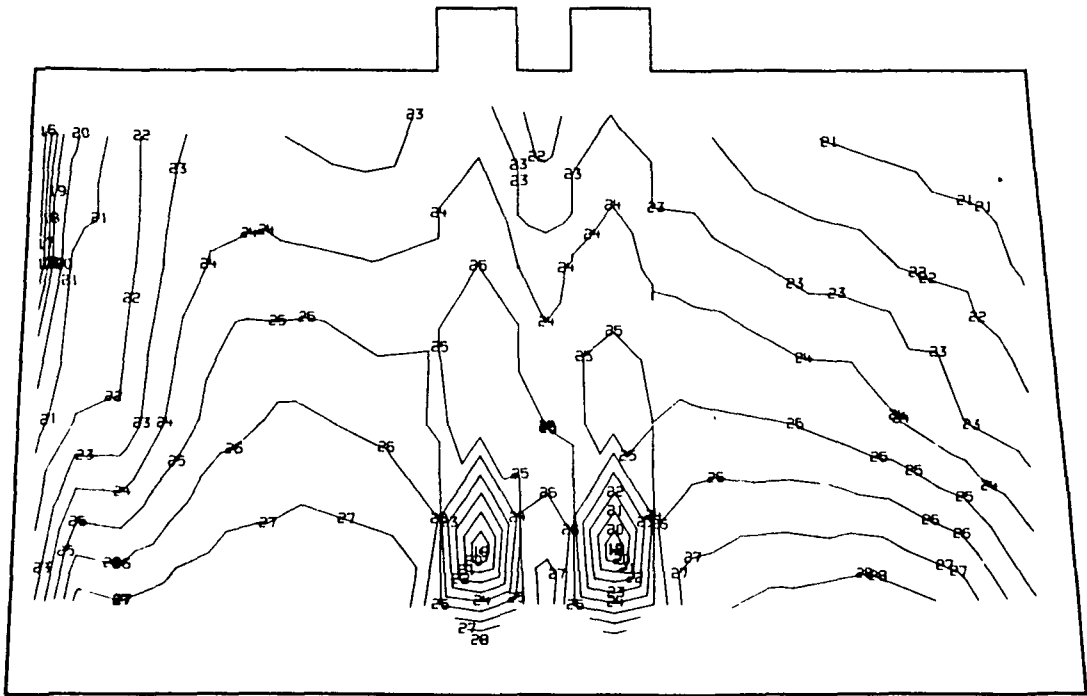

1	-1.500000E 05	12	-4.000000E 04	23	5.000000E 04
2	-1.400000E 05	13	-3.000000E 04	24	6.000000E 04
3	-1.300000E 05	14	-2.000000E 04	25	7.000000E 04
4	-1.200000E 05	15	-1.000000E 04	26	8.000000E 04
5	-1.100000E 05	16	-5.000000E 03	27	9.000000E 04
6	-1.000000E 05	17	0.0	28	1.000000E 05
7	-9.000000E 04	18	5.000000E 03	29	1.100000E 05
8	-8.000000E 04	19	1.000000E 04	30	1.200000E 05
9	-7.000000E 04	20	2.000000E 04	31	1.300000E 05
10	-6.000000E 04	21	3.000000E 04	32	1.400000E 05
11	-5.000000E 04	22	4.000000E 04	33	1.500000E 05

Fig. 2.4-33 Model 0-1, 115% Load, View 2, Shank Pressure Side Major Principal Stress (psi)

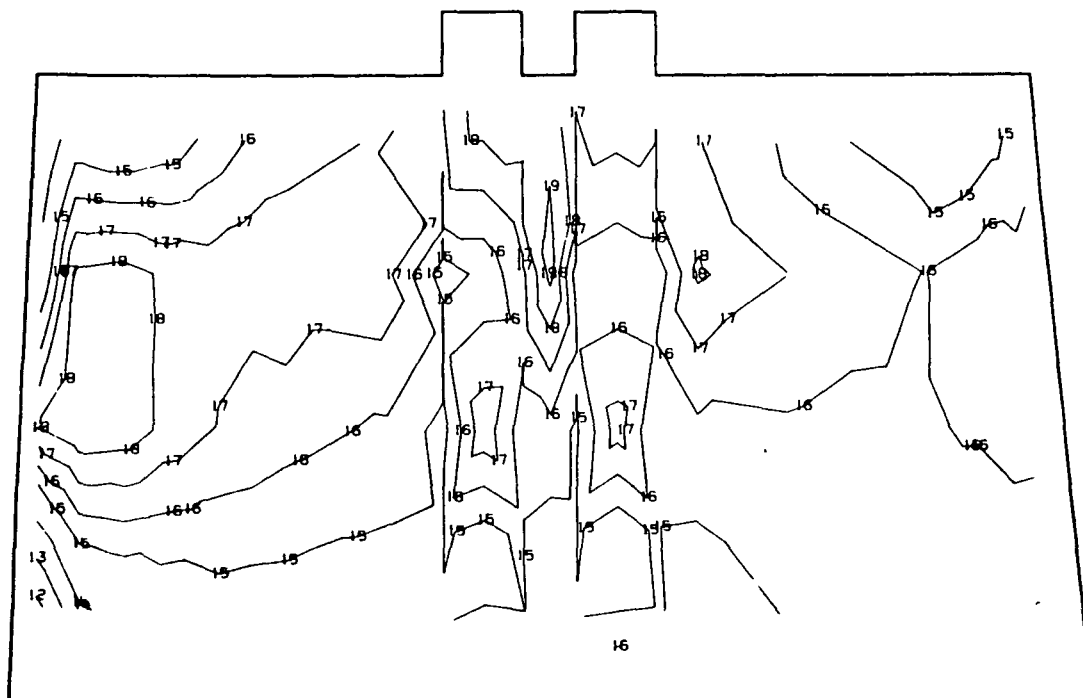

1	-1.500000E 05	12	-4.000000E 04	23	5.000000E 04
2	-1.400000E 05	13	-3.000000E 04	24	6.000000E 04
3	-1.300000E 05	14	-2.000000E 04	25	7.000000E 04
4	-1.200000E 05	15	-1.000000E 04	26	8.000000E 04
5	-1.100000E 05	16	-5.000000E 03	27	9.000000E 04
6	-1.000000E 05	17	0.0	28	1.000000E 05
7	-9.000000E 04	18	5.000000E 03	29	1.100000E 05
8	-8.000000E 04	19	1.000000E 04	30	1.200000E 05
9	-7.000000E 04	20	2.000000E 04	31	1.300000E 05
10	-6.000000E 04	21	3.000000E 04	32	1.400000E 05
11	-5.000000E 04	22	4.000000E 04	33	1.500000E 05

Fig. 2.4-34 Model 0-1, 115% Load, View 2, Shank Pressure Side Minor Principal Stress (psi)

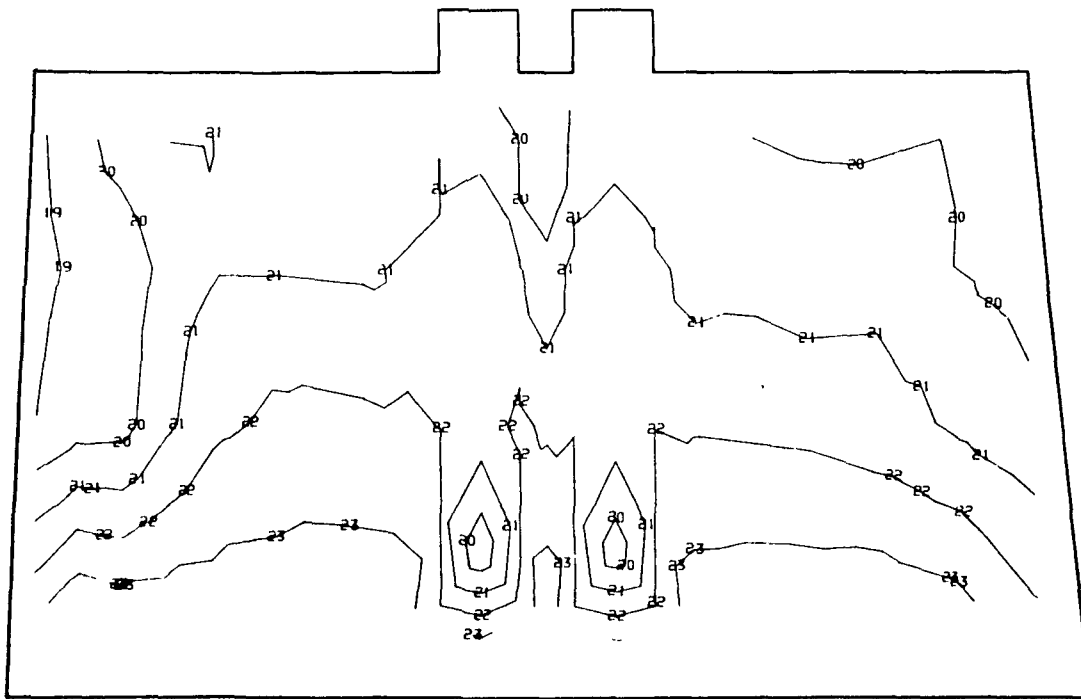

1	-1.500000E 05	12	-4.000000E 04	23	5.000000E 04
2	-1.400000E 05	13	-3.000000E 04	24	6.000000E 04
3	-1.300000E 05	14	-2.000000E 04	25	7.000000E 04
4	-1.200000E 05	15	-1.000000E 04	26	8.000000E 04
5	-1.100000E 05	16	-5.000000E 03	27	9.000000E 04
6	-1.000000E 05	17	0.0	28	1.000000E 05
7	-9.000000E 04	18	5.000000E 03	29	1.100000E 05
8	-8.000000E 04	19	1.000000E 04	30	1.200000E 05
9	-7.000000E 04	20	2.000000E 04	31	1.300000E 05
10	-6.000000E 04	21	3.000000E 04	32	1.400000E 05
11	-5.000000E 04	22	4.000000E 04	33	1.500000E 05

Fig. 2.4-35 Model 0-1, FPL Load, View 2, Shank Pressure Side Maximum Principal Shear (psi)

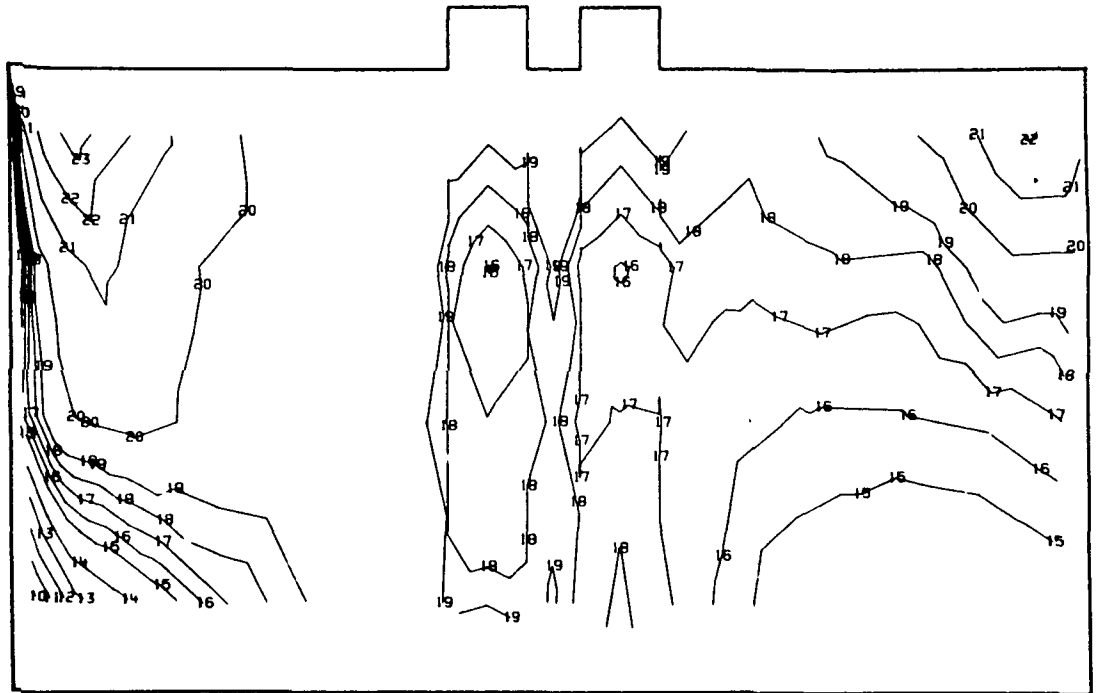

1	-1.500000E 05	12	-4.000000E 04	23	5.000000E 04
2	-1.400000E 05	13	-3.000000E 04	24	6.000000E 04
3	-1.300000E 05	14	-2.000000E 04	25	7.000000E 04
4	-1.200000E 05	15	-1.000000E 04	26	8.000000E 04
5	-1.100000E 05	16	-5.000000E 03	27	9.000000E 04
6	-1.000000E 05	17	0.0	28	1.000000E 05
7	-9.000000E 04	18	5.000000E 03	29	1.100000E 05
8	-8.000000E 04	19	1.000000E 04	30	1.200000E 05
9	-7.000000E 04	20	2.000000E 04	31	1.300000E 05
10	-6.000000E 04	21	3.000000E 04	32	1.400000E 05
11	-5.000000E 04	22	4.000000E 04	33	1.500000E 05

Fig. 2.4-36 Model 0-1, 115% Load, View 2, Shank Suction Side Major Principal Stress (psi)

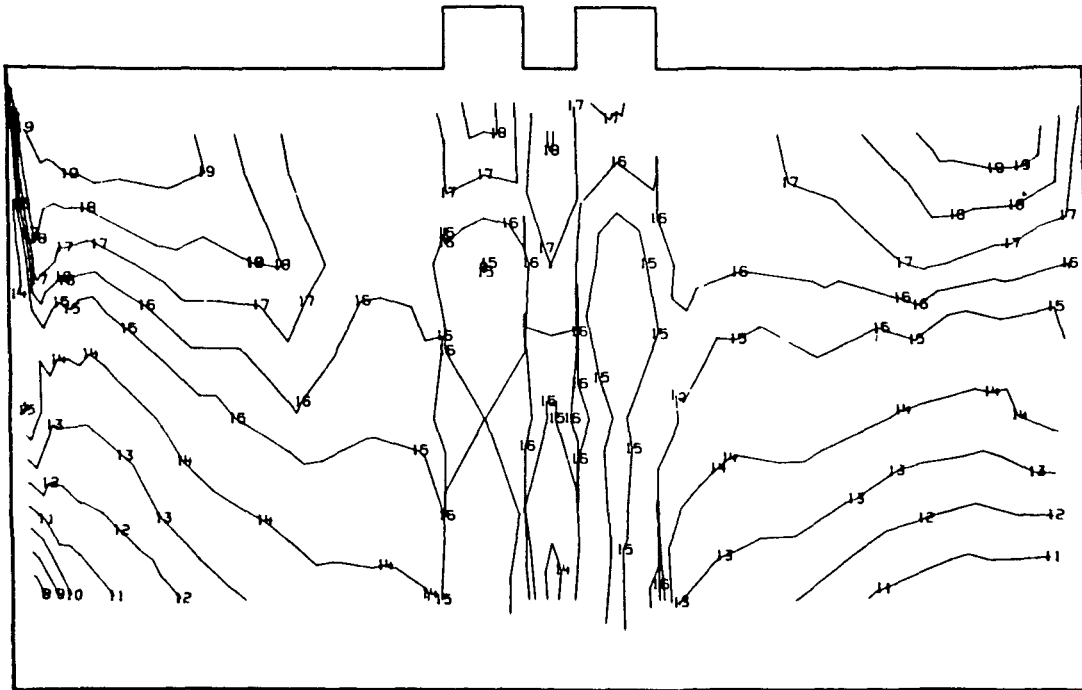

1	-1.500000E 05	12	-4.000000E 04	23	5.000000E 04
2	-1.400000E 05	13	-3.000000E 04	24	6.000000E 04
3	-1.300000E 05	14	-2.000000E 04	25	7.000000E 04
4	-1.200000E 05	15	-1.000000E 04	26	8.000000E 04
5	-1.100000E 05	16	-5.000000E 03	27	9.000000E 04
6	-1.000000E 05	17	0.0	28	1.000000E 05
7	-9.000000E 04	18	5.000000E 03	29	1.100000E 05
8	-8.000000E 04	19	1.000000E 04	30	1.200000E 05
9	-7.000000E 04	20	2.000000E 04	31	1.300000E 05
10	-6.000000E 04	21	3.000000E 04	32	1.400000E 05
11	-5.000000E 04	22	4.000000E 04	33	1.500000E 05

Fig. 2.4-37 Model 0-1, FLP Load, View 2, Shank Suction Side Minor Principal Stress (psi)

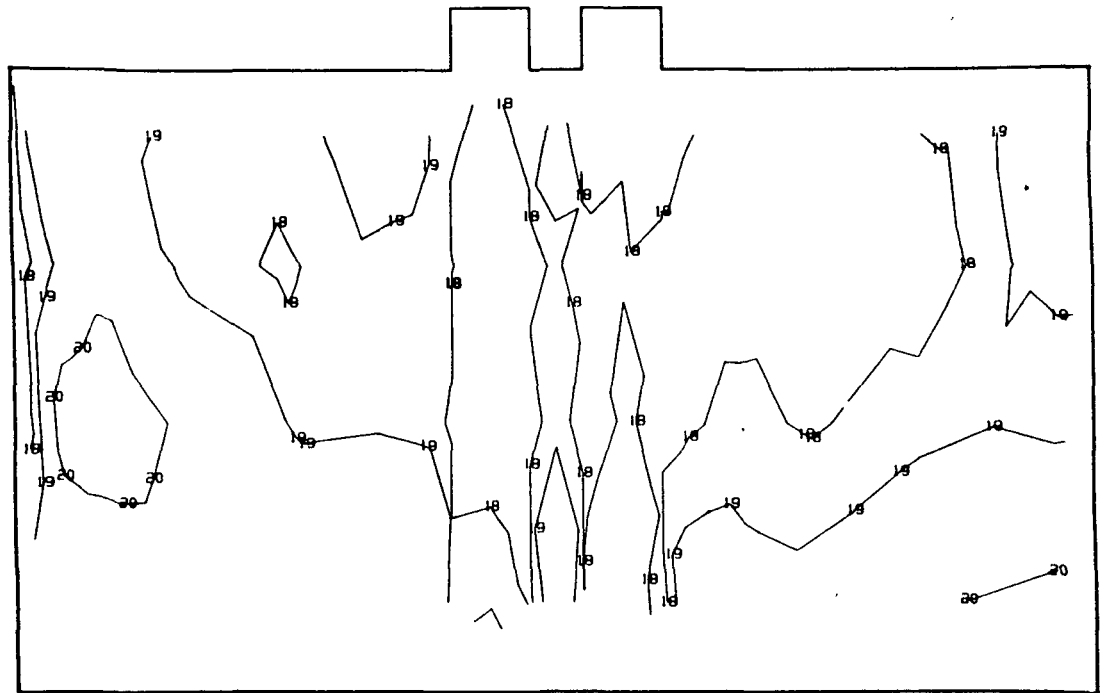

1	-1.500000E	05	12	-4.000000E	04	23	5.000000E	04
2	-1.400000E	05	13	-3.000000E	04	24	6.000000E	04
3	-1.300000E	05	14	-2.000000E	04	25	7.000000E	04
4	-1.200000E	05	15	-1.000000E	04	26	8.000000E	04
5	-1.100000E	05	16	-5.000000E	03	27	9.000000E	04
6	-1.000000E	05	17	0.0		28	1.000000E	05
7	-9.000000E	04	18	5.000000E	03	29	1.100000E	05
8	-8.000000E	04	19	1.000000E	04	30	1.200000E	05
9	-7.000000E	04	20	2.000000E	04	31	1.300000E	05
10	-6.000000E	04	21	3.000000E	04	32	1.400000E	05
11	-5.000000E	04	22	4.000000E	04	33	1.500000E	05

Fig. 2.4-38 Model 0-1, FPL Load, View 2, Shank Suction Side Maximum Principal Shear (psi)

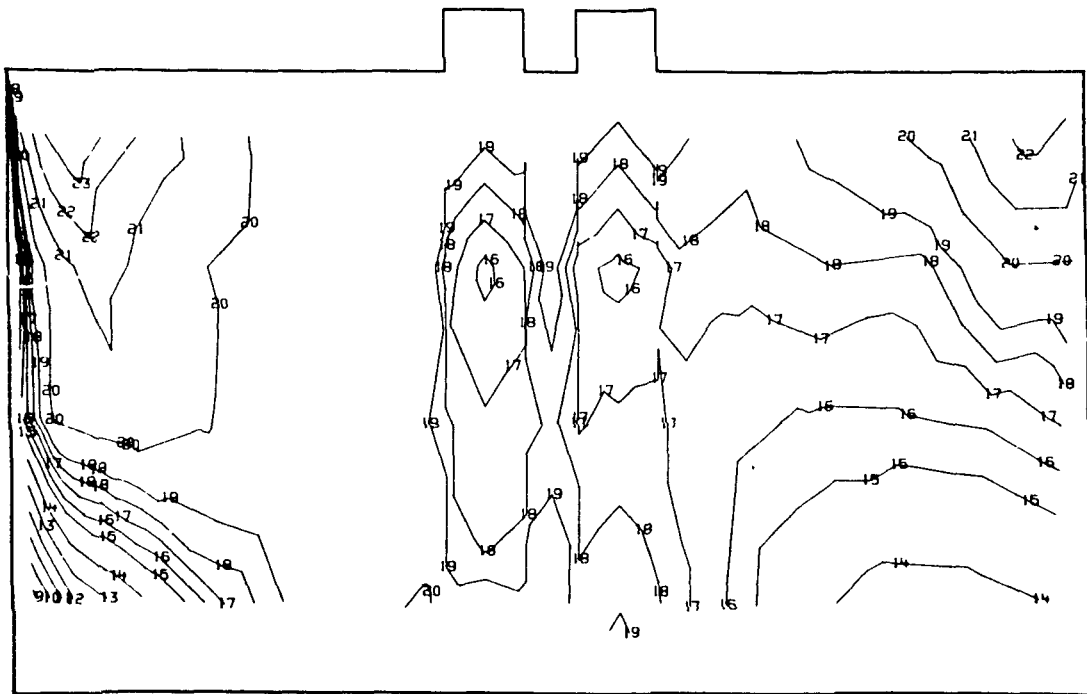

1	-1.500000E 05	12	-4.000000E 04	23	5.000000E 04
2	-1.400000E 05	13	-3.000000E 04	24	6.000000E 04
3	-1.300000E 05	14	-2.000000E 04	25	7.000000E 04
4	-1.200000E 05	15	-1.000000E 04	26	8.000000E 04
5	-1.100000E 05	16	-5.000000E 03	27	9.000000E 04
6	-1.000000E 05	17	0.0	28	1.000000E 05
7	-9.000000E 04	18	5.000000E 03	29	1.100000E 05
8	-8.000000E 04	19	1.000000E 04	30	1.200000E 05
9	-7.000000E 04	20	2.000000E 04	31	1.300000E 05
10	-6.000000E 04	21	3.000000E 04	32	1.400000E 05
11	-5.000000E 04	22	4.000000E 04	33	1.500000E 05

Fig. 2.4-39 Model 0-1, 115% Load, View 2, Shank Suction Side Major Principal Stress (psi)

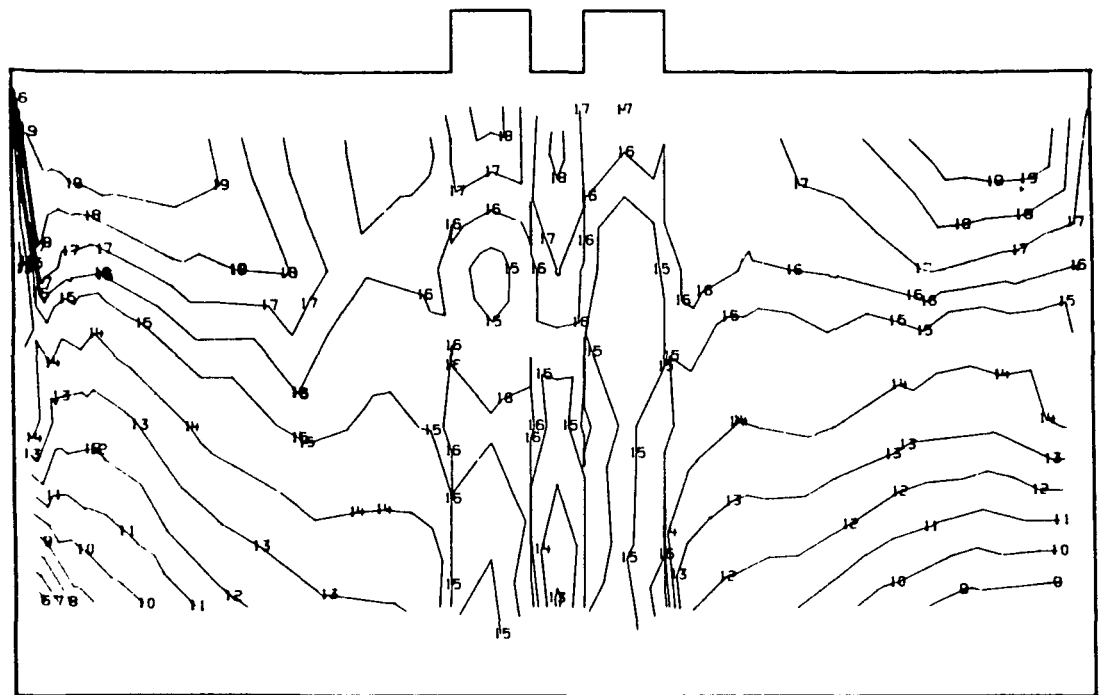

1	-1.500000E 05	12	-4.000000E 04	23	5.000000E 04
2	-1.400000E 05	13	-3.000000E 04	24	6.000000E 04
3	-1.300000E 05	14	-2.000000E 04	25	7.000000E 04
4	-1.200000E 05	15	-1.000000E 04	26	8.000000E 04
5	-1.100000E 05	16	-5.000000E 03	27	9.000000E 04
6	-1.000000E 05	17	0.0	28	1.000000E 05
7	-9.000000E 04	18	5.000000E 03	29	1.100000E 05
8	-8.000000E 04	19	1.000000E 04	30	1.200000E 05
9	-7.000000E 04	20	2.000000E 04	31	1.300000E 05
10	-6.000000E 04	21	3.000000E 04	32	1.400000E 05
11	-5.000000E 04	22	4.000000E 04	33	1.500000E 05

Fig. 2.4-40 Model 0-1, 115% Load, View 2, Shank Suction Side Minor Principal Stress (psi)

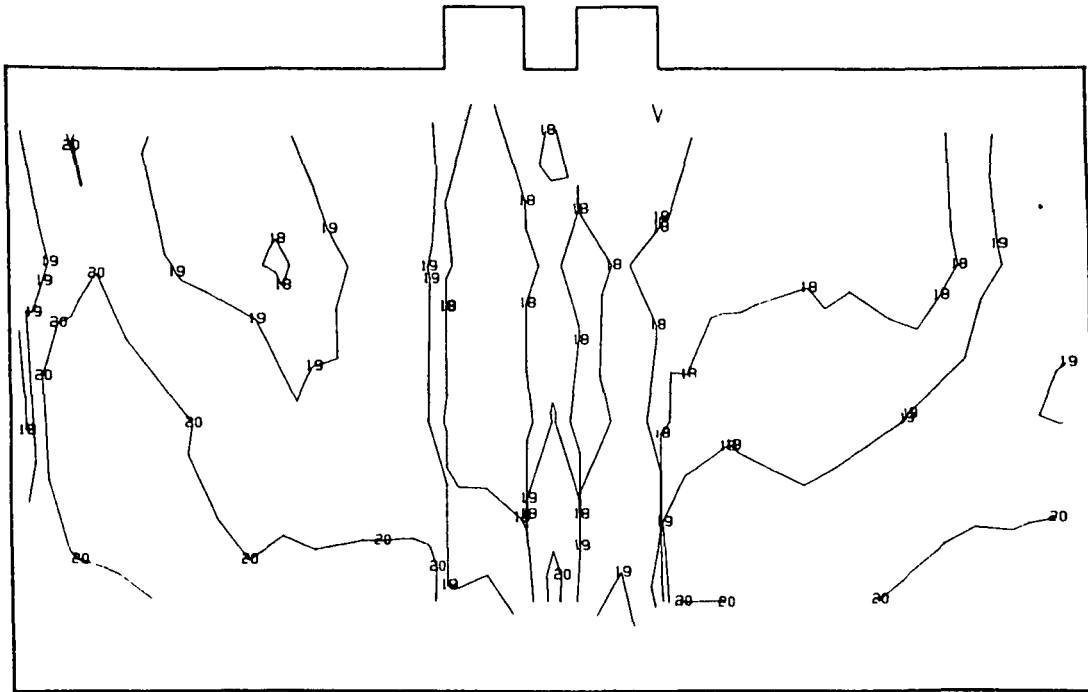

1	-1.500000E 05	12	-4.000000E 04	23	5.000000E 04
2	-1.400000E 05	13	-3.000000E 04	24	6.000000E 04
3	-1.300000E 05	14	-2.000000E 04	25	7.000000E 04
4	-1.200000E 05	15	-1.000000E 04	26	8.000000E 04
5	-1.100000E 05	16	-5.000000E 03	27	9.000000E 04
6	-1.000000E 05	17	0.0	28	1.000000E 05
7	-9.000000E 04	18	5.000000E 03	29	1.100000E 05
8	-8.000000E 04	19	1.000000E 04	30	1.200000E 05
9	-7.000000E 04	20	2.000000E 04	31	1.300000E 05
10	-6.000000E 04	21	3.000000E 04	32	1.400000E 05
11	-5.000000E 04	22	4.000000E 04	33	1.500000E 05

Fig. 2.4-41 Model 0-1, 115% Load, View 2, Shank Suction Side Maximum Principal Shear (psi)

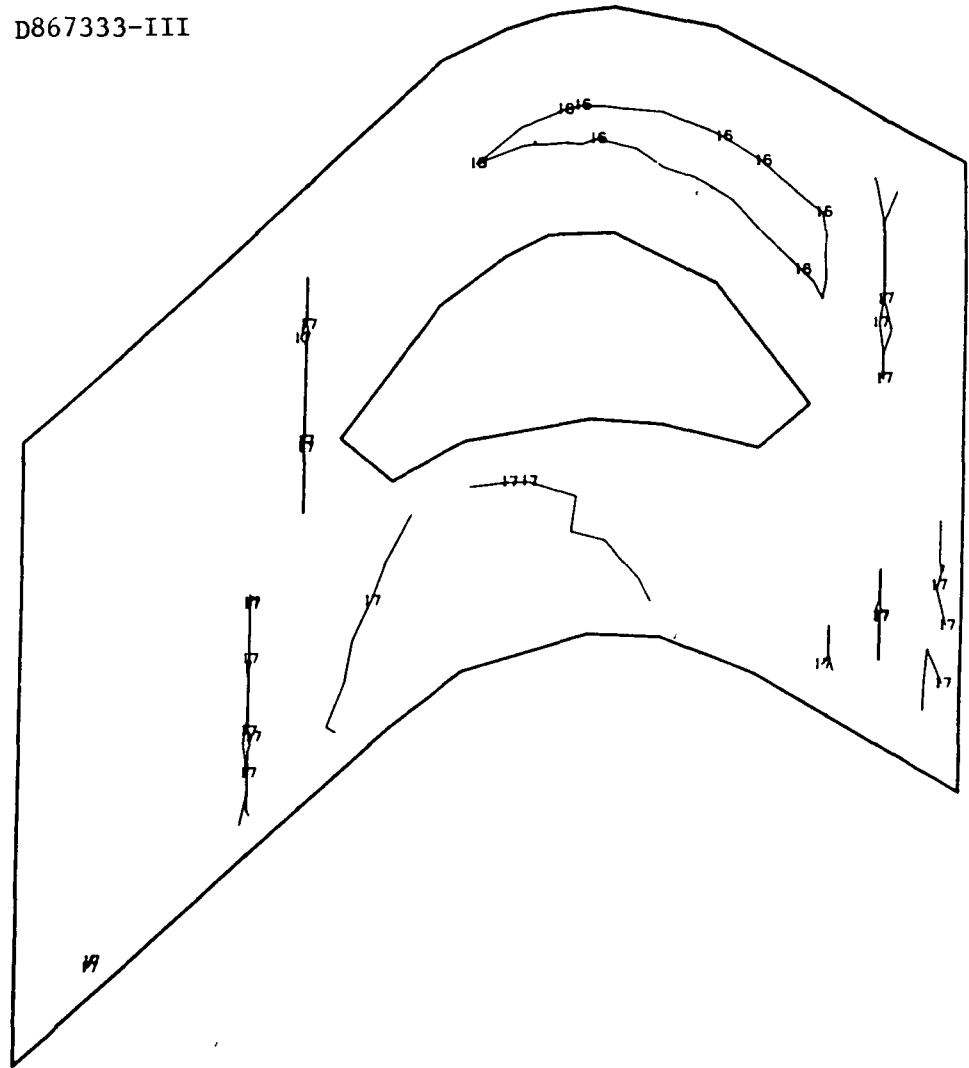

1	-1.500000E 05	12	-4.000000E 04	23	5.000000E 04
2	-1.400000E 05	13	-3.000000E 04	24	6.000000E 04
3	-1.300000E 05	14	-2.000000E 04	25	7.000000E 04
4	-1.200000E 05	15	-1.000000E 04	26	8.000000E 04
5	-1.100000E 05	16	-5.000000E 03	27	9.000000E 04
6	-1.000000E 05	17	0.0	28	1.000000E 05
7	-9.000000E 04	18	5.000000E 03	29	1.100000E 05
8	-8.000000E 04	19	1.000000E 04	30	1.200000E 05
9	-7.000000E 04	20	2.000000E 04	31	1.300000E 05
10	-6.000000E 04	21	3.000000E 04	32	1.400000E 05
11	-5.000000E 04	22	4.000000E 04	33	1.500000E 05

Fig. 2.4-42 Model 0-1, FPL Load, View 3, Shroud Top Major Principal Shear (psi)

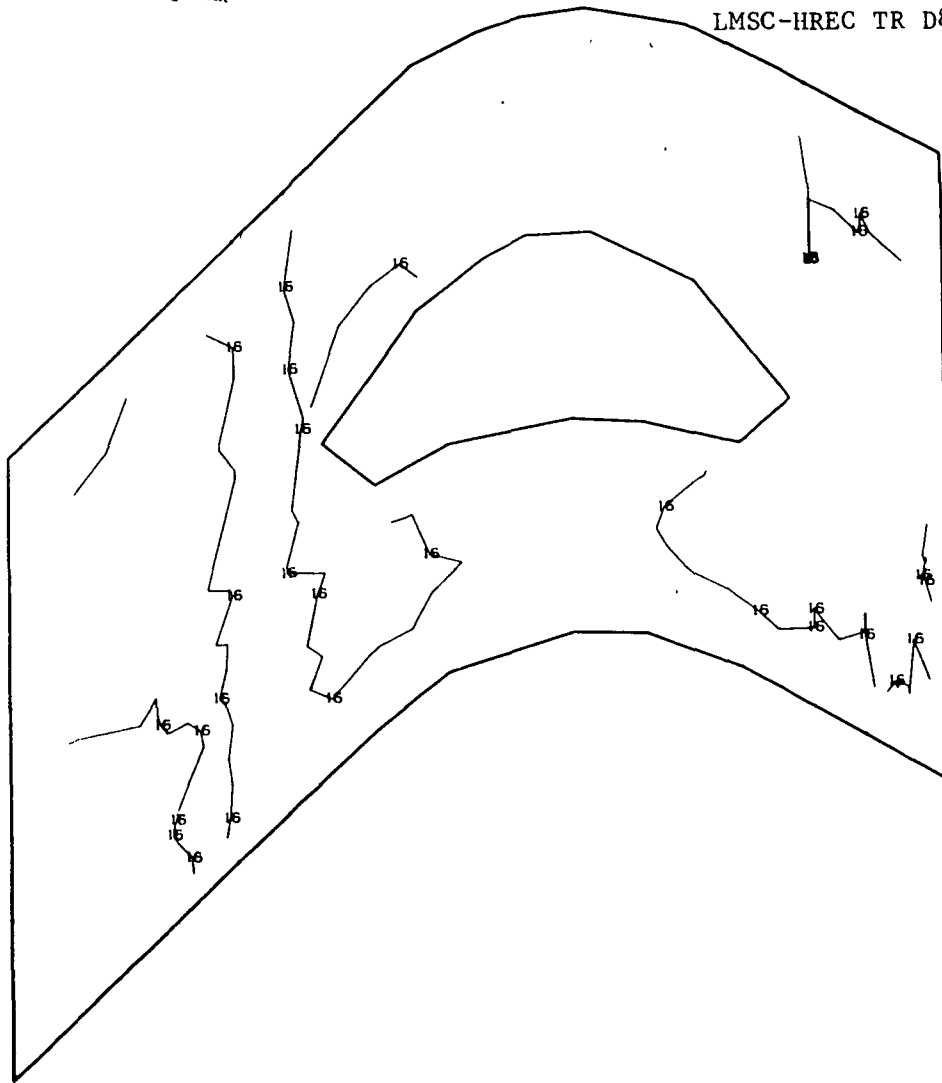

1	-1.500000E 05	12	-4.000000E 04	23	5.000000E 04
2	-1.400000E 05	13	-3.000000E 04	24	6.000000E 04
3	-1.300000E 05	14	-2.000000E 04	25	7.000000E 04
4	-1.200000E 05	15	-1.000000E 04	26	8.000000E 04
5	-1.100000E 05	16	-5.000000E 03	27	9.000000E 04
6	-1.000000E 05	17	0.0	28	1.000000E 05
7	-9.000000E 04	18	5.000000E 03	29	1.100000E 05
8	-8.000000E 04	19	1.000000E 04	30	1.200000E 05
9	-7.000000E 04	20	2.000000E 04	31	1.300000E 05
10	-6.000000E 04	21	3.000000E 04	32	1.400000E 05
11	-5.000000E 04	22	4.000000E 04	33	1.500000E 05

Fig. 2.4-43 Model 0-1, FPL Load, View 3, Shroud Top Minor Principal Stress (psi)

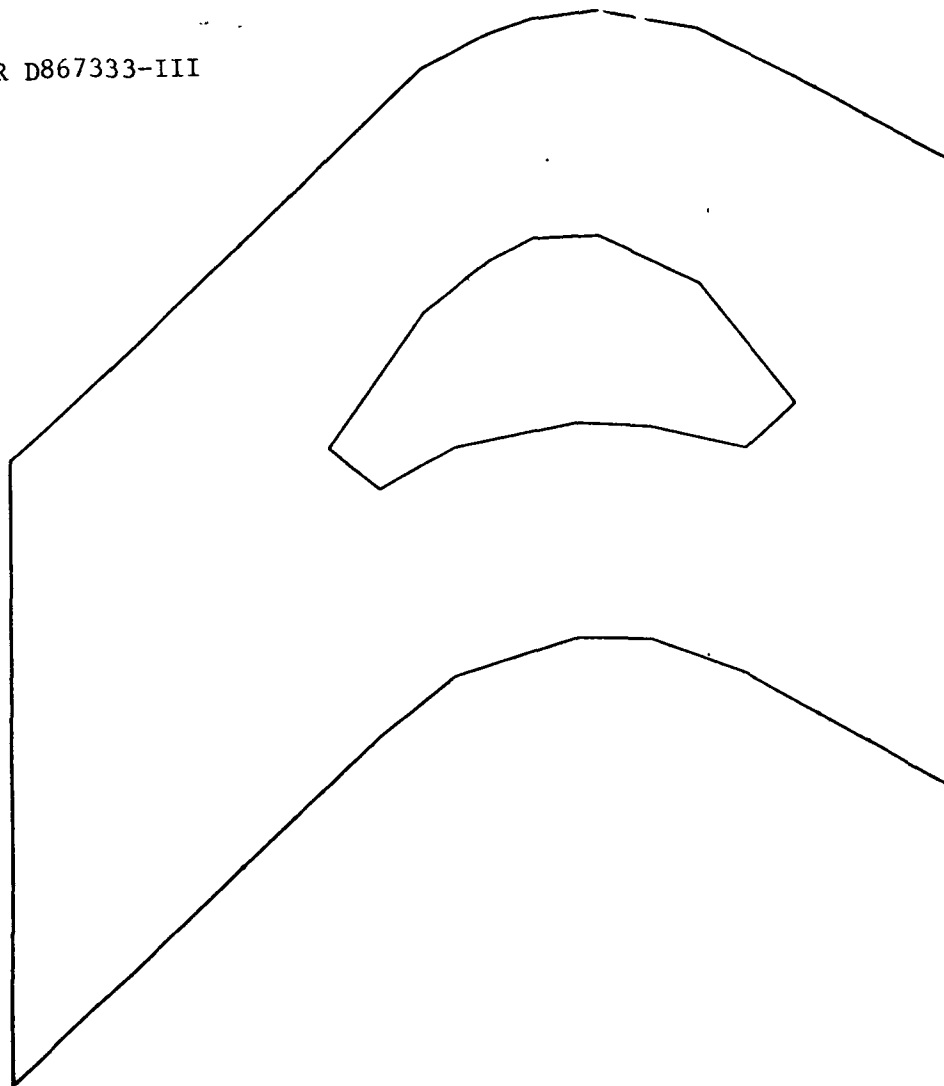

1	-1.500000E 05	12	-4.000000E 04	23	5.000000E 04
2	-1.400000E 05	13	-3.000000E 04	24	6.000000E 04
3	-1.300000E 05	14	-2.000000E 04	25	7.000000E 04
4	-1.200000E 05	15	-1.000000E 04	26	8.000000E 04
5	-1.100000E 05	16	-5.000000E 03	27	9.000000E 04
6	-1.000000E 05	17	0.0	28	1.000000E 05
7	-9.000000E 04	18	5.000000E 03	29	1.100000E 05
8	-8.000000E 04	19	1.000000E 04	30	1.200000E 05
9	-7.000000E 04	20	2.000000E 04	31	1.300000E 05
10	-6.000000E 04	21	3.000000E 04	32	1.400000E 05
11	-5.000000E 04	22	4.000000E 04	33	1.500000E 05

Fig. 2.4-44 Model 0-1, FPL Load, View 3, Shroud Top Maximum Principal Stress (psi)

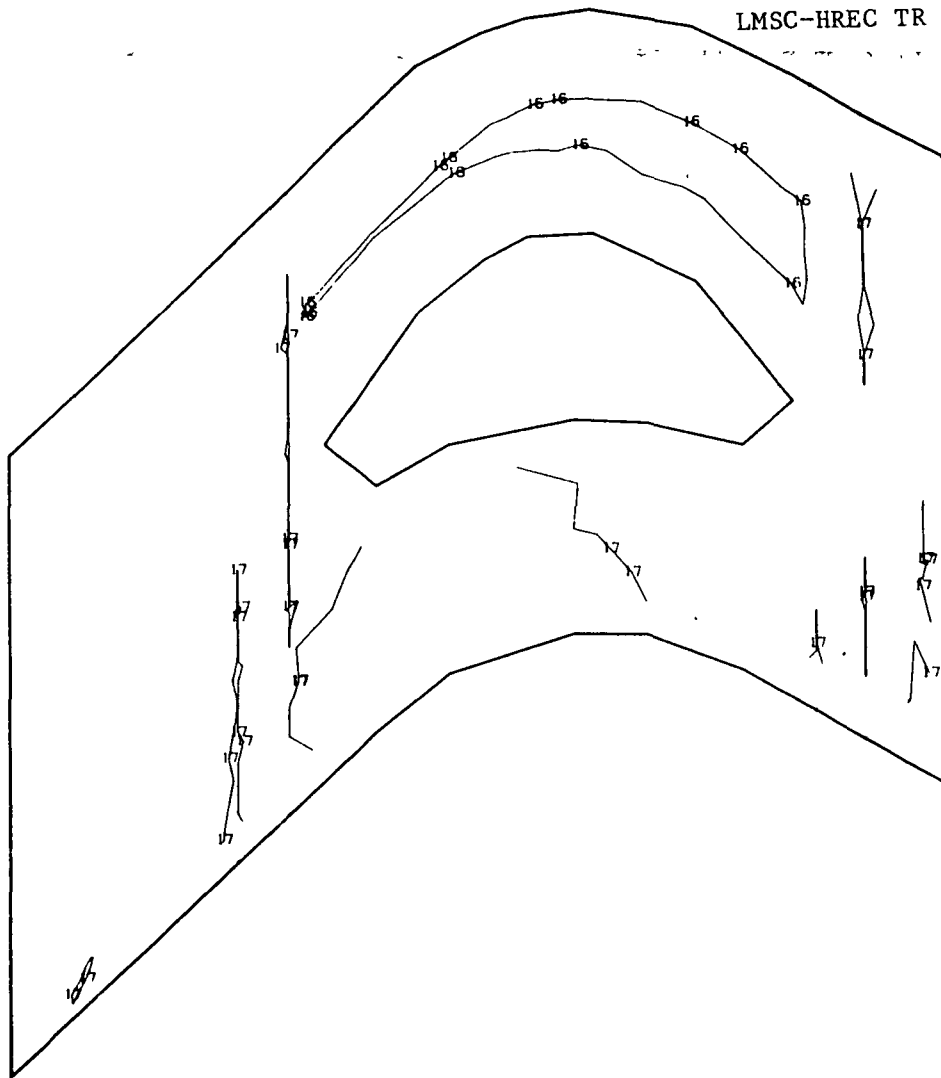

1	-1.500000E 05	12	-4.000000E 04	23	5.000000E 04
2	-1.400000E 05	13	-3.000000E 04	24	6.000000E 04
3	-1.300000E 05	14	-2.000000E 04	25	7.000000E 04
4	-1.200000E 05	15	-1.000000E 04	26	8.000000E 04
5	-1.100000E 05	16	-5.000000E 03	27	9.000000E 04
6	-1.000000E 05	17	0.0	28	1.000000E 05
7	-9.000000E 04	18	5.000000E 03	29	1.100000E 05
8	-8.000000E 04	19	1.000000E 04	30	1.200000E 05
9	-7.000000E 04	20	2.000000E 04	31	1.300000E 05
10	-6.000000E 04	21	3.000000E 04	32	1.400000E 05
11	-5.000000E 04	22	4.000000E 04	33	1.500000E 05

Fig. 2.4-45 Model 0-1, 115% Load, View 3, Shroud Top Major Principal Stress (psi)

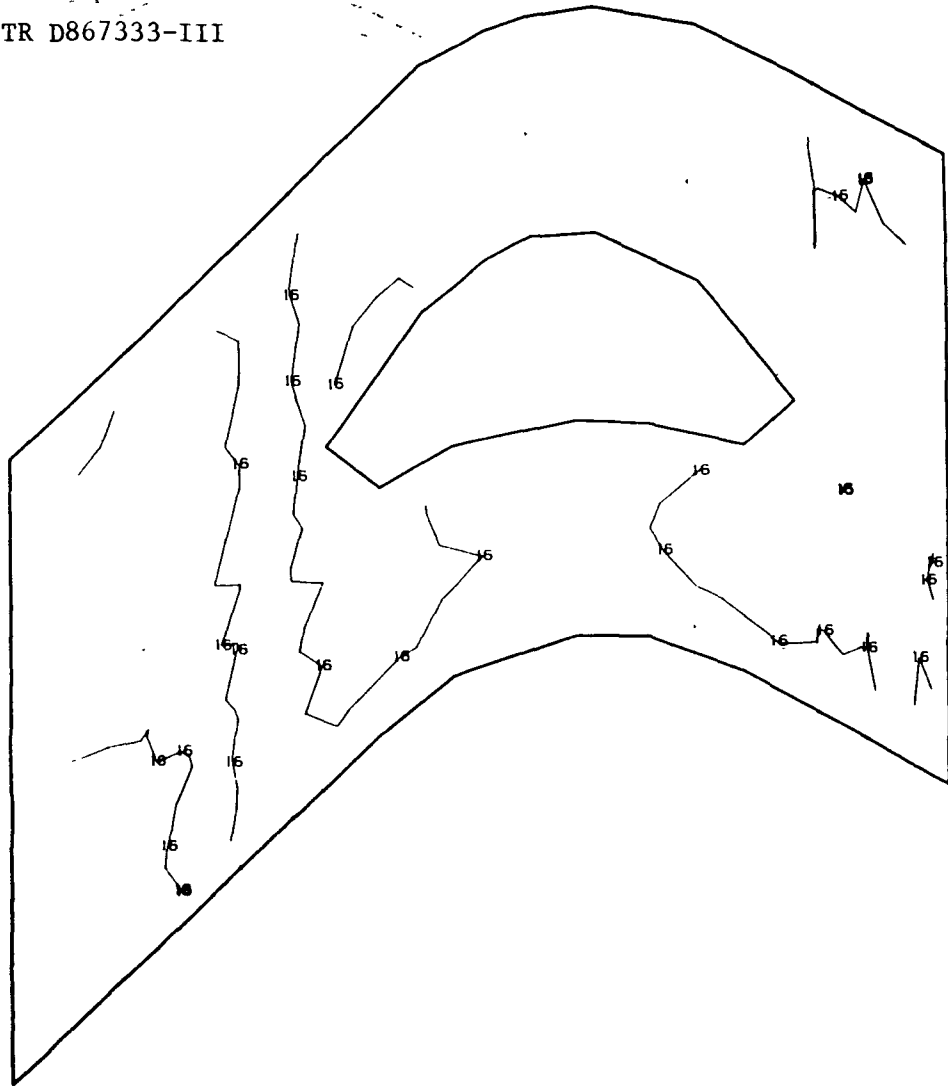

1	-1.500000E 05	12	-4.000000E 04	23	5.000000E 04
2	-1.400000E 05	13	-3.000000E 04	24	6.000000E 04
3	-1.300000E 05	14	-2.000000E 04	25	7.000000E 04
4	-1.200000E 05	15	-1.000000E 04	26	8.000000E 04
5	-1.100000E 05	16	-5.000000E 03	27	9.000000E 04
6	-1.000000E 05	17	0.0	28	1.000000E 05
7	-9.000000E 04	18	5.000000E 03	29	1.100000E 05
8	-8.000000E 04	19	1.000000E 04	30	1.200000E 05
9	-7.000000E 04	20	2.000000E 04	31	1.300000E 05
10	-6.000000E 04	21	3.000000E 04	32	1.400000E 05
11	-5.000000E 04	22	4.000000E 04	33	1.500000E 05

Fig. 2.4-46 Model 0-1, 115% Load, View 3, Shroud Top Minor Principal Stress (psi)

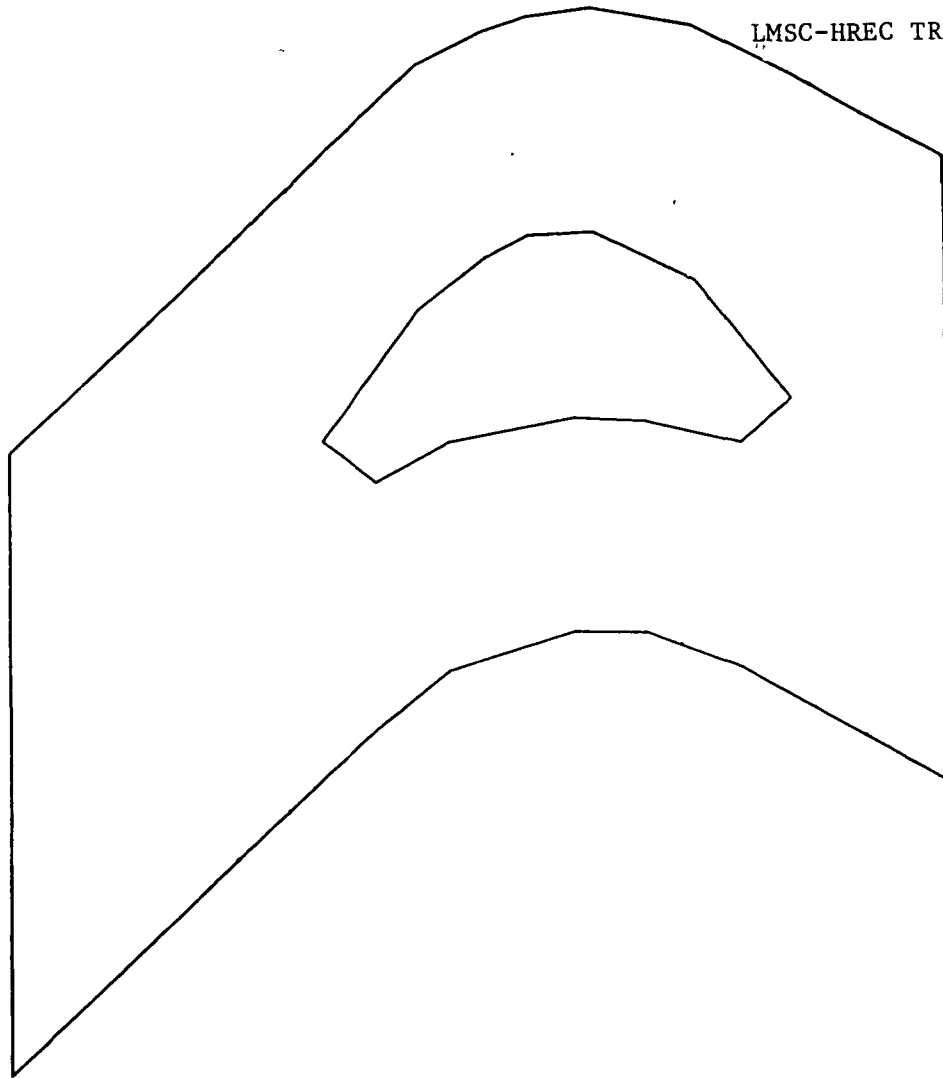

1	-1.500000E 05	12	-4.000000E 04	23	5.000000E 04
2	-1.400000E 05	13	-3.000000E 04	24	6.000000E 04
3	-1.300000E 05	14	-2.000000E 04	25	7.000000E 04
4	-1.200000E 05	15	-1.000000E 04	26	8.000000E 04
5	-1.100000E 05	16	-5.000000E 03	27	9.000000E 04
6	-1.000000E 05	17	0.0	28	1.000000E 05
7	-9.000000E 04	18	5.000000E 03	29	1.100000E 05
8	-8.000000E 04	19	1.000000E 04	30	1.200000E 05
9	-7.000000E 04	20	2.000000E 04	31	1.300000E 05
10	-6.000000E 04	21	3.000000E 04	32	1.400000E 05
11	-5.000000E 04	22	4.000000E 04	33	1.500000E 05

Fig. 2.4-47 Model 0-1, FPL Load, View 3, Shroud Top Maximum Principal Shear (psi)

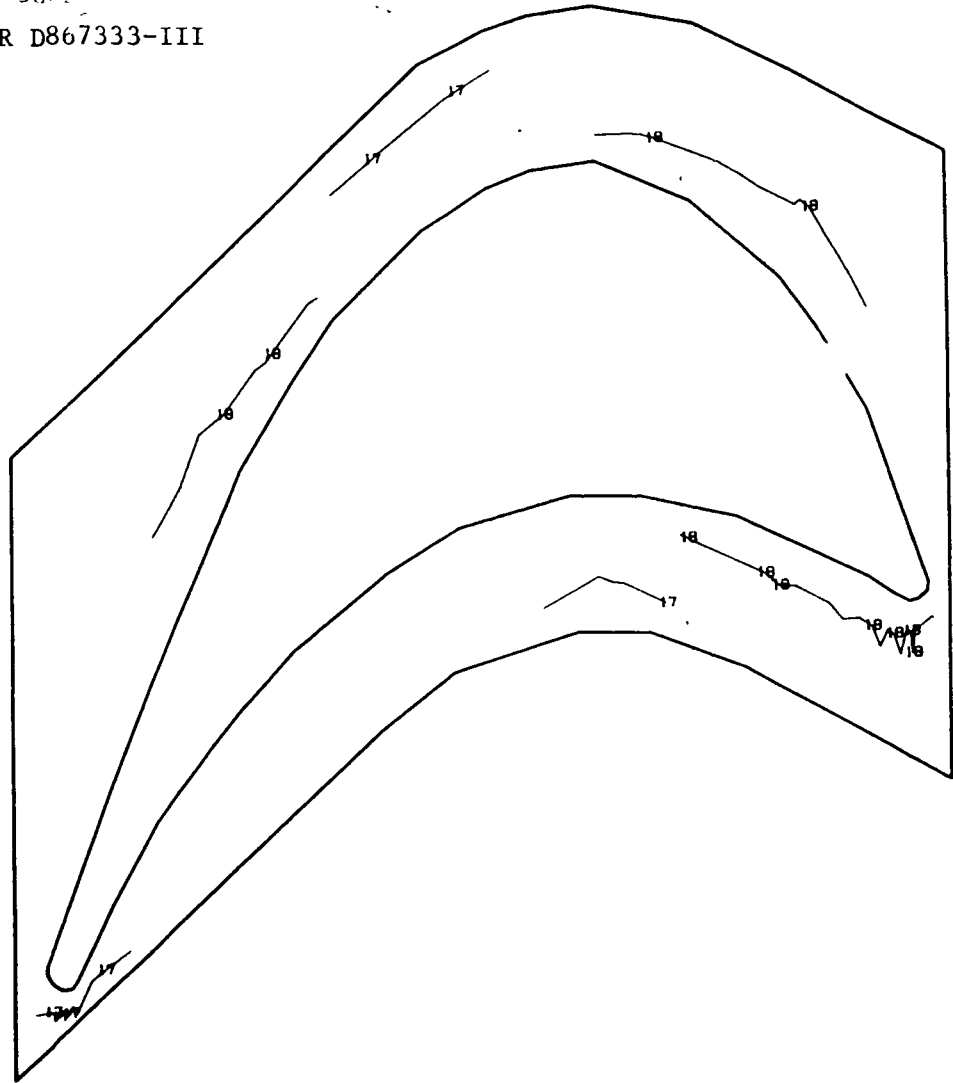

1	-1.500000E 05	12	-4.000000E 04	23	5.000000E 04
2	-1.400000E 05	13	-3.000000E 04	24	6.000000E 04
3	-1.300000E 05	14	-2.000000E 04	25	7.000000E 04
4	-1.200000E 05	15	-1.000000E 04	26	8.000000E 04
5	-1.100000E 05	16	-5.000000E 03	27	9.000000E 04
6	-1.000000E 05	17	0.0	28	1.000000E 05
7	-9.000000E 04	18	5.000000E 03	29	1.100000E 05
8	-8.000000E 04	19	1.000000E 04	30	1.200000E 05
9	-7.000000E 04	20	2.000000E 04	31	1.300000E 05
10	-6.000000E 04	21	3.000000E 04	32	1.400000E 05
11	-5.000000E 04	22	4.000000E 04	33	1.500000E 05

Fig. 2.4-48 Model 0-1, FPL Load, View 3, Shroud Bottom Major Principal Stress (psi)

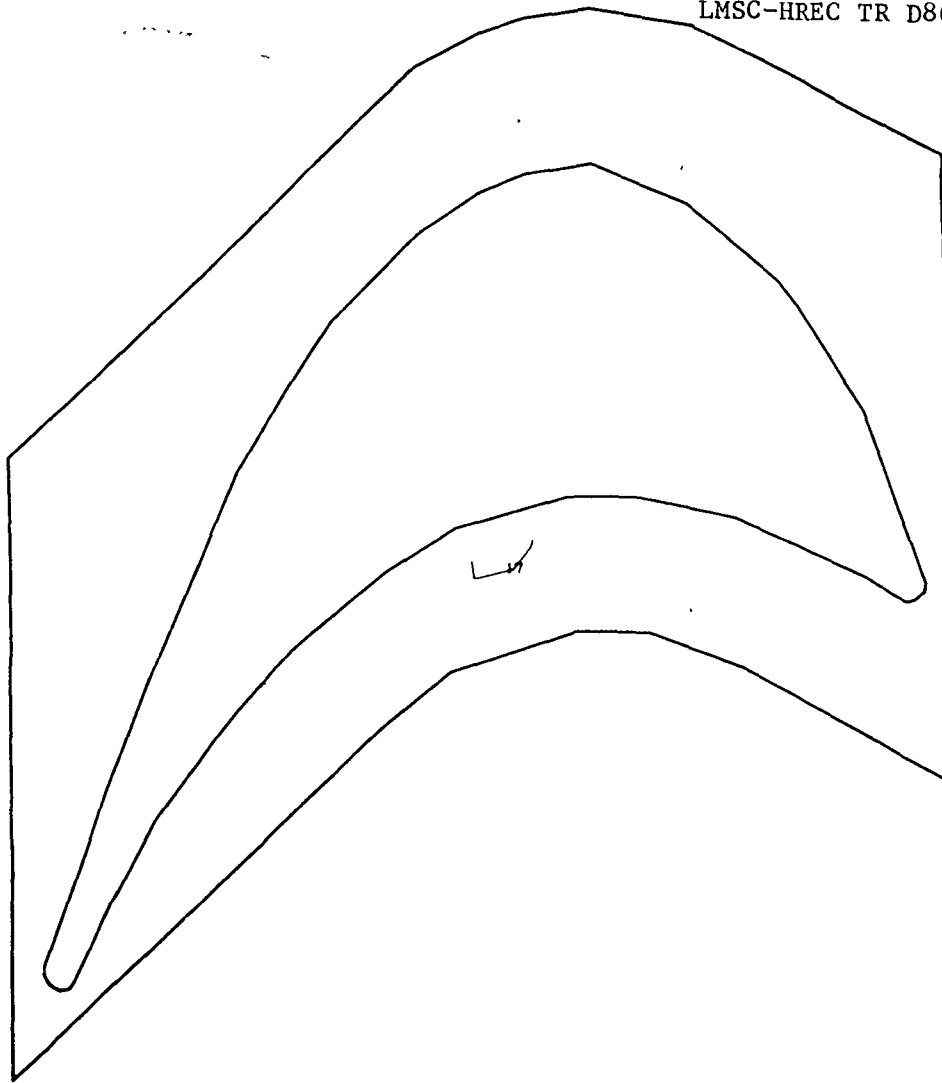

1	-1.500000E 05	12	-4.000000E 04	23	5.000000E 04
2	-1.400000E 05	13	-3.000000E 04	24	6.000000E 04
3	-1.300000E 05	14	-2.000000E 04	25	7.000000E 04
4	-1.200000E 05	15	-1.000000E 04	26	8.000000E 04
5	-1.100000E 05	16	-5.000000E 03	27	9.000000E 04
6	-1.000000E 05	17	0.0	28	1.000000E 05
7	-9.000000E 04	18	5.000000E 03	29	1.100000E 05
8	-8.000000E 04	19	1.000000E 04	30	1.200000E 05
9	-7.000000E 04	20	2.000000E 04	31	1.300000E 05
10	-6.000000E 04	21	3.000000E 04	32	1.400000E 05
11	-5.000000E 04	22	4.000000E 04	33	1.500000E 05

Fig. 2.4-49 Model 0-1, FPL Load, View 3, Shroud Bottom Minor Principal Stress (psi)

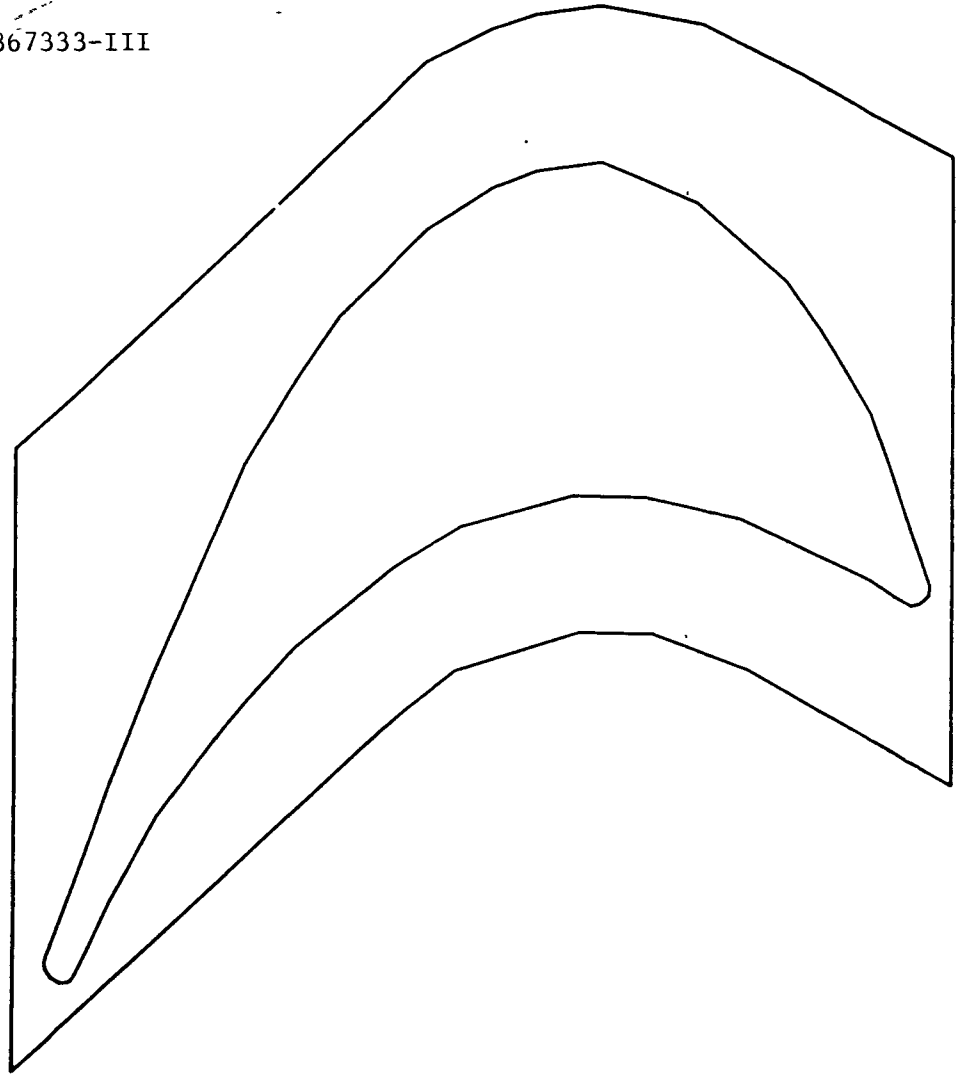

1	-1.500000E 05	12	-4.000000E 04	23	5.000000E 04
2	-1.400000E 05	13	-3.000000E 04	24	6.000000E 04
3	-1.300000E 05	14	-2.000000E 04	25	7.000000E 04
4	-1.200000E 05	15	-1.000000E 04	26	8.000000E 04
5	-1.100000E 05	16	-5.000000E 03	27	9.000000E 04
6	-1.000000E 05	17	0.0	28	1.000000E 05
7	-9.000000E 04	18	5.000000E 03	29	1.100000E 05
8	-8.000000E 04	19	1.000000E 04	30	1.200000E 05
9	-7.000000E 04	20	2.000000E 04	31	1.300000E 05
10	-6.000000E 04	21	3.000000E 04	32	1.400000E 05
11	-5.000000E 04	22	4.000000E 04	33	1.500000E 05

Fig. 2.4-50 Model 0-1, FPL Load, View 3, Shroud Bottom Maximum Principal Stress (psi)

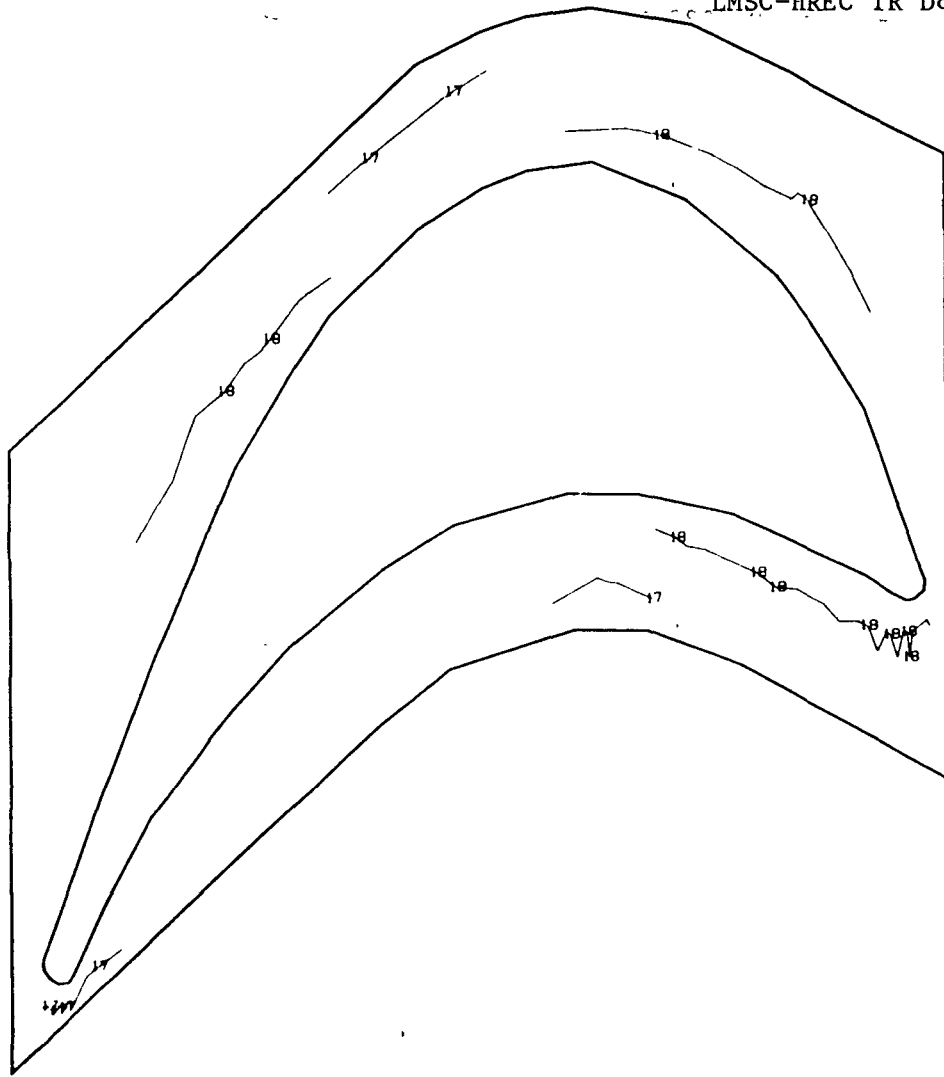

1	-1.500000E 05	12	-4.000000E 04	23	5.000000E 04
2	-1.400000E 05	13	-3.000000E 04	24	6.000000E 04
3	-1.300000E 05	14	-2.000000E 04	25	7.000000E 04
4	-1.200000E 05	15	-1.000000E 04	26	8.000000E 04
5	-1.100000E 05	16	-5.000000E 03	27	9.000000E 04
6	-1.000000E 05	17	0.0	28	1.000000E 05
7	-9.000000E 04	18	5.000000E 03	29	1.100000E 05
8	-8.000000E 04	19	1.000000E 04	30	1.200000E 05
9	-7.000000E 04	20	2.000000E 04	31	1.300000E 05
10	-6.000000E 04	21	3.000000E 04	32	1.400000E 05
11	-5.000000E 04	22	4.000000E 04	33	1.500000E 05

Fig. 2.4-51 Model 0-1, 115% Load, View 3, Shroud Bottom Major Principal Stress (psi)

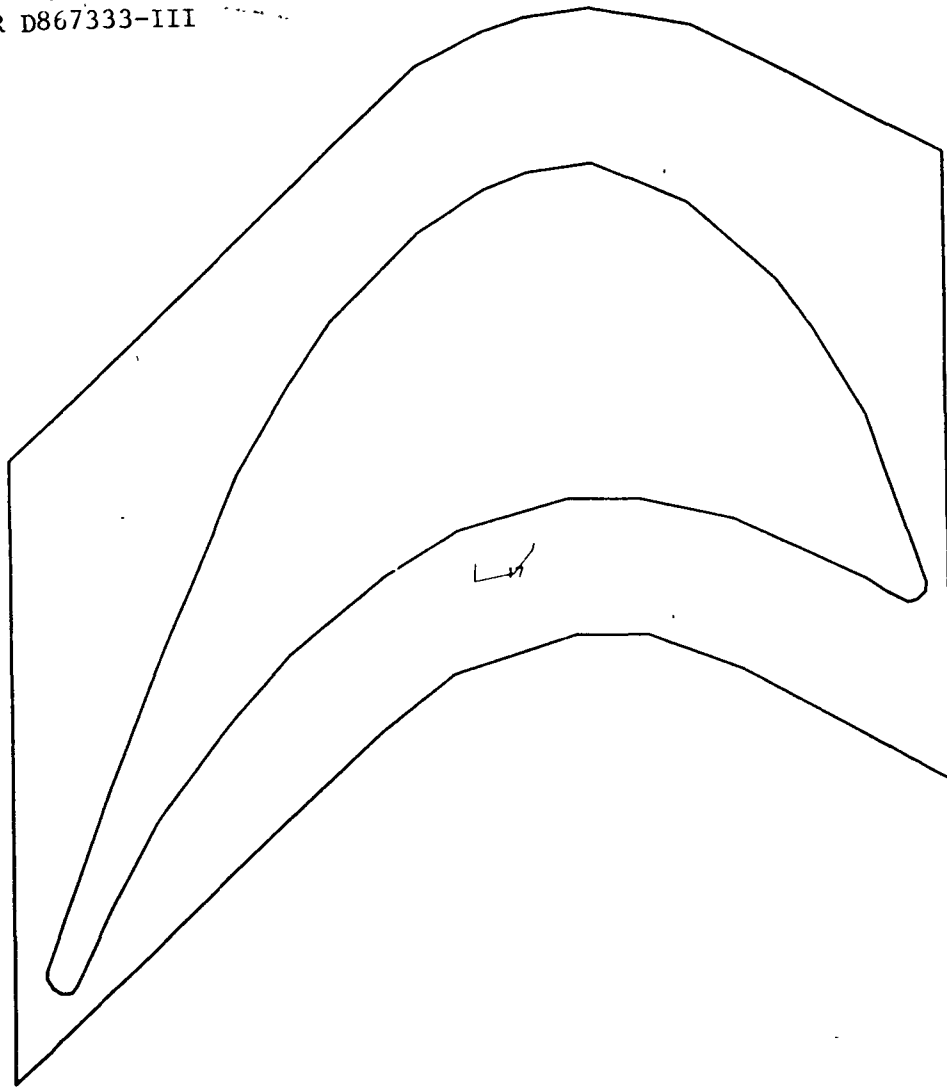

1	-1.500000E 05	12	-4.000000E 04	23	5.000000E 04
2	-1.400000E 05	13	-3.000000E 04	24	6.000000E 04
3	-1.300000E 05	14	-2.000000E 04	25	7.000000E 04
4	-1.200000E 05	15	-1.000000E 04	26	8.000000E 04
5	-1.100000E 05	16	-5.000000E 03	27	9.000000E 04
6	-1.000000E 05	17	0.0	28	1.000000E 05
7	-9.000000E 04	18	5.000000E 03	29	1.100000E 05
8	-8.000000E 04	19	1.000000E 04	30	1.200000E 05
9	-7.000000E 04	20	2.000000E 04	31	1.300000E 05
10	-6.000000E 04	21	3.000000E 04	32	1.400000E 05
11	-5.000000E 04	22	4.000000E 04	33	1.500000E 05

Fig. 2.4-52 Model 0-1, 115% Load, View 3, Shroud Bottom Minor Principal Stress (psi)

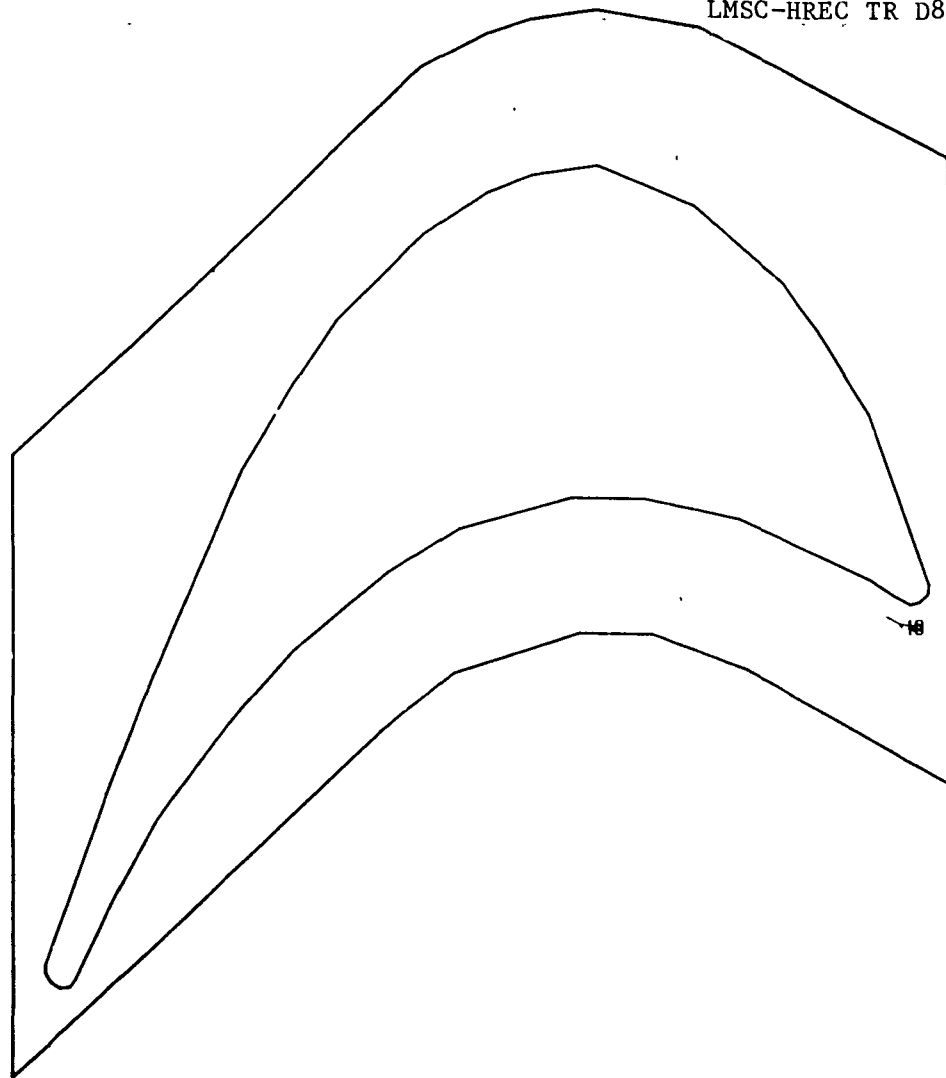

1	-1.500000E 05	12	-4.000000E 04	23	5.000000E 04
2	-1.400000E 05	13	-3.000000E 04	24	6.000000E 04
3	-1.300000E 05	14	-2.000000E 04	25	7.000000E 04
4	-1.200000E 05	15	-1.000000E 04	26	8.000000E 04
5	-1.100000E 05	16	-5.000000E 03	27	9.000000E 04
6	-1.000000E 05	17	0.0	28	1.000000E 05
7	-9.000000E 04	18	5.000000E 03	29	1.100000E 05
8	-8.000000E 04	19	1.000000E 04	30	1.200000E 05
9	-7.000000E 04	20	2.000000E 04	31	1.300000E 05
10	-6.000000E 04	21	3.000000E 04	32	1.400000E 05
11	-5.000000E 04	22	4.000000E 04	33	1.500000E 05

Fig. 2.4-53 Model 0-1, 115% Load, View 3, Shroud Bottom Maximum Principal Shear (psi)

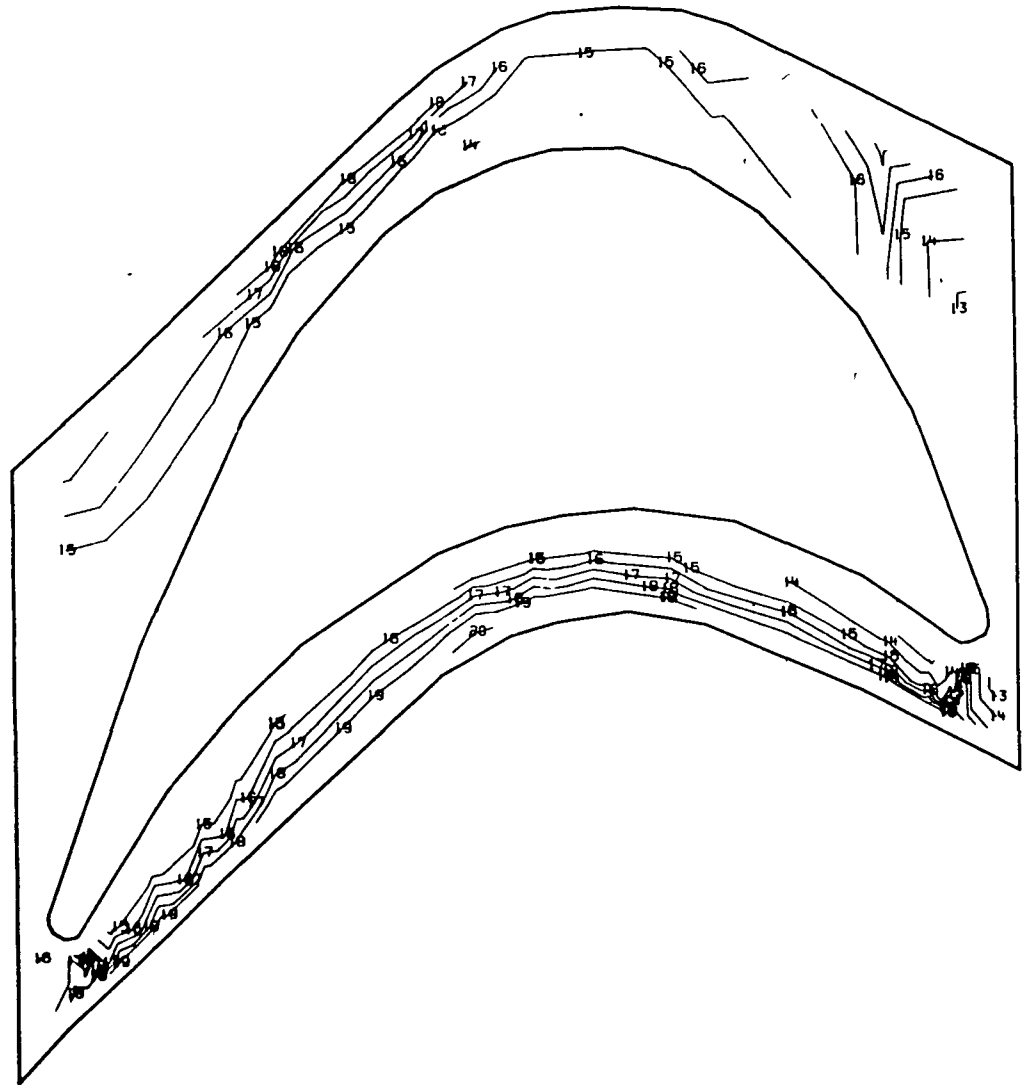

1	-1.500000E	05	12	-4.000000E	04	23	5.000000E	04
2	-1.400000E	05	13	-3.000000E	04	24	6.000000E	04
3	-1.300000E	05	14	-2.000000E	04	25	7.000000E	04
4	-1.200000E	05	15	-1.000000E	04	26	8.000000E	04
5	-1.100000E	05	16	-5.000000E	03	27	9.000000E	04
6	-1.000000E	05	17	0.0		28	1.000000E	05
7	-9.000000E	04	18	5.000000E	03	29	1.100000E	05
8	-8.000000E	04	19	1.000000E	04	30	1.200000E	05
9	-7.000000E	04	20	2.000000E	04	31	1.300000E	05
10	-6.000000E	04	21	3.000000E	04	32	1.400000E	05
11	-5.000000E	04	22	4.000000E	04	33	1.500000E	05

Fig. 2.4-54 Model Q-1, FPL Load, View 3, Platform Top Major Principal Stress (psi)

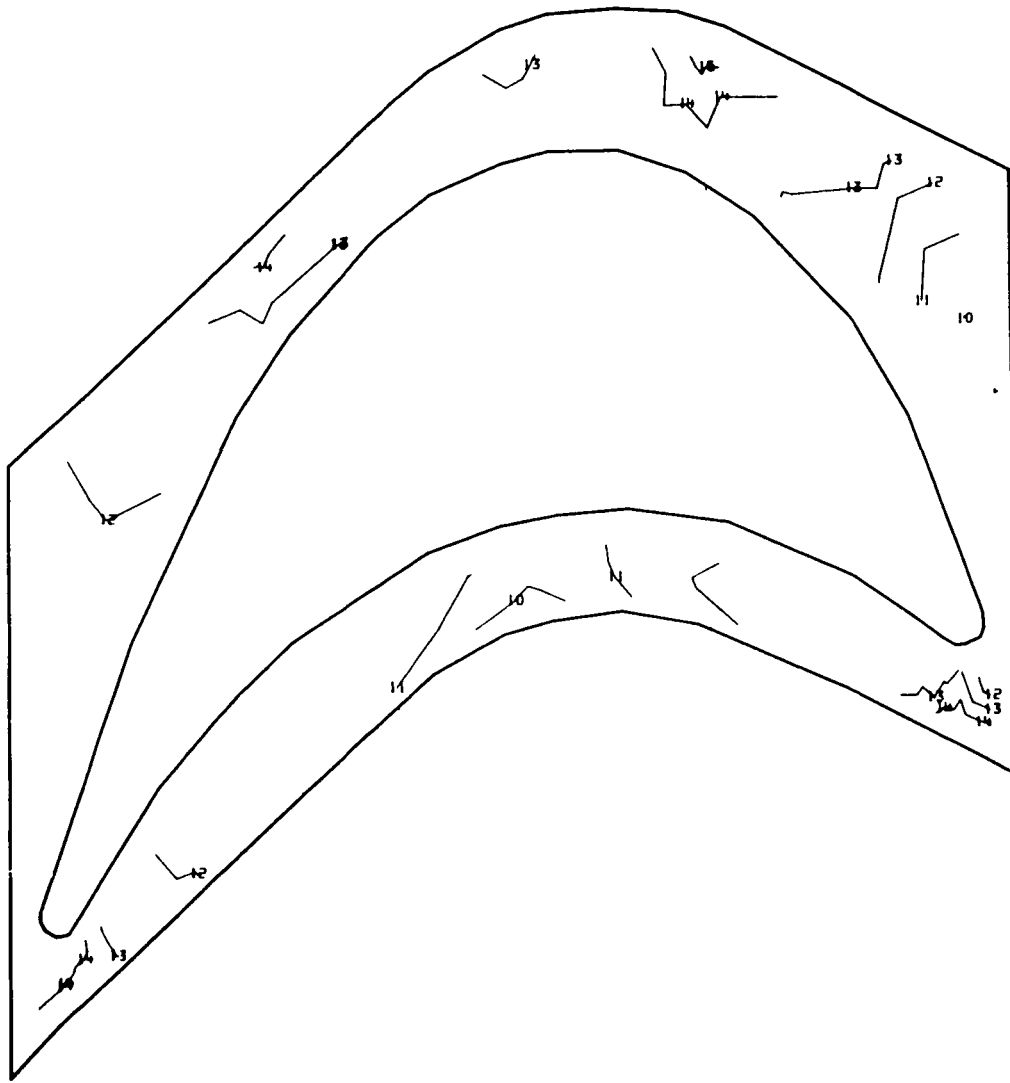

1	-1.500000E 05	12	-4.000000E 04	23	5.000000E 04
2	-1.400000E 05	13	-3.000000E 04	24	6.000000E 04
3	-1.300000E 05	14	-2.000000E 04	25	7.000000E 04
4	-1.200000E 05	15	-1.000000E 04	26	8.000000E 04
5	-1.100000E 05	16	-5.000000E 03	27	9.000000E 04
6	-1.000000E 05	17	0.0	28	1.000000E 05
7	-9.000000E 04	18	5.000000E 03	29	1.100000E 05
8	-8.000000E 04	19	1.000000E 04	30	1.200000E 05
9	-7.000000E 04	20	2.000000E 04	31	1.300000E 05
10	-6.000000E 04	21	3.000000E 04	32	1.400000E 05
11	-5.000000E 04	22	4.000000E 04	33	1.500000E 05

Fig. 2.4-55 Model 0-1, FPL Load, View 3, Platform Top Minor Principal Stress (psi)

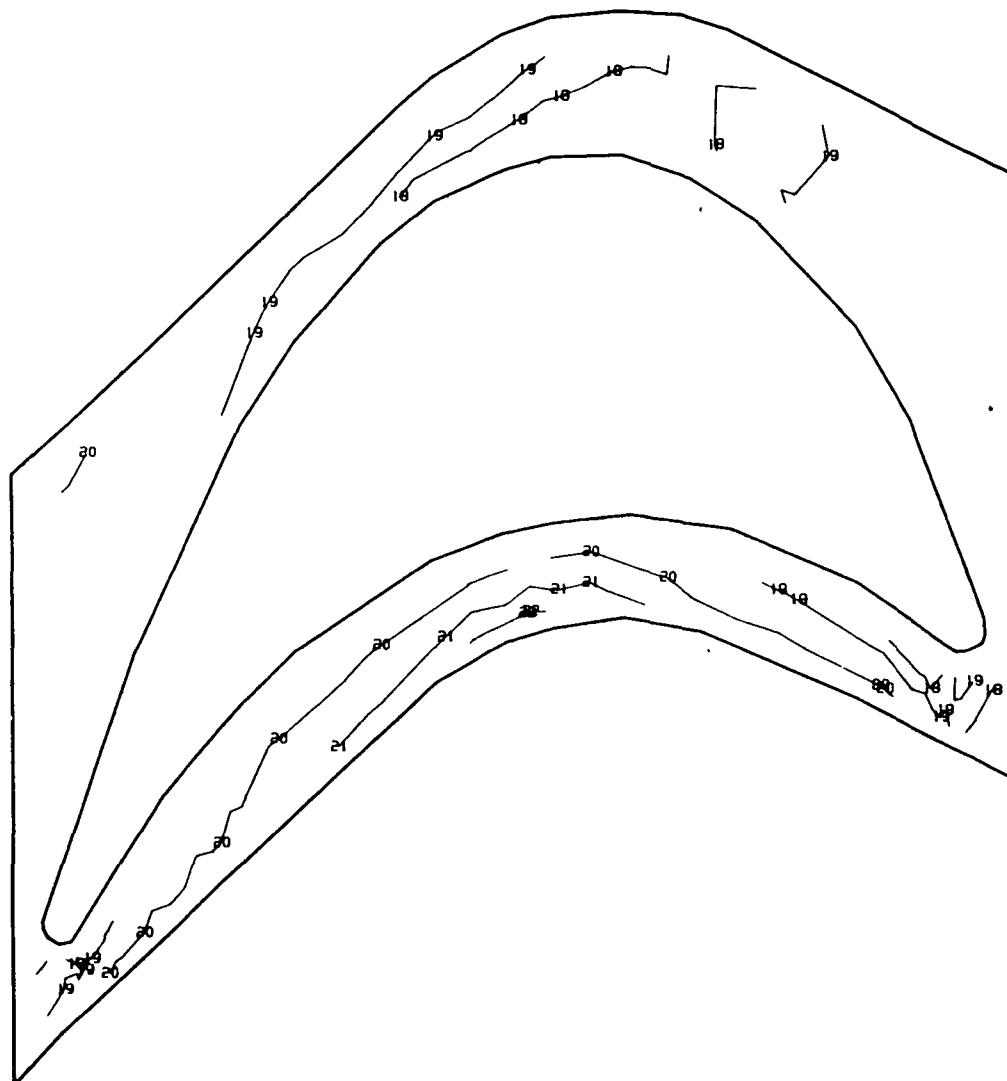

1	-1.500000E	05	12	-4.000000E	04	23	5.000000E	04
2	-1.400000E	05	13	-3.000000E	04	24	6.000000E	04
3	-1.300000E	05	14	-2.000000E	04	25	7.000000E	04
4	-1.200000E	05	15	-1.000000E	04	26	8.000000E	04
5	-1.100000E	05	16	-5.000000E	03	27	9.000000E	04
6	-1.000000E	05	17	0.0		28	1.000000E	05
7	-9.000000E	04	18	5.000000E	03	29	1.100000E	05
8	-8.000000E	04	19	1.000000E	04	30	1.200000E	05
9	-7.000000E	04	20	2.000000E	04	31	1.300000E	05
10	-6.000000E	04	21	3.000000E	04	32	1.400000E	05
11	-5.000000E	04	22	4.000000E	04	33	1.500000E	05

Fig. 2.4-56 Model 0-1, FPL Load, View 3, Platform Top Maximum Principal Shear (psi)

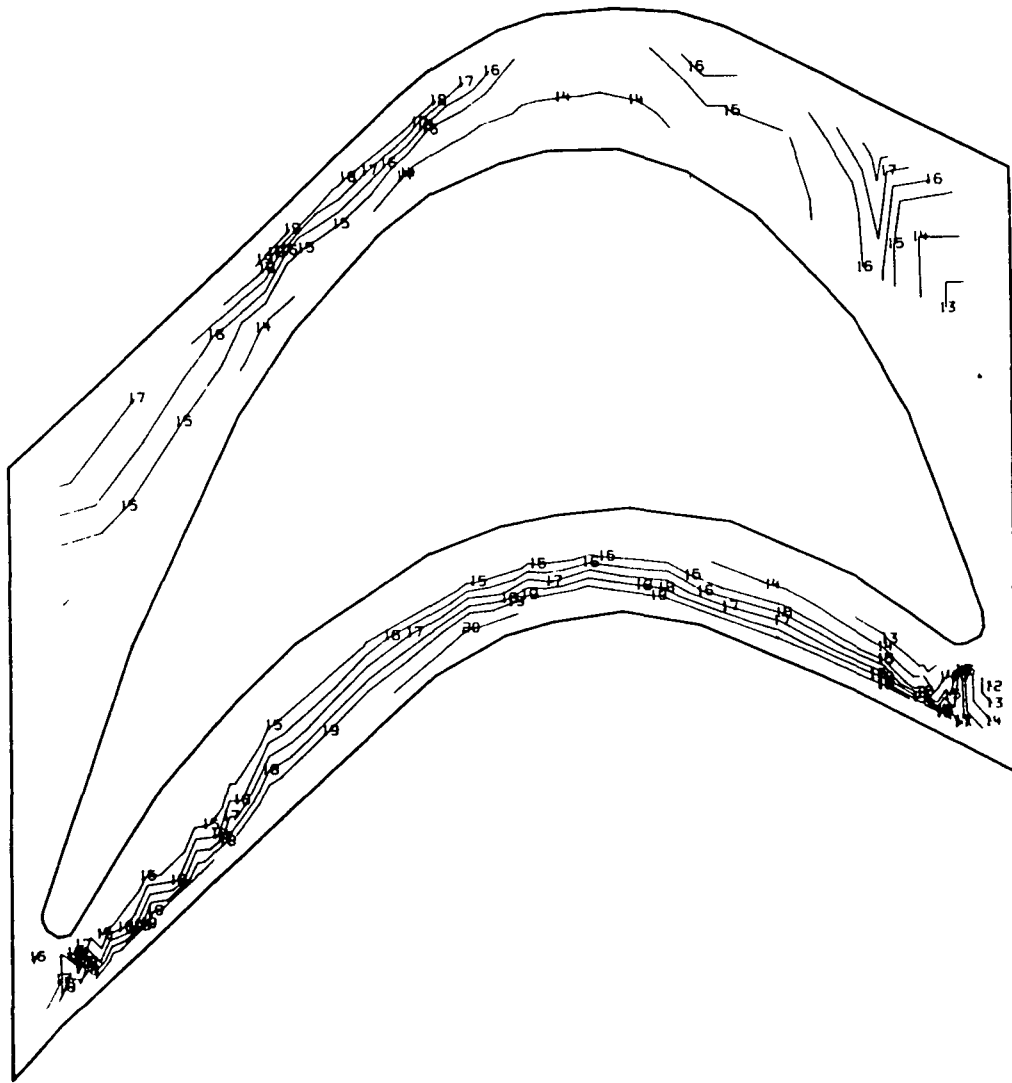

1	-1.500000E 05	12	-4.000000E 04	23	5.000000E 04
2	-1.400000E 05	13	-3.000000E 04	24	6.000000E 04
3	-1.300000E 05	14	-2.000000E 04	25	7.000000E 04
4	-1.200000E 05	15	-1.000000E 04	26	8.000000E 04
5	-1.100000E 05	16	-5.000000E 03	27	9.000000E 04
6	-1.000000E 05	17	0.0	28	1.000000E 05
7	-9.000000E 04	18	5.000000E 03	29	1.100000E 05
8	-8.000000E 04	19	1.000000E 04	30	1.200000E 05
9	-7.000000E 04	20	2.000000E 04	31	1.300000E 05
10	-6.000000E 04	21	3.000000E 04	32	1.400000E 05
11	-5.000000E 04	22	4.000000E 04	33	1.500000E 05

Fig. 2.4-57 Model 0-1, 115% Load, View 3, Platform Stress Major Principal Stress (psi)

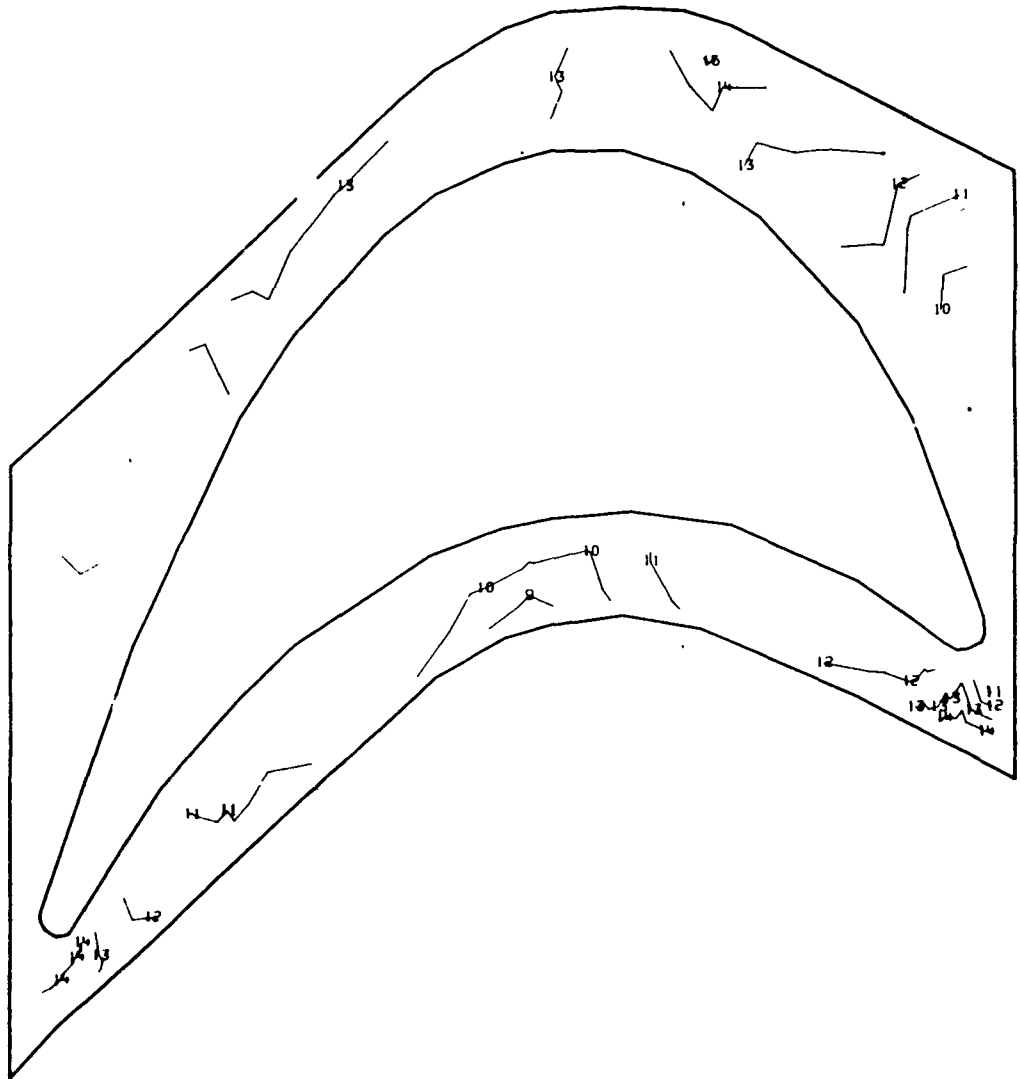

1	-1.500000E 05	12	-4.000000E 04	23	5.000000E 04
2	-1.400000E 05	13	-3.000000E 04	24	6.000000E 04
3	-1.300000E 05	14	-2.000000E 04	25	7.000000E 04
4	-1.200000E 05	15	-1.000000E 04	26	8.000000E 04
5	-1.100000E 05	16	-5.000000E 03	27	9.000000E 04
6	-1.000000E 05	17	0.0	28	1.000000E 05
7	-9.000000E 04	18	5.000000E 03	29	1.100000E 05
8	-8.000000E 04	19	1.000000E 04	30	1.200000E 05
9	-7.000000E 04	20	2.000000E 04	31	1.300000E 05
10	-6.000000E 04	21	3.000000E 04	32	1.400000E 05
11	-5.000000E 04	22	4.000000E 04	33	1.500000E 05

Fig. 2.4-58 Model 0-1, 115% Load, View 3, Platform Top Minor Principal Stress (psi)

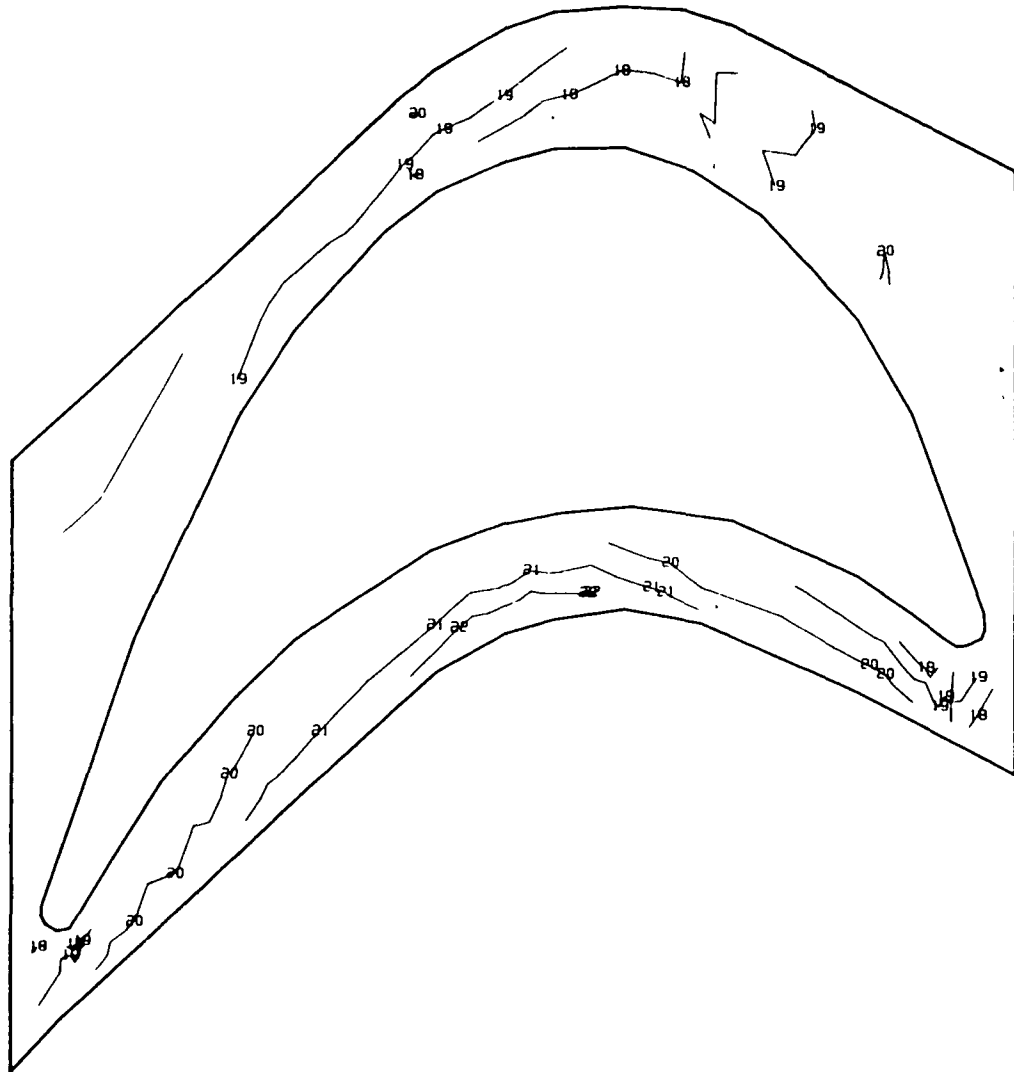

1	-1.500000E 05	12	-4.000000E 04	23	5.000000E 04
2	-1.400000E 05	13	-3.000000E 04	24	6.000000E 04
3	-1.300000E 05	14	-2.000000E 04	25	7.000000E 04
4	-1.200000E 05	15	-1.000000E 04	26	8.000000E 04
5	-1.100000E 05	16	-5.000000E 03	27	9.000000E 04
6	-1.000000E 05	17	0.0	28	1.000000E 05
7	-9.000000E 04	18	5.000000E 03	29	1.100000E 05
8	-8.000000E 04	19	1.000000E 04	30	1.200000E 05
9	-7.000000E 04	20	2.000000E 04	31	1.300000E 05
10	-6.000000E 04	21	3.000000E 04	32	1.400000E 05
11	-5.000000E 04	22	4.000000E 04	33	1.500000E 05

Fig. 2.4-59 Model 0-1, 115% Load, View 3, Platform Top Maximum Principal Shear (psi)

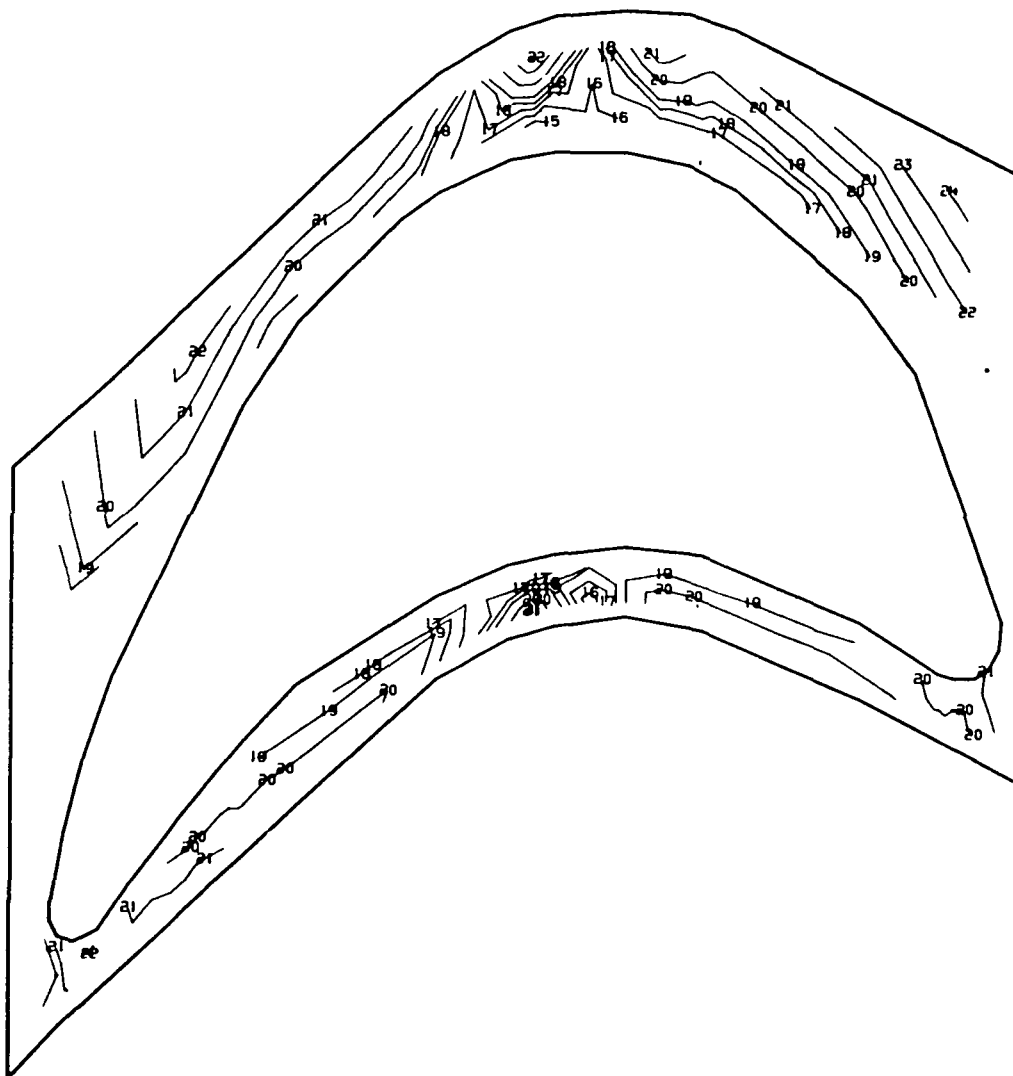

1	-1.500000E 05	12	-4.000000E 04	23	5.000000E 04
2	-1.400000E 05	13	-3.000000E 04	24	6.000000E 04
3	-1.300000E 05	14	-2.000000E 04	25	7.000000E 04
4	-1.200000E 05	15	-1.000000E 04	26	8.000000E 04
5	-1.100000E 05	16	-5.000000E 03	27	9.000000E 04
6	-1.000000E 05	17	0.0	28	1.000000E 05
7	-9.000000E 04	18	5.000000E 03	29	1.100000E 05
8	-8.000000E 04	19	1.000000E 04	30	1.200000E 05
9	-7.000000E 04	20	2.000000E 04	31	1.300000E 05
10	-6.000000E 04	21	3.000000E 04	32	1.400000E 05
11	-5.000000E 04	22	4.000000E 04	33	1.500000E 05

Fig. 2.4-60 Model 0-1, FPL Load, View 3, Platform Bottom Major Principal Stress (psi)

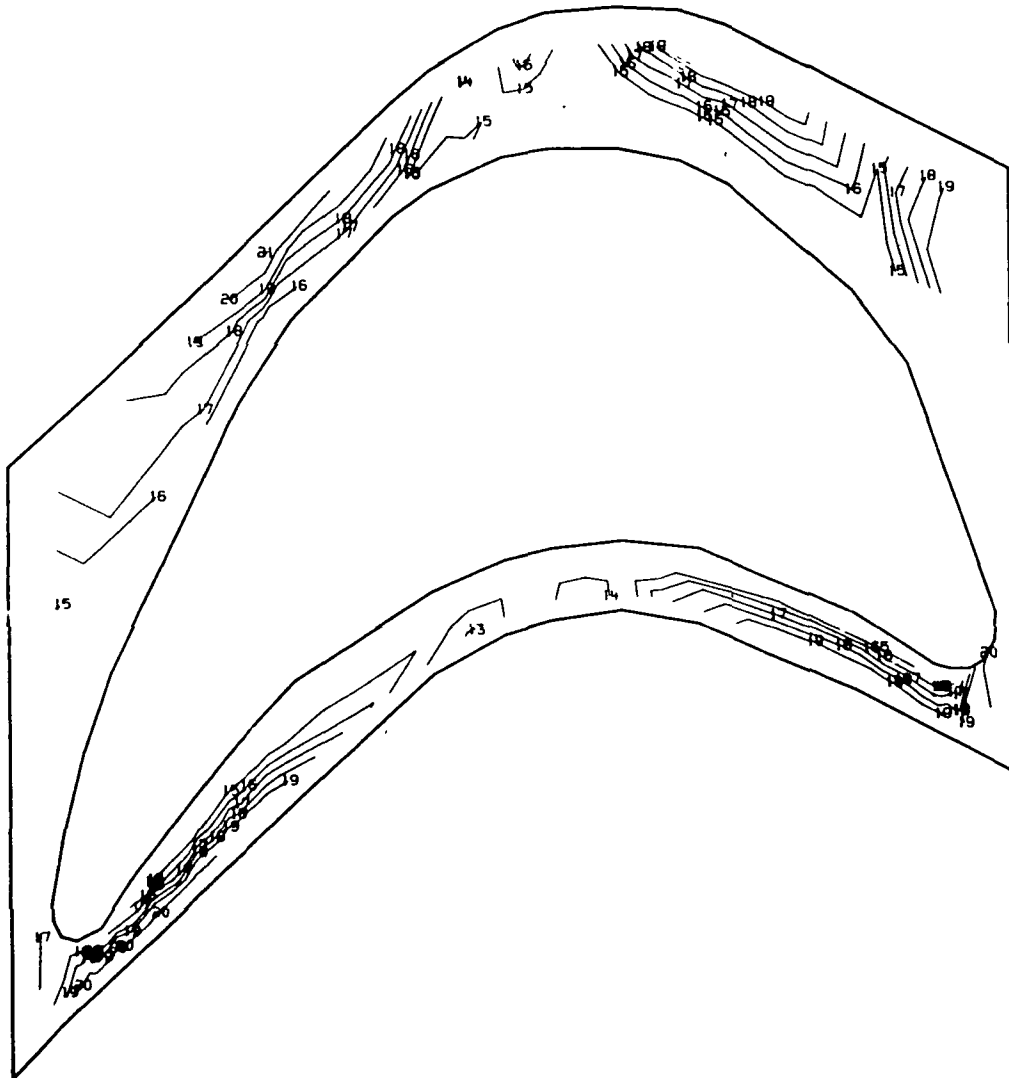

1	-1.500000E 05	05	12	-4.000000E 04	04	23	5.000000E 04	04
2	-1.400000E 05	05	13	-3.000000E 04	04	24	6.000000E 04	04
3	-1.300000E 05	05	14	-2.000000E 04	04	25	7.000000E 04	04
4	-1.200000E 05	05	15	-1.000000E 04	04	26	8.000000E 04	04
5	-1.100000E 05	05	16	-5.000000E 03	03	27	9.000000E 04	04
6	-1.000000E 05	05	17	0.0		28	1.000000E 05	05
7	-9.000000E 04	04	18	5.000000E 03	03	29	1.100000E 05	05
8	-8.000000E 04	04	19	1.000000E 04	04	30	1.200000E 05	05
9	-7.000000E 04	04	20	2.000000E 04	04	31	1.300000E 05	05
10	-6.000000E 04	04	21	3.000000E 04	04	32	1.400000E 05	05
11	-5.000000E 04	04	22	4.000000E 04	04	33	1.500000E 05	05

Fig. 2.4-61 Model 0-1, FPL Load, View 3, Platform Bottom Minor Principal Stress (psi)

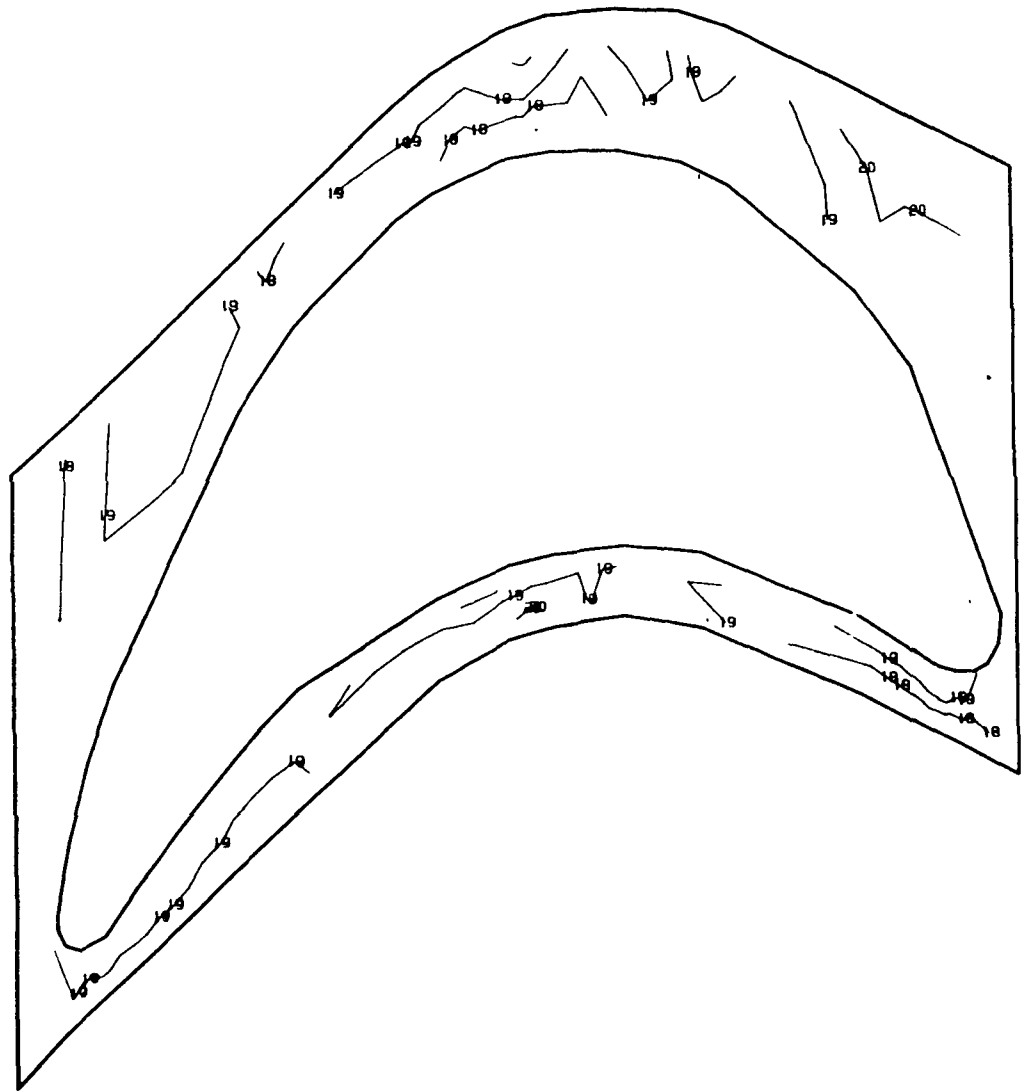

1	-1.500000E	05	12	-4.000000E	04	23	5.000000E	04
2	-1.400000E	05	13	-3.000000E	04	24	6.000000E	04
3	-1.300000E	05	14	-2.000000E	04	25	7.000000E	04
4	-1.200000E	05	15	-1.000000E	04	26	8.000000E	04
5	-1.100000E	05	16	-5.000000E	03	27	9.000000E	04
6	-1.000000E	05	17	0.0		28	1.000000E	05
7	-9.000000E	04	18	5.000000E	03	29	1.100000E	05
8	-8.000000E	04	19	1.000000E	04	30	1.200000E	05
9	-7.000000E	04	20	2.000000E	04	31	1.300000E	05
10	-6.000000E	04	21	3.000000E	04	32	1.400000E	05
11	-5.000000E	04	22	4.000000E	04	33	1.500000E	05

Fig. 2.4-62 Model 0-1, FPL Load, View 3, Platform Bottom Maximum Principal Shear (psi)

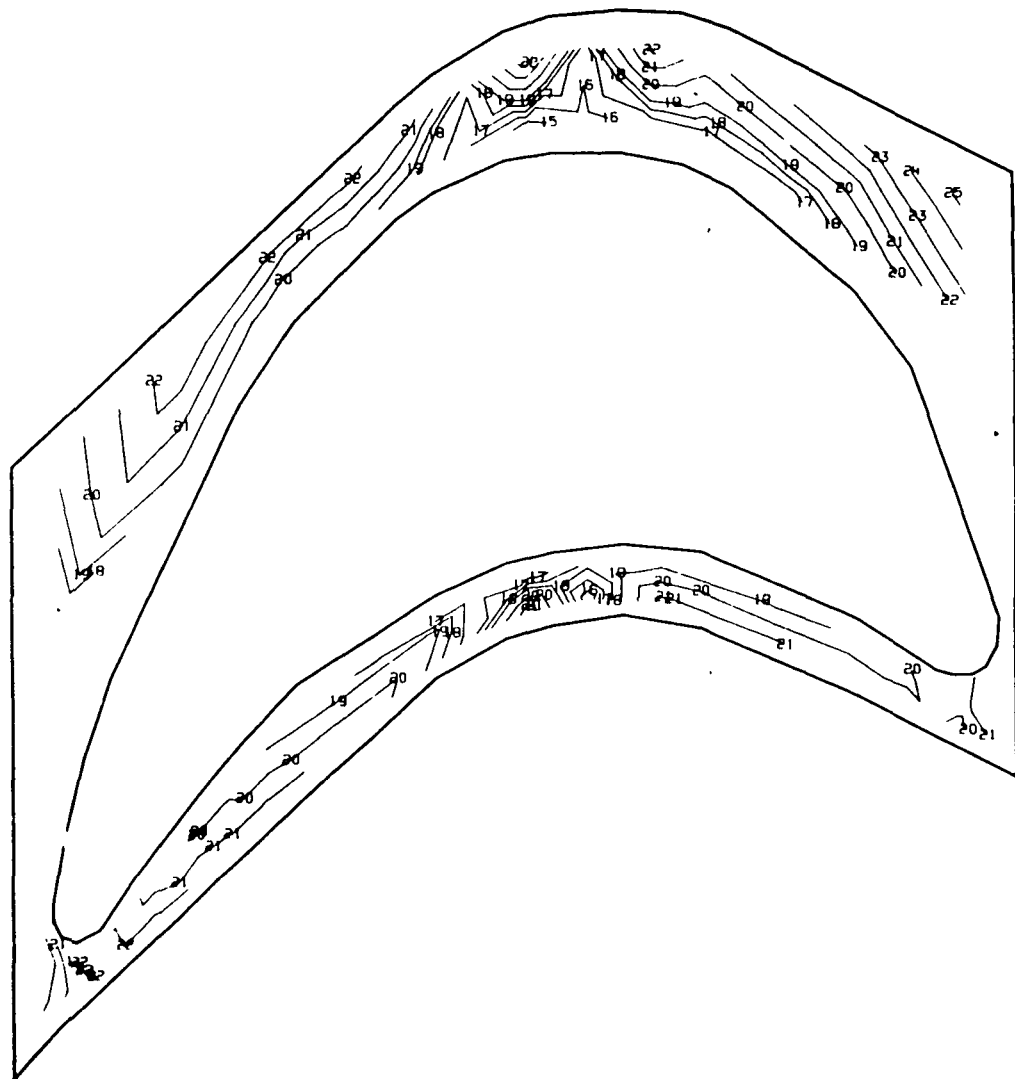

1	-1.500000E 05	05	12	-4.000000E 04	04	23	5.000000E 04	04
2	-1.400000E 05	05	13	-3.000000E 04	04	24	6.000000E 04	04
3	-1.300000E 05	05	14	-2.000000E 04	04	25	7.000000E 04	04
4	-1.200000E 05	05	15	-1.000000E 04	04	26	8.000000E 04	04
5	-1.100000E 05	05	16	-5.000000E 03	03	27	9.000000E 04	04
6	-1.000000E 05	05	17	0.0		28	1.000000E 05	05
7	-9.000000E 04	04	18	5.000000E 03	03	29	1.100000E 05	05
8	-8.000000E 04	04	19	1.000000E 04	04	30	1.200000E 05	05
9	-7.000000E 04	04	20	2.000000E 04	04	31	1.300000E 05	05
10	-6.000000E 04	04	21	3.000000E 04	04	32	1.400000E 05	05
11	-5.000000E 04	04	22	4.000000E 04	04	33	1.500000E 05	05

Fig. 2.4-63 Model 0-1, 115% Load, View 3, Platform Bottom Major Principal Stress (psi)

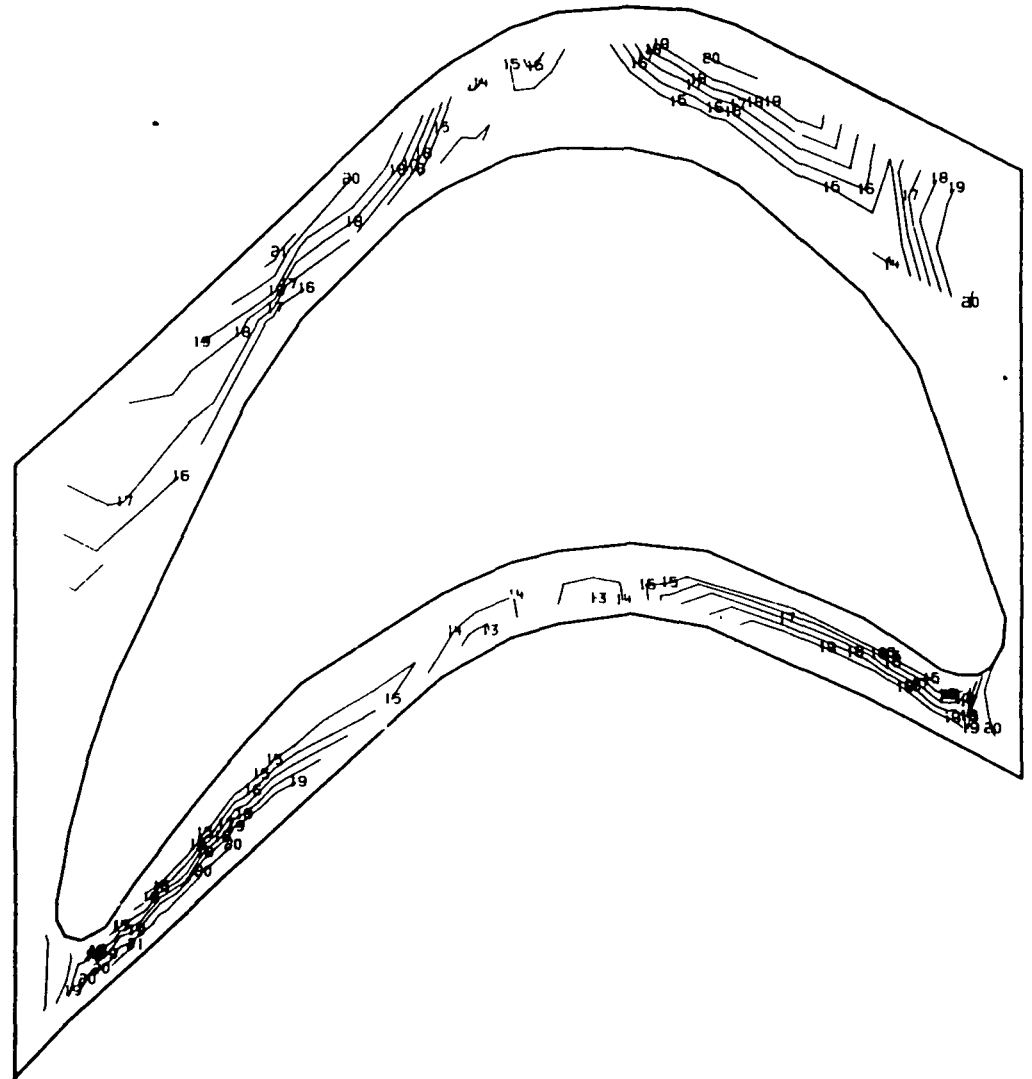

1	-1.500000E 05	05	12	-4.000000E 04	04	23	5.000000E 04	04
2	-1.400000E 05	05	13	-3.000000E 04	04	24	6.000000E 04	04
3	-1.300000E 05	05	14	-2.000000E 04	04	25	7.000000E 04	04
4	-1.200000E 05	05	15	-1.000000E 04	04	26	8.000000E 04	04
5	-1.100000E 05	05	16	-5.000000E 03	03	27	9.000000E 04	04
6	-1.000000E 05	05	17	0.0		28	1.000000E 05	05
7	-9.000000E 04	04	18	5.000000E 03	03	29	1.100000E 05	05
8	-8.000000E 04	04	19	1.000000E 04	04	30	1.200000E 05	05
9	-7.000000E 04	04	20	2.000000E 04	04	31	1.300000E 05	05
10	-6.000000E 04	04	21	3.000000E 04	04	32	1.400000E 05	05
11	-5.000000E 04	04	22	4.000000E 04	04	33	1.500000E 05	05

Fig. 2.4-64 Model 0-1, 115% Load, View 3, Platform Bottom Minor Principal Stress (psi)

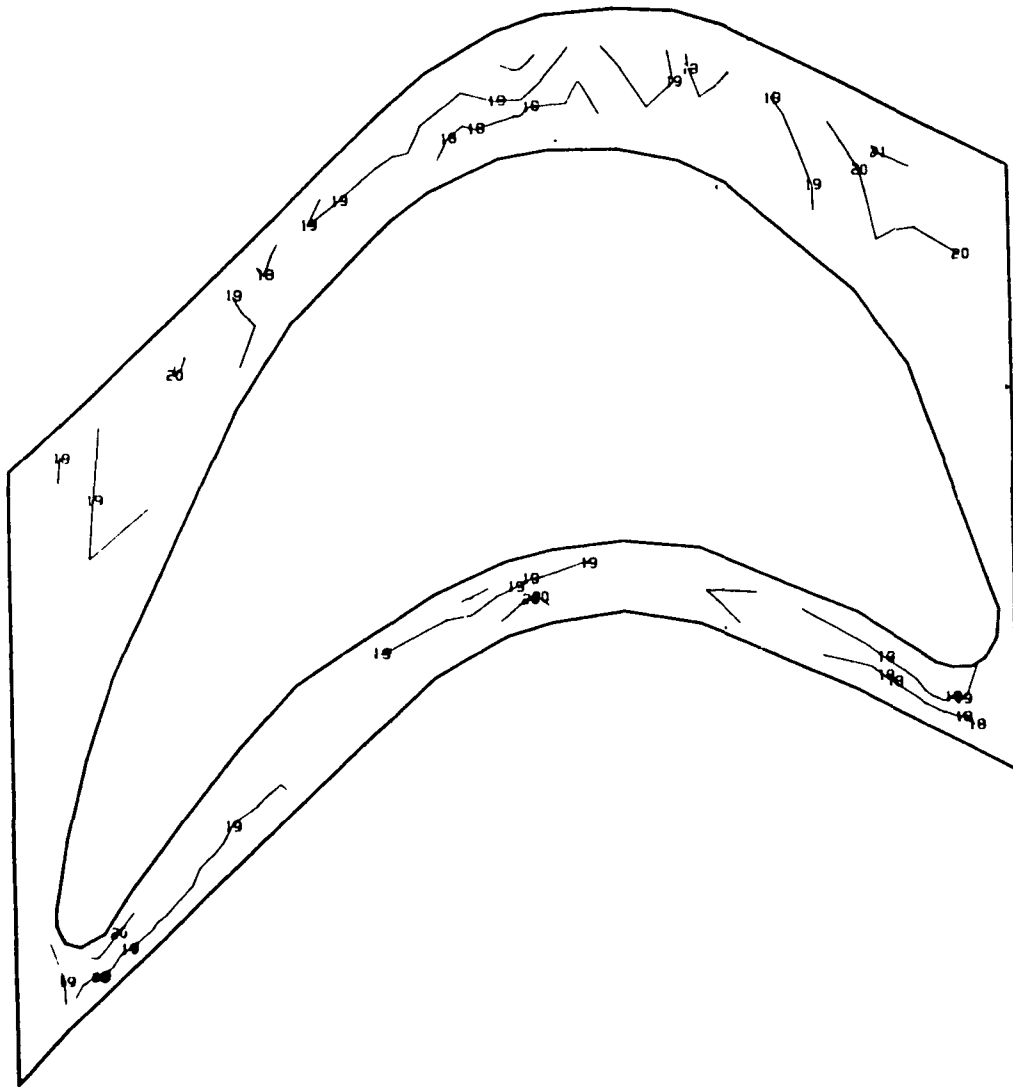

1	-1.500000E 05	12	-4.000000E 04	23	5.000000E 04
2	-1.400000E 05	13	-3.000000E 04	24	6.000000E 04
3	-1.300000E 05	14	-2.000000E 04	25	7.000000E 04
4	-1.200000E 05	15	-1.000000E 04	26	8.000000E 04
5	-1.100000E 05	16	-5.000000E 03	27	9.000000E 04
6	-1.000000E 05	17	0.0	28	1.000000E 05
7	-9.000000E 04	18	5.000000E 03	29	1.100000E 05
8	-8.000000E 04	19	1.000000E 04	30	1.200000E 05
9	-7.000000E 04	20	2.000000E 04	31	1.300000E 05
10	-6.000000E 04	21	3.000000E 04	32	1.400000E 05
11	-5.000000E 04	22	4.000000E 04	33	1.500000E 05

Fig. 2.4-65 Model 0-1, 115% Load, View 3, Platform Bottom Maximum Principal Shear (psi)

2.5 HPOTP SECOND STAGE TURBINE BLADE TEMPERATURES AND STRESSES
 AT FPL AND 115% RPL

Surface temperatures are shown in Figs. 2.5-1 through 2.5-16. Surface stresses are shown in Figs. 2.5-17 through 2.5-64.

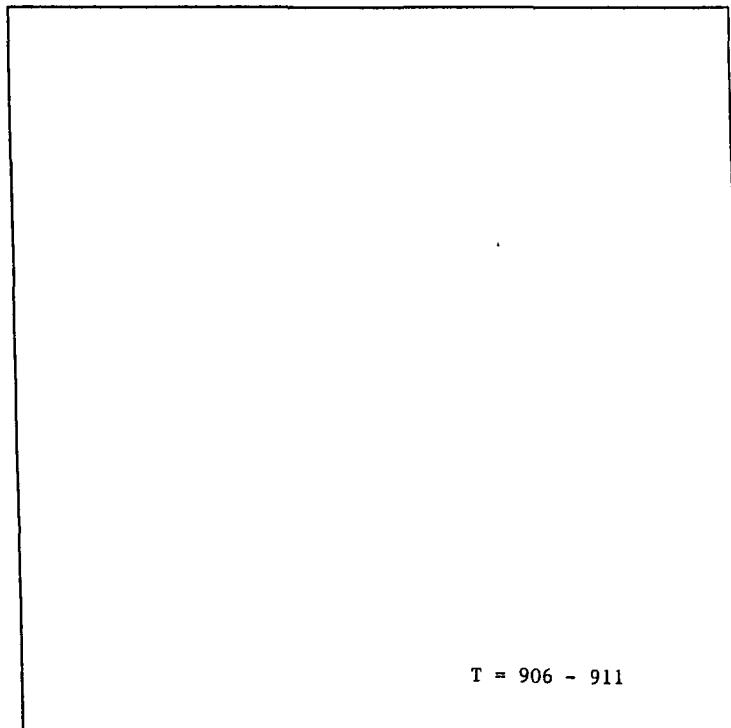

1 -3.000000E 02	14 3.500000E 02	27 1.000000E 03
2 -2.500000E 02	15 4.000000E 02	28 1.050000E 03
3 -2.000000E 02	16 4.500000E 02	29 1.100000E 03
4 -1.500000E 02	17 5.000000E 02	30 1.150000E 03
5 -1.000000E 02	18 5.500000E 02	31 1.200000E 03
6 -5.000000E 01	19 6.000000E 02	32 1.250000E 03
7 0.0	20 6.500000E 02	33 1.300000E 03
8 5.000000E 01	21 7.000000E 02	34 1.350000E 03
9 1.000000E 02	22 7.500000E 02	35 1.400000E 03
10 1.500000E 02	23 8.000000E 02	36 1.450000E 03
11 2.000000E 02	24 8.500000E 02	37 1.500000E 03
12 2.500000E 02	25 9.000000E 02	38 1.550000E 03
13 3.000000E 02	26 9.500000E 02	39 1.600000E 03

Fig. 2.5-1 Model 0-2, FPL Load, View 1, Airfoil Pressure Side Steady State Surface Temperatures (F)

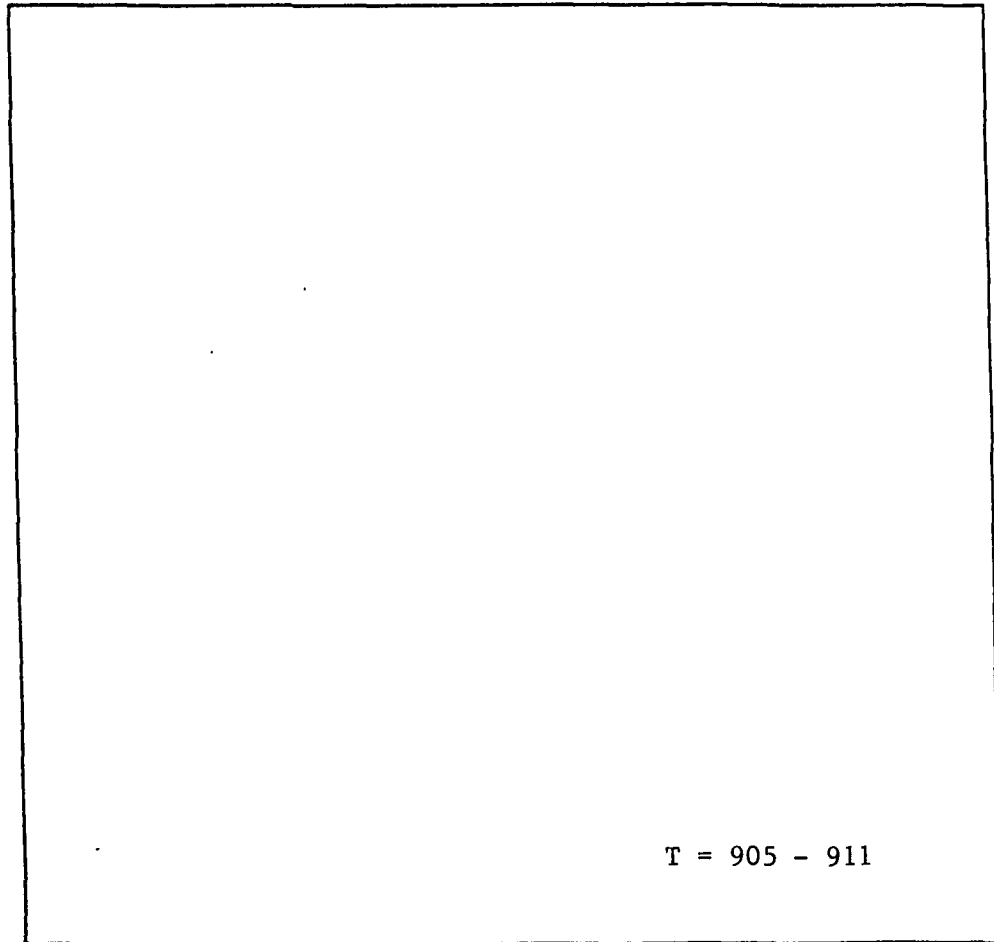

1	-3.000000E 02	14	3.500000E 02	27	1.000000E 03
2	-2.500000E 02	15	4.000000E 02	28	1.050000E 03
3	-2.000000E 02	16	4.500000E 02	29	1.100000E 03
4	-1.500000E 02	17	5.000000E 02	30	1.150000E 03
5	-1.000000E 02	18	5.500000E 02	31	1.200000E 03
6	-5.000000E 01	19	6.000000E 02	32	1.250000E 03
7	0.0	20	6.500000E 02	33	1.300000E 03
8	5.000000E 01	21	7.000000E 02	34	1.350000E 03
9	1.000000E 02	22	7.500000E 02	35	1.400000E 03
10	1.500000E 02	23	8.000000E 02	36	1.450000E 03
11	2.000000E 02	24	8.500000E 02	37	1.500000E 03
12	2.500000E 02	25	9.000000E 02	38	1.550000E 03
13	3.000000E 02	26	9.500000E 02	39	1.600000E 03

Fig. 2.5-2 Model 0-2, FPL Load, View 1, Airfoil Suction Side Steady State Surface Temperatures (F)

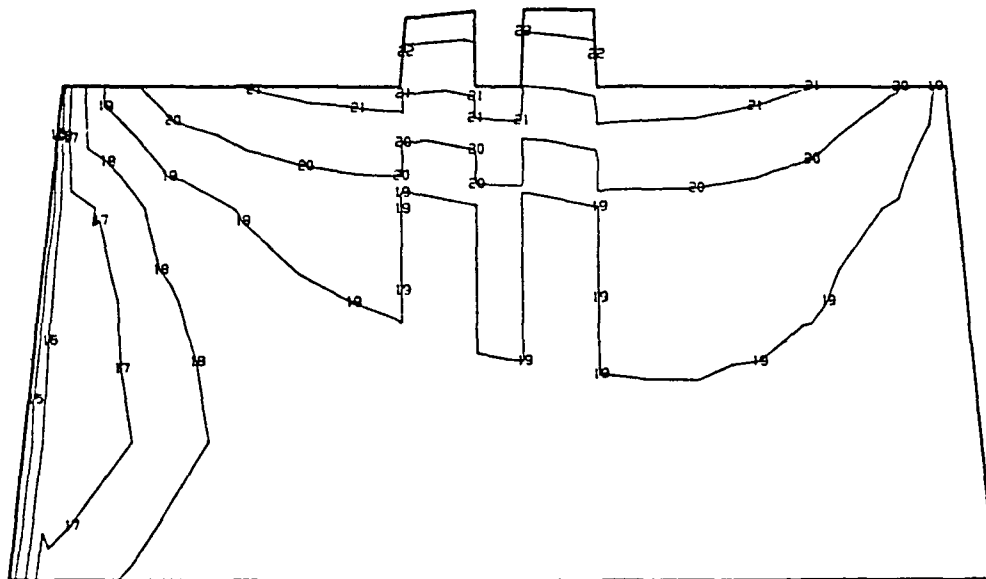

1	-3.000000E 02	14	3.500000E 02	27	1.000000E 03
2	-2.500000E 02	15	4.000000E 02	28	1.050000E 03
3	-2.000000E 02	16	4.500000E 02	29	1.100000E 03
4	-1.500000E 02	17	5.000000E 02	30	1.150000E 03
5	-1.000000E 02	18	5.500000E 02	31	1.200000E 03
6	-5.000000E 01	19	6.000000E 02	32	1.250000E 03
7	0.0	20	6.500000E 02	33	1.300000E 03
8	5.000000E 01	21	7.000000E 02	34	1.350000E 03
9	1.000000E 02	22	7.500000E 02	35	1.400000E 03
10	1.500000E 02	23	8.000000E 02	36	1.450000E 03
11	2.000000E 02	24	8.500000E 02	37	1.500000E 03
12	2.500000E 02	25	9.000000E 02	38	1.550000E 03
13	3.000000E 02	26	9.500000E 02	39	1.600000E 03

Fig. 2.5-3 Model 0-2, FPL Load, View 2, Shank Pressure Side Steady State Surface Temperatures (F)

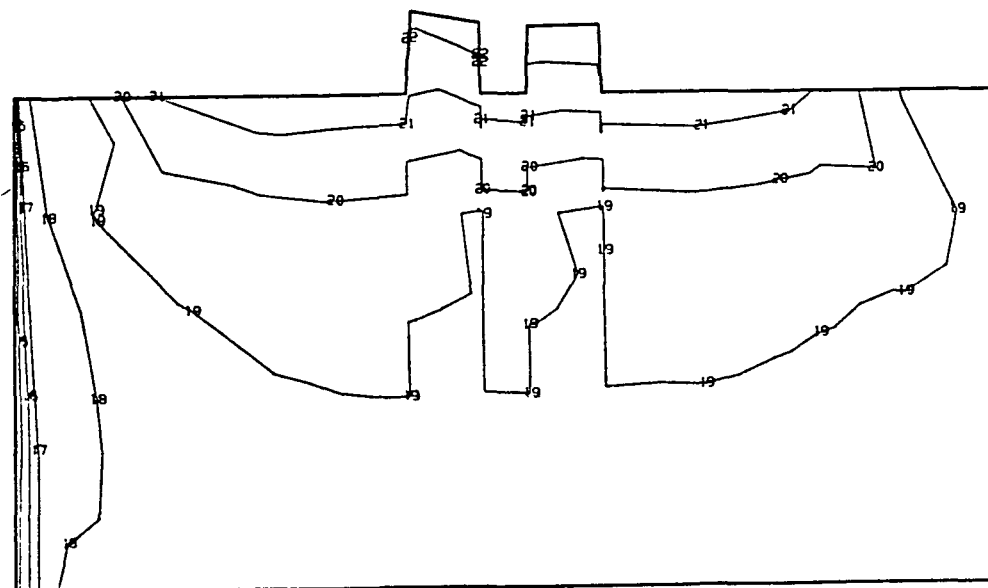

1	-3.000000E 02	14	3.500000E 02	27	1.000000E 03
2	-2.500000E 02	15	4.000000E 02	28	1.050000E 03
3	-2.000000E 02	16	4.500000E 02	29	1.100000E 03
4	-1.500000E 02	17	5.000000E 02	30	1.150000E 03
5	-1.000000E 02	18	5.500000E 02	31	1.200000E 03
6	-5.000000E 01	19	6.000000E 02	32	1.250000E 03
7	0.0	20	6.500000E 02	33	1.300000E 03
8	5.000000E 01	21	7.000000E 02	34	1.350000E 03
9	1.000000E 02	22	7.500000E 02	35	1.400000E 03
10	1.500000E 02	23	8.000000E 02	36	1.450000E 03
11	2.000000E 02	24	8.500000E 02	37	1.500000E 03
12	2.500000E 02	25	9.000000E 02	38	1.550000E 03
13	3.000000E 02	26	9.500000E 02	39	1.600000E 03

Fig. 2.5-4 Model 0-2, FPL Load, View 2, Shank Suction Side, Steady State Surface Temperatures (F)

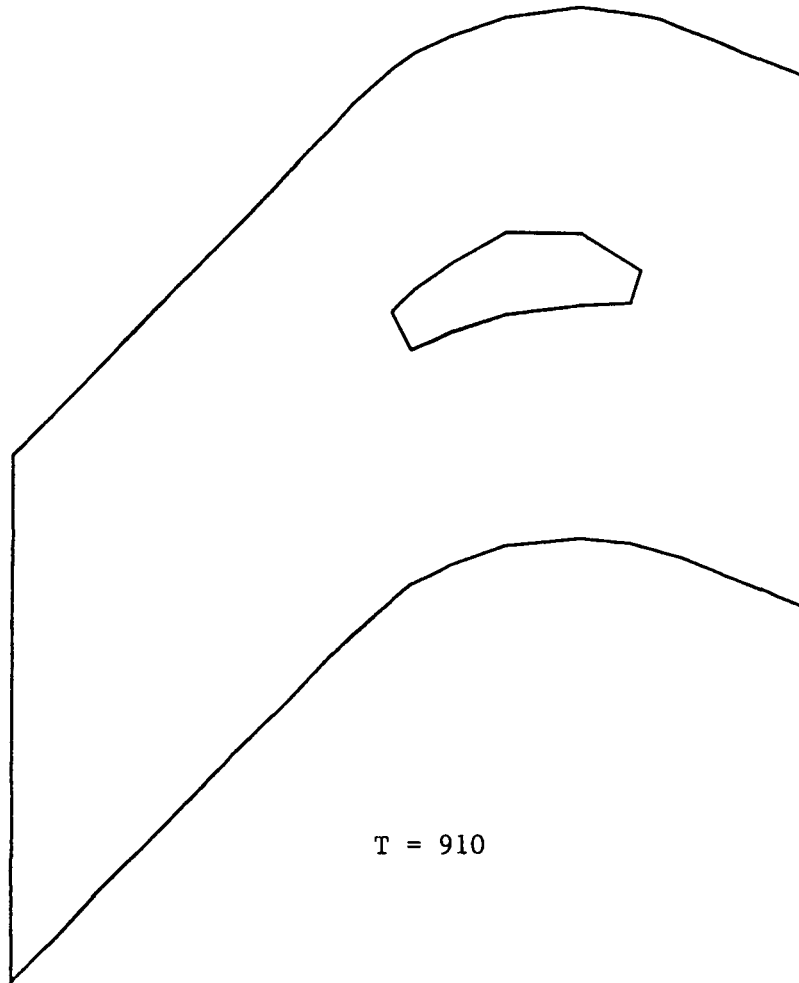

1	-3.000000E 02	14	3.500000E 02	27	1.000000E 03
2	-2.500000E 02	15	4.000000E 02	28	1.050000E 03
3	-2.000000E 02	16	4.500000E 02	29	1.100000E 03
4	-1.500000E 02	17	5.000000E 02	30	1.150000E 03
5	-1.000000E 02	18	5.500000E 02	31	1.200000E 03
6	-5.000000E 01	19	6.000000E 02	32	1.250000E 03
7	0.0	20	6.500000E 02	33	1.300000E 03
8	5.000000E 01	21	7.000000E 02	34	1.350000E 03
9	1.000000E 02	22	7.500000E 02	35	1.400000E 03
10	1.500000E 02	23	8.000000E 02	36	1.450000E 03
11	2.000000E 02	24	8.500000E 02	37	1.500000E 03
12	2.500000E 02	25	9.000000E 02	38	1.550000E 03
13	3.000000E 02	26	9.500000E 02	39	1.600000E 03

Fig. 2.5-5 Model 0-2, FPL Load, View 3 Shroud Top Steady State Surface Temperatures (F)

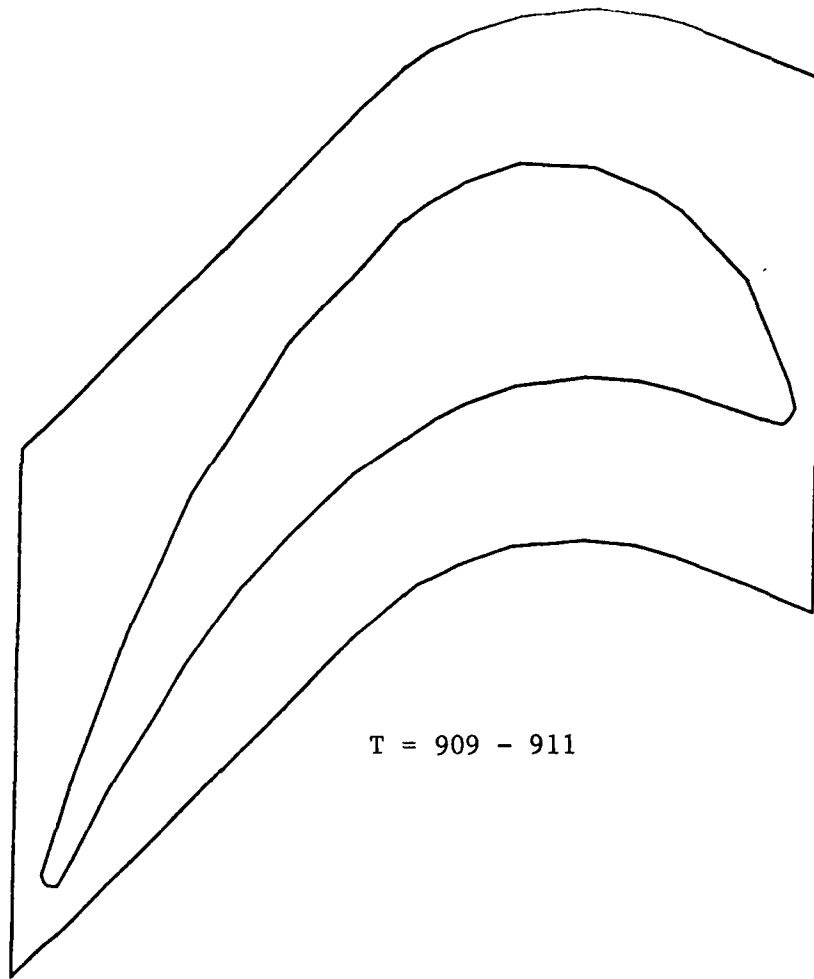

T = 909 - 911

1	-3.000000E 02	14	3.500000E 02	27	1.000000E 03
2	-2.500000E 02	15	4.000000E 02	28	1.050000E 03
3	-2.000000E 02	16	4.500000E 02	29	1.100000E 03
4	-1.500000E 02	17	5.000000E 02	30	1.150000E 03
5	-1.000000E 02	18	5.500000E 02	31	1.200000E 03
6	-5.000000E 01	19	6.000000E 02	32	1.250000E 03
7	0.0	20	6.500000E 02	33	1.300000E 03
8	5.000000E 01	21	7.000000E 02	34	1.350000E 03
9	1.000000E 02	22	7.500000E 02	35	1.400000E 03
10	1.500000E 02	23	8.000000E 02	36	1.450000E 03
11	2.000000E 02	24	8.500000E 02	37	1.500000E 03
12	2.500000E 02	25	9.000000E 02	38	1.550000E 03
13	3.000000E 02	26	9.500000E 02	39	1.600000E 03

Fig. 2.5-6 Model 0-2, FPL Load, View 3, Shroud Bottom Steady State Surface Temperatures (F)

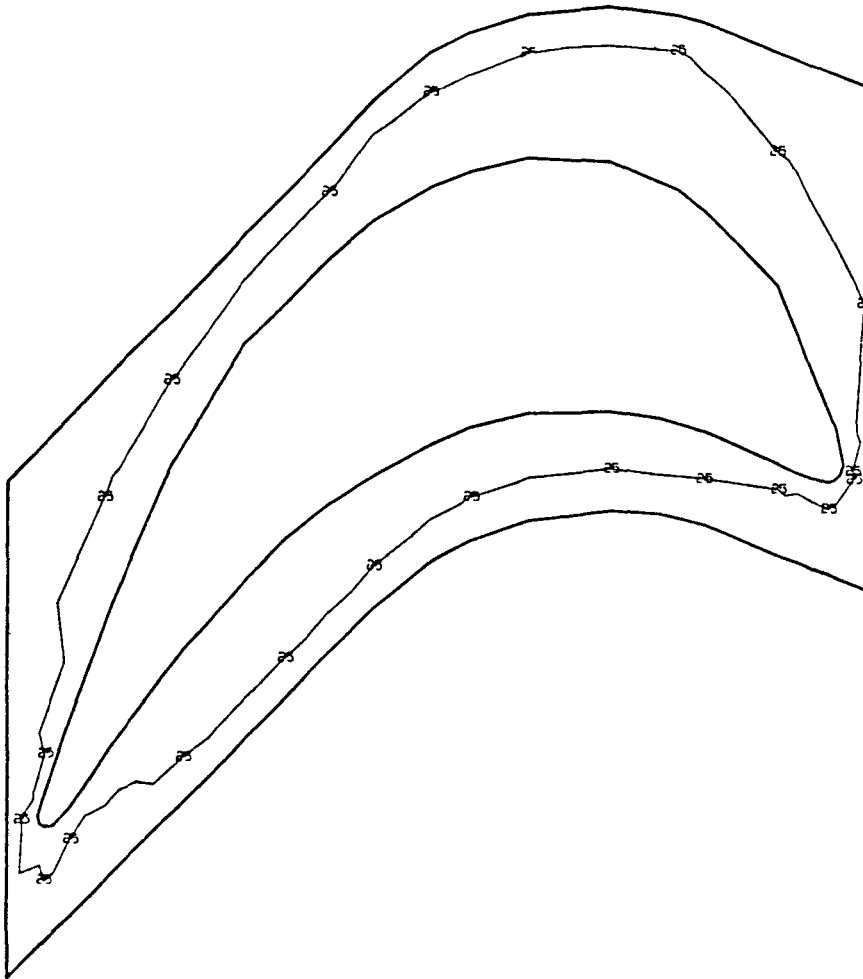

1	-3.000000E 02	14	3.500000E 02	27	1.000000E 03
2	-2.500000E 02	15	4.000000E 02	28	1.050000E 03
3	-2.000000E 02	16	4.500000E 02	29	1.100000E 03
4	-1.500000E 02	17	5.000000E 02	30	1.150000E 03
5	-1.000000E 02	18	5.500000E 02	31	1.200000E 03
6	-5.000000E 01	19	6.000000E 02	32	1.250000E 03
7	0.0	20	6.500000E 02	33	1.300000E 03
8	5.000000E 01	21	7.000000E 02	34	1.350000E 03
9	1.000000E 02	22	7.500000E 02	35	1.400000E 03
10	1.500000E 02	23	8.000000E 02	36	1.450000E 03
11	2.000000E 02	24	8.500000E 02	37	1.500000E 03
12	2.500000E 02	25	9.000000E 02	38	1.550000E 03
13	3.000000E 02	26	9.500000E 02	39	1.600000E 03

Fig. 2.5-7 Model 0-2, FPL Load, View 3, Platform Top Steady State Surface Temperatures (F)

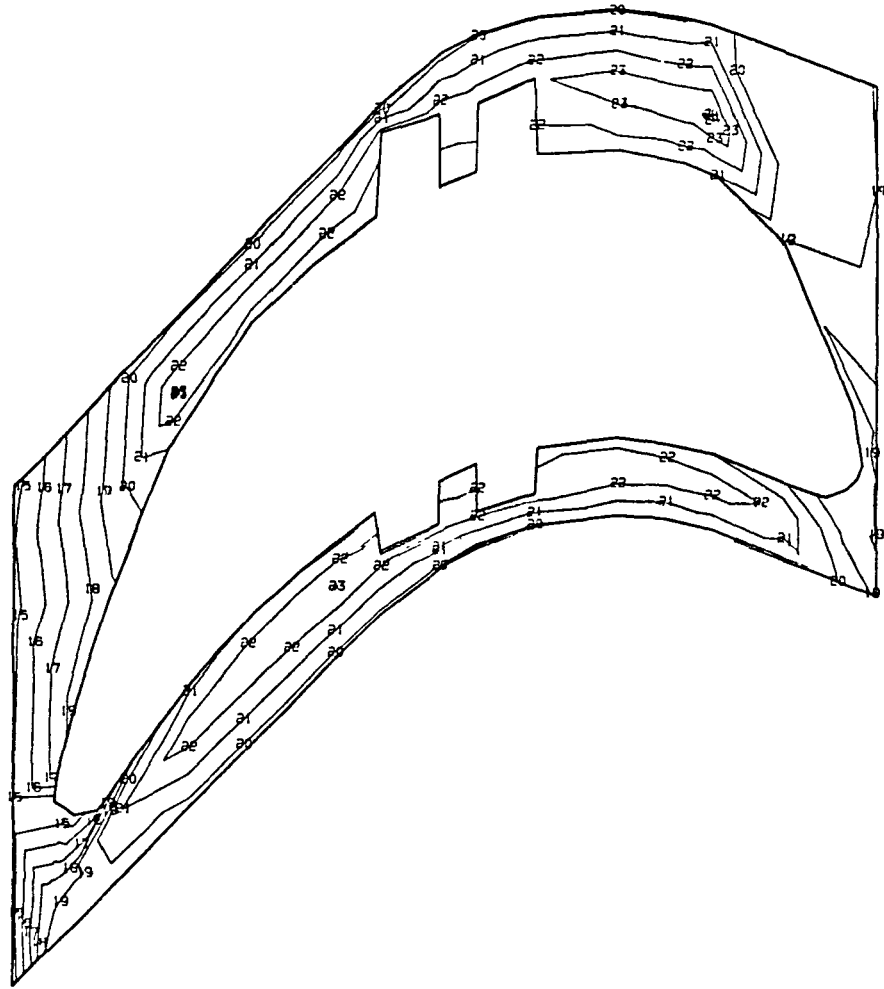

1	-3.000000E 02	14	3.500000E 02	27	1.000000E 03
2	-2.500000E 02	15	4.000000E 02	28	1.050000E 03
3	-2.000000E 02	16	4.500000E 02	29	1.100000E 03
4	-1.500000E 02	17	5.000000E 02	30	1.150000E 03
5	-1.000000E 02	18	5.500000E 02	31	1.200000E 03
6	-5.000000E 01	19	6.000000E 02	32	1.250000E 03
7	0.0	20	6.500000E 02	33	1.300000E 03
8	5.000000E 01	21	7.000000E 02	34	1.350000E 03
9	1.000000E 02	22	7.500000E 02	35	1.400000E 03
10	1.500000E 02	23	8.000000E 02	36	1.450000E 03
11	2.000000E 02	24	8.500000E 02	37	1.500000E 03
12	2.500000E 02	25	9.000000E 02	38	1.550000E 03
13	3.000000E 02	26	9.500000E 02	39	1.600000E 03

Fig. 2.5-8 Model 0-2, FPL Load, View 3, Platform Bottom Steady State Surface Temperatures (F)

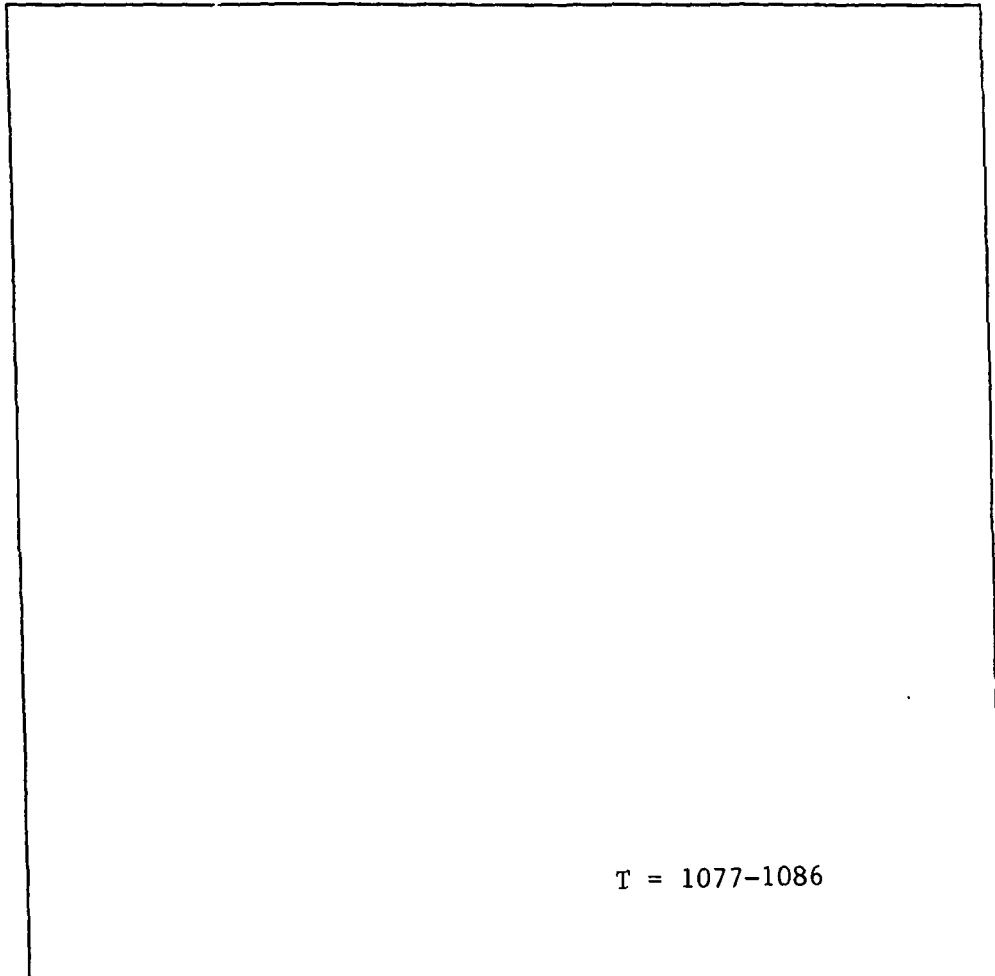

1	-3.000000E 02	14	3.500000E 02	27	1.000000E 03
2	-2.500000E 02	15	4.000000E 02	28	1.050000E 03
3	-2.000000E 02	16	4.500000E 02	29	1.100000E 03
4	-1.500000E 02	17	5.000000E 02	30	1.150000E 03
5	-1.000000E 02	18	5.500000E 02	31	1.200000E 03
6	-5.000000E 01	19	6.000000E 02	32	1.250000E 03
7	0.0	20	6.500000E 02	33	1.300000E 03
8	5.000000E 01	21	7.000000E 02	34	1.350000E 03
9	1.000000E 02	22	7.500000E 02	35	1.400000E 03
10	1.500000E 02	23	8.000000E 02	36	1.450000E 03
11	2.000000E 02	24	8.500000E 02	37	1.500000E 03
12	2.500000E 02	25	9.000000E 02	38	1.550000E 03
13	3.000000E 02	26	9.500000E 02	39	1.600000E 03

Fig. 2.5-9 Model 0-2, 115% Load, View 1, Airfoil Pressure Side Steady State Surface Temperatures (F)

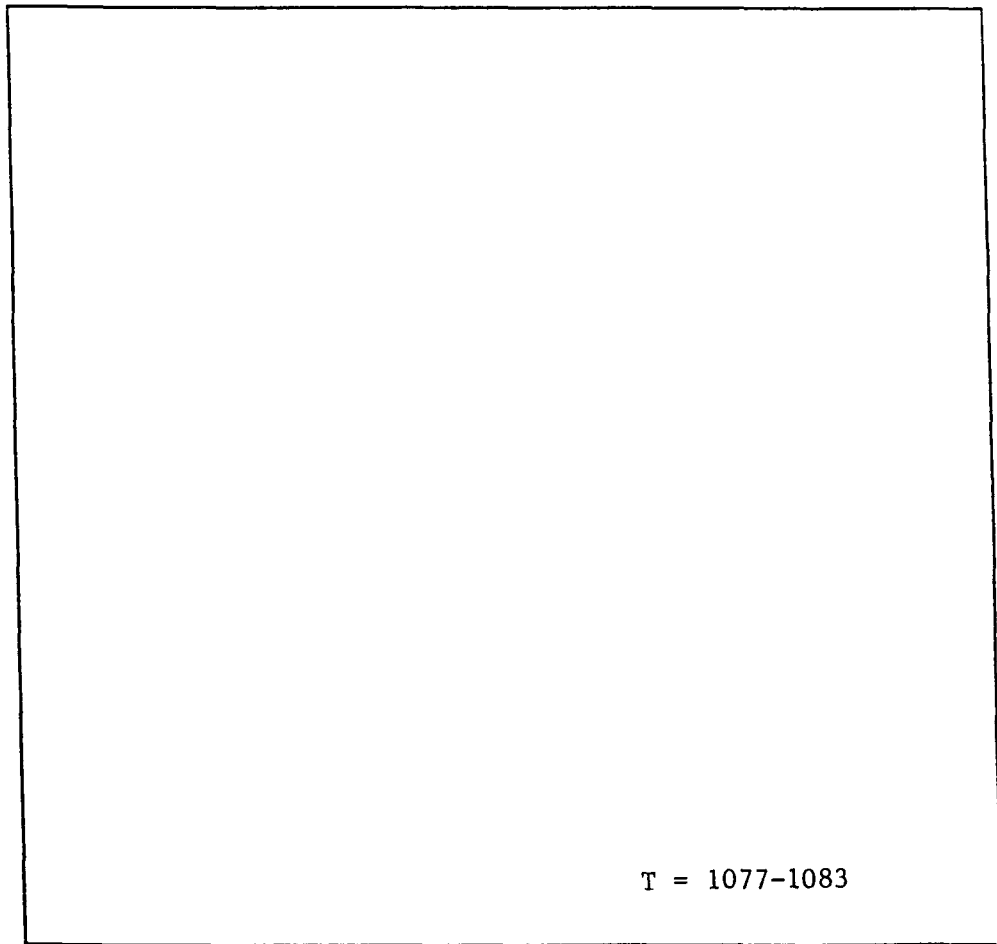

1	-3.000000E 02	14	3.500000E 02	27	1.000000E 03
2	-2.500000E 02	15	4.000000E 02	28	1.050000E 03
3	-2.000000E 02	16	4.500000E 02	29	1.100000E 03
4	-1.500000E 02	17	5.000000E 02	30	1.150000E 03
5	-1.000000E 02	18	5.500000E 02	31	1.200000E 03
6	-5.000000E 01	19	6.000000E 02	32	1.250000E 03
7	0.0	20	6.500000E 02	33	1.300000E 03
8	5.000000E 01	21	7.000000E 02	34	1.350000E 03
9	1.000000E 02	22	7.500000E 02	35	1.400000E 03
10	1.500000E 02	23	8.000000E 02	36	1.450000E 03
11	2.000000E 02	24	8.500000E 02	37	1.500000E 03
12	2.500000E 02	25	9.000000E 02	38	1.550000E 03
13	3.000000E 02	26	9.500000E 02	39	1.600000E 03

Fig. 2.5-10 Model 0-2, 115% Load, View 1, Airfoil Suction Side Steady State Surface Temperatures (F)

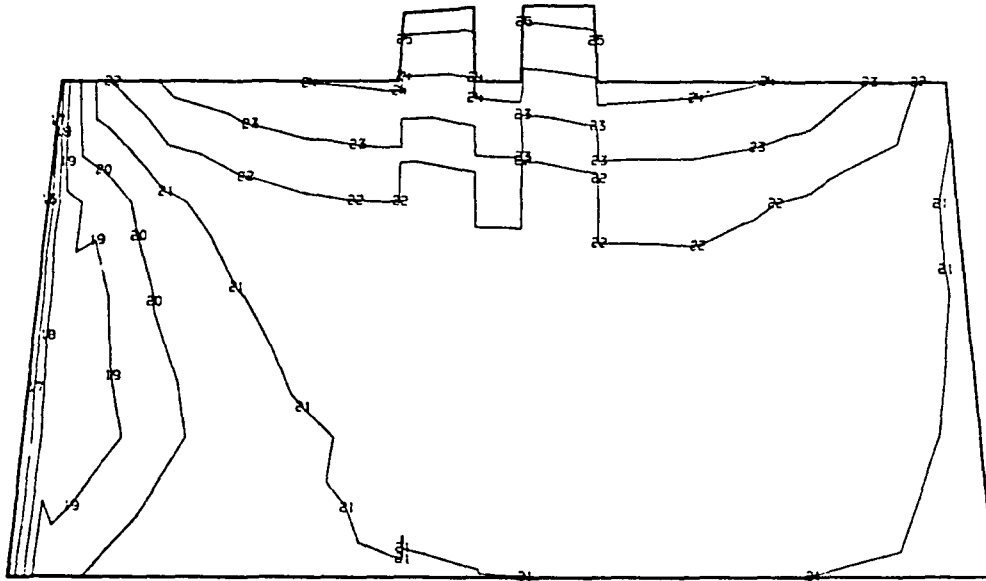

1	-3.000000E 02	14	3.500000E 02	27	1.000000E 03
2	-2.500000E 02	15	4.000000E 02	28	1.050000E 03
3	-2.000000E 02	16	4.500000E 02	29	1.100000E 03
4	-1.500000E 02	17	5.000000E 02	30	1.150000E 03
5	-1.000000E 02	18	5.500000E 02	31	1.200000E 03
6	-5.000000E 01	19	6.000000E 02	32	1.250000E 03
7	0.0	20	6.500000E 02	33	1.300000E 03
8	5.000000E 01	21	7.000000E 02	34	1.350000E 03
9	1.000000E 02	22	7.500000E 02	35	1.400000E 03
10	1.500000E 02	23	8.000000E 02	36	1.450000E 03
11	2.000000E 02	24	8.500000E 02	37	1.500000E 03
12	2.500000E 02	25	9.000000E 02	38	1.550000E 03
13	3.000000E 02	26	9.500000E 02	39	1.600000E 03

Fig. 2.5-11 Model 0-2, 115% Load, View 2, Shank Pressure Side Steady State Surface Temperatures (F)

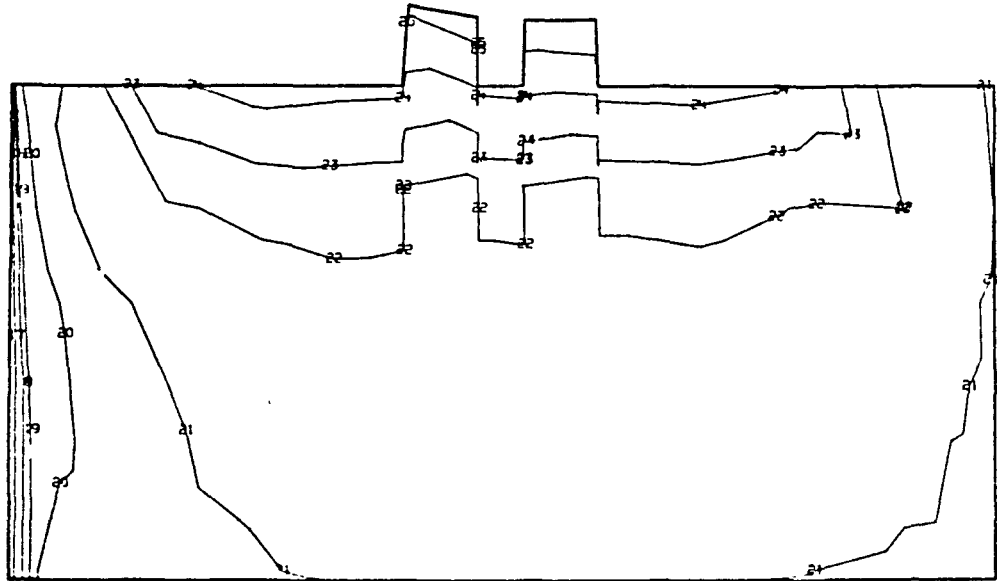

1	-3.000000E 02	14	3.500000E 02	27	1.000000E 03
2	-2.500000E 02	15	4.000000E 02	28	1.050000E 03
3	-2.000000E 02	16	4.500000E 02	29	1.100000E 03
4	-1.500000E 02	17	5.000000E 02	30	1.150000E 03
5	-1.000000E 02	18	5.500000E 02	31	1.200000E 03
6	-5.000000E 01	19	6.000000E 02	32	1.250000E 03
7	0.0	20	6.500000E 02	33	1.300000E 03
8	5.000000E 01	21	7.000000E 02	34	1.350000E 03
9	1.000000E 02	22	7.500000E 02	35	1.400000E 03
10	1.500000E 02	23	8.000000E 02	36	1.450000E 03
11	2.000000E 02	24	8.500000E 02	37	1.500000E 03
12	2.500000E 02	25	9.000000E 02	38	1.550000E 03
13	3.000000E 02	26	9.500000E 02	39	1.600000E 03

Fig. 2.5-12 Model 0-2, 115% Load, View 2, Shank Suction Side Steady State Surface Temperatures (F)

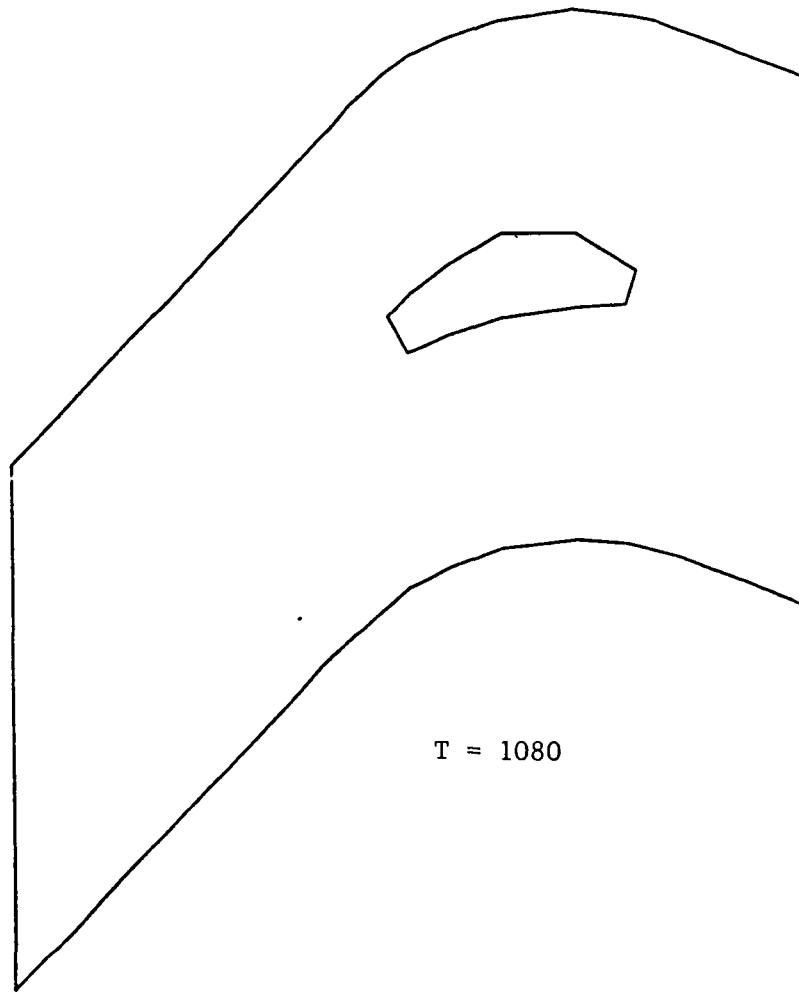

1	-3.000000E 02	14	3.500000E 02	27	1.000000E 03
2	-2.500000E 02	15	4.000000E 02	28	1.050000E 03
3	-2.000000E 02	16	4.500000E 02	29	1.100000E 03
4	-1.500000E 02	17	5.000000E 02	30	1.150000E 03
5	-1.000000E 02	18	5.500000E 02	31	1.200000E 03
6	-5.000000E 01	19	6.000000E 02	32	1.250000E 03
7	0.0	20	6.500000E 02	33	1.300000E 03
8	5.000000E 01	21	7.000000E 02	34	1.350000E 03
9	1.000000E 02	22	7.500000E 02	35	1.400000E 03
10	1.500000E 02	23	8.000000E 02	36	1.450000E 03
11	2.000000E 02	24	8.500000E 02	37	1.500000E 03
12	2.500000E 02	25	9.000000E 02	38	1.550000E 03
13	3.000000E 02	26	9.500000E 02	39	1.600000E 03

Fig. 2.5-13 Model 0-2, 115% Load, View 3, Shroud Top Steady State Surface Temperatures (F)

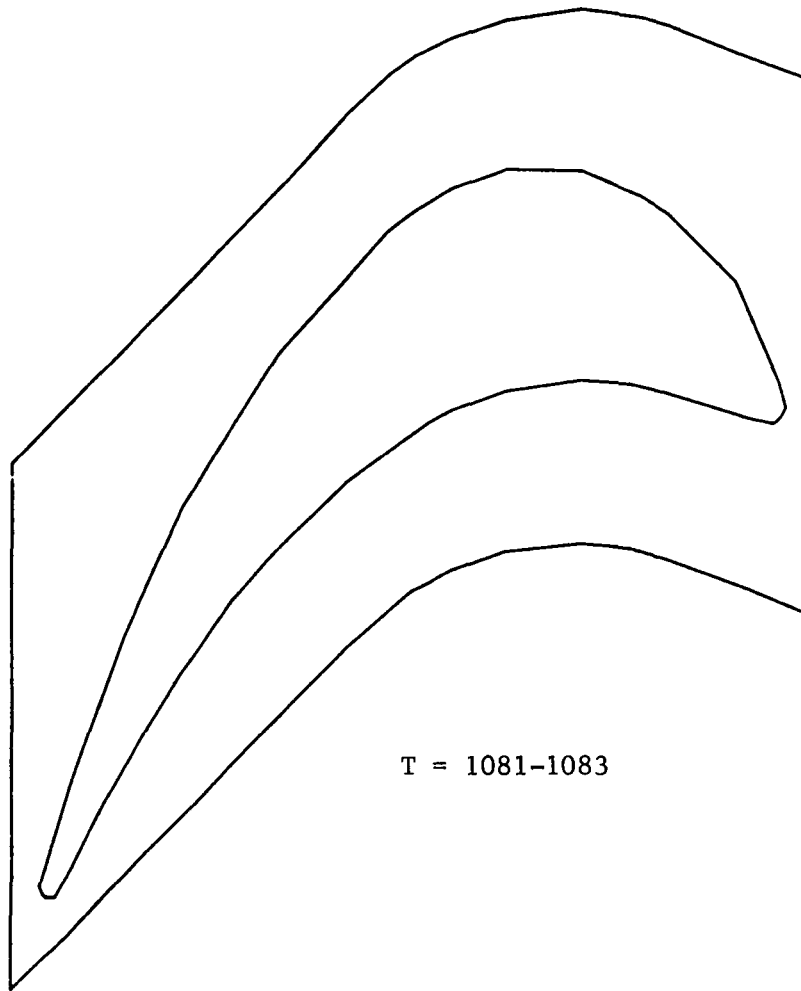

T = 1081-1083

1	-3.000000E 02	14	3.500000E 02	27	1.000000E 03
2	-2.500000E 02	15	4.000000E 02	28	1.050000E 03
3	-2.000000E 02	16	4.500000E 02	29	1.100000E 03
4	-1.500000E 02	17	5.000000E 02	30	1.150000E 03
5	-1.000000E 02	18	5.500000E 02	31	1.200000E 03
6	-5.000000E 01	19	6.000000E 02	32	1.250000E 03
7	0.0	20	6.500000E 02	33	1.300000E 03
8	5.000000E 01	21	7.000000E 02	34	1.350000E 03
9	1.000000E 02	22	7.500000E 02	35	1.400000E 03
10	1.500000E 02	23	8.000000E 02	36	1.450000E 03
11	2.000000E 02	24	8.500000E 02	37	1.500000E 03
12	2.500000E 02	25	9.000000E 02	38	1.550000E 03
13	3.000000E 02	26	9.500000E 02	39	1.600000E 03

Fig. 2.5-14 Model 0-2, 115% Load, View 3, Shroud Bottom Steady State Surface Temperatures (F)

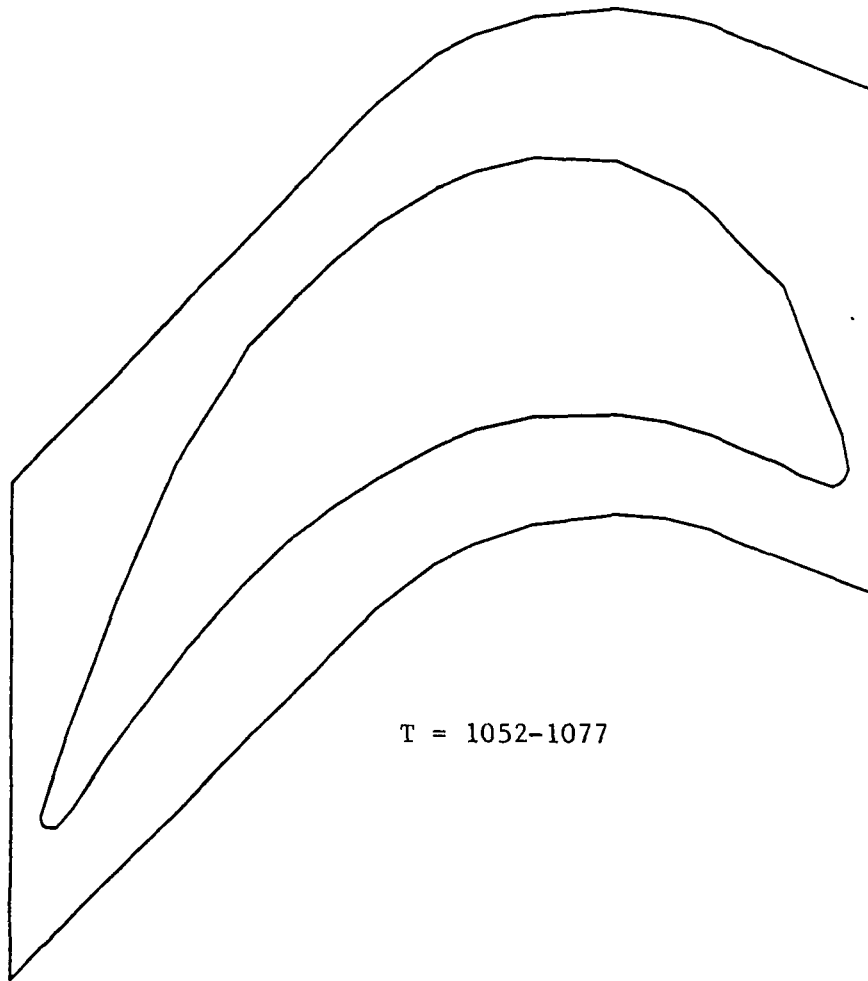

T = 1052-1077

1	-3.000000E 02	14	3.500000E 02	27	1.000000E 03
2	-2.500000E 02	15	4.000000E 02	28	1.050000E 03
3	-2.000000E 02	16	4.500000E 02	29	1.100000E 03
4	-1.500000E 02	17	5.000000E 02	30	1.150000E 03
5	-1.000000E 02	18	5.500000E 02	31	1.200000E 03
6	-5.000000E 01	19	6.000000E 02	32	1.250000E 03
7	0.0	20	6.500000E 02	33	1.300000E 03
8	5.000000E 01	21	7.000000E 02	34	1.350000E 03
9	1.000000E 02	22	7.500000E 02	35	1.400000E 03
10	1.500000E 02	23	8.000000E 02	36	1.450000E 03
11	2.000000E 02	24	8.500000E 02	37	1.500000E 03
12	2.500000E 02	25	9.000000E 02	38	1.550000E 03
13	3.000000E 02	26	9.500000E 02	39	1.600000E 03

Fig. 2.5-15 Model 0-2, 115% Load, View 3, Platform Top Steady State Surface Temperatures (F)

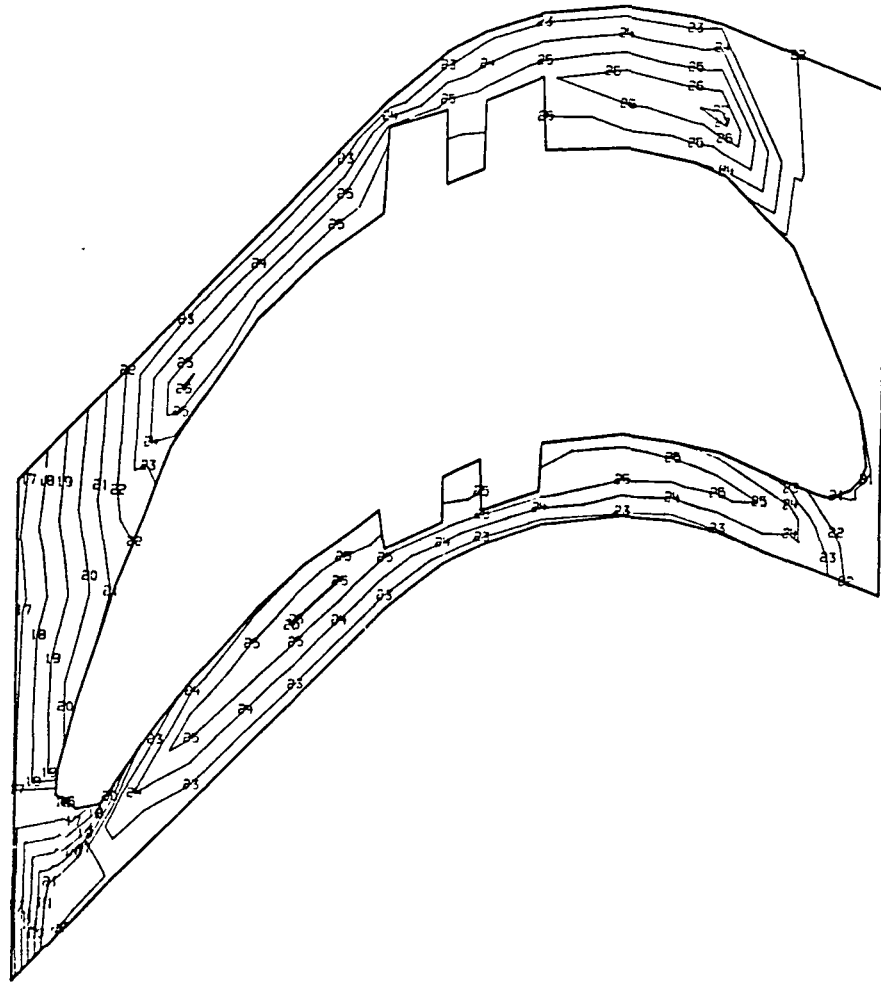

1	-3.000000E 02	14	3.500000E 02	27	1.000000E 03
2	-2.500000E 02	15	4.000000E 02	28	1.050000E 03
3	-2.000000E 02	16	4.500000E 02	29	1.100000E 03
4	-1.500000E 02	17	5.000000E 02	30	1.150000E 03
5	-1.000000E 02	18	5.500000E 02	31	1.200000E 03
6	-5.000000E 01	19	6.000000E 02	32	1.250000E 03
7	0.0	20	6.500000E 02	33	1.300000E 03
8	5.000000E 01	21	7.000000E 02	34	1.350000E 03
9	1.000000E 02	22	7.500000E 02	35	1.400000E 03
10	1.500000E 02	23	8.000000E 02	36	1.450000E 03
11	2.000000E 02	24	8.500000E 02	37	1.500000E 03
12	2.500000E 02	25	9.000000E 02	38	1.550000E 03
13	3.000000E 02	26	9.500000E 02	39	1.600000E 03

Fig. 2.5-16 Model 0-2, 115% Load, View 3, Platform Bottom Steady State Surface Temperatures (F)

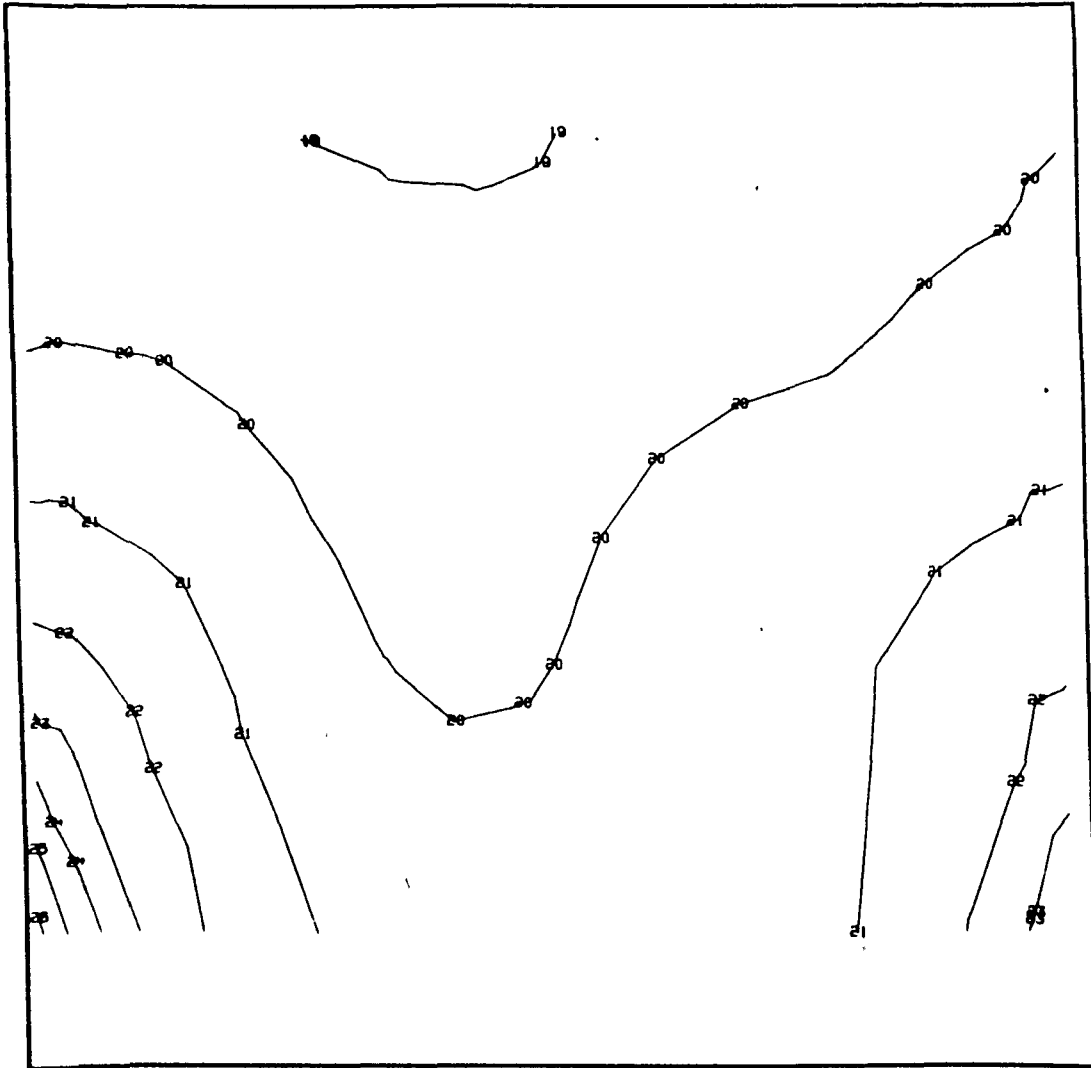

1	-1.500000E 05	12	-4.000000E 04	23	5.000000E 04
2	-1.400000E 05	13	-3.000000E 04	24	6.000000E 04
3	-1.300000E 05	14	-2.000000E 04	25	7.000000E 04
4	-1.200000E 05	15	-1.000000E 04	26	8.000000E 04
5	-1.100000E 05	16	-5.000000E 03	27	9.000000E 04
6	-1.000000E 05	17	0.0	28	1.000000E 05
7	-9.000000E 04	18	5.000000E 03	29	1.100000E 05
8	-8.000000E 04	19	1.000000E 04	30	1.200000E 05
9	-7.000000E 04	20	2.000000E 04	31	1.300000E 05
10	-6.000000E 04	21	3.000000E 04	32	1.400000E 05
11	-5.000000E 04	22	4.000000E 04	33	1.500000E 05

Fig. 2.5-17 Model 0-2, FPL Load, View 1, Airfoil Pressure Side
Major Principal Stress (psi)

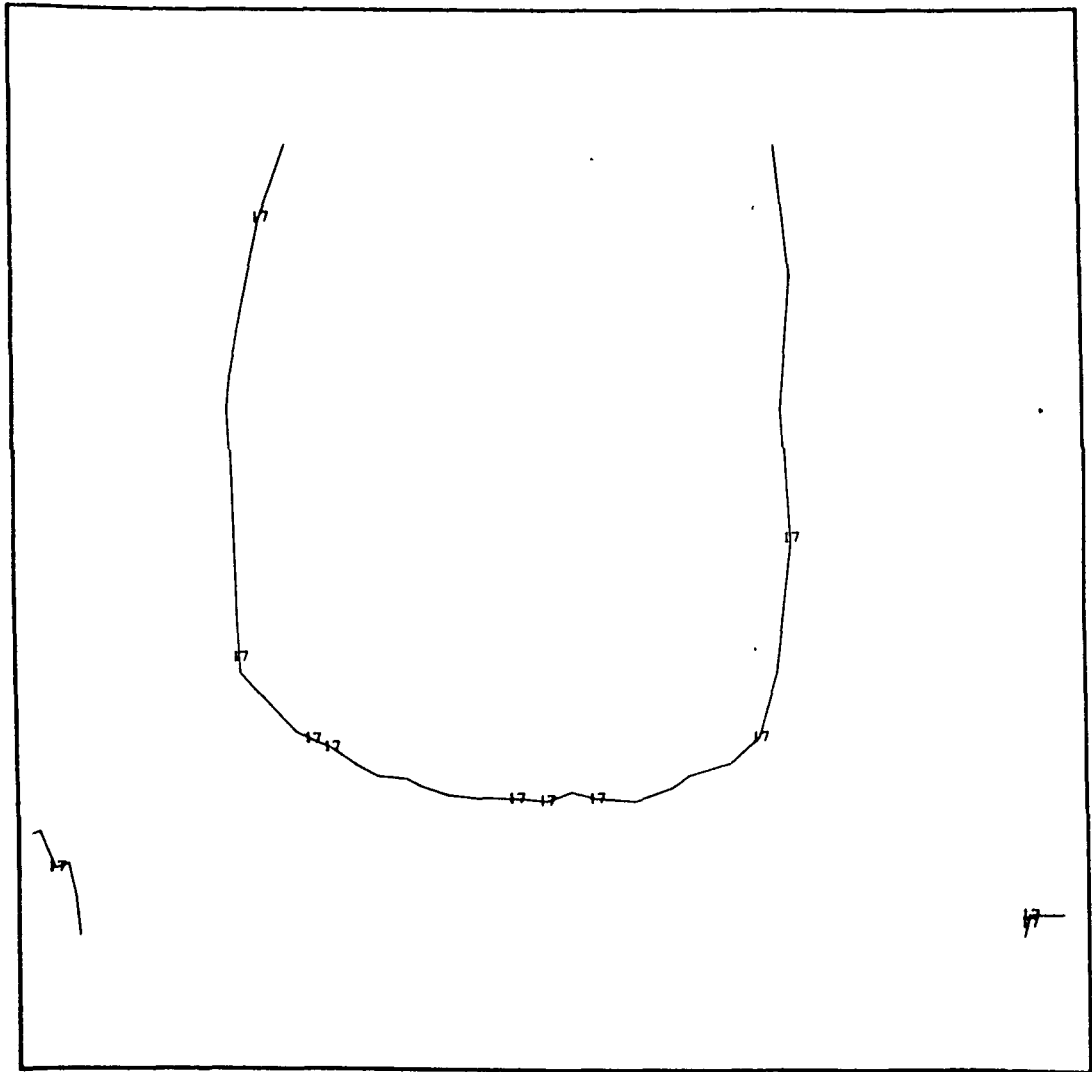

1	-1.500000E 05	12	-4.000000E 04	23	5.000000E 04
2	-1.400000E 05	13	-3.000000E 04	24	6.000000E 04
3	-1.300000E 05	14	-2.000000E 04	25	7.000000E 04
4	-1.200000E 05	15	-1.000000E 04	26	8.000000E 04
5	-1.100000E 05	16	-5.000000E 03	27	9.000000E 04
6	-1.000000E 05	17	0.0	28	1.000000E 05
7	-9.000000E 04	18	5.000000E 03	29	1.100000E 05
8	-8.000000E 04	19	1.000000E 04	30	1.200000E 05
9	-7.000000E 04	20	2.000000E 04	31	1.300000E 05
10	-6.000000E 04	21	3.000000E 04	32	1.400000E 05
11	-5.000000E 04	22	4.000000E 04	33	1.500000E 05

Fig. 2.5-18 Model 0-2, FPL Load, View 1, Airfoil Pressure Side
Minor Principal Stress (psi)

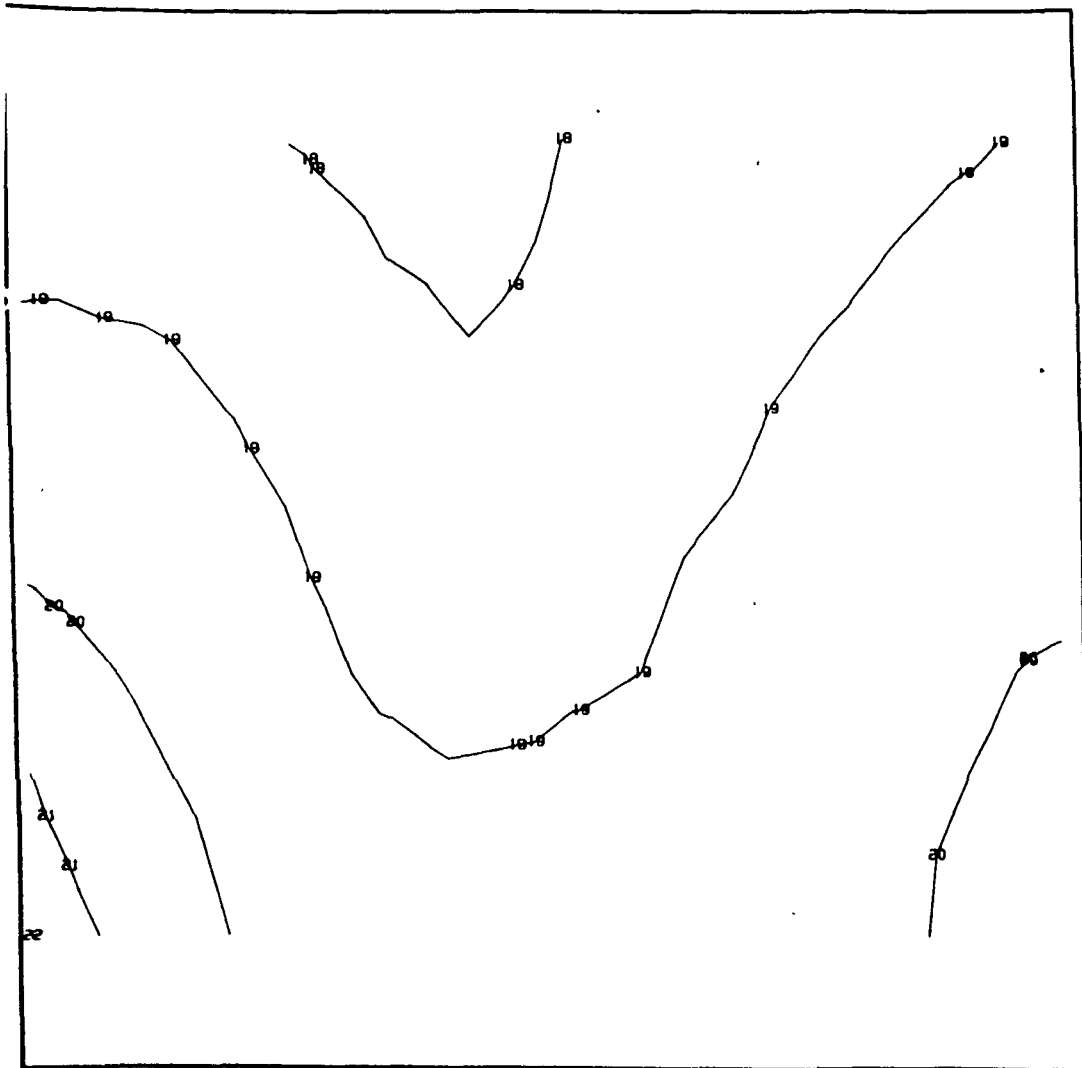

1	-1.500000E 05	12	-4.000000E 04	23	5.000000E 04
2	-1.400000E 05	13	-3.000000E 04	24	6.000000E 04
3	-1.300000E 05	14	-2.000000E 04	25	7.000000E 04
4	-1.200000E 05	15	-1.000000E 04	26	8.000000E 04
5	-1.100000E 05	16	-5.000000E 03	27	9.000000E 04
6	-1.000000E 05	17	0.0	28	1.000000E 05
7	-9.000000E 04	18	5.000000E 03	29	1.100000E 05
8	-8.000000E 04	19	1.000000E 04	30	1.200000E 05
9	-7.000000E 04	20	2.000000E 04	31	1.300000E 05
10	-6.000000E 04	21	3.000000E 04	32	1.400000E 05
11	-5.000000E 04	22	4.000000E 04	33	1.500000E 05

Fig. 2.5-19 Model 0-2, FPL Load, View 1, Airfoil Pressure Side
Maximum Principal Shear (psi)

2.5-19

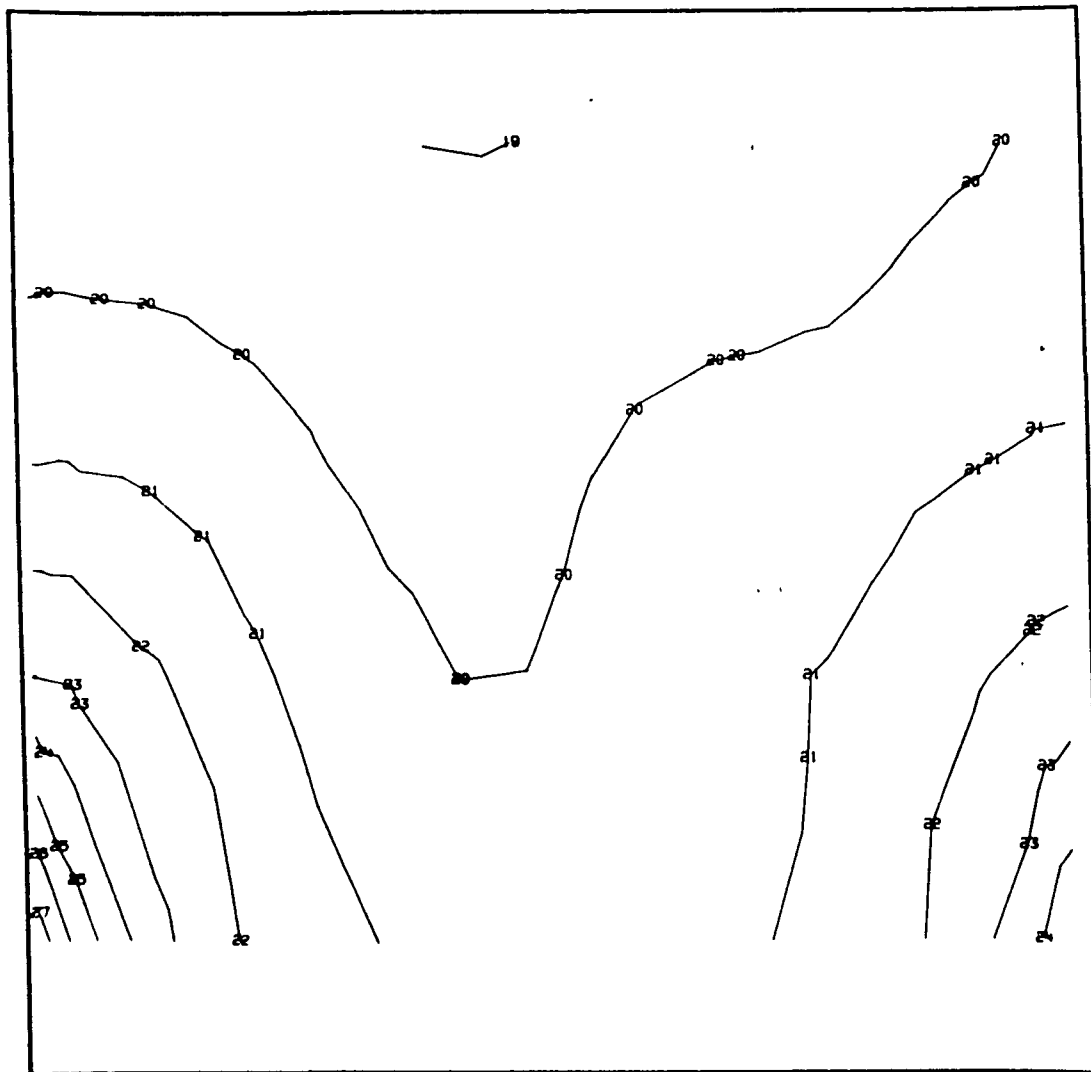

1	-1.500000E	05	12	-4.000000E	04	23	5.000000E	04
2	-1.400000E	05	13	-3.000000E	04	24	6.000000E	04
3	-1.300000E	05	14	-2.000000E	04	25	7.000000E	04
4	-1.200000E	05	15	-1.000000E	04	26	8.000000E	04
5	-1.100000E	05	16	-5.000000E	03	27	9.000000E	04
6	-1.000000E	05	17	0.0	28	1.000000E	05	
7	-9.000000E	04	18	5.000000E	03	29	1.100000E	05
8	-8.000000E	04	19	1.000000E	04	30	1.200000E	05
9	-7.000000E	04	20	2.000000E	04	31	1.300000E	05
10	-6.000000E	04	21	3.000000E	04	32	1.400000E	05
11	-5.000000E	04	22	4.000000E	04	33	1.500000E	05

Fig. 2.5-20 Model 0-2, 115% Load, View 1, Airfoil Pressure Side Major Principal Stress (psi)

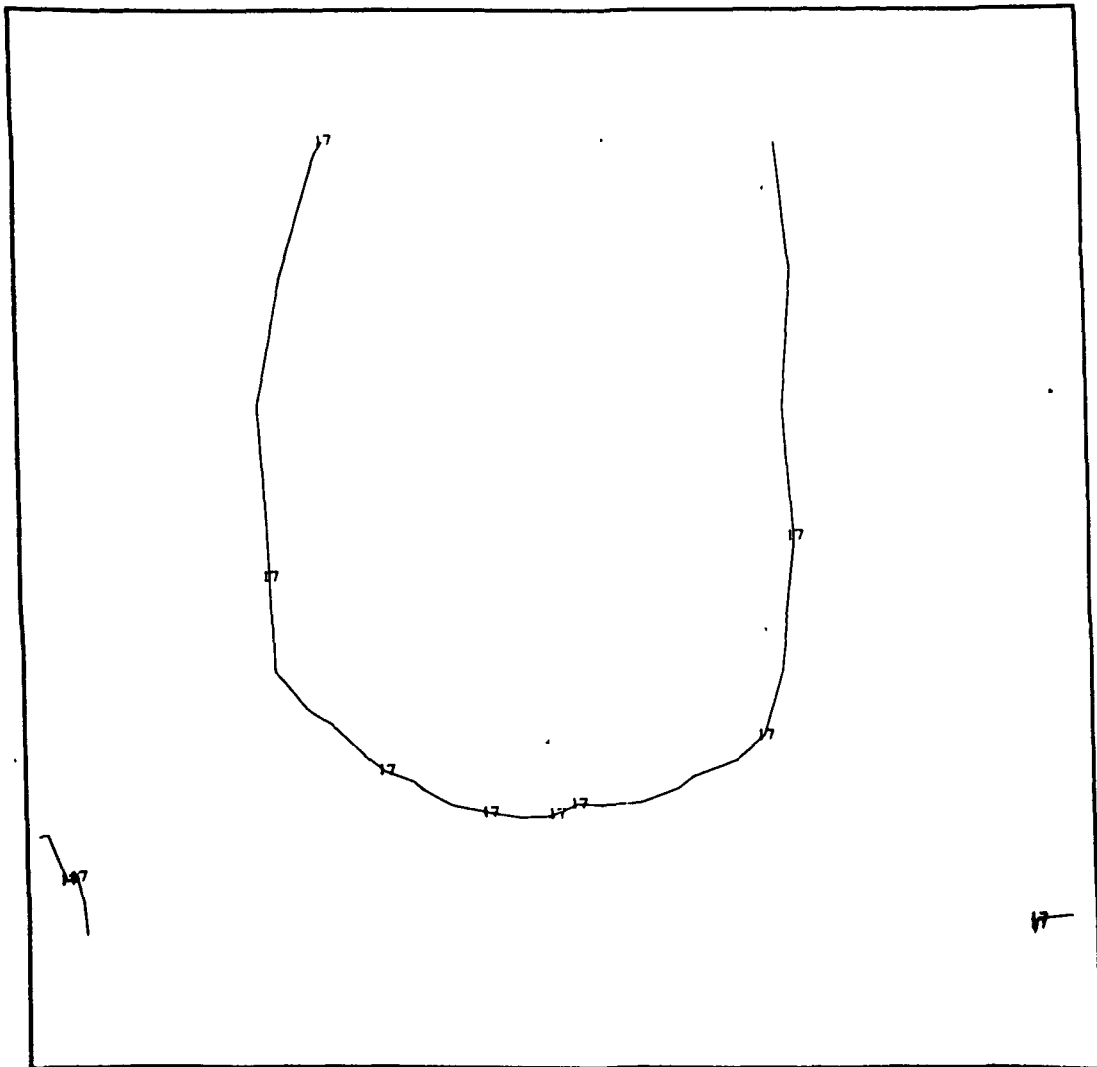

1	-1.500000E 05	12	-4.000000E 04	23	5.000000E 04
2	-1.400000E 05	13	-3.000000E 04	24	6.000000E 04
3	-1.300000E 05	14	-2.000000E 04	25	7.000000E 04
4	-1.200000E 05	15	-1.000000E 04	26	8.000000E 04
5	-1.100000E 05	16	-5.000000E 03	27	9.000000E 04
6	-1.000000E 05	17	0.0	28	1.000000E 05
7	-9.000000E 04	18	5.000000E 03	29	1.100000E 05
8	-8.000000E 04	19	1.000000E 04	30	1.200000E 05
9	-7.000000E 04	20	2.000000E 04	31	1.300000E 05
10	-6.000000E 04	21	3.000000E 04	32	1.400000E 05
11	-5.000000E 04	22	4.000000E 04	33	1.500000E 05

Fig. 2.5-21 Model 0-2, 115% Load, View 1, Airfoil Pressure Side
Minor Principal Stress (psi)

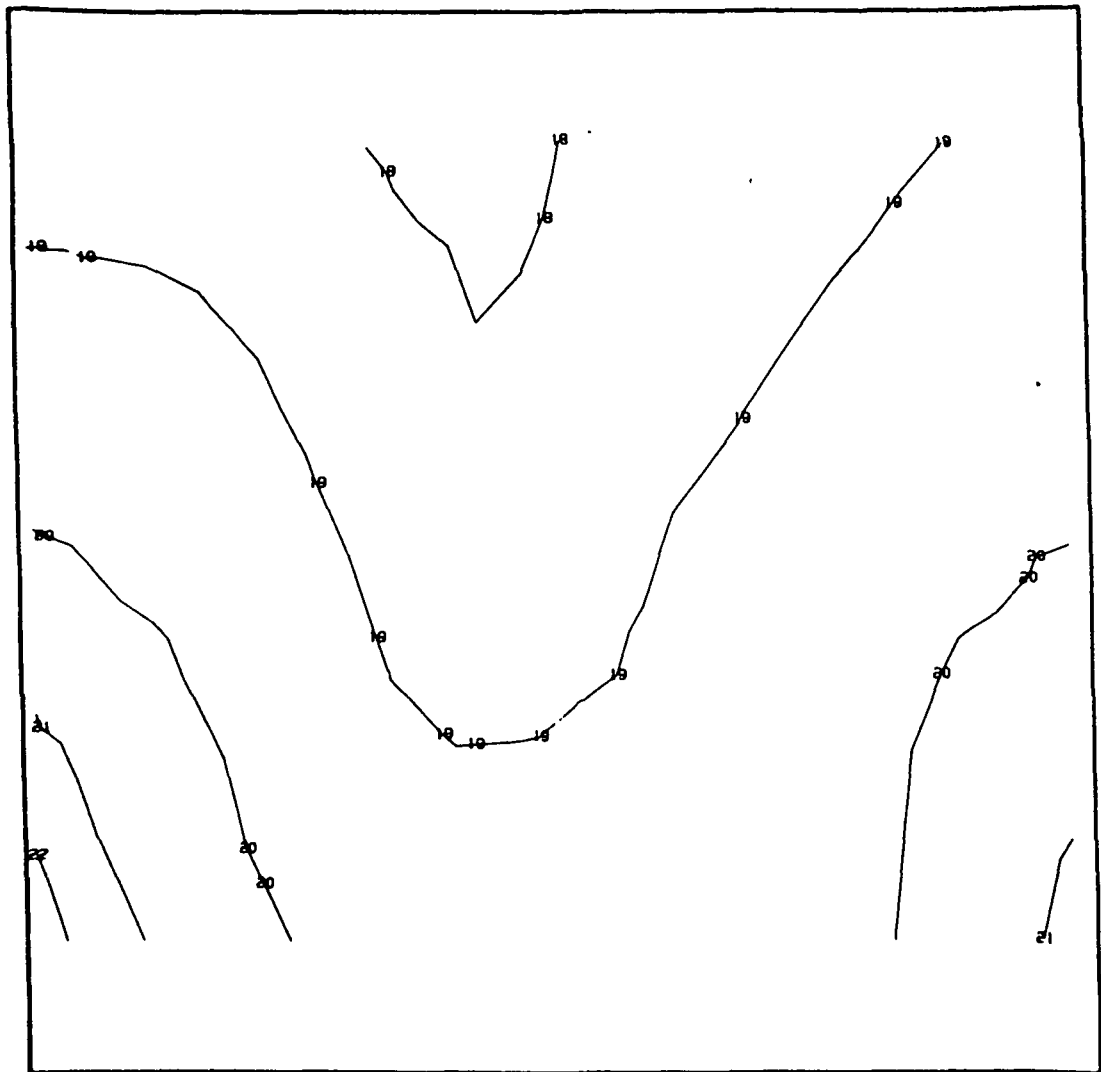

1	-1.500000E 05	12	-4.000000E 04	23	5.000000E 04
2	-1.400000E 05	13	-3.000000E 04	24	6.000000E 04
3	-1.300000E 05	14	-2.000000E 04	25	7.000000E 04
4	-1.200000E 05	15	-1.000000E 04	26	8.000000E 04
5	-1.100000E 05	16	-5.000000E 03	27	9.000000E 04
6	-1.000000E 05	17	0.0	28	1.000000E 05
7	-9.000000E 04	18	5.000000E 03	29	1.100000E 05
8	-8.000000E 04	19	1.000000E 04	30	1.200000E 05
9	-7.000000E 04	20	2.000000E 04	31	1.300000E 05
10	-6.000000E 04	21	3.000000E 04	32	1.400000E 05
11	-5.000000E 04	22	4.000000E 04	33	1.500000E 05

Fig. 2.5-22 Model 0-2, 115% Load, View 1, Airfoil Pressure Side Maximum Principal Shear (psi)

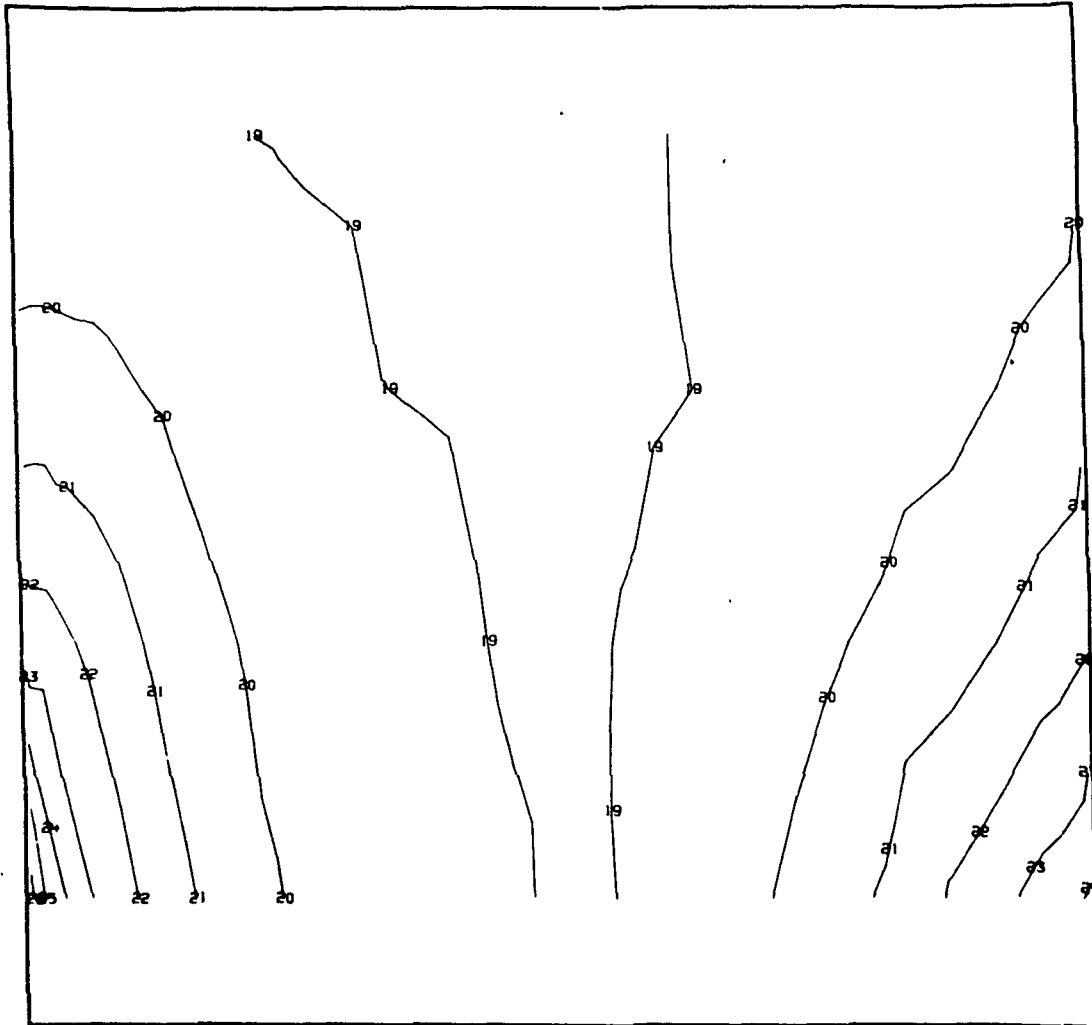

1	-1.500000E 05	12	-4.000000E 04	23	5.000000E 04
2	-1.400000E 05	13	-3.000000E 04	24	6.000000E 04
3	-1.300000E 05	14	-2.000000E 04	25	7.000000E 04
4	-1.200000E 05	15	-1.000000E 04	26	8.000000E 04
5	-1.100000E 05	16	-5.000000E 03	27	9.000000E 04
6	-1.000000E 05	17	0.0	28	1.000000E 05
7	-9.000000E 04	18	5.000000E 03	29	1.100000E 05
8	-8.000000E 04	19	1.000000E 04	30	1.200000E 05
9	-7.000000E 04	20	2.000000E 04	31	1.300000E 05
10	-6.000000E 04	21	3.000000E 04	32	1.400000E 05
11	-5.000000E 04	22	4.000000E 04	33	1.500000E 05

Fig. 2.5-23 Model 0-2, FPL Load, View 1, Airfoil Suction Side
Major Principal Stress (psi)

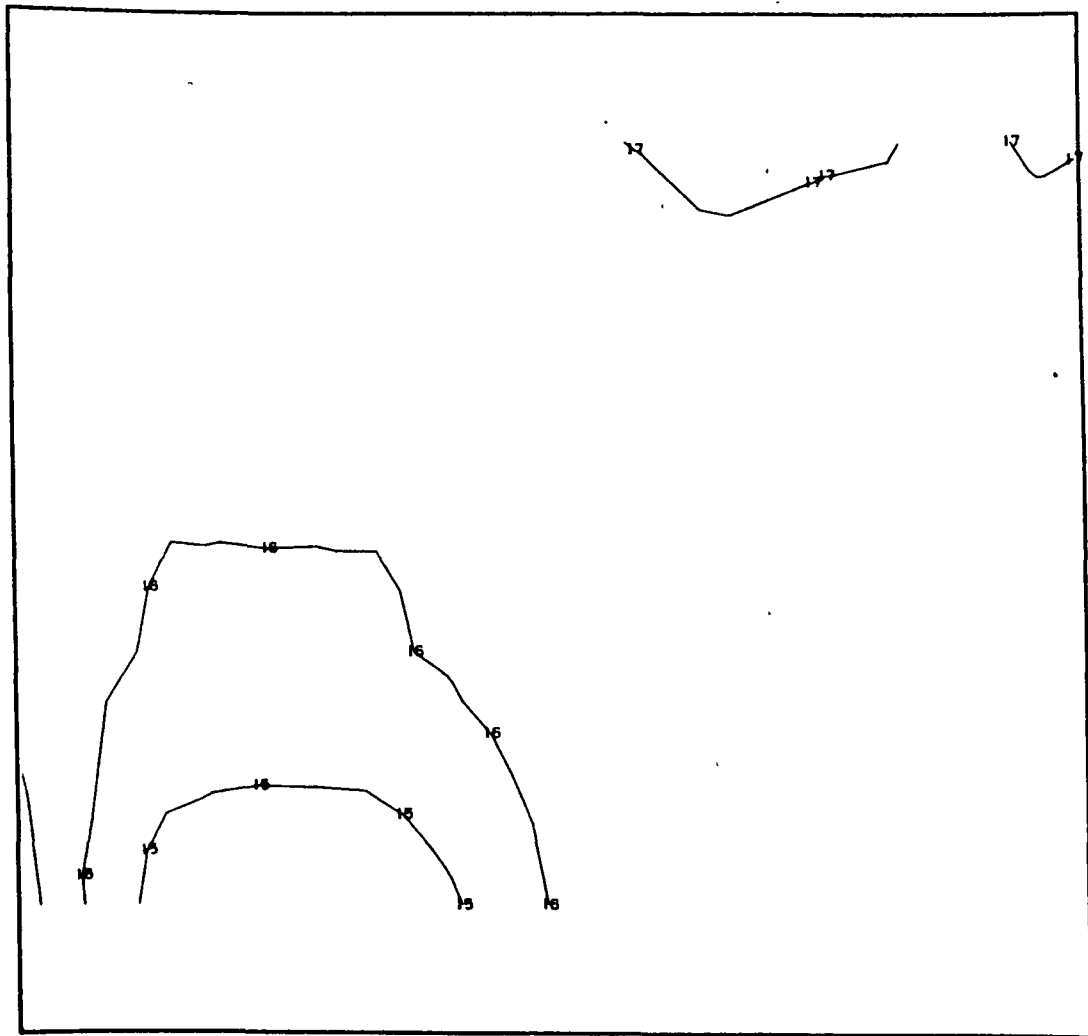

1	-1.500000E 05	05	12	-4.000000E 04	04	23	5.000000E 04	04
2	-1.400000E 05	05	13	-3.000000E 04	04	24	6.000000E 04	04
3	-1.300000E 05	05	14	-2.000000E 04	04	25	7.000000E 04	04
4	-1.200000E 05	05	15	-1.000000E 04	04	26	8.000000E 04	04
5	-1.100000E 05	05	16	-5.000000E 03	03	27	9.000000E 04	04
6	-1.000000E 05	05	17	0.0		28	1.000000E 05	05
7	-9.000000E 04	04	18	5.000000E 03	03	29	1.100000E 05	05
8	-8.000000E 04	04	19	1.000000E 04	04	30	1.200000E 05	05
9	-7.000000E 04	04	20	2.000000E 04	04	31	1.300000E 05	05
10	-6.000000E 04	04	21	3.000000E 04	04	32	1.400000E 05	05
11	-5.000000E 04	04	22	4.000000E 04	04	33	1.500000E 05	05

Fig. 2.5-24 Model 0-2, FPL Load, View 1, Airfoil Suction Side
Minor Principal Stress (psi)

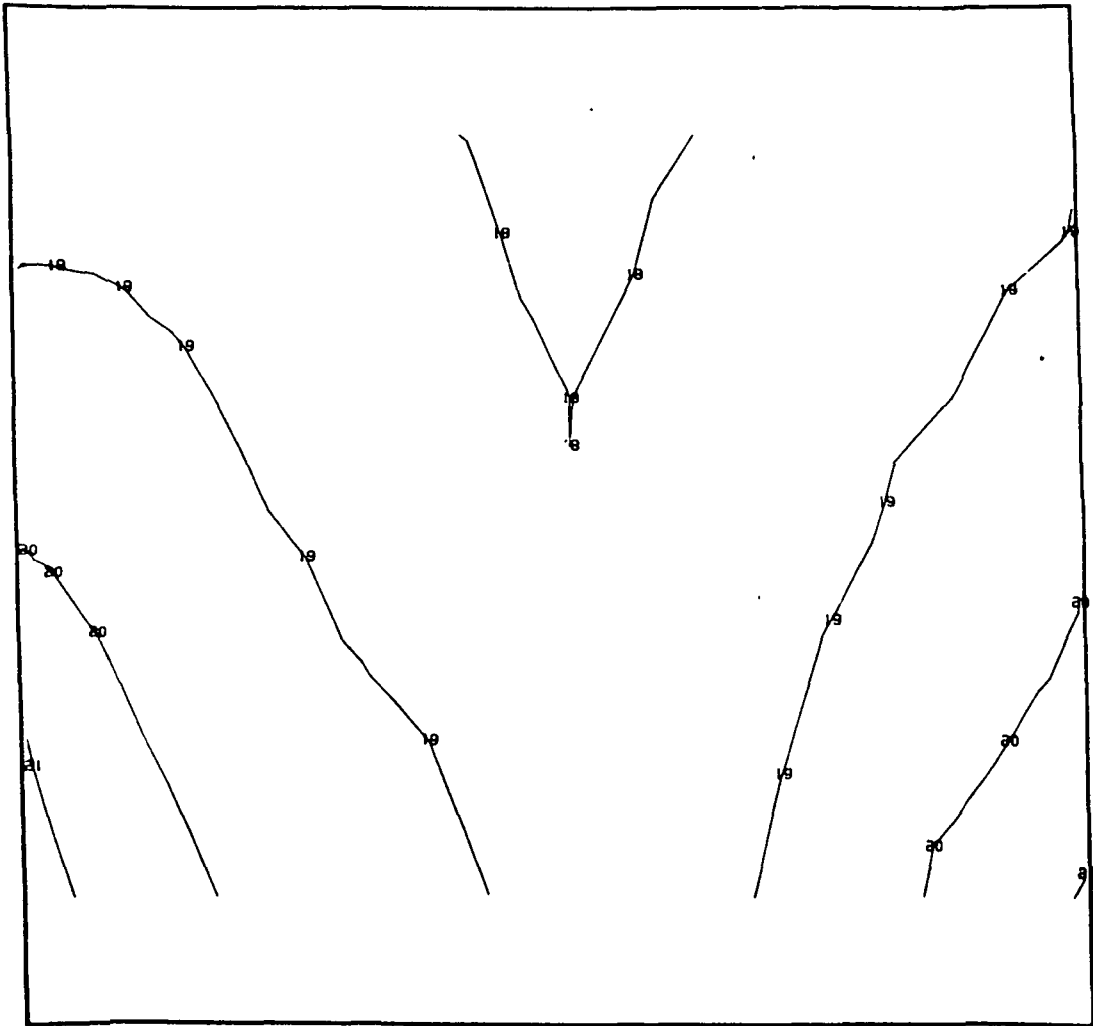

1	-1.500000E 05	05	12	-4.000000E 04	04	23	5.000000E 04	04
2	-1.400000E 05	05	13	-3.000000E 04	04	24	6.000000E 04	04
3	-1.300000E 05	05	14	-2.000000E 04	04	25	7.000000E 04	04
4	-1.200000E 05	05	15	-1.000000E 04	04	26	8.000000E 04	04
5	-1.100000E 05	05	16	-5.000000E 03	03	27	9.000000E 04	04
6	-1.000000E 05	05	17	0.0		28	1.000000E 05	05
7	-9.000000E 04	04	18	5.000000E 03	03	29	1.100000E 05	05
8	-8.000000E 04	04	19	1.000000E 04	04	30	1.200000E 05	05
9	-7.000000E 04	04	20	2.000000E 04	04	31	1.300000E 05	05
10	-6.000000E 04	04	21	3.000000E 04	04	32	1.400000E 05	05
11	-5.000000E 04	04	22	4.000000E 04	04	33	1.500000E 05	05

Fig. 2.5-25 Model 0-2, FPL Load, View 1, Airfoil Suction Side
Maximum Principal Shear (psi)

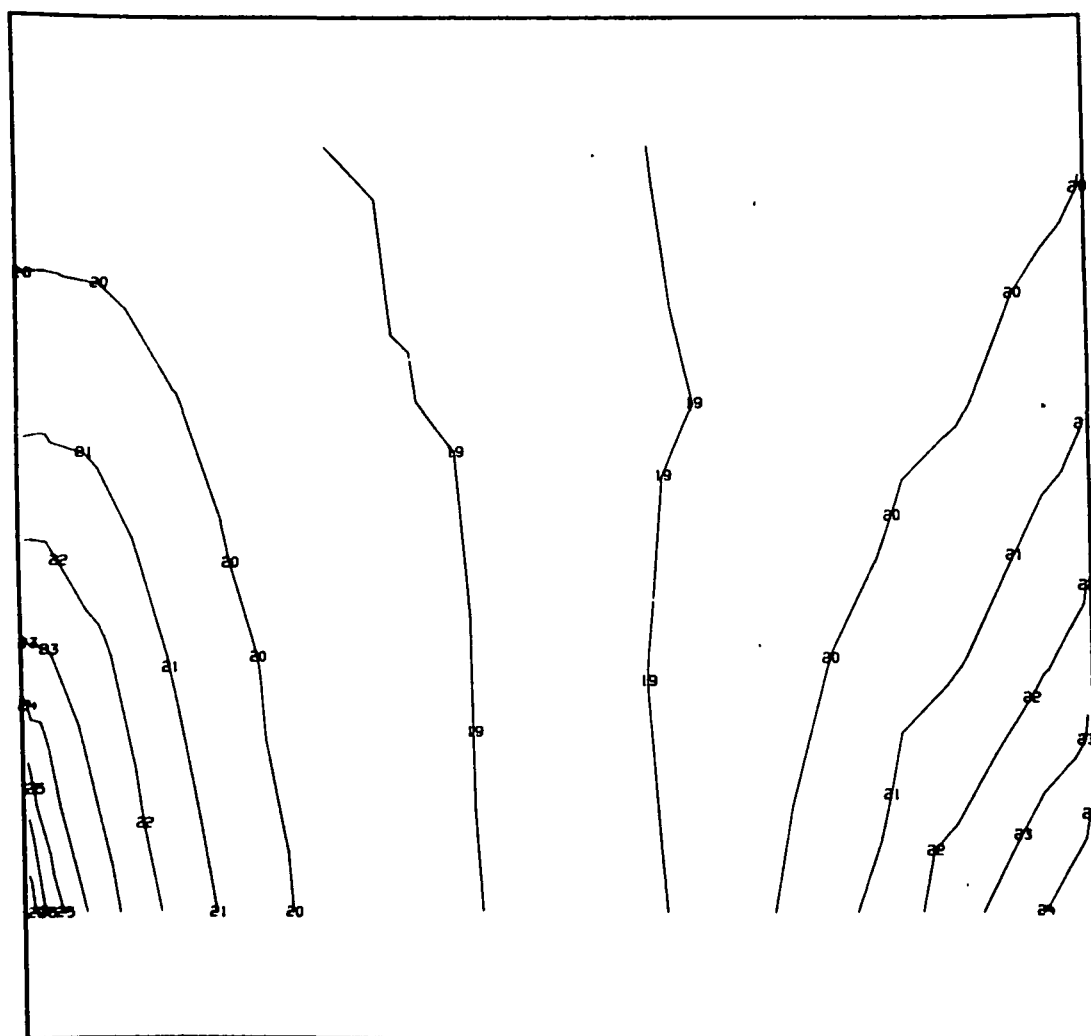

1	-1.500000E 05	05	12	-4.000000E 04	04	23	5.000000E 04	04
2	-1.400000E 05	05	13	-3.000000E 04	04	24	6.000000E 04	04
3	-1.300000E 05	05	14	-2.000000E 04	04	25	7.000000E 04	04
4	-1.200000E 05	05	15	-1.000000E 04	04	26	8.000000E 04	04
5	-1.100000E 05	05	16	-5.000000E 03	03	27	9.000000E 04	04
6	-1.000000E 05	05	17	0.0		28	1.000000E 05	05
7	-9.000000E 04	04	18	5.000000E 03	03	29	1.100000E 05	05
8	-8.000000E 04	04	19	1.000000E 04	04	30	1.200000E 05	05
9	-7.000000E 04	04	20	2.000000E 04	04	31	1.300000E 05	05
10	-6.000000E 04	04	21	3.000000E 04	04	32	1.400000E 05	05
11	-5.000000E 04	04	22	4.000000E 04	04	33	1.500000E 05	05

Fig. 2.5-26 Model 0-2, 115% Load, View 1, Airfoil Suction Side
Major Principal Stress (psi)

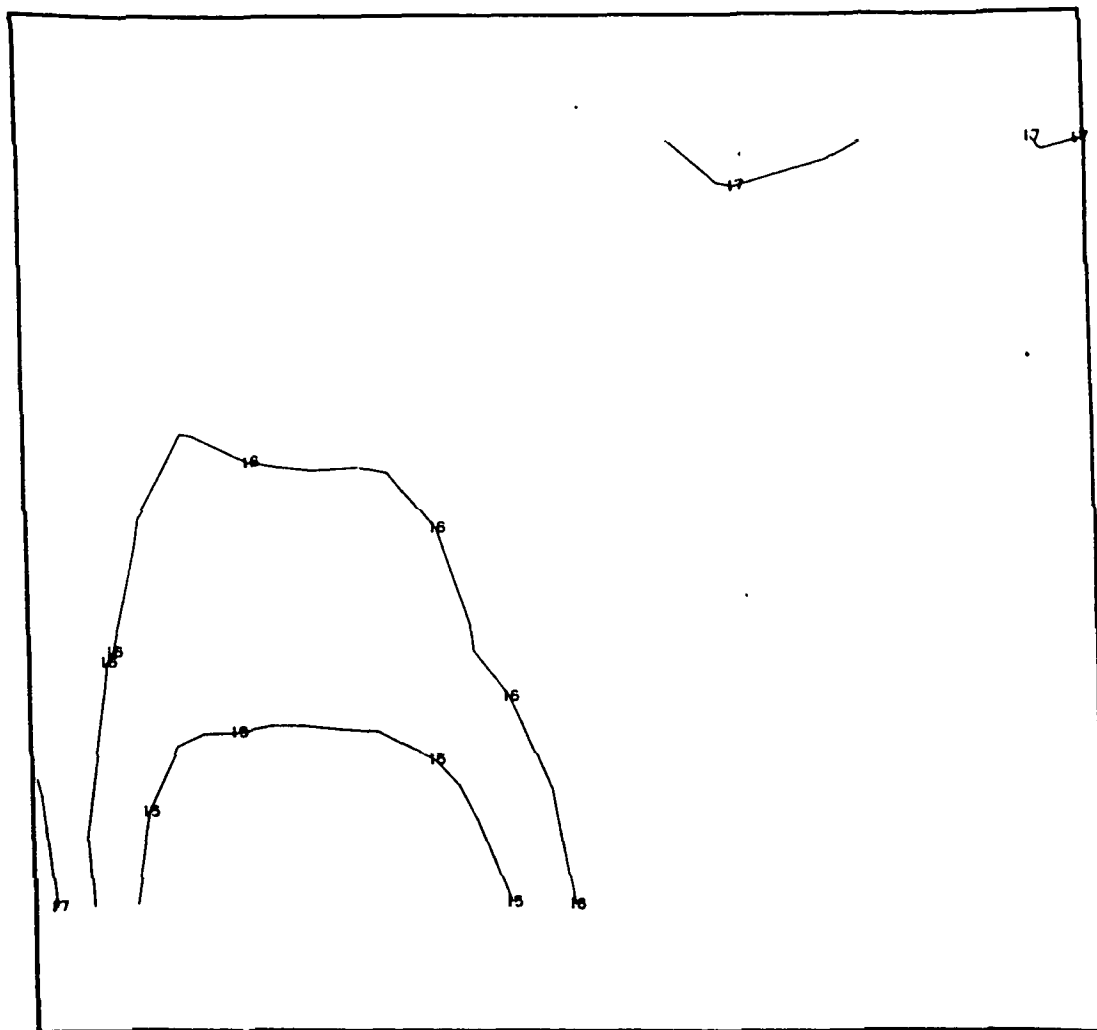

1	-1.500000E 05	12	-4.000000E 04	23	5.000000E 04
2	-1.400000E 05	13	-3.000000E 04	24	6.000000E 04
3	-1.300000E 05	14	-2.000000E 04	25	7.000000E 04
4	-1.200000E 05	15	-1.000000E 04	26	8.000000E 04
5	-1.100000E 05	16	-5.000000E 03	27	9.000000E 04
6	-1.000000E 05	17	0.0	28	1.000000E 05
7	-9.000000E 04	18	5.000000E 03	29	1.100000E 05
8	-8.000000E 04	19	1.000000E 04	30	1.200000E 05
9	-7.000000E 04	20	2.000000E 04	31	1.300000E 05
10	-6.000000E 04	21	3.000000E 04	32	1.400000E 05
11	-5.000000E 04	22	4.000000E 04	33	1.500000E 05

Fig. 2.5-27 Model 0-2, 115% Load, View 1, Airfoil Suction Side
Minor Principal Stress (psi)

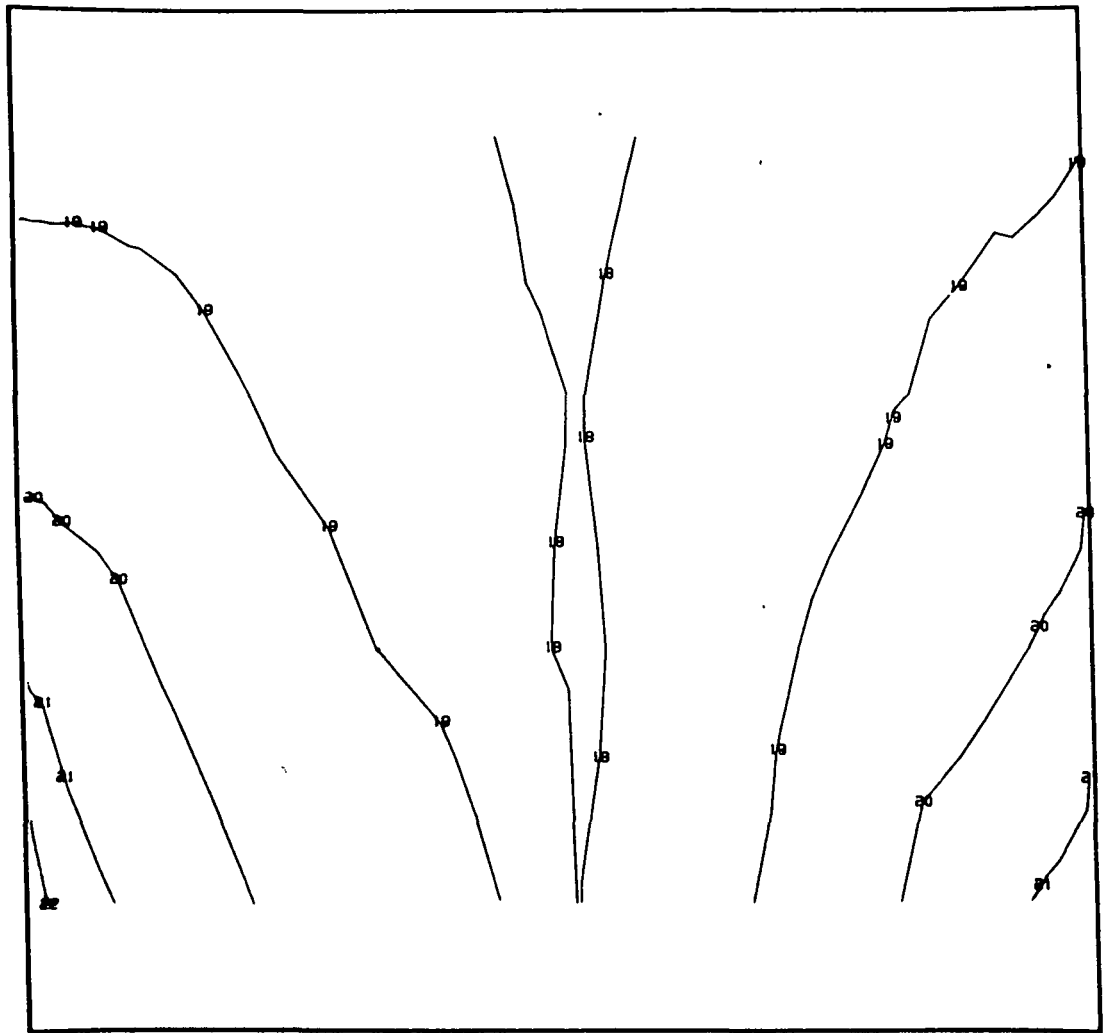

1	-1.500000E 05	12	-4.000000E 04	23	5.000000E 04
2	-1.400000E 05	13	-3.000000E 04	24	6.000000E 04
3	-1.300000E 05	14	-2.000000E 04	25	7.000000E 04
4	-1.200000E 05	15	-1.000000E 04	26	8.000000E 04
5	-1.100000E 05	16	-5.000000E 03	27	9.000000E 04
6	-1.000000E 05	17	0.0	28	1.000000E 05
7	-9.000000E 04	18	5.000000E 03	29	1.100000E 05
8	-8.000000E 04	19	1.000000E 04	30	1.200000E 05
9	-7.000000E 04	20	2.000000E 04	31	1.300000E 05
10	-6.000000E 04	21	3.000000E 04	32	1.400000E 05
11	-5.000000E 04	22	4.000000E 04	33	1.500000E 05

Fig. 2.5-28 Model O-2, 115% Load, View 1, Airfoil Suction Side
Maximum Principal Shear (psi)

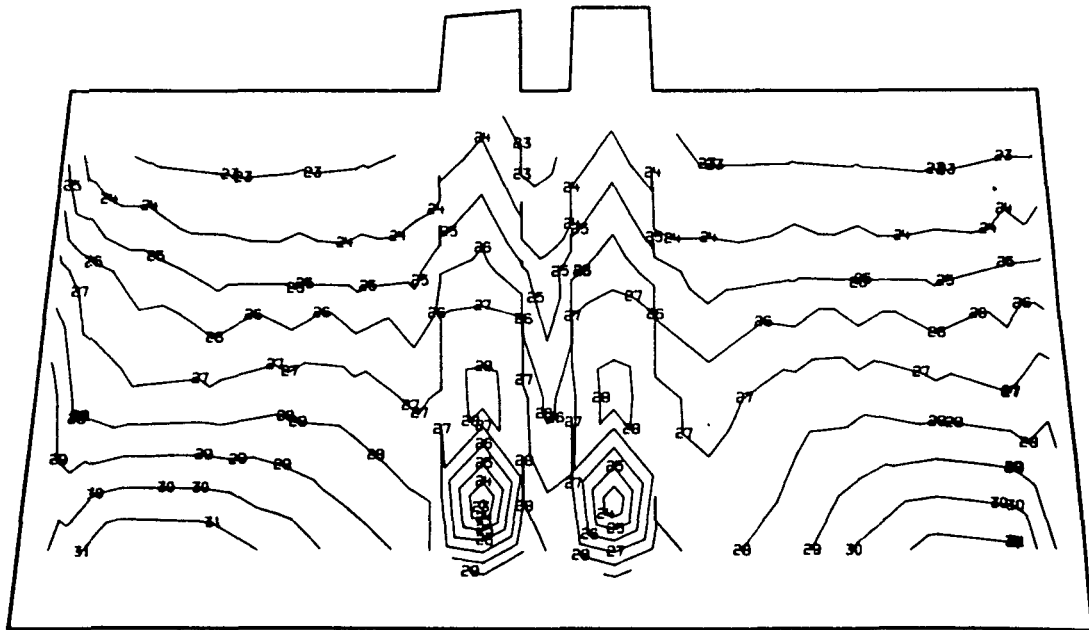

1	-1.500000E 05	12	-4.000000E 04	23	5.000000E 04
2	-1.400000E 05	13	-3.000000E 04	24	6.000000E 04
3	-1.300000E 05	14	-2.000000E 04	25	7.000000E 04
4	-1.200000E 05	15	-1.000000E 04	26	8.000000E 04
5	-1.100000E 05	16	-5.000000E 03	27	9.000000E 04
6	-1.000000E 05	17	0.0	28	1.000000E 05
7	-9.000000E 04	18	5.000000E 03	29	1.100000E 05
8	-8.000000E 04	19	1.000000E 04	30	1.200000E 05
9	-7.000000E 04	20	2.000000E 04	31	1.300000E 05
10	-6.000000E 04	21	3.000000E 04	32	1.400000E 05
11	-5.000000E 04	22	4.000000E 04	33	1.500000E 05

Fig. 2.5-29 Model 0-2, FPL Load, View 2, Shank Pressure Side
Major Principal Stress (psi)

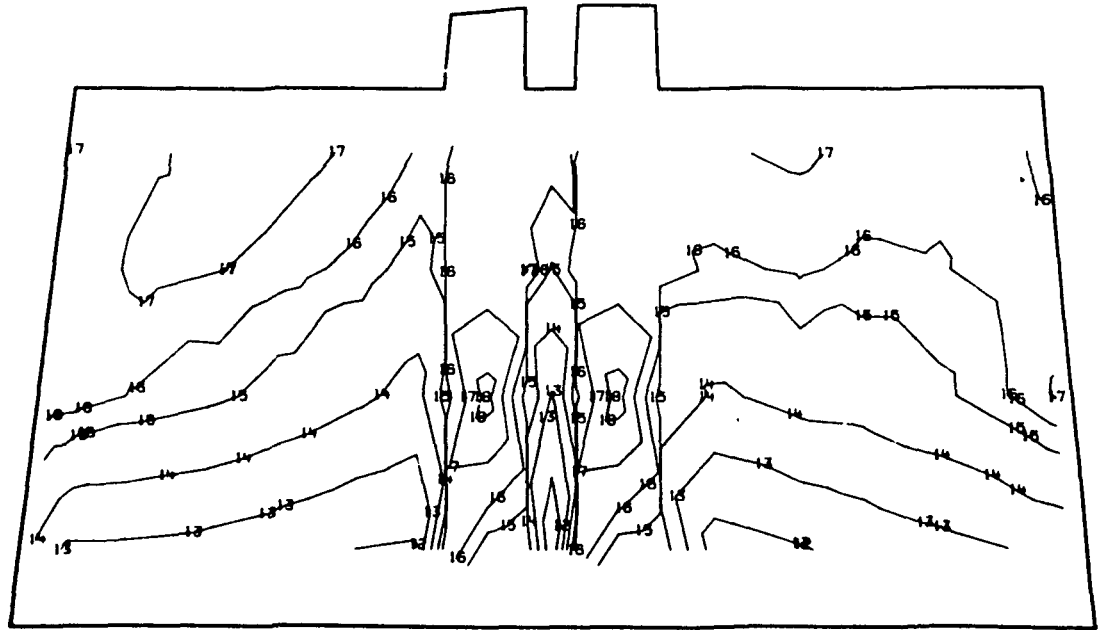

1	-1.500000E	05	12	-4.000000E	04	23	5.000000E	04
2	-1.400000E	05	13	-3.000000E	04	24	6.000000E	04
3	-1.300000E	05	14	-2.000000E	04	25	7.000000E	04
4	-1.200000E	05	15	-1.000000E	04	26	8.000000E	04
5	-1.100000E	05	16	-5.000000E	03	27	9.000000E	04
6	-1.000000E	05	17	0.0		28	1.000000E	05
7	-9.000000E	04	18	5.000000E	03	29	1.100000E	05
8	-8.000000E	04	19	1.000000E	04	30	1.200000E	05
9	-7.000000E	04	20	2.000000E	04	31	1.300000E	05
10	-6.000000E	04	21	3.000000E	04	32	1.400000E	05
11	-5.000000E	04	22	4.000000E	04	33	1.500000E	05

Fig. 2.5-30 Model 0-2, FPL Load, View 2, Shank Pressure Side
Minor Principal Stress (psi)

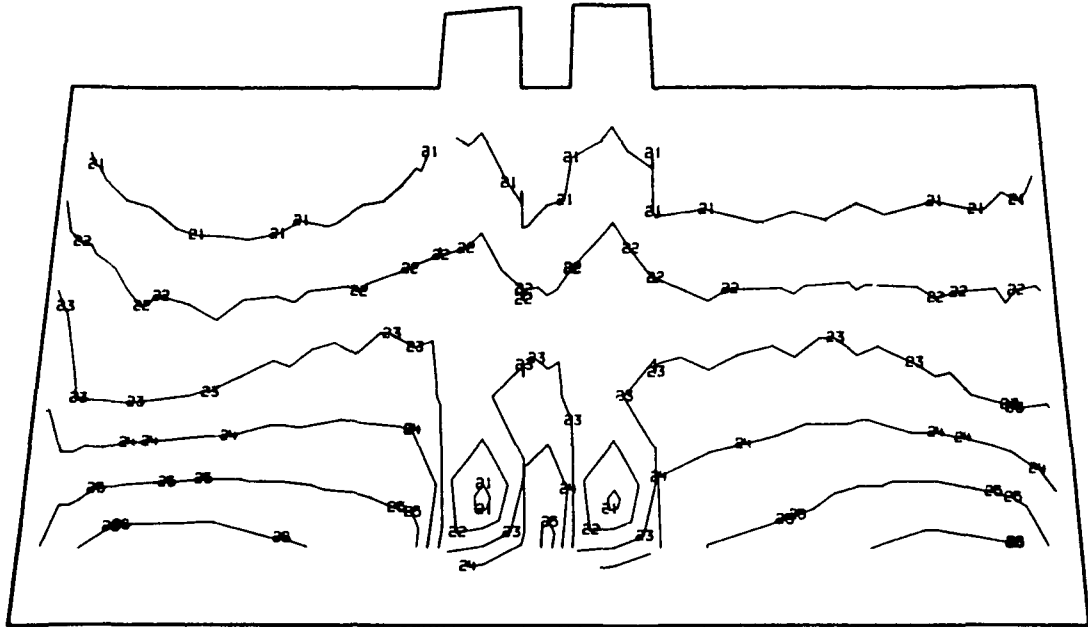

1	-1.500000E 05	12	-4.000000E 04	23	5.000000E 04
2	-1.400000E 05	13	-3.000000E 04	24	6.000000E 04
3	-1.300000E 05	14	-2.000000E 04	25	7.000000E 04
4	-1.200000E 05	15	-1.000000E 04	26	8.000000E 04
5	-1.100000E 05	16	-5.000000E 03	27	9.000000E 04
6	-1.000000E 05	17	0.0	28	1.000000E 05
7	-9.000000E 04	18	5.000000E 03	29	1.100000E 05
8	-8.000000E 04	19	1.000000E 04	30	1.200000E 05
9	-7.000000E 04	20	2.000000E 04	31	1.300000E 05
10	-6.000000E 04	21	3.000000E 04	32	1.400000E 05
11	-5.000000E 04	22	4.000000E 04	33	1.500000E 05

Fig. 2.5-31 Model 0-2, FPL Load, View 2, Shank Pressure Side
Maximum Principal Shear (psi)

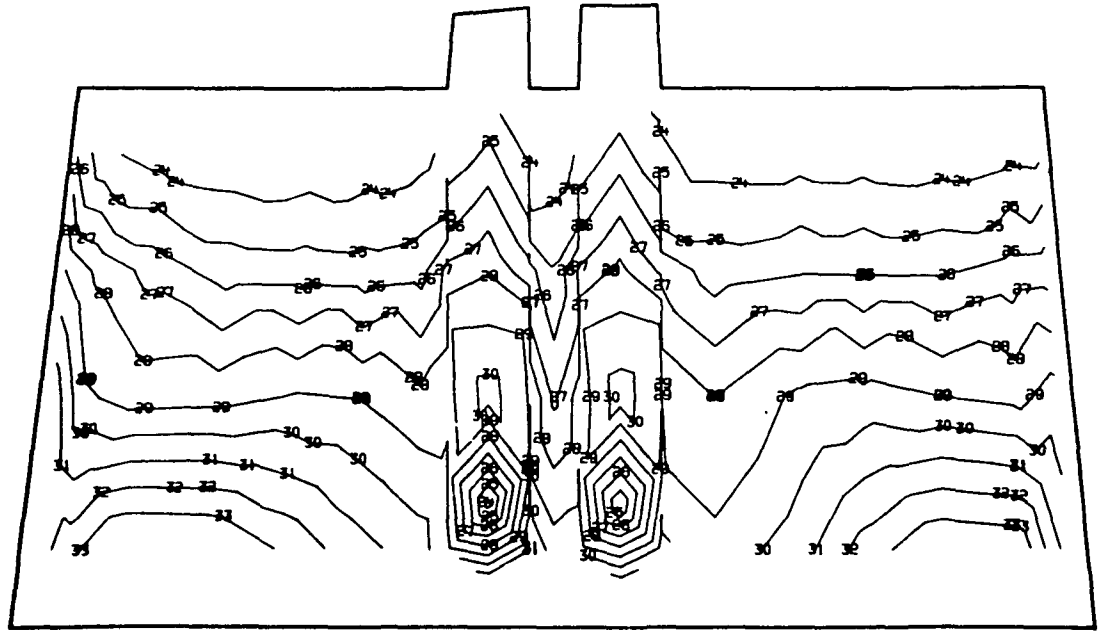

1	-1.500000E 05	12	-4.000000E 04	23	5.000000E 04
2	-1.400000E 05	13	-3.000000E 04	24	6.000000E 04
3	-1.300000E 05	14	-2.000000E 04	25	7.000000E 04
4	-1.200000E 05	15	-1.000000E 04	26	8.000000E 04
5	-1.100000E 05	16	-5.000000E 03	27	9.000000E 04
6	-1.000000E 05	17	0.0	28	1.000000E 05
7	-9.000000E 04	18	5.000000E 03	29	1.100000E 05
8	-8.000000E 04	19	1.000000E 04	30	1.200000E 05
9	-7.000000E 04	20	2.000000E 04	31	1.300000E 05
10	-6.000000E 04	21	3.000000E 04	32	1.400000E 05
11	-5.000000E 04	22	4.000000E 04	33	1.500000E 05

Fig. 2.5-32 Model 0-2, 115% Load, View 2, Shank Pressure Side
Major Principal Stress (psi)

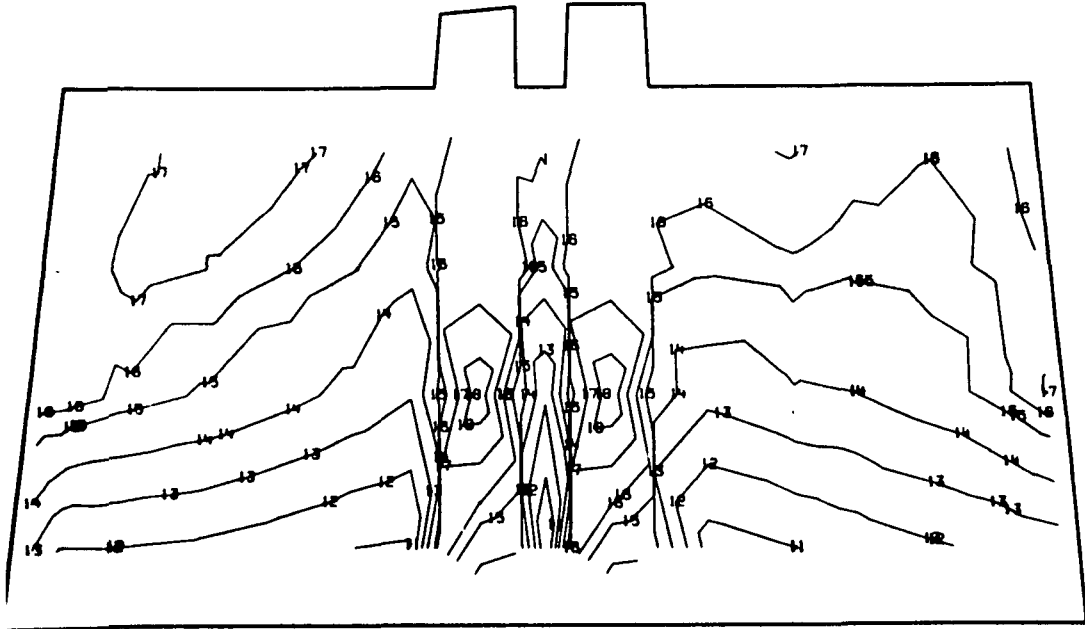

1	-1.500000E 05	05	12	-4.000000E 04	04	23	5.000000E 04	04
2	-1.400000E 05	05	13	-3.000000E 04	04	24	6.000000E 04	04
3	-1.300000E 05	05	14	-2.000000E 04	04	25	7.000000E 04	04
4	-1.200000E 05	05	15	-1.000000E 04	04	26	8.000000E 04	04
5	-1.100000E 05	05	16	-5.000000E 03	03	27	9.000000E 04	04
6	-1.000000E 05	05	17	0.0		28	1.000000E 05	05
7	-9.000000E 04	04	18	5.000000E 03	03	29	1.100000E 05	05
8	-8.000000E 04	04	19	1.000000E 04	04	30	1.200000E 05	05
9	-7.000000E 04	04	20	2.000000E 04	04	31	1.300000E 05	05
10	-6.000000E 04	04	21	3.000000E 04	04	32	1.400000E 05	05
11	-5.000000E 04	04	22	4.000000E 04	04	33	1.500000E 05	05

Fig. 2.5-33 Model 0-2, 115% Load, View 2, Shank Pressure Side
Minor Principal Stress (psi)

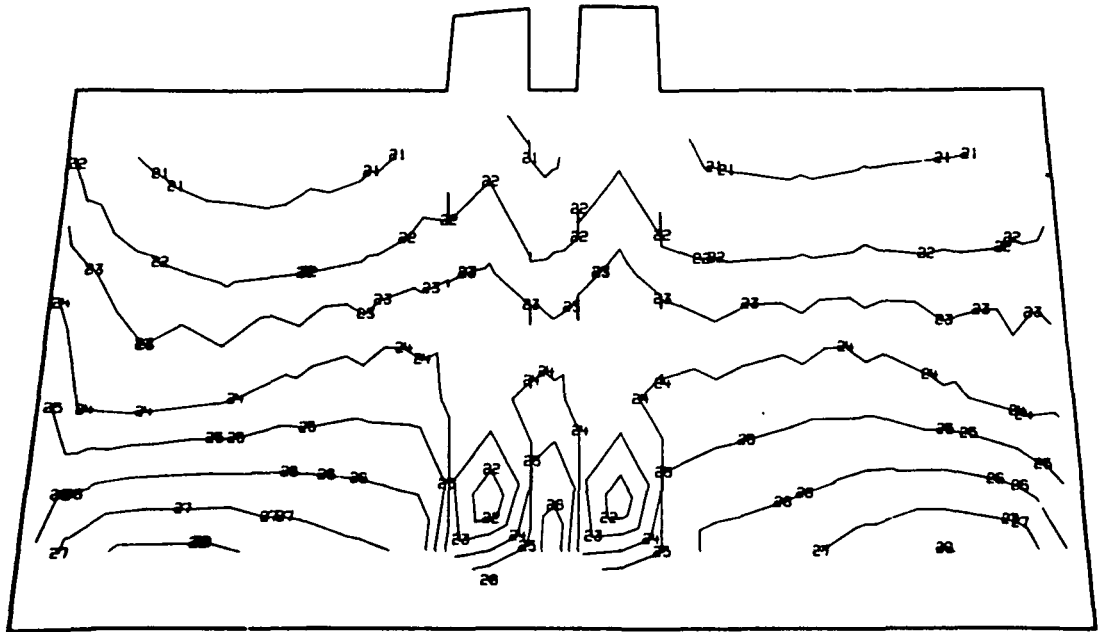

1	-1.500000E 05	12	-4.000000E 04	23	5.000000E 04
2	-1.400000E 05	13	-3.000000E 04	24	6.000000E 04
3	-1.300000E 05	14	-2.000000E 04	25	7.000000E 04
4	-1.200000E 05	15	-1.000000E 04	26	8.000000E 04
5	-1.100000E 05	16	-5.000000E 03	27	9.000000E 04
6	-1.000000E 05	17	0.0	28	1.000000E 05
7	-9.000000E 04	18	5.000000E 03	29	1.100000E 05
8	-8.000000E 04	19	1.000000E 04	30	1.200000E 05
9	-7.000000E 04	20	2.000000E 04	31	1.300000E 05
10	-6.000000E 04	21	3.000000E 04	32	1.400000E 05
11	-5.000000E 04	22	4.000000E 04	33	1.500000E 05

Fig. 2.5-34 Model 0-2, 115% Load, View 2, Shank Pressure Side
Maximum Principal Shear (psi)

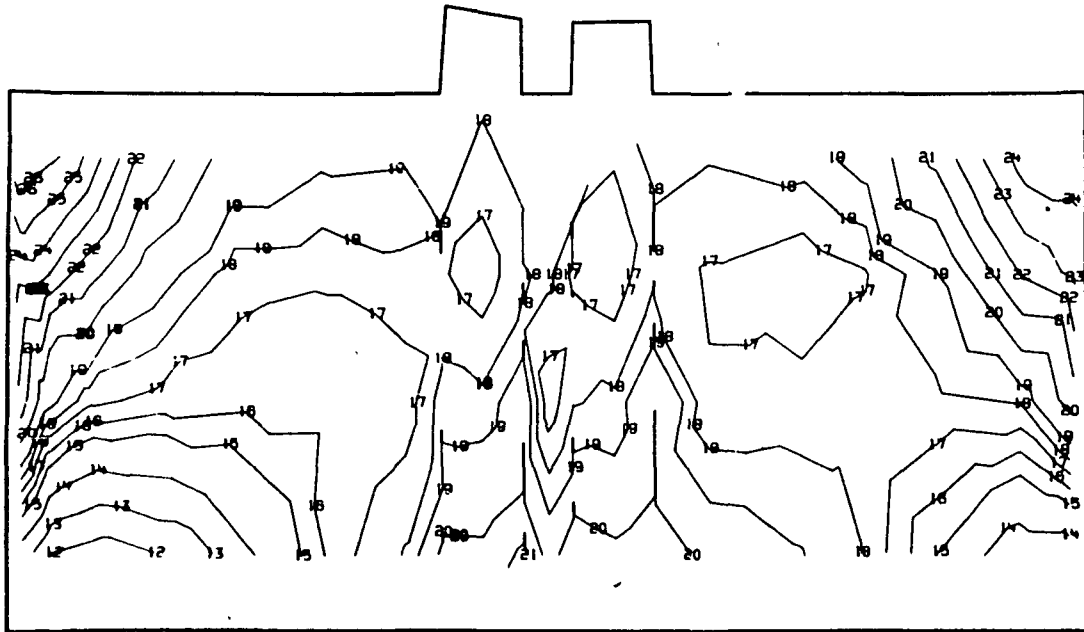

1	-1.500000E 05	12	-4.000000E 04	23	5.000000E 04
2	-1.400000E 05	13	-3.000000E 04	24	6.000000E 04
3	-1.300000E 05	14	-2.000000E 04	25	7.000000E 04
4	-1.200000E 05	15	-1.000000E 04	26	8.000000E 04
5	-1.100000E 05	16	-5.000000E 03	27	9.000000E 04
6	-1.000000E 05	17	0.0	28	1.000000E 05
7	-9.000000E 04	18	5.000000E 03	29	1.100000E 05
8	-8.000000E 04	19	1.000000E 04	30	1.200000E 05
9	-7.000000E 04	20	2.000000E 04	31	1.300000E 05
10	-6.000000E 04	21	3.000000E 04	32	1.400000E 05
11	-5.000000E 04	22	4.000000E 04	33	1.500000E 05

Fig. 2.5-35 Model 0-2, FPL Load, View 2, Shank Suction Side
Major Principal Stress (psi)

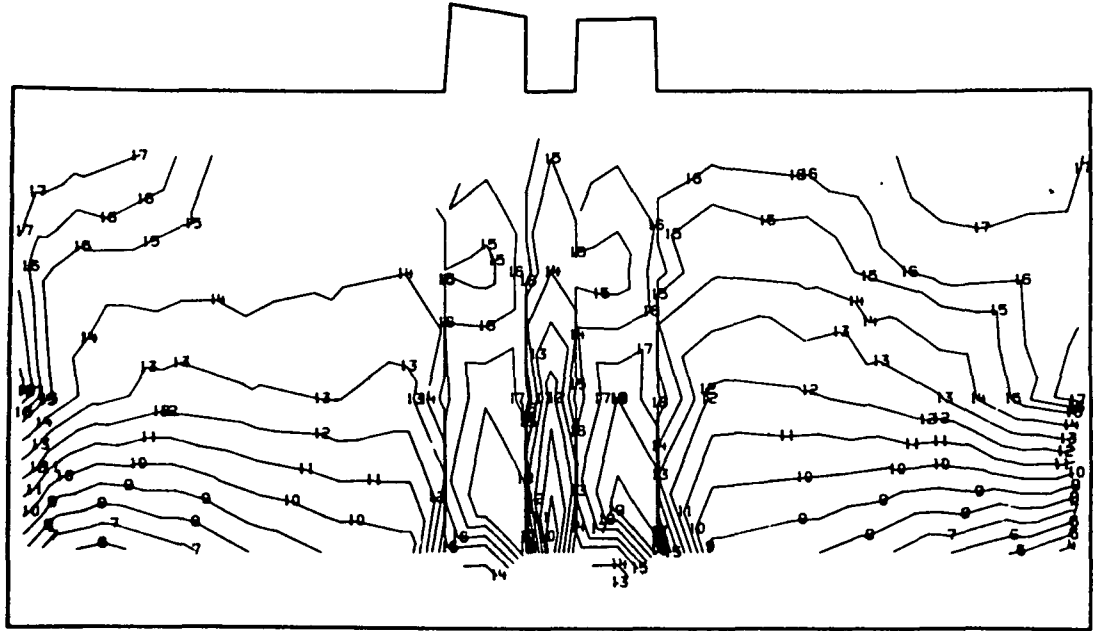

1	-1.500000E 05	12	-4.000000E 04	23	5.000000E 04
2	-1.400000E 05	13	-3.000000E 04	24	6.000000E 04
3	-1.300000E 05	14	-2.000000E 04	25	7.000000E 04
4	-1.200000E 05	15	-1.000000E 04	26	8.000000E 04
5	-1.100000E 05	16	-5.000000E 03	27	9.000000E 04
6	-1.000000E 05	17	0.0	28	1.000000E 05
7	-9.000000E 04	18	5.000000E 03	29	1.100000E 05
8	-8.000000E 04	19	1.000000E 04	30	1.200000E 05
9	-7.000000E 04	20	2.000000E 04	31	1.300000E 05
10	-6.000000E 04	21	3.000000E 04	32	1.400000E 05
11	-5.000000E 04	22	4.000000E 04	33	1.500000E 05

Fig. 2.5-36 Model 0-2, FPL Load, View 2, Shank Suction Side
Minor Principal Stress (psi)

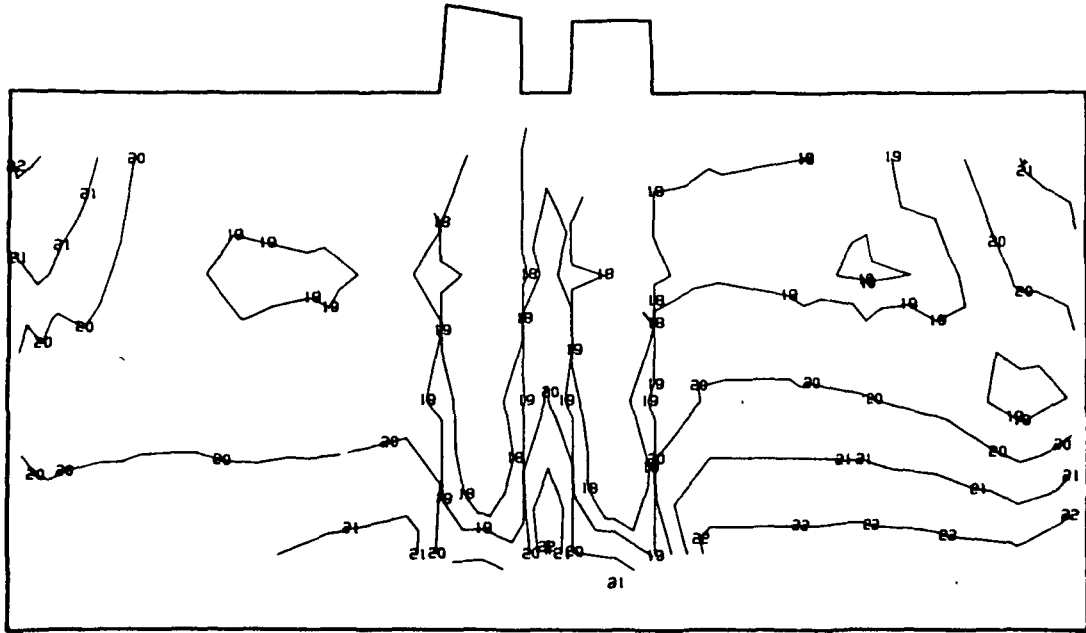

1	-1.500000E 05	12	-4.000000E 04	23	5.000000E 04
2	-1.400000E 05	13	-3.000000E 04	24	6.000000E 04
3	-1.300000E 05	14	-2.000000E 04	25	7.000000E 04
4	-1.200000E 05	15	-1.000000E 04	26	8.000000E 04
5	-1.100000E 05	16	-5.000000E 03	27	9.000000E 04
6	-1.000000E 05	17	0.0	28	1.000000E 05
7	-9.000000E 04	18	5.000000E 03	29	1.100000E 05
8	-8.000000E 04	19	1.000000E 04	30	1.200000E 05
9	-7.000000E 04	20	2.000000E 04	31	1.300000E 05
10	-6.000000E 04	21	3.000000E 04	32	1.400000E 05
11	-5.000000E 04	22	4.000000E 04	33	1.500000E 05

Fig. 2.5-37 Model 0-2, FPL Load, View 2, Shank Suction Side
Maximum Principal Shear (psi)

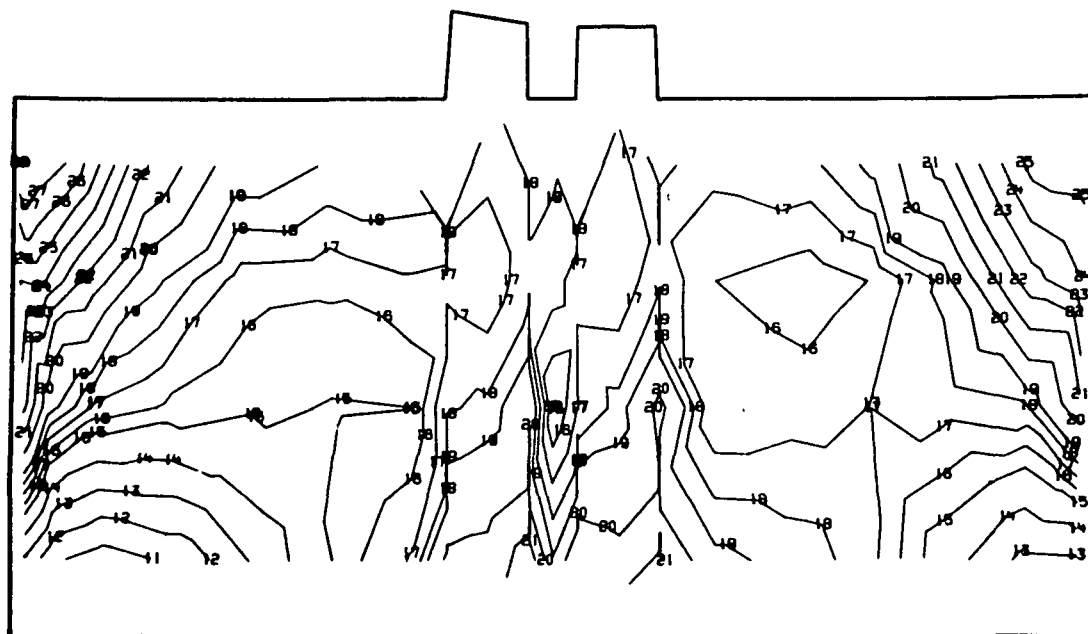

1	-1.500000E 05	12	-4.000000E 04	23	5.000000E 04
2	-1.400000E 05	13	-3.000000E 04	24	6.000000E 04
3	-1.300000E 05	14	-2.000000E 04	25	7.000000E 04
4	-1.200000E 05	15	-1.000000E 04	26	8.000000E 04
5	-1.100000E 05	16	-5.000000E 03	27	9.000000E 04
6	-1.000000E 05	17	0.0	28	1.000000E 05
7	-9.000000E 04	18	5.000000E 03	29	1.100000E 05
8	-8.000000E 04	19	1.000000E 04	30	1.200000E 05
9	-7.000000E 04	20	2.000000E 04	31	1.300000E 05
10	-6.000000E 04	21	3.000000E 04	32	1.400000E 05
11	-5.000000E 04	22	4.000000E 04	33	1.500000E 05

Fig. 2.5-38 Model 0-2, 115% Load, View 2, Shank Suction Side
Major Principal Stress (psi)

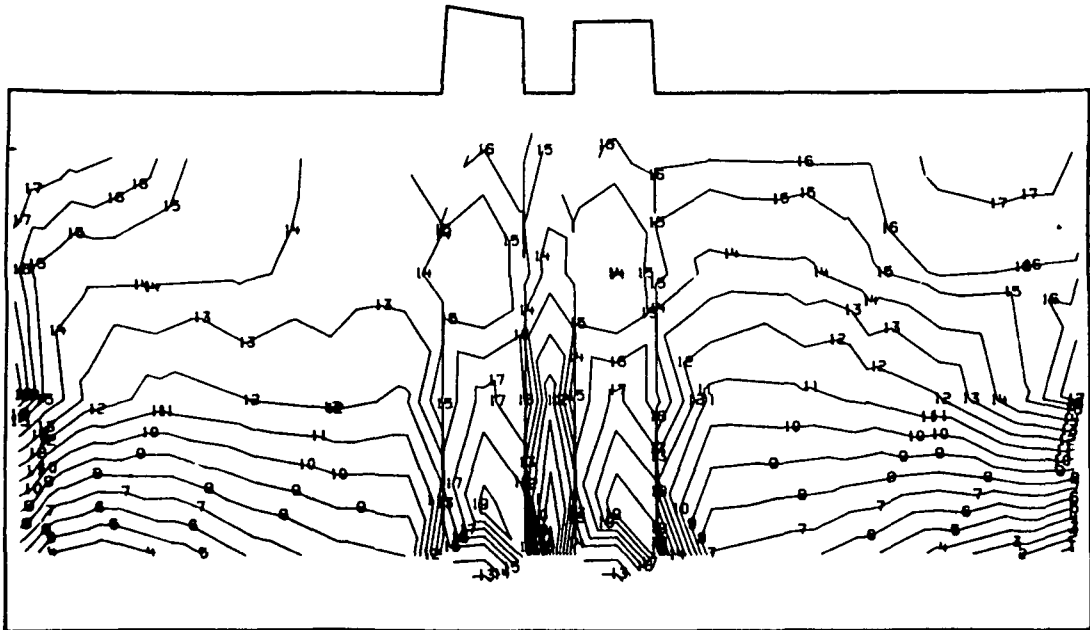

1	-1.500000E 05	12	-4.000000E 04	23	5.000000E 04
2	-1.400000E 05	13	-3.000000E 04	24	6.000000E 04
3	-1.300000E 05	14	-2.000000E 04	25	7.000000E 04
4	-1.200000E 05	15	-1.000000E 04	26	8.000000E 04
5	-1.100000E 05	16	-5.000000E 03	27	9.000000E 04
6	-1.000000E 05	17	0.0	28	1.000000E 05
7	-9.000000E 04	18	5.000000E 03	29	1.100000E 05
8	-8.000000E 04	19	1.000000E 04	30	1.200000E 05
9	-7.000000E 04	20	2.000000E 04	31	1.300000E 05
10	-6.000000E 04	21	3.000000E 04	32	1.400000E 05
11	-5.000000E 04	22	4.000000E 04	33	1.500000E 05

Fig. 2.5-39 Model 0-2, 115% Load, View 2, Shank Suction Side
Minor Principal Stress (psi)

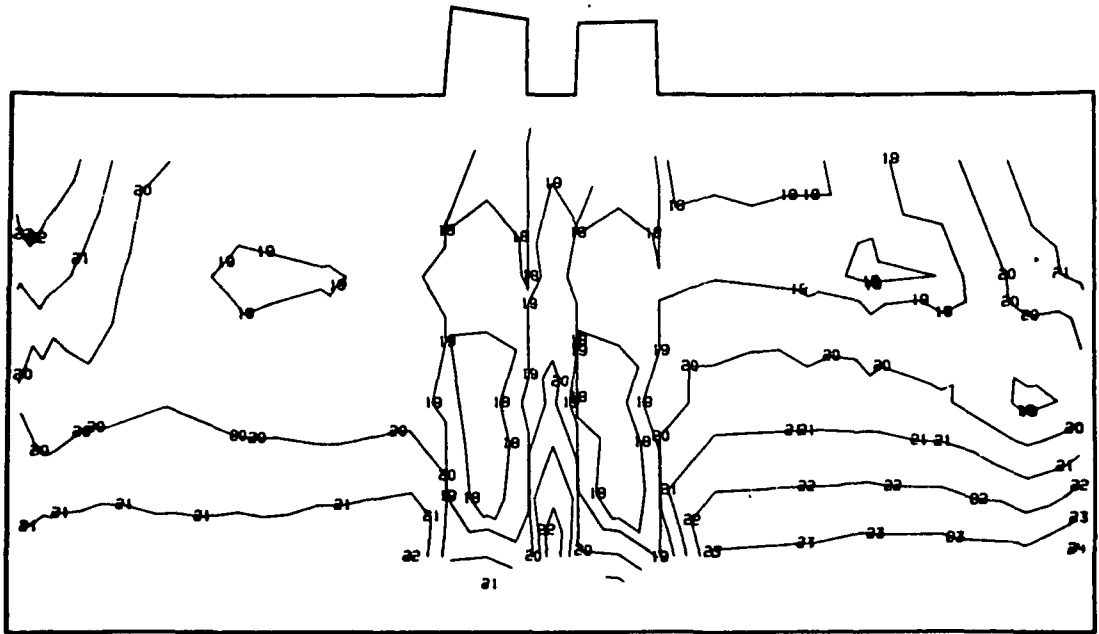

1	-1.500000E 05	12	-4.000000E 04	23	5.000000E 04
2	-1.400000E 05	13	-3.000000E 04	24	6.000000E 04
3	-1.300000E 05	14	-2.000000E 04	25	7.000000E 04
4	-1.200000E 05	15	-1.000000E 04	26	8.000000E 04
5	-1.100000E 05	16	-5.000000E 03	27	9.000000E 04
6	-1.000000E 05	17	0.0	28	1.000000E 05
7	-9.000000E 04	18	5.000000E 03	29	1.100000E 05
8	-8.000000E 04	19	1.000000E 04	30	1.200000E 05
9	-7.000000E 04	20	2.000000E 04	31	1.300000E 05
10	-6.000000E 04	21	3.000000E 04	32	1.400000E 05
11	-5.000000E 04	22	4.000000E 04	33	1.500000E 05

Fig. 2.5-40 Model 0-2, 115% Load, View 2, Shank Suction Side
Maximum Principal Shear (psi)

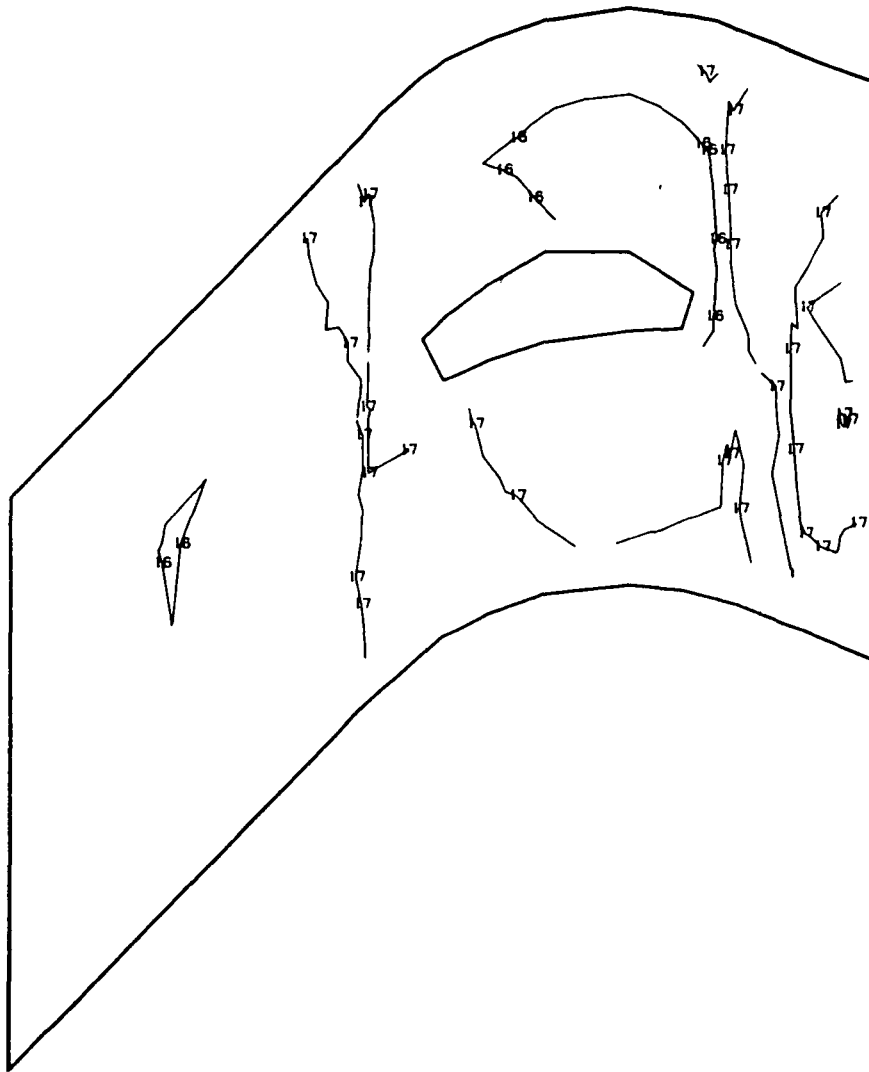

1	-1.500000E 05		12	-4.000000E 04		23	5.000000E 04
2	-1.400000E 05		13	-3.000000E 04		24	6.000000E 04
3	-1.300000E 05		14	-2.000000E 04		25	7.000000E 04
4	-1.200000E 05		15	-1.000000E 04		26	8.000000E 04
5	-1.100000E 05		16	-5.000000E 03		27	9.000000E 04
6	-1.000000E 05		17	0.0		28	1.000000E 05
7	-9.000000E 04		18	5.000000E 03		29	1.100000E 05
8	-8.000000E 04		19	1.000000E 04		30	1.200000E 05
9	-7.000000E 04		20	2.000000E 04		31	1.300000E 05
10	-6.000000E 04		21	3.000000E 04		32	1.400000E 05
11	-5.000000E 04		22	4.000000E 04		33	1.500000E 05

Fig. 2.5-41 Model 0-2, FPL Load, View 3, Shroud Top
Major Principal Stress (psi)

2.5-41

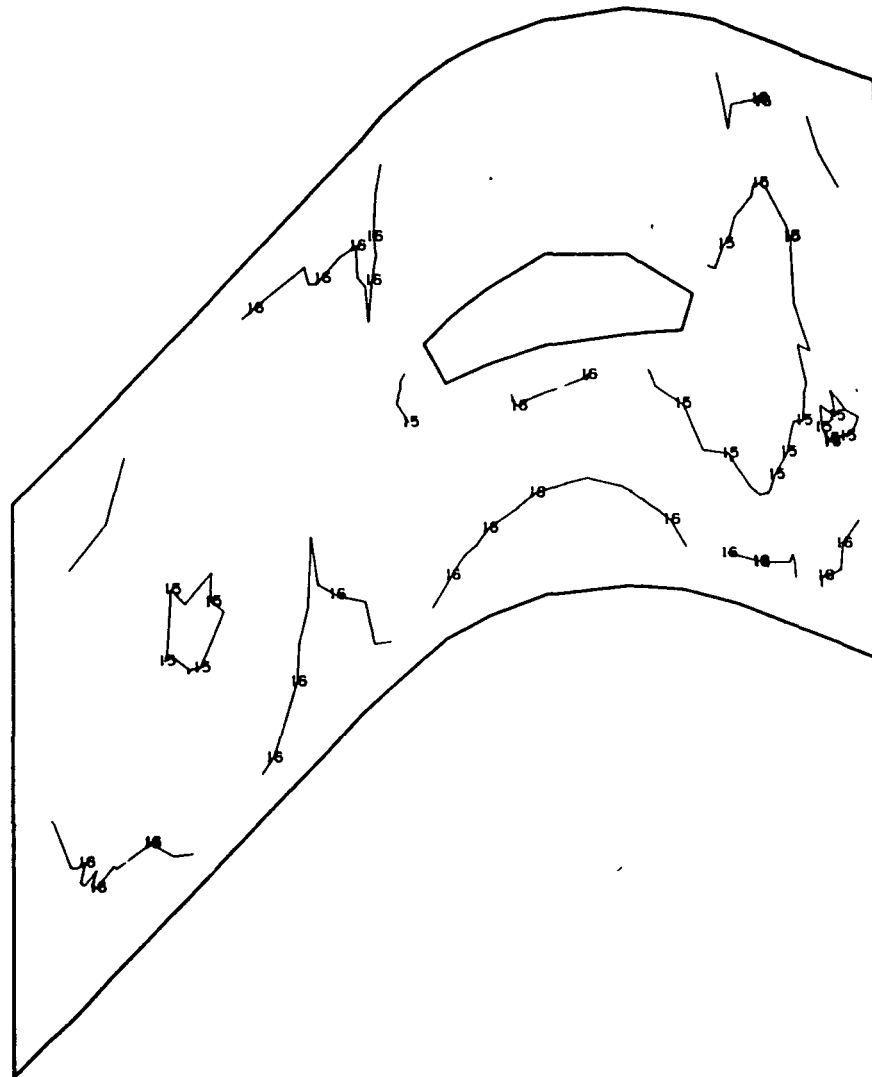

1	-1.500000E 05	12	-4.000000E 04	23	5.000000E 04
2	-1.400000E 05	13	-3.000000E 04	24	6.000000E 04
3	-1.300000E 05	14	-2.000000E 04	25	7.000000E 04
4	-1.200000E 05	15	-1.000000E 04	26	8.000000E 04
5	-1.100000E 05	16	-5.000000E 03	27	9.000000E 04
6	-1.000000E 05	17	0.0	28	1.000000E 05
7	-9.000000E 04	18	5.000000E 03	29	1.100000E 05
8	-8.000000E 04	19	1.000000E 04	30	1.200000E 05
9	-7.000000E 04	20	2.000000E 04	31	1.300000E 05
10	-6.000000E 04	21	3.000000E 04	32	1.400000E 05
11	-5.000000E 04	22	4.000000E 04	33	1.500000E 05

Fig. 2.5-42 Model 0-2, FPL Load, View 3, Shroud Top
Minor Principal Stress (psi)

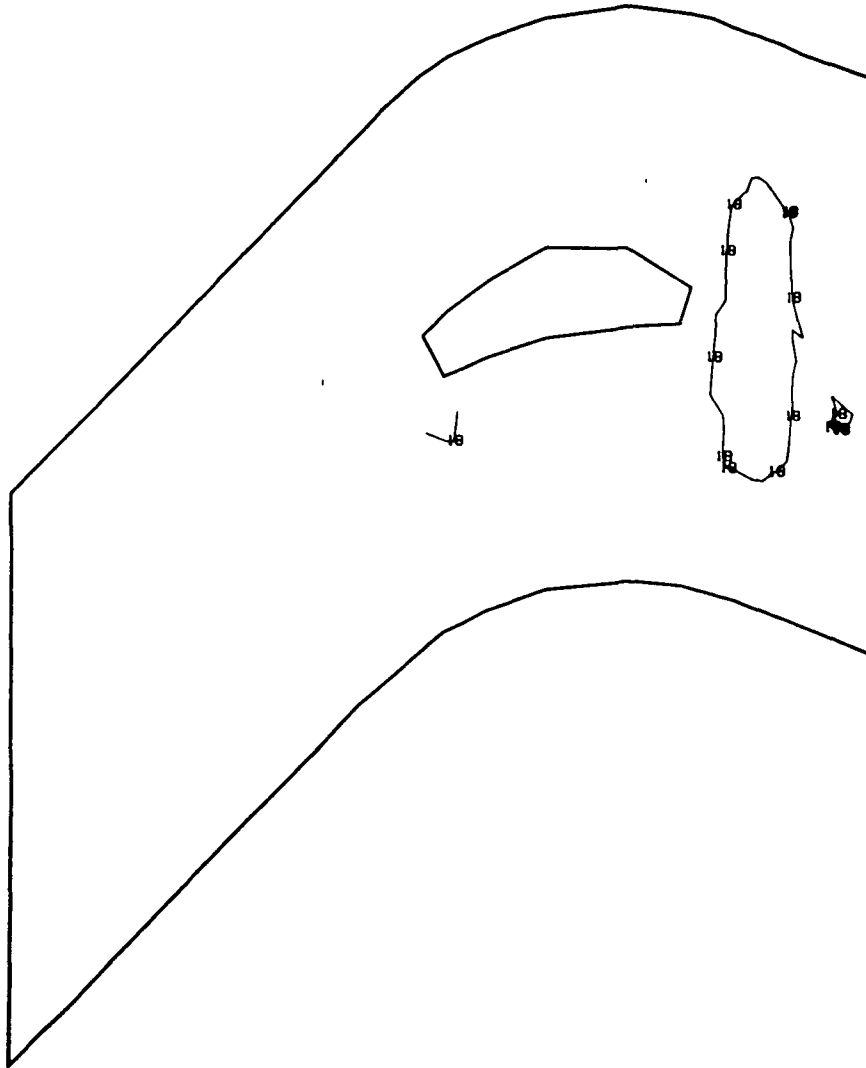

1	-1.500000E 05	12	-4.000000E 04	23	5.000000E 04
2	-1.400000E 05	13	-3.000000E 04	24	6.000000E 04
3	-1.300000E 05	14	-2.000000E 04	25	7.000000E 04
4	-1.200000E 05	15	-1.000000E 04	26	8.000000E 04
5	-1.100000E 05	16	-5.000000E 03	27	9.000000E 04
6	-1.000000E 05	17	0.0	28	1.000000E 05
7	-9.000000E 04	18	5.000000E 03	29	1.100000E 05
8	-8.000000E 04	19	1.000000E 04	30	1.200000E 05
9	-7.000000E 04	20	2.000000E 04	31	1.300000E 05
10	-6.000000E 04	21	3.000000E 04	32	1.400000E 05
11	-5.000000E 04	22	4.000000E 04	33	1.500000E 05

Fig. 2.5-43 Model 0-2, FPL Load, View 3, Shroud Top
Maximum Principal Shear (psi)

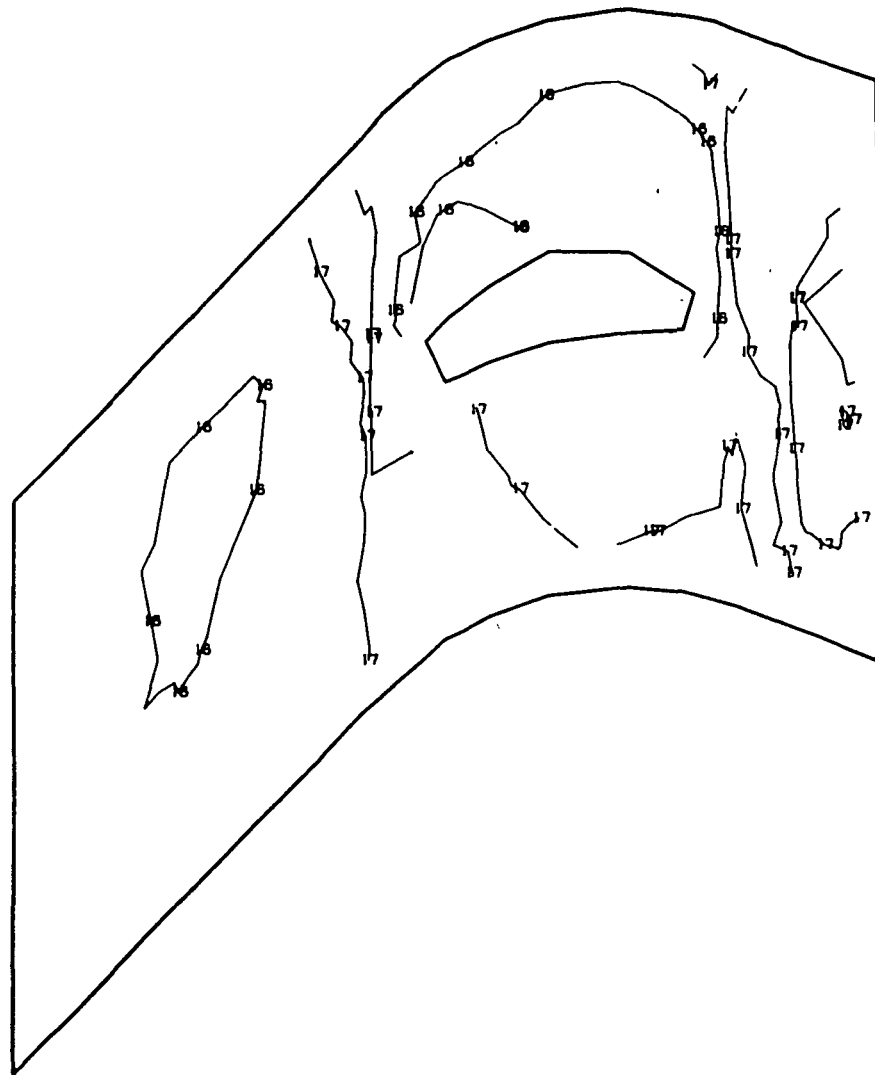

1	-1.500000E 05	12	-4.000000E 04	23	5.000000E 04
2	-1.400000E 05	13	-3.000000E 04	24	6.000000E 04
3	-1.300000E 05	14	-2.000000E 04	25	7.000000E 04
4	-1.200000E 05	15	-1.000000E 04	26	8.000000E 04
5	-1.100000E 05	16	-5.000000E 03	27	9.000000E 04
6	-1.000000E 05	17	0.0	28	1.000000E 05
7	-9.000000E 04	18	5.000000E 03	29	1.100000E 05
8	-8.000000E 04	19	1.000000E 04	30	1.200000E 05
9	-7.000000E 04	20	2.000000E 04	31	1.300000E 05
10	-6.000000E 04	21	3.000000E 04	32	1.400000E 05
11	-5.000000E 04	22	4.000000E 04	33	1.500000E 05

Fig. 2.5-44 Model 0-2, 115% Load, View 3, Shroud Top
Major Principal Stress (psi)

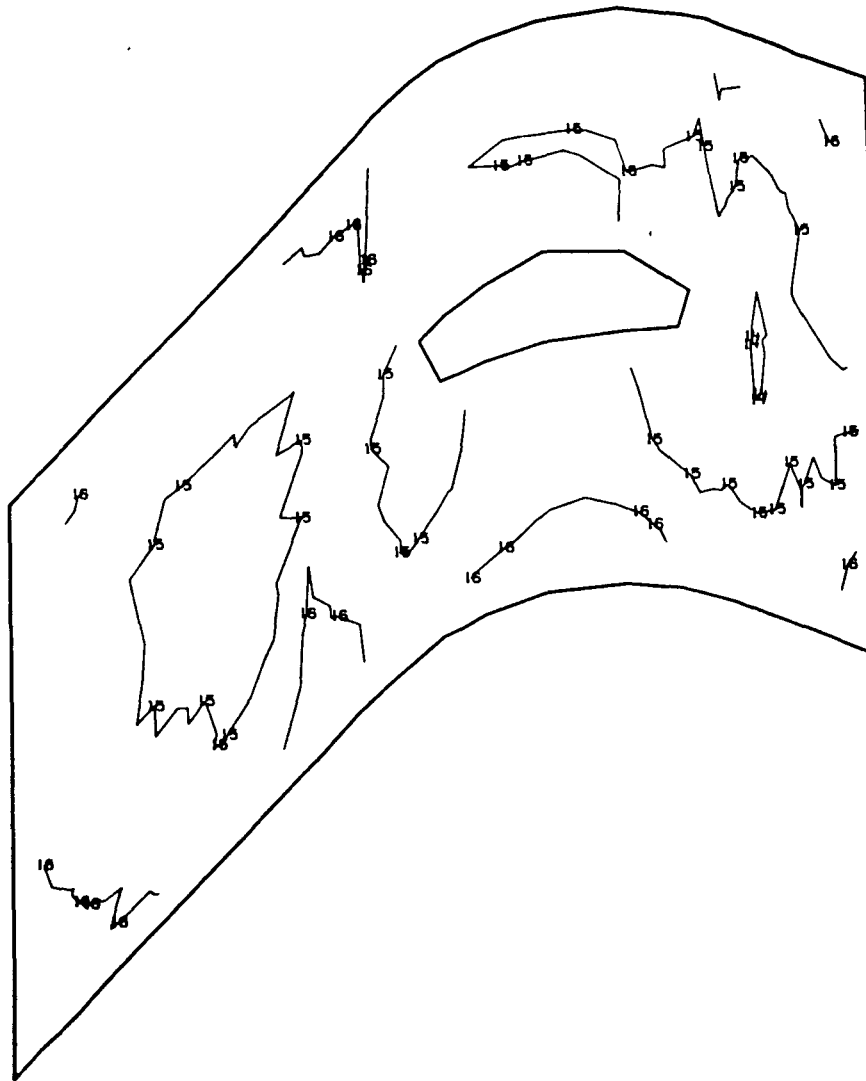

1	-1.500000E 05	12	-4.000000E 04	23	5.000000E 04
2	-1.400000E 05	13	-3.000000E 04	24	6.000000E 04
3	-1.300000E 05	14	-2.000000E 04	25	7.000000E 04
4	-1.200000E 05	15	-1.000000E 04	26	8.000000E 04
5	-1.100000E 05	16	-5.000000E 03	27	9.000000E 04
6	-1.000000E 05	17	0.0	28	1.000000E 05
7	-9.000000E 04	18	5.000000E 03	29	1.100000E 05
8	-8.000000E 04	19	1.000000E 04	30	1.200000E 05
9	-7.000000E 04	20	2.000000E 04	31	1.300000E 05
10	-6.000000E 04	21	3.000000E 04	32	1.400000E 05
11	-5.000000E 04	22	4.000000E 04	33	1.500000E 05

Fig. 2.5-45 Model 0-2, 115% Load, View 3, Shroud Top
Minor Principal Stress (psi)

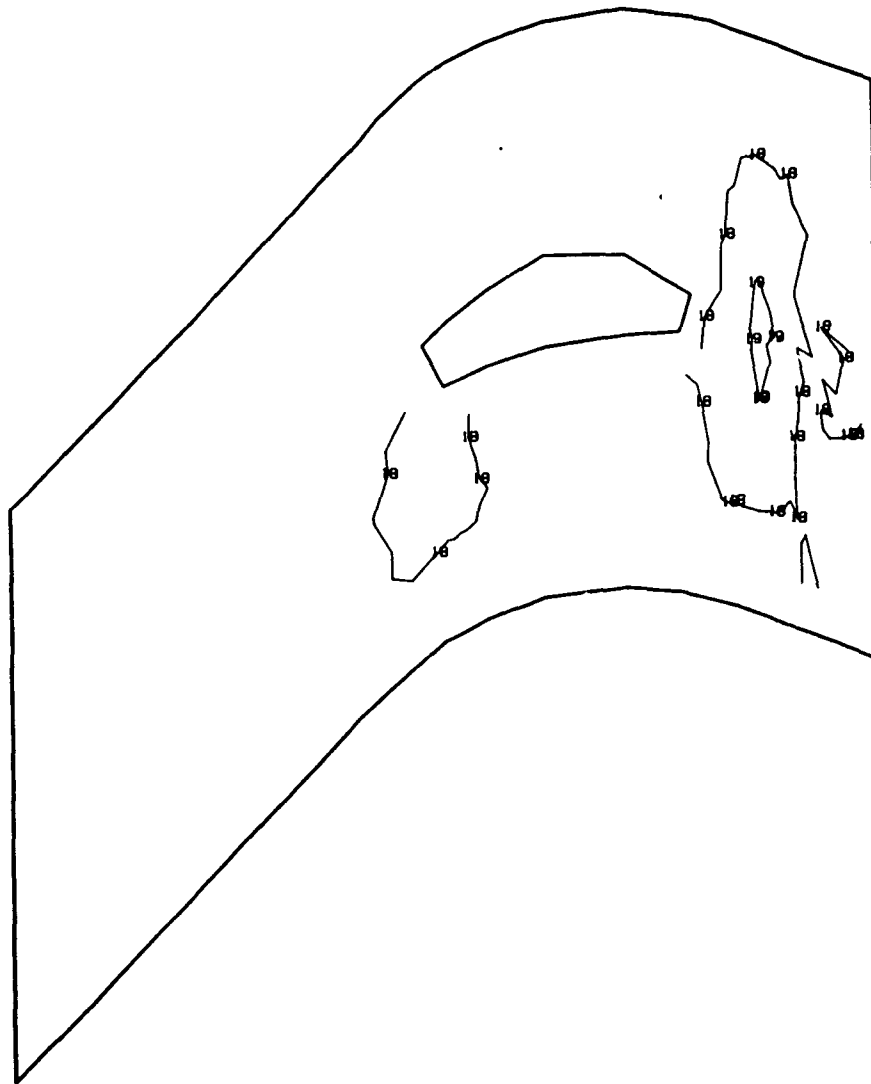

1	-1.500000E 05	12	-4.000000E 04	23	5.000000E 04
2	-1.400000E 05	13	-3.000000E 04	24	6.000000E 04
3	-1.300000E 05	14	-2.000000E 04	25	7.000000E 04
4	-1.200000E 05	15	-1.000000E 04	26	8.000000E 04
5	-1.100000E 05	16	-5.000000E 03	27	9.000000E 04
6	-1.000000E 05	17	0.0	28	1.000000E 05
7	-9.000000E 04	18	5.000000E 03	29	1.100000E 05
8	-8.000000E 04	19	1.000000E 04	30	1.200000E 05
9	-7.000000E 04	20	2.000000E 04	31	1.300000E 05
10	-6.000000E 04	21	3.000000E 04	32	1.400000E 05
11	-5.000000E 04	22	4.000000E 04	33	1.500000E 05

Fig. 2.5-46 Model 0-2, 115% Load, View 3, Shroud Top
Maximum Principal Shear (psi)

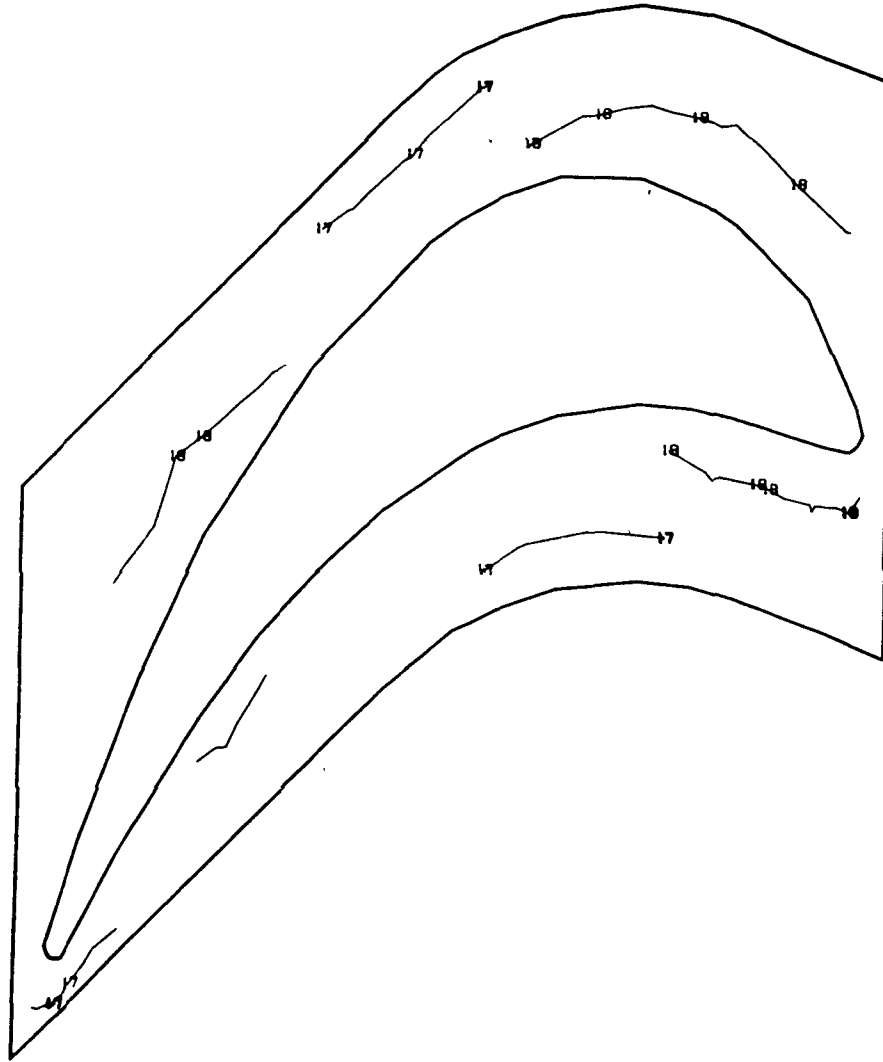

1	-1.500000E 05	12	-4.000000E 04	23	5.000000E 04
2	-1.400000E 05	13	-3.000000E 04	24	6.000000E 04
3	-1.300000E 05	14	-2.000000E 04	25	7.000000E 04
4	-1.200000E 05	15	-1.000000E 04	26	8.000000E 04
5	-1.100000E 05	16	-5.000000E 03	27	9.000000E 04
6	-1.000000E 05	17	0.0	28	1.000000E 05
7	-9.000000E 04	18	5.000000E 03	29	1.100000E 05
8	-8.000000E 04	19	1.000000E 04	30	1.200000E 05
9	-7.000000E 04	20	2.000000E 04	31	1.300000E 05
10	-6.000000E 04	21	3.000000E 04	32	1.400000E 05
11	-5.000000E 04	22	4.000000E 04	33	1.500000E 05

Fig. 2.5-47 Model 0-2, FPL Load, View 3, Shroud Bottom Major Principal Stress (psi)

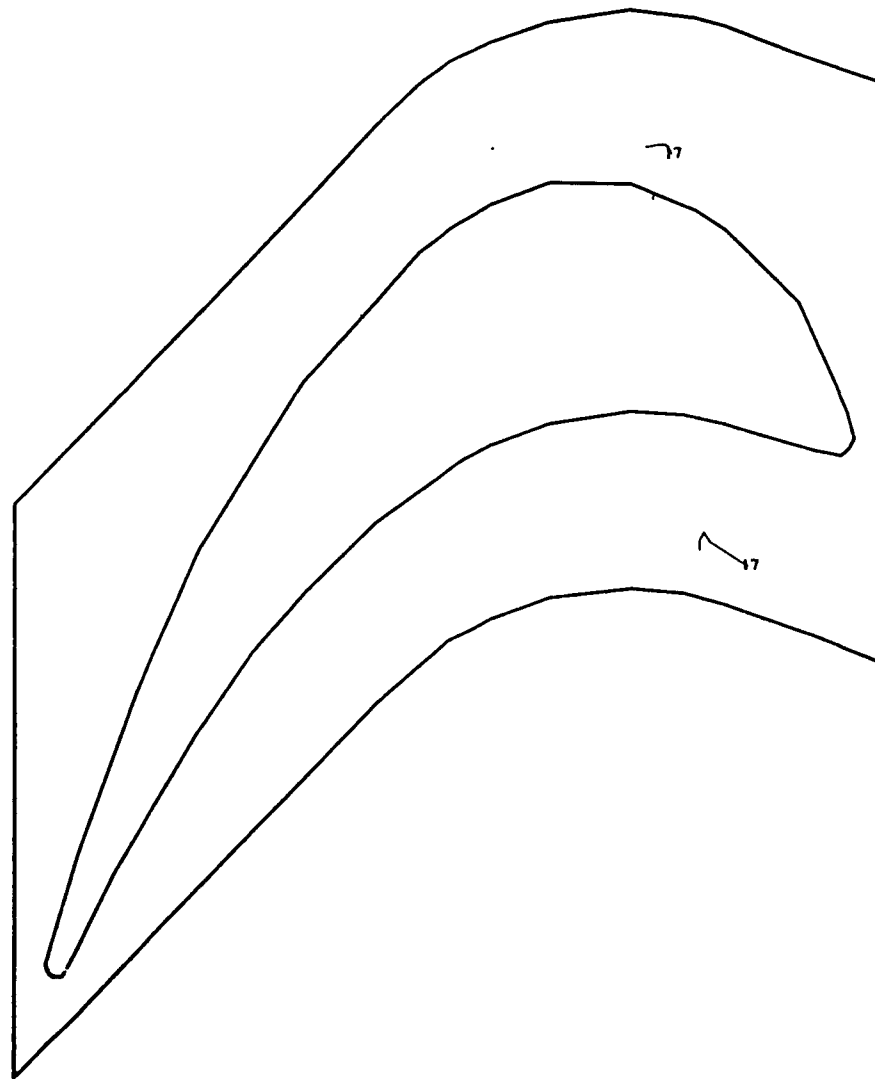

1	-1.500000E 05	12	-4.000000E 04	23	5.000000E 04
2	-1.400000E 05	13	-3.000000E 04	24	6.000000E 04
3	-1.300000E 05	14	-2.000000E 04	25	7.000000E 04
4	-1.200000E 05	15	-1.000000E 04	26	8.000000E 04
5	-1.100000E 05	16	-5.000000E 03	27	9.000000E 04
6	-1.000000E 05	17	0.0	28	1.000000E 05
7	-9.000000E 04	18	5.000000E 03	29	1.100000E 05
8	-8.000000E 04	19	1.000000E 04	30	1.200000E 05
9	-7.000000E 04	20	2.000000E 04	31	1.300000E 05
10	-6.000000E 04	21	3.000000E 04	32	1.400000E 05
11	-5.000000E 04	22	4.000000E 04	33	1.500000E 05

Fig. 2.5-48 Model 0-2, FPL Load, View 3, Shroud Bottom
Minor Principal Stress (psi)

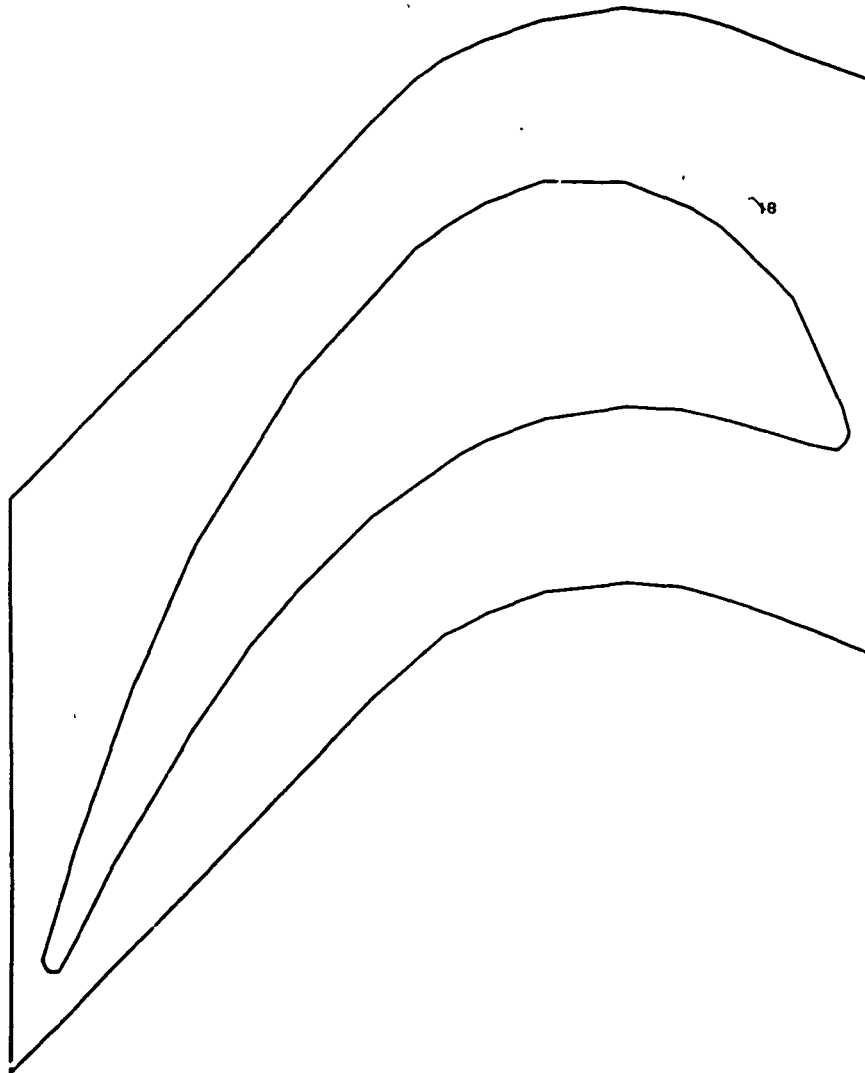

1	-1.500000E 05	12	-4.000000E 04	23	5.000000E 04
2	-1.400000E 05	13	-3.000000E 04	24	6.000000E 04
3	-1.300000E 05	14	-2.000000E 04	25	7.000000E 04
4	-1.200000E 05	15	-1.000000E 04	26	8.000000E 04
5	-1.100000E 05	16	-5.000000E 03	27	9.000000E 04
6	-1.000000E 05	17	0.0	28	1.000000E 05
7	-9.000000E 04	18	5.000000E 03	29	1.100000E 05
8	-8.000000E 04	19	1.000000E 04	30	1.200000E 05
9	-7.000000E 04	20	2.000000E 04	31	1.300000E 05
10	-6.000000E 04	21	3.000000E 04	32	1.400000E 05
11	-5.000000E 04	22	4.000000E 04	33	1.500000E 05

Fig. 2.5-49 Model 0-2, FPL Load, View 3, Shroud Bottom
Maximum Principal Shear (psi)

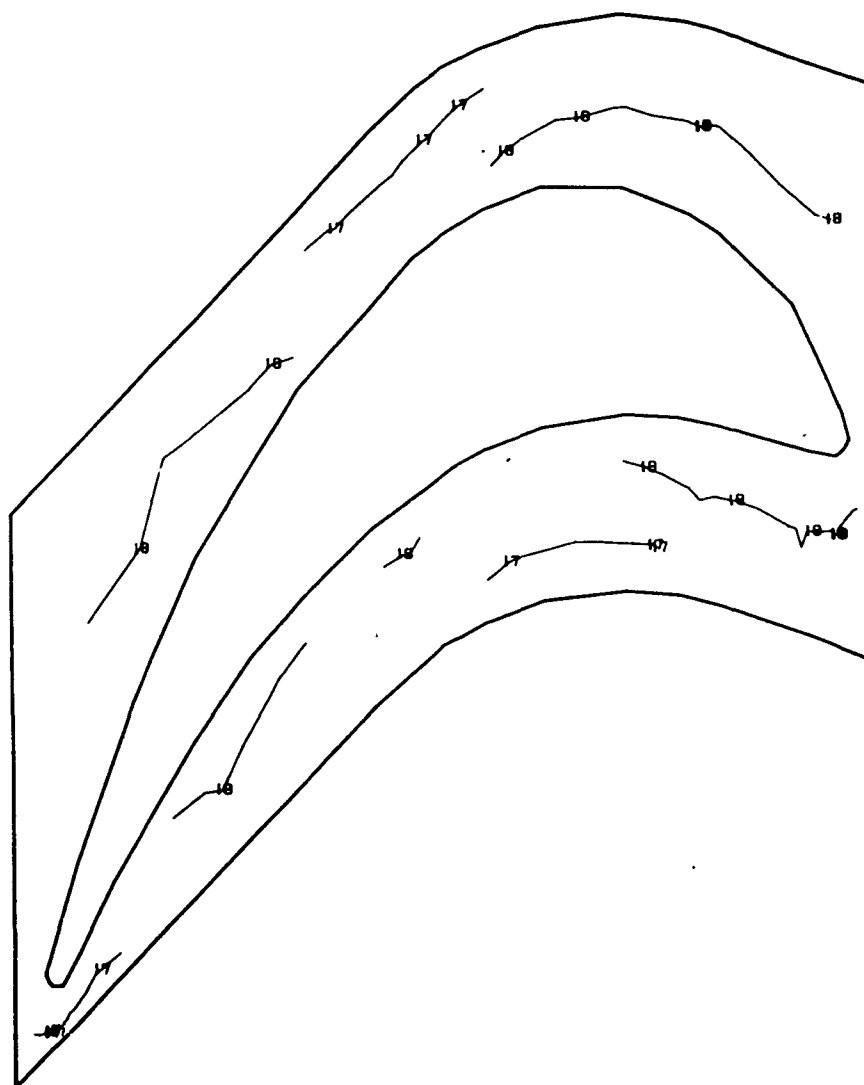

1	-1.500000E 05	05	12	-4.000000E 04	04	23	5.000000E 04	04
2	-1.400000E 05	05	13	-3.000000E 04	04	24	6.000000E 04	04
3	-1.300000E 05	05	14	-2.000000E 04	04	25	7.000000E 04	04
4	-1.200000E 05	05	15	-1.000000E 04	04	26	8.000000E 04	04
5	-1.100000E 05	05	16	-5.000000E 03	03	27	9.000000E 04	04
6	-1.000000E 05	05	17	0.0		28	1.000000E 05	05
7	-9.000000E 04	04	18	5.000000E 03	03	29	1.100000E 05	05
8	-8.000000E 04	04	19	1.000000E 04	04	30	1.200000E 05	05
9	-7.000000E 04	04	20	2.000000E 04	04	31	1.300000E 05	05
10	-6.000000E 04	04	21	3.000000E 04	04	32	1.400000E 05	05
11	-5.000000E 04	04	22	4.000000E 04	04	33	1.500000E 05	05

Fig. 2.5-50 Model 0-2, 115% Load, View 3, Shroud Bottom
Major Principal Stress (psi)

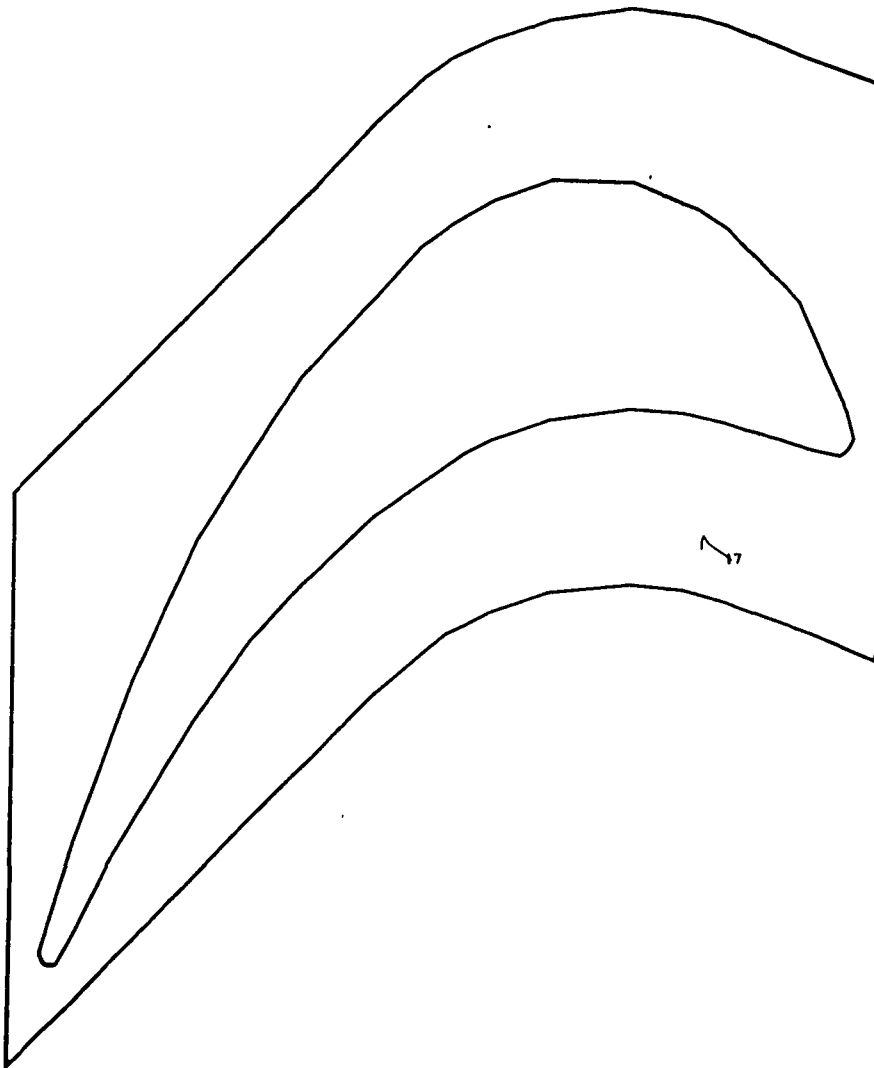

1	-1.500000E 05	12	-4.000000E 04	23	5.000000E 04
2	-1.400000E 05	13	-3.000000E 04	24	6.000000E 04
3	-1.300000E 05	14	-2.000000E 04	25	7.000000E 04
4	-1.200000E 05	15	-1.000000E 04	26	8.000000E 04
5	-1.100000E 05	16	-5.000000E 03	27	9.000000E 04
6	-1.000000E 05	17	0.0	28	1.000000E 05
7	-9.000000E 04	18	5.000000E 03	29	1.100000E 05
8	-8.000000E 04	19	1.000000E 04	30	1.200000E 05
9	-7.000000E 04	20	2.000000E 04	31	1.300000E 05
10	-6.000000E 04	21	3.000000E 04	32	1.400000E 05
11	-5.000000E 04	22	4.000000E 04	33	1.500000E 05

Fig. 2.5-51 Model 0-2, 115% Load, View 3, Shroud Bottom
Minor Principal Stress (psi)

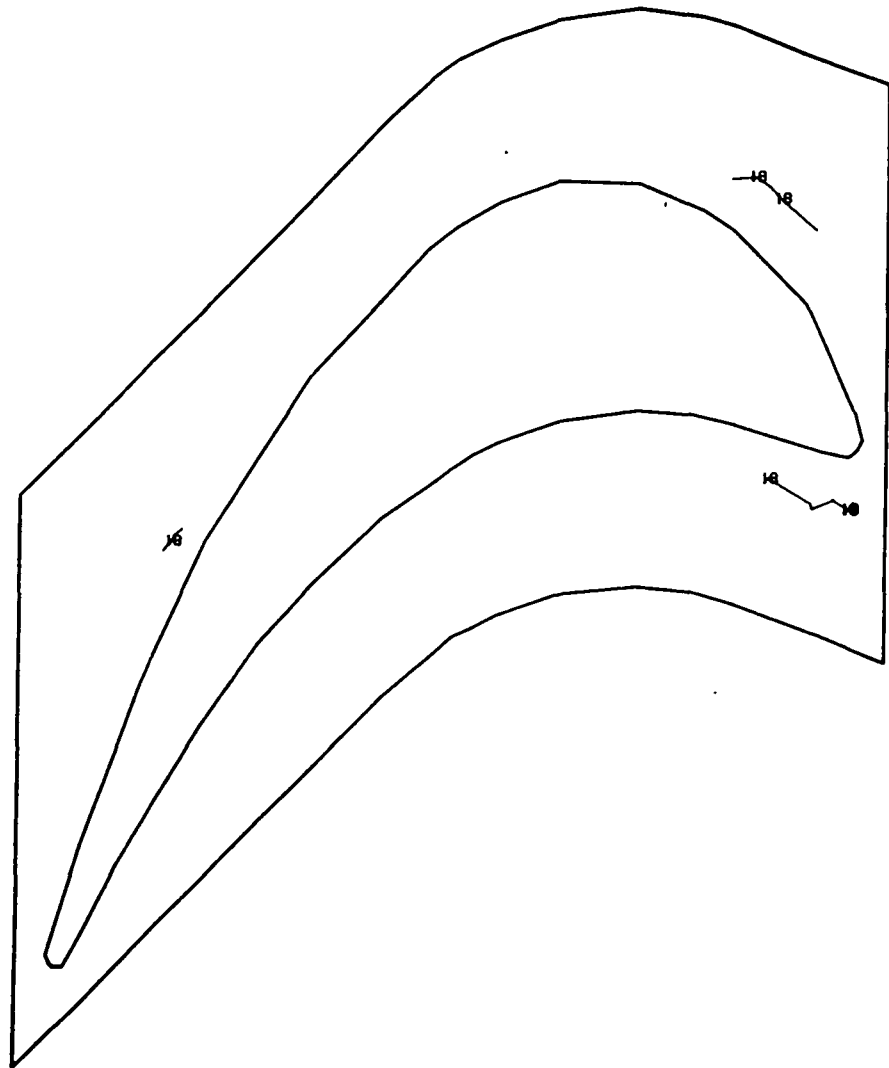

1	-1.500000E 05	12	-4.000000E 04	23	5.000000E 04
2	-1.400000E 05	13	-3.000000E 04	24	6.000000E 04
3	-1.300000E 05	14	-2.000000E 04	25	7.000000E 04
4	-1.200000E 05	15	-1.000000E 04	26	8.000000E 04
5	-1.100000E 05	16	-5.000000E 03	27	9.000000E 04
6	-1.000000E 05	17	0.0	28	1.000000E 05
7	-9.000000E 04	18	5.000000E 03	29	1.100000E 05
8	-8.000000E 04	19	1.000000E 04	30	1.200000E 05
9	-7.000000E 04	20	2.000000E 04	31	1.300000E 05
10	-6.000000E 04	21	3.000000E 04	32	1.400000E 05
11	-5.000000E 04	22	4.000000E 04	33	1.500000E 05

Fig. 2.5-52 Model 0-2, 115% Load, View 3, Shroud Bottom
Maximum Principal Shear (psi)

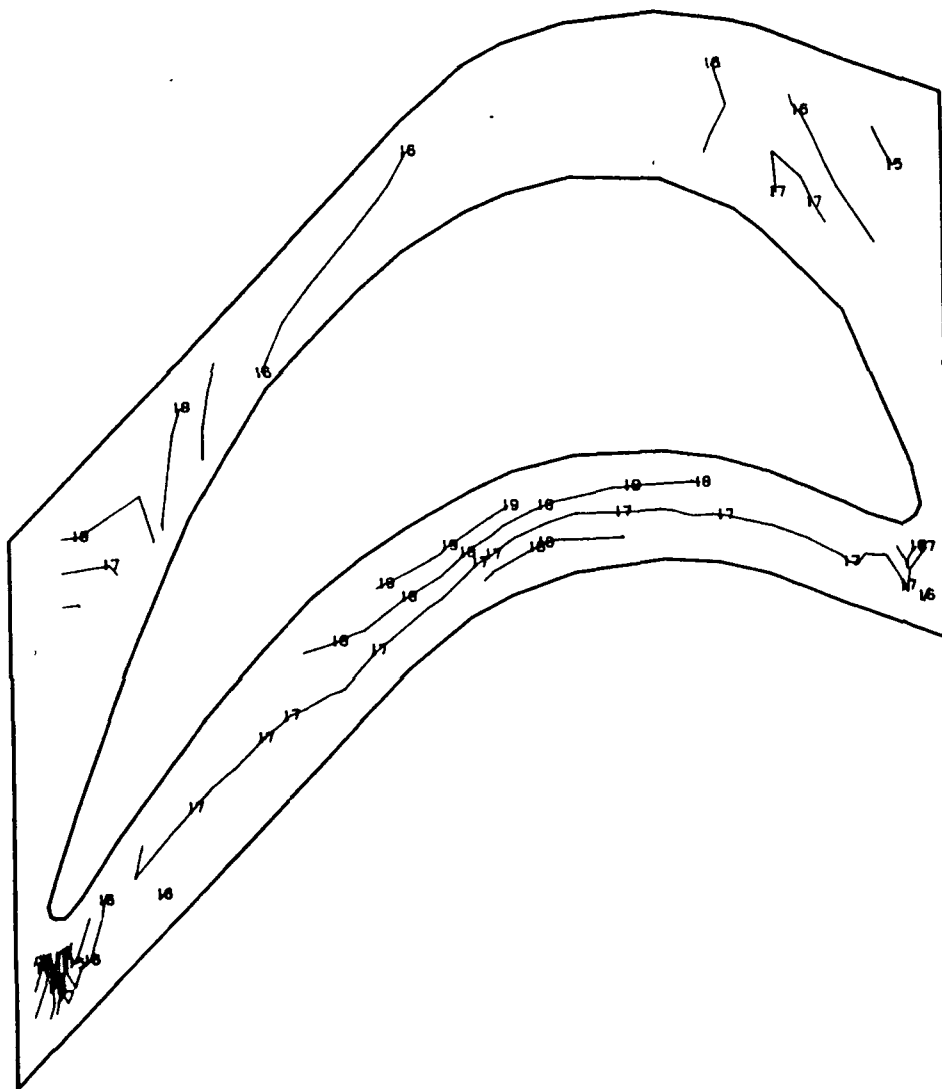

1	-1.500000E 05	05	12	-4.000000E 04	04	23	5.000000E 04	04
2	-1.400000E 05	05	13	-3.000000E 04	04	24	6.000000E 04	04
3	-1.300000E 05	05	14	-2.000000E 04	04	25	7.000000E 04	04
4	-1.200000E 05	05	15	-1.000000E 04	04	26	8.000000E 04	04
5	-1.100000E 05	05	16	-5.000000E 03	03	27	9.000000E 04	04
6	-1.000000E 05	05	17	0.0		28	1.000000E 05	05
7	-9.000000E 04	04	18	5.000000E 03	03	29	1.100000E 05	05
8	-8.000000E 04	04	19	1.000000E 04	04	30	1.200000E 05	05
9	-7.000000E 04	04	20	2.000000E 04	04	31	1.300000E 05	05
10	-6.000000E 04	04	21	3.000000E 04	04	32	1.400000E 05	05
11	-5.000000E 04	04	22	4.000000E 04	04	33	1.500000E 05	05

Fig. 2.5-53 Model 0-2, FPL Load, View 3, Platform Top
Major Principal Stress (psi)

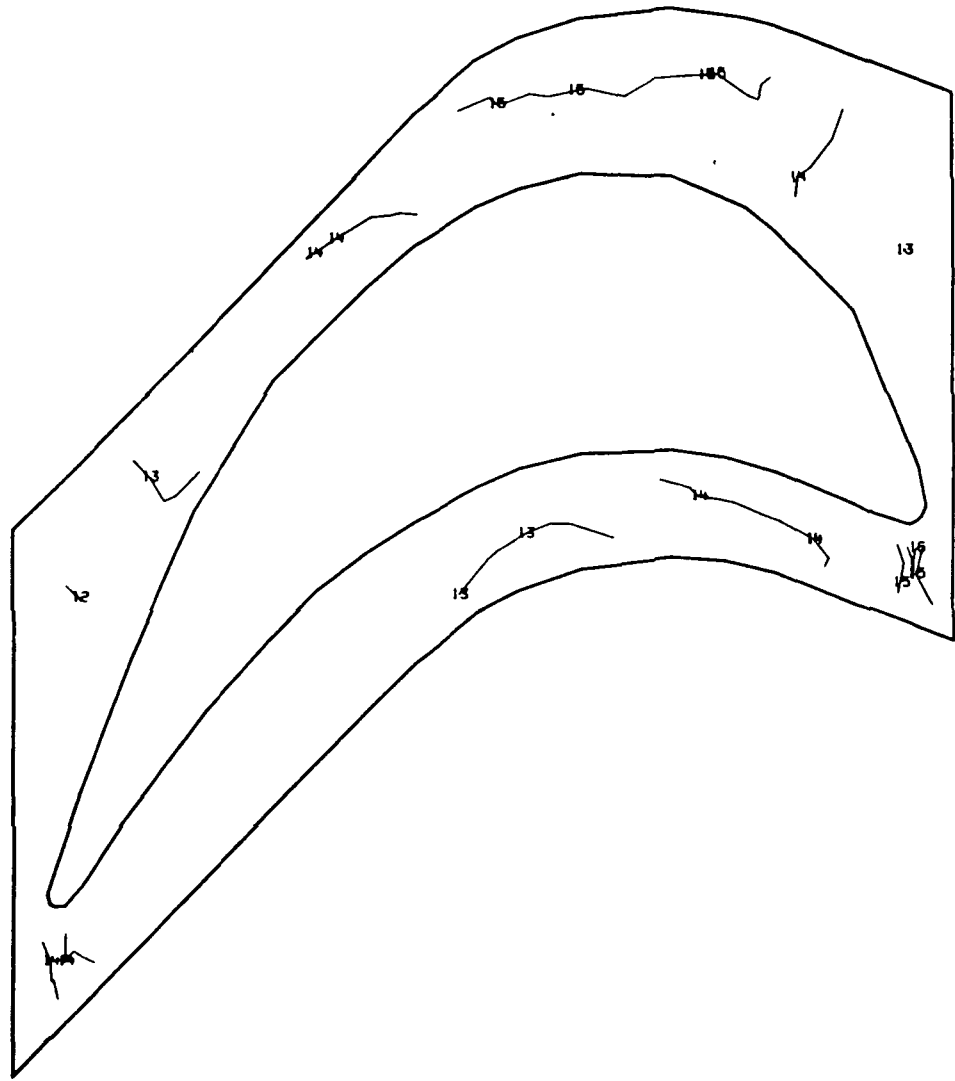

1	-1.500000E 05	12	-4.000000E 04	23	5.000000E 04
2	-1.400000E 05	13	-3.000000E 04	24	6.000000E 04
3	-1.300000E 05	14	-2.000000E 04	25	7.000000E 04
4	-1.200000E 05	15	-1.000000E 04	26	8.000000E 04
5	-1.100000E 05	16	-5.000000E 03	27	9.000000E 04
6	-1.000000E 05	17	0.0	28	1.000000E 05
7	-9.000000E 04	18	5.000000E 03	29	1.100000E 05
8	-8.000000E 04	19	1.000000E 04	30	1.200000E 05
9	-7.000000E 04	20	2.000000E 04	31	1.300000E 05
10	-6.000000E 04	21	3.000000E 04	32	1.400000E 05
11	-5.000000E 04	22	4.000000E 04	33	1.500000E 05

Fig. 2.5-54 Model 0-2, FPL Load, View 3, Platform Top
Minor Principal Stress (psi)

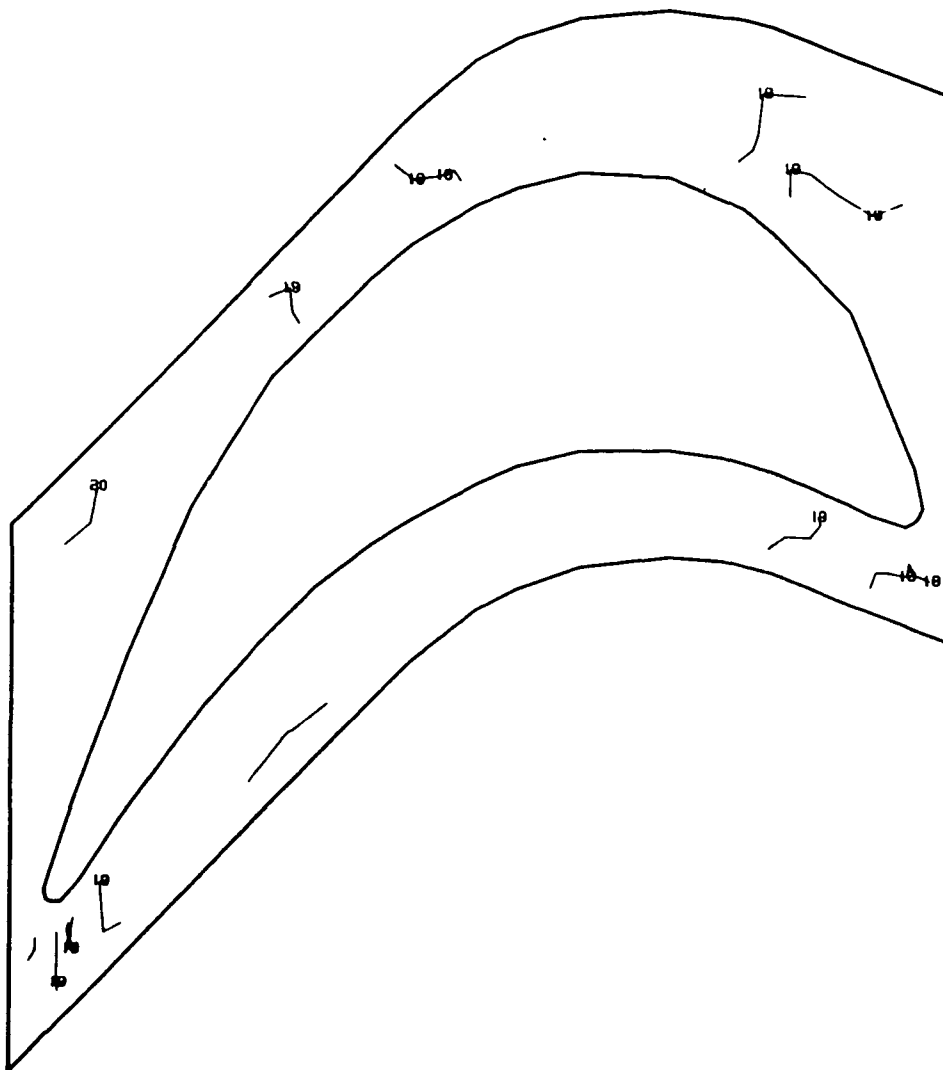

1	-1.500000E 05	12	-4.000000E 04	23	5.000000E 04
2	-1.400000E 05	13	-3.000000E 04	24	6.000000E 04
3	-1.300000E 05	14	-2.000000E 04	25	7.000000E 04
4	-1.200000E 05	15	-1.000000E 04	26	8.000000E 04
5	-1.100000E 05	16	-5.000000E 03	27	9.000000E 04
6	-1.000000E 05	17	0.0	28	1.000000E 05
7	-9.000000E 04	18	5.000000E 03	29	1.100000E 05
8	-8.000000E 04	19	1.000000E 04	30	1.200000E 05
9	-7.000000E 04	20	2.000000E 04	31	1.300000E 05
10	-6.000000E 04	21	3.000000E 04	32	1.400000E 05
11	-5.000000E 04	22	4.000000E 04	33	1.500000E 05

Fig. 2.5-55 Model 0-2, FPL Load, View 3, Platform Top
Maximum Principal Shear (psi)

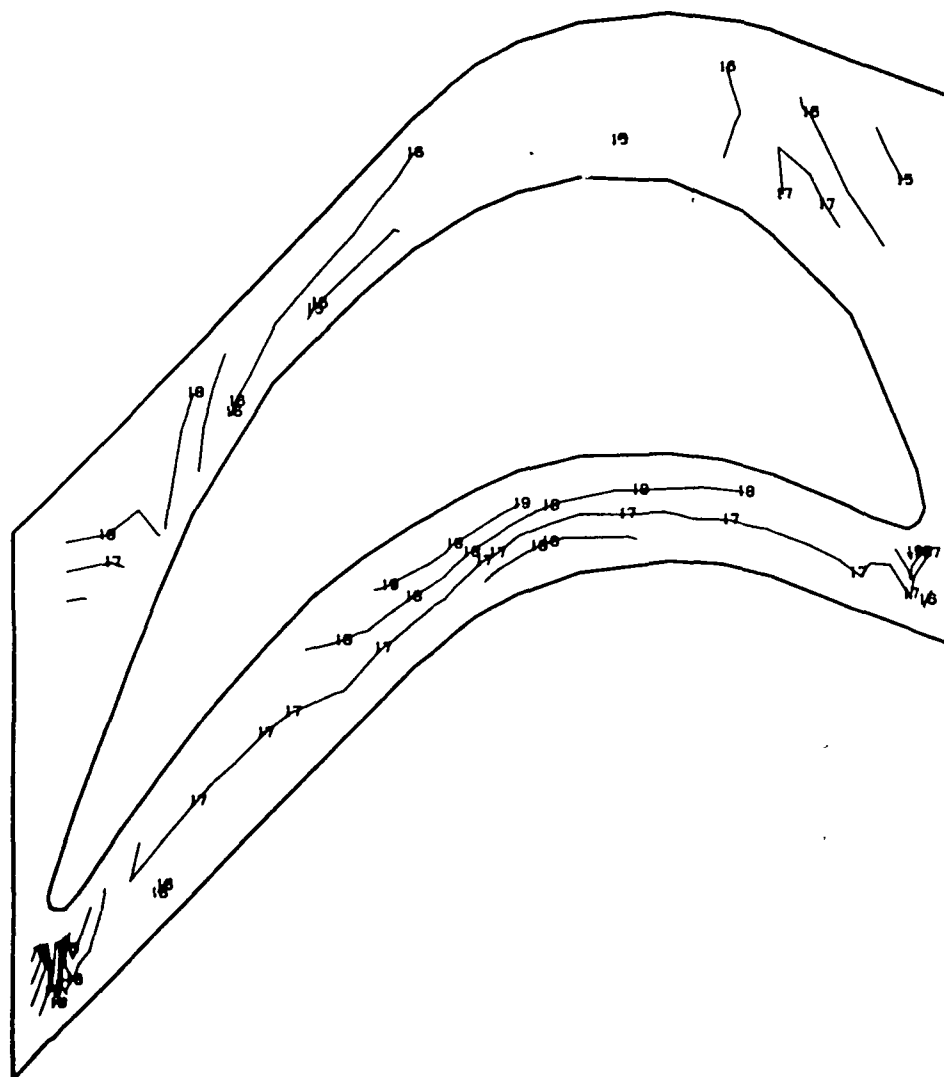

1	-1.500000E 05	12	-4.000000E 04	23	5.000000E 04
2	-1.400000E 05	13	-3.000000E 04	24	6.000000E 04
3	-1.300000E 05	14	-2.000000E 04	25	7.000000E 04
4	-1.200000E 05	15	-1.000000E 04	26	8.000000E 04
5	-1.100000E 05	16	-5.000000E 03	27	9.000000E 04
6	-1.000000E 05	17	0.0	28	1.000000E 05
7	-9.000000E 04	18	5.000000E 03	29	1.100000E 05
8	-8.000000E 04	19	1.000000E 04	30	1.200000E 05
9	-7.000000E 04	20	2.000000E 04	31	1.300000E 05
10	-6.000000E 04	21	3.000000E 04	32	1.400000E 05
11	-5.000000E 04	22	4.000000E 04	33	1.500000E 05

Fig. 2.5-56 Model 0-2, 115% Load, View 3, Platform Top Major Principal Stress (psi)

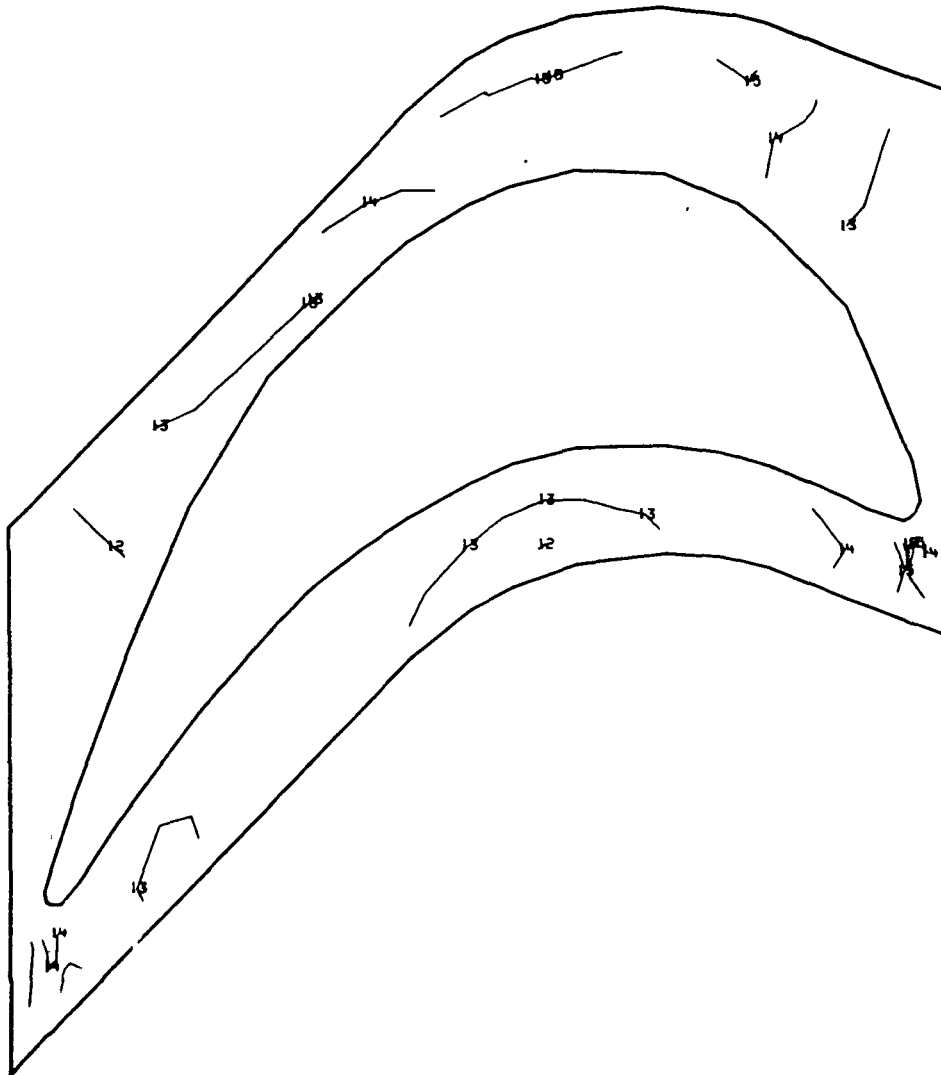

1	-1.500000E 05	12	-4.000000E 04	23	5.000000E 04
2	-1.400000E 05	13	-3.000000E 04	24	6.000000E 04
3	-1.300000E 05	14	-2.000000E 04	25	7.000000E 04
4	-1.200000E 05	15	-1.000000E 04	26	8.000000E 04
5	-1.100000E 05	16	-5.000000E 03	27	9.000000E 04
6	-1.000000E 05	17	0.0	28	1.000000E 05
7	-9.000000E 04	18	5.000000E 03	29	1.100000E 05
8	-8.000000E 04	19	1.000000E 04	30	1.200000E 05
9	-7.000000E 04	20	2.000000E 04	31	1.300000E 05
10	-6.000000E 04	21	3.000000E 04	32	1.400000E 05
11	-5.000000E 04	22	4.000000E 04	33	1.500000E 05

Fig. 2.5-57 Model 0-2, 115% Load, View 3, Platform Top
Minor Principal Stress (psi)

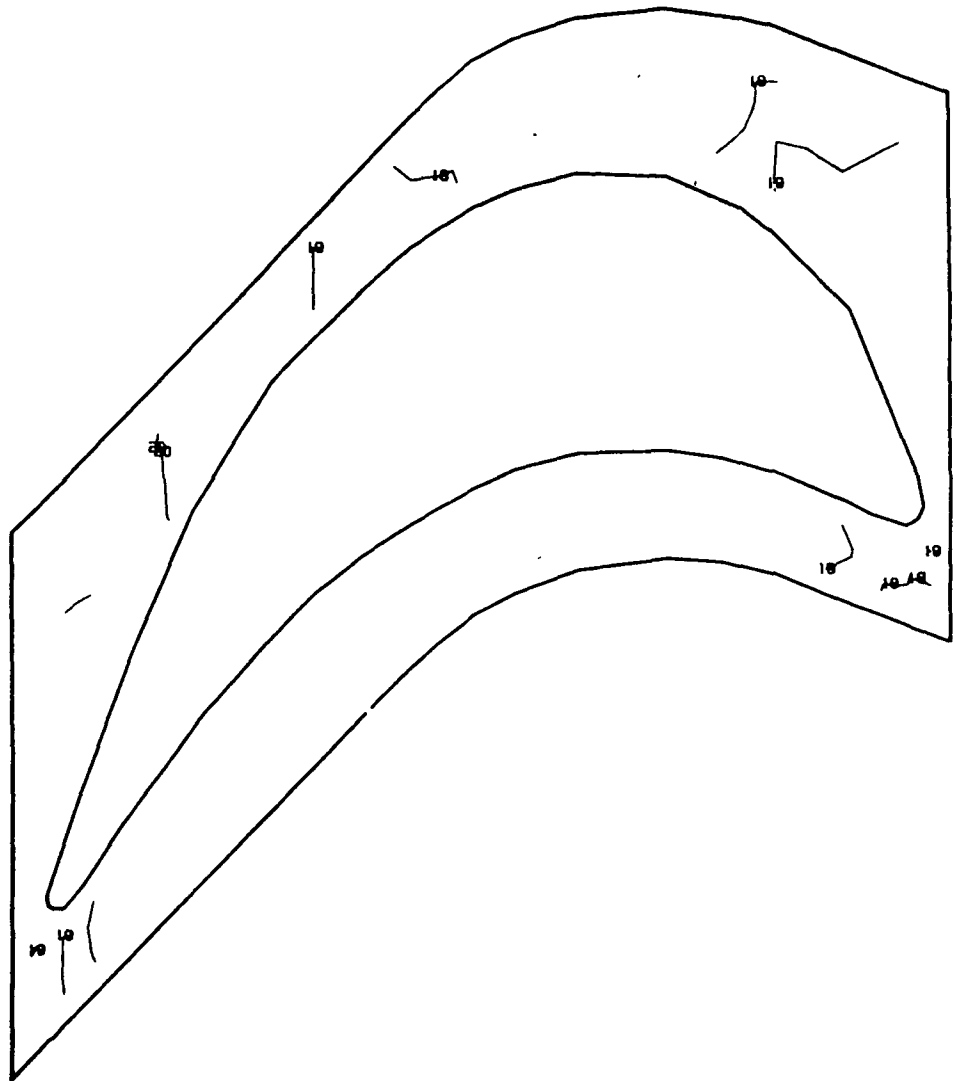

1	-1.500000E 05	12	-4.000000E 04	23	5.000000E 04
2	-1.400000E 05	13	-3.000000E 04	24	6.000000E 04
3	-1.300000E 05	14	-2.000000E 04	25	7.000000E 04
4	-1.200000E 05	15	-1.000000E 04	26	8.000000E 04
5	-1.100000E 05	16	-5.000000E 03	27	9.000000E 04
6	-1.000000E 05	17	0.0	28	1.000000E 05
7	-9.000000E 04	18	5.000000E 03	29	1.100000E 05
8	-8.000000E 04	19	1.000000E 04	30	1.200000E 05
9	-7.000000E 04	20	2.000000E 04	31	1.300000E 05
10	-6.000000E 04	21	3.000000E 04	32	1.400000E 05
11	-5.000000E 04	22	4.000000E 04	33	1.500000E 05

Fig. 2.5-58 Model 0-2, 115% Load, View 3, Platform Top
Maximum Principal Shear (psi)

2.5-58

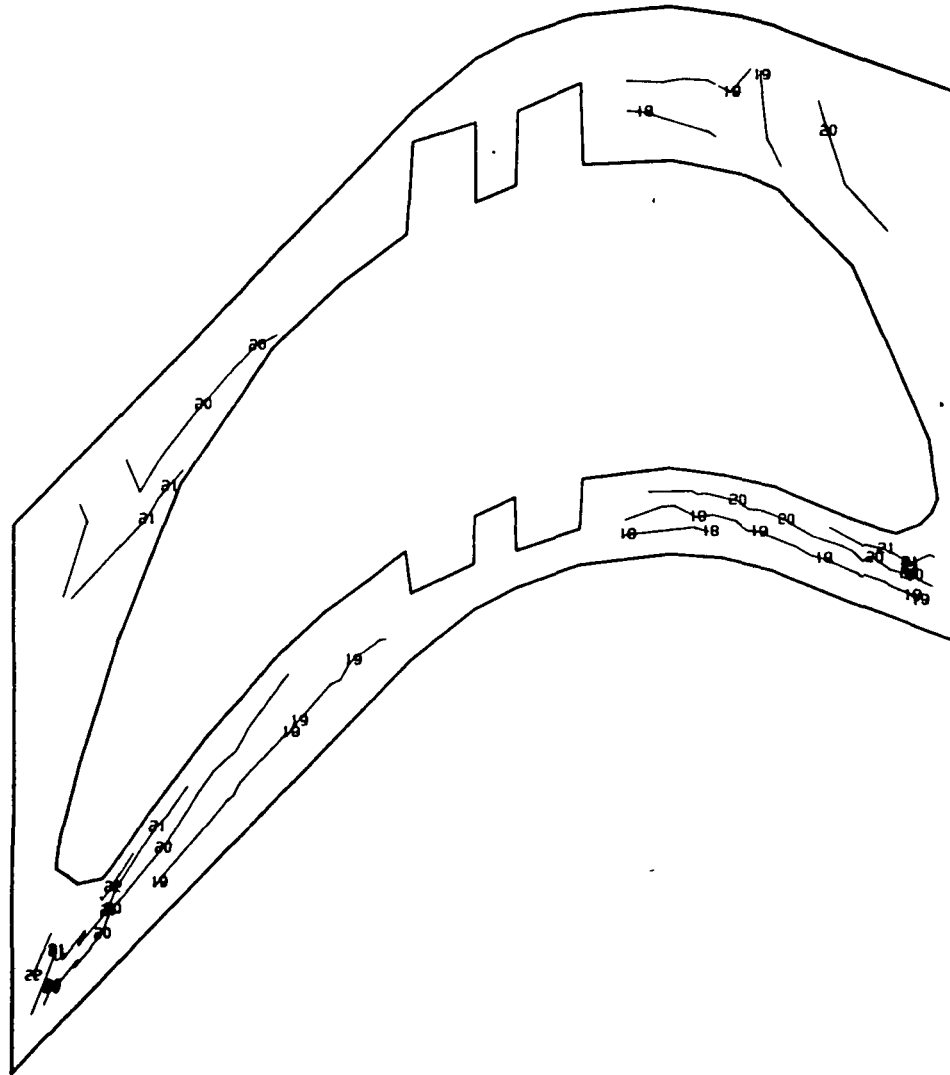

1	-1.500000E 05	12	-4.000000E 04	23	5.000000E 04
2	-1.400000E 05	13	-3.000000E 04	24	6.000000E 04
3	-1.300000E 05	14	-2.000000E 04	25	7.000000E 04
4	-1.200000E 05	15	-1.000000E 04	26	8.000000E 04
5	-1.100000E 05	16	-5.000000E 03	27	9.000000E 04
6	-1.000000E 05	17	0.0	28	1.000000E 05
7	-9.000000E 04	18	5.000000E 03	29	1.100000E 05
8	-8.000000E 04	19	1.000000E 04	30	1.200000E 05
9	-7.000000E 04	20	2.000000E 04	31	1.300000E 05
10	-6.000000E 04	21	3.000000E 04	32	1.400000E 05
11	-5.000000E 04	22	4.000000E 04	33	1.500000E 05

Fig. 2.5-59 Model 0-2, FPL Load, View 3, Platform Bottom
Major Principal Stress (psi)

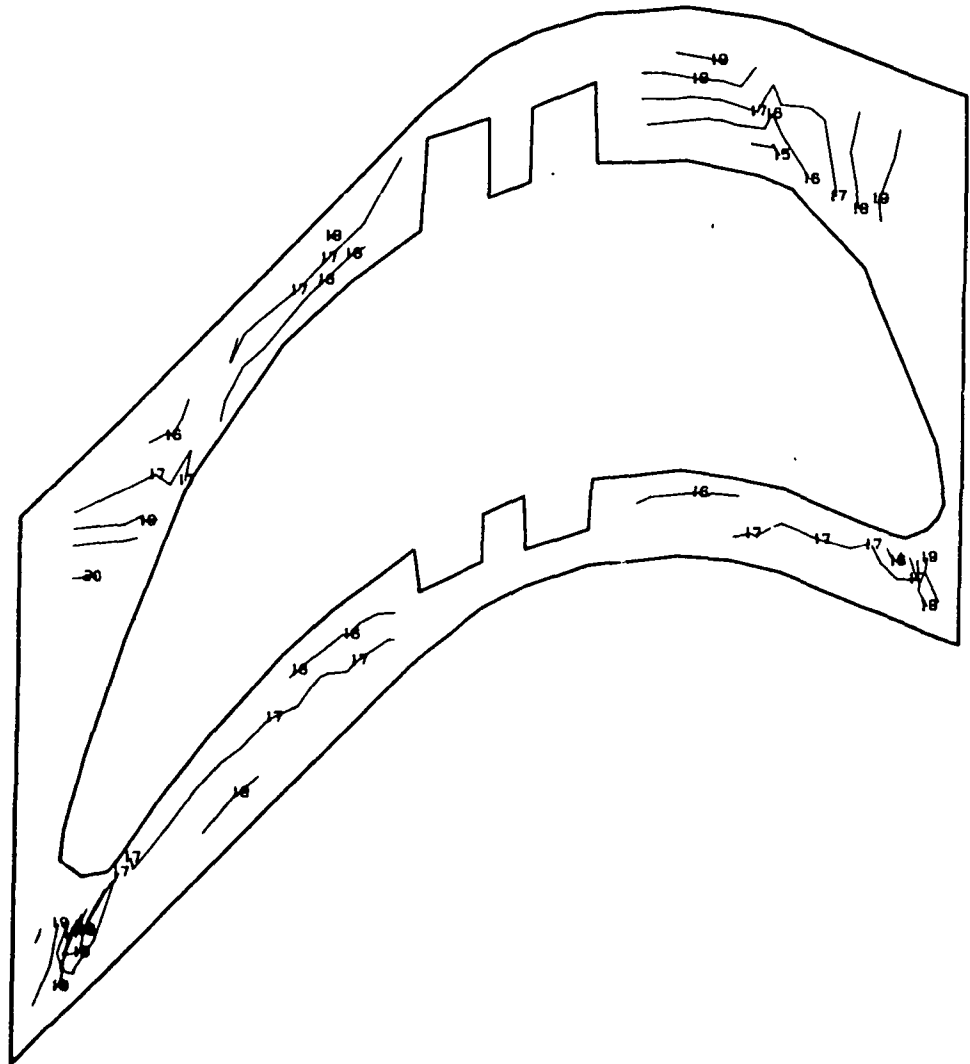

1	-1.500000E 05	12	-4.000000E 04	23	5.000000E 04
2	-1.400000E 05	13	-3.000000E 04	24	6.000000E 04
3	-1.300000E 05	14	-2.000000E 04	25	7.000000E 04
4	-1.200000E 05	15	-1.000000E 04	26	8.000000E 04
5	-1.100000E 05	16	-5.000000E 03	27	9.000000E 04
6	-1.000000E 05	17	0.0	28	1.000000E 05
7	-9.000000E 04	18	5.000000E 03	29	1.100000E 05
8	-8.000000E 04	19	1.000000E 04	30	1.200000E 05
9	-7.000000E 04	20	2.000000E 04	31	1.300000E 05
10	-6.000000E 04	21	3.000000E 04	32	1.400000E 05
11	-5.000000E 04	22	4.000000E 04	33	1.500000E 05

Fig. 2.5-60 Model 0-2, FPL Load, View 3, Platform Bottom
Minor Principal Stress (psi)

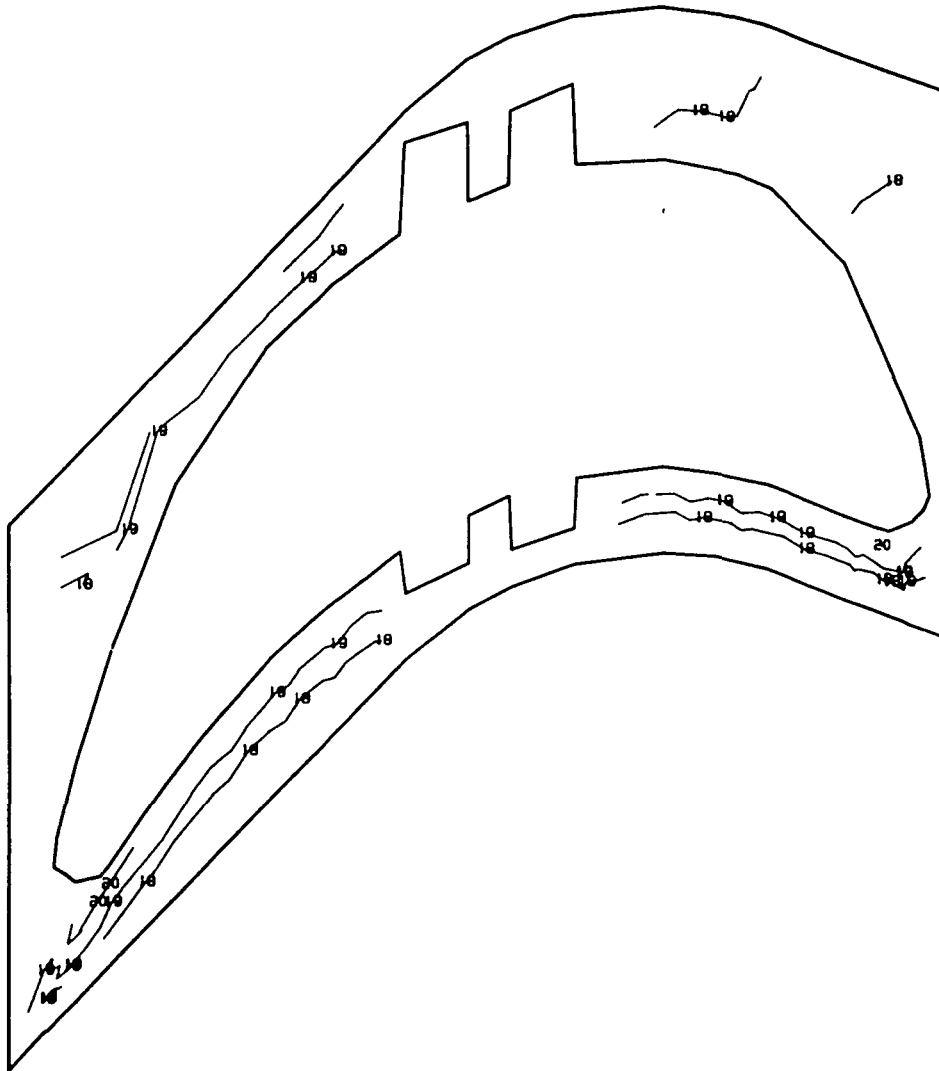

1	-1.500000E 05	12	-4.000000E 04	23	5.000000E 04
2	-1.400000E 05	13	-3.000000E 04	24	6.000000E 04
3	-1.300000E 05	14	-2.000000E 04	25	7.000000E 04
4	-1.200000E 05	15	-1.000000E 04	26	8.000000E 04
5	-1.100000E 05	16	-5.000000E 03	27	9.000000E 04
6	-1.000000E 05	17	0.0	28	1.000000E 05
7	-9.000000E 04	18	5.000000E 03	29	1.100000E 05
8	-8.000000E 04	19	1.000000E 04	30	1.200000E 05
9	-7.000000E 04	20	2.000000E 04	31	1.300000E 05
10	-6.000000E 04	21	3.000000E 04	32	1.400000E 05
11	-5.000000E 04	22	4.000000E 04	33	1.500000E 05

Fig. 2.5-61 Model 0-2, FPL Load, View 3, Platform Bottom
Maximum Principal Shear (psi)

2.5-61

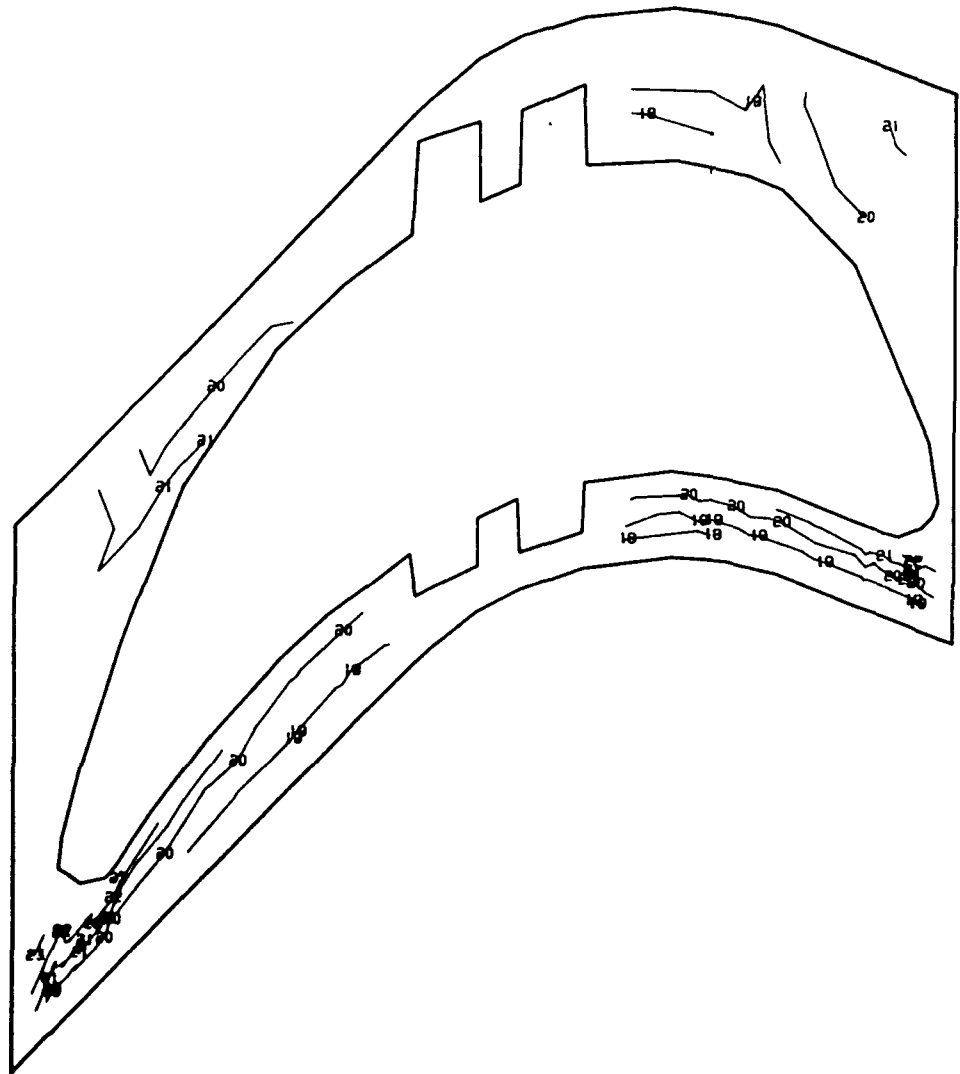

1	-1.500000E 05	12	-4.000000E 04	23	5.000000E 04
2	-1.400000E 05	13	-3.000000E 04	24	6.000000E 04
3	-1.300000E 05	14	-2.000000E 04	25	7.000000E 04
4	-1.200000E 05	15	-1.000000E 04	26	8.000000E 04
5	-1.100000E 05	16	-5.000000E 03	27	9.000000E 04
6	-1.000000E 05	17	0.0	28	1.000000E 05
7	-9.000000E 04	18	5.000000E 03	29	1.100000E 05
8	-8.000000E 04	19	1.000000E 04	30	1.200000E 05
9	-7.000000E 04	20	2.000000E 04	31	1.300000E 05
10	-6.000000E 04	21	3.000000E 04	32	1.400000E 05
11	-5.000000E 04	22	4.000000E 04	33	1.500000E 05

Fig. 2.5-62 Model 0-2, 115% Load, View 3, Platform Bottom Major Principal Stress (psi)

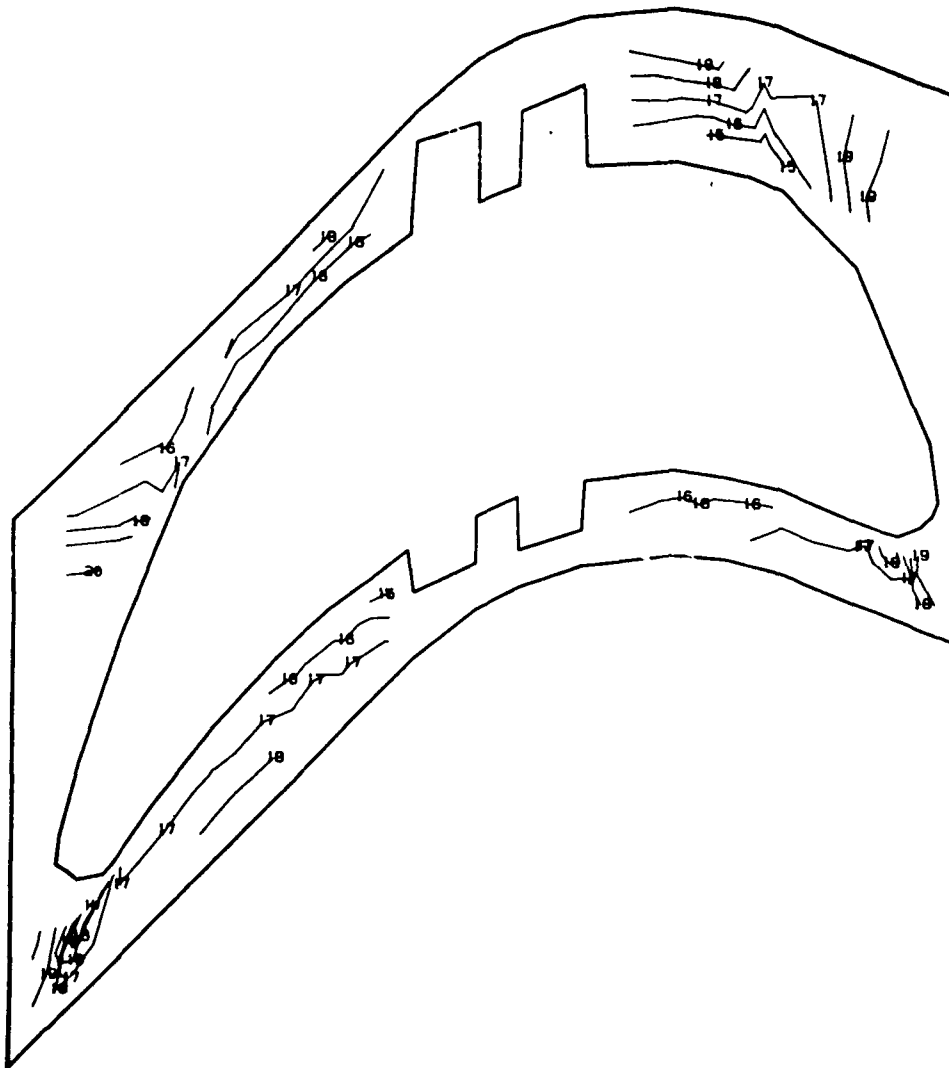

1	-1.500000E 05	12	-4.000000E 04	23	5.000000E 04
2	-1.400000E 05	13	-3.000000E 04	24	6.000000E 04
3	-1.300000E 05	14	-2.000000E 04	25	7.000000E 04
4	-1.200000E 05	15	-1.000000E 04	26	8.000000E 04
5	-1.100000E 05	16	-5.000000E 03	27	9.000000E 04
6	-1.000000E 05	17	0.0	28	1.000000E 05
7	-9.000000E 04	18	5.000000E 03	29	1.100000E 05
8	-8.000000E 04	19	1.000000E 04	30	1.200000E 05
9	-7.000000E 04	20	2.000000E 04	31	1.300000E 05
10	-6.000000E 04	21	3.000000E 04	32	1.400000E 05
11	-5.000000E 04	22	4.000000E 04	33	1.500000E 05

Fig. 2.5-63 Model 0-2, 115% Load, View 3, Platform Bottom
Minor Principal Stress (psi)

2.5-63

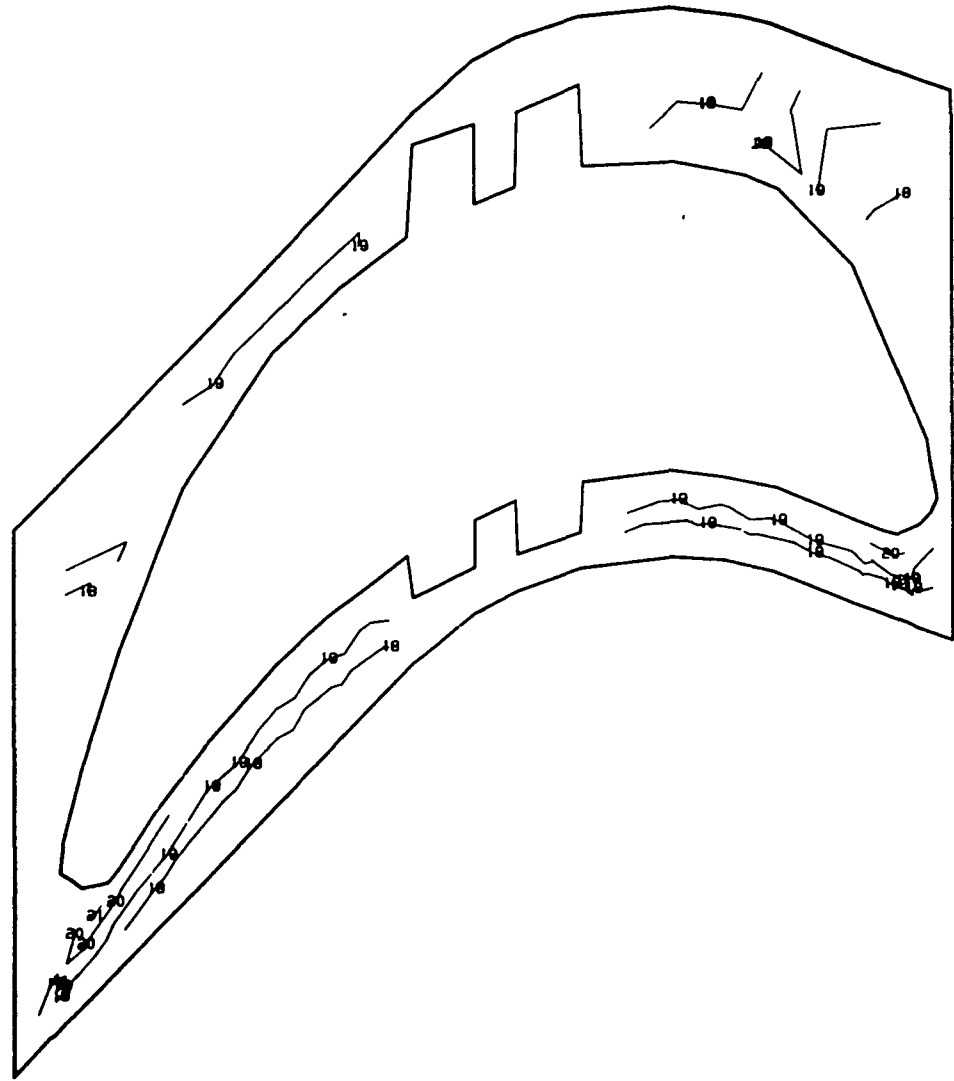

1	-1.500000E 05	12	-4.000000E 04	23	5.000000E 04
2	-1.400000E 05	13	-3.000000E 04	24	6.000000E 04
3	-1.300000E 05	14	-2.000000E 04	25	7.000000E 04
4	-1.200000E 05	15	-1.000000E 04	26	8.000000E 04
5	-1.100000E 05	16	-5.000000E 03	27	9.000000E 04
6	-1.000000E 05	17	0.0	28	1.000000E 05
7	-9.000000E 04	18	5.000000E 03	29	1.100000E 05
8	-8.000000E 04	19	1.000000E 04	30	1.200000E 05
9	-7.000000E 04	20	2.000000E 04	31	1.300000E 05
10	-6.000000E 04	21	3.000000E 04	32	1.400000E 05
11	-5.000000E 04	22	4.000000E 04	33	1.500000E 05

Fig. 2.5-64 Model O-2, 115% Load, View 3, Platform Bottom
Maximum Principal Shear (psi)

PART II

3. SSME TURBOPUMP NOZZLES

Section 3.1 describes the computer models used for the analysis and provides a guide for the reader in following the subsequent results in Sections 3.2 through 3.5.

3.1 SSME NOZZLES - MODEL DESCRIPTION

Four NASTRAN nozzle models were made to simulate airfoil blade segments of the first and second stage HPFTP (F1 and F2 models) and first and second stage HPOTP (O1 and O2 models). The general approach to all four models is the same. Figure 3.1-1 shows a typical complete nozzle casting.

The grids are defined in rectangular coordinate systems with the Z axis radially outward and with the X axis in the direction of gas flow. The exception is model F2 which has the Y axis in the direction of gas flow. The displacement coordinate system is cylindrical. Figure 3.1-2 presents the typical coordinate system arrangement. Figure 3.1-3 gives the model F2 coordinate system.

Boundary conditions applied to the modeled segments are as follows: constraints on rigid body movement of the whole assembly are placed on the casting support points as shown in Fig. 3.1-4. Constraints are also made on each point of one cut surface such that it translates equally with its corresponding point on the opposite cut surface. This ensures that the segment acts symmetrically with its implied adjacent segments (see Fig. 3.1-5).

The four models are primarily CIHEX1 elements with CWEDGE and CTETRA elements as required. Grid and element ID number prefixes increase with

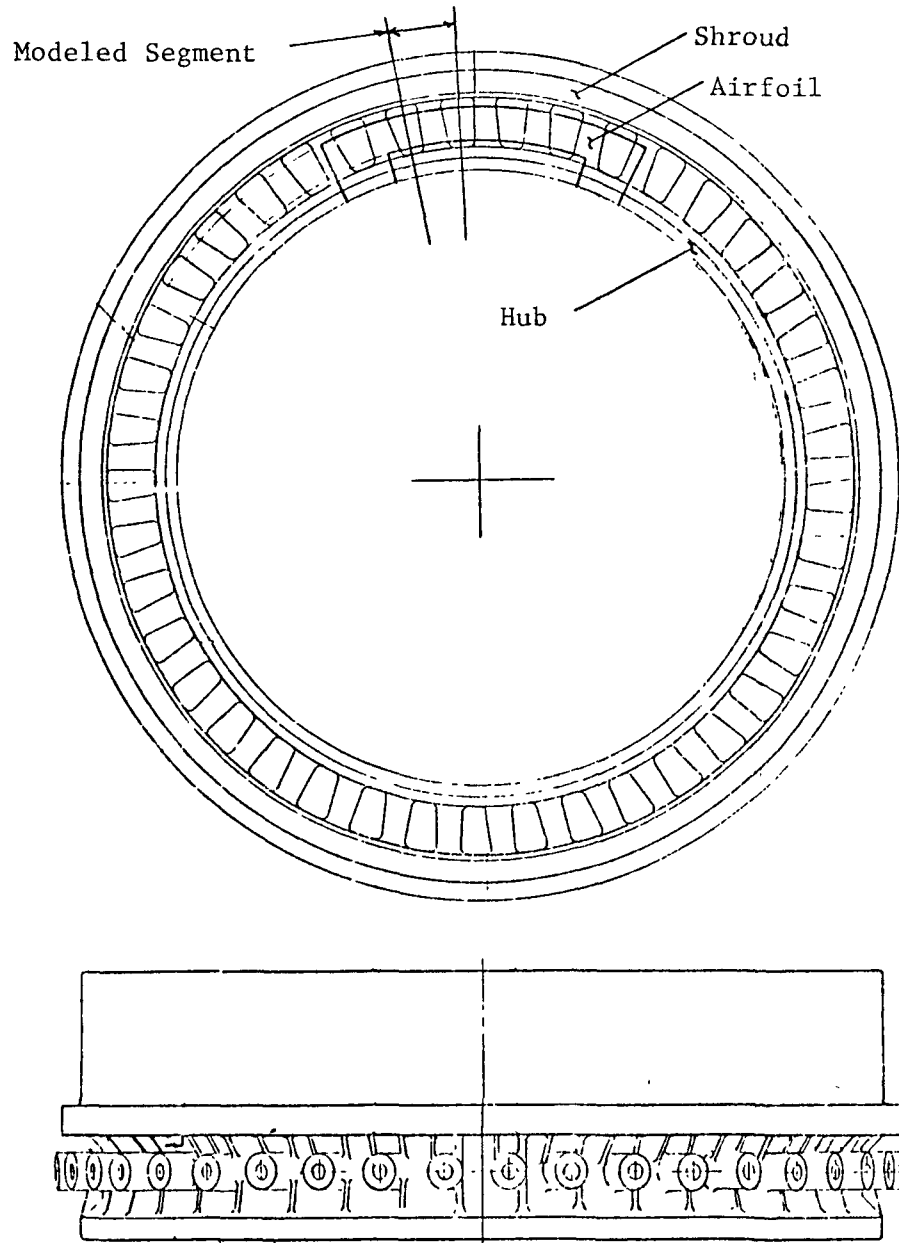

Fig. 3.1-1 Typical Nozzle Casting Showing Modeled Segment

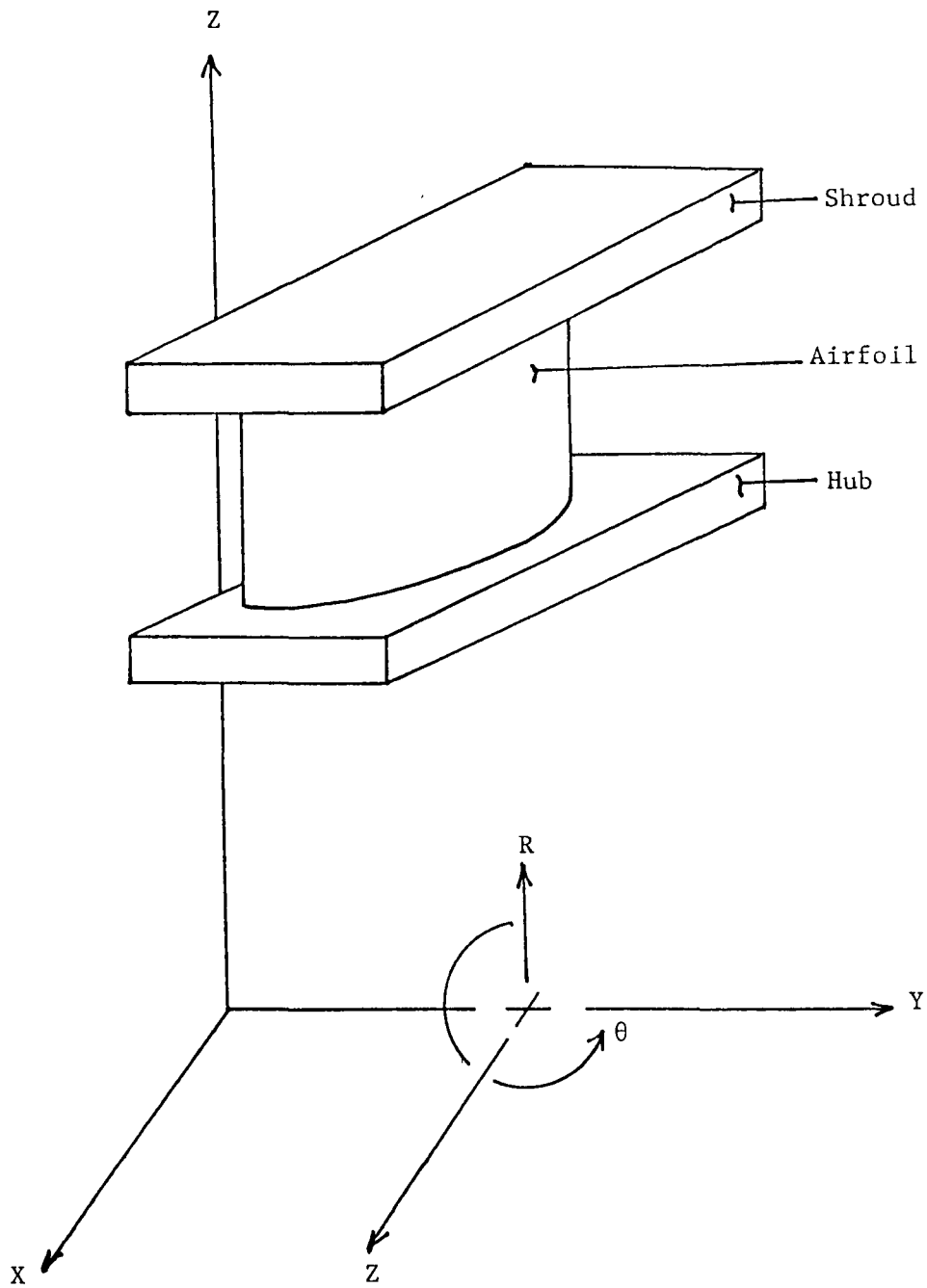

Fig. 3.1-2 Coordinate Systems for Models F1, O1, and O2

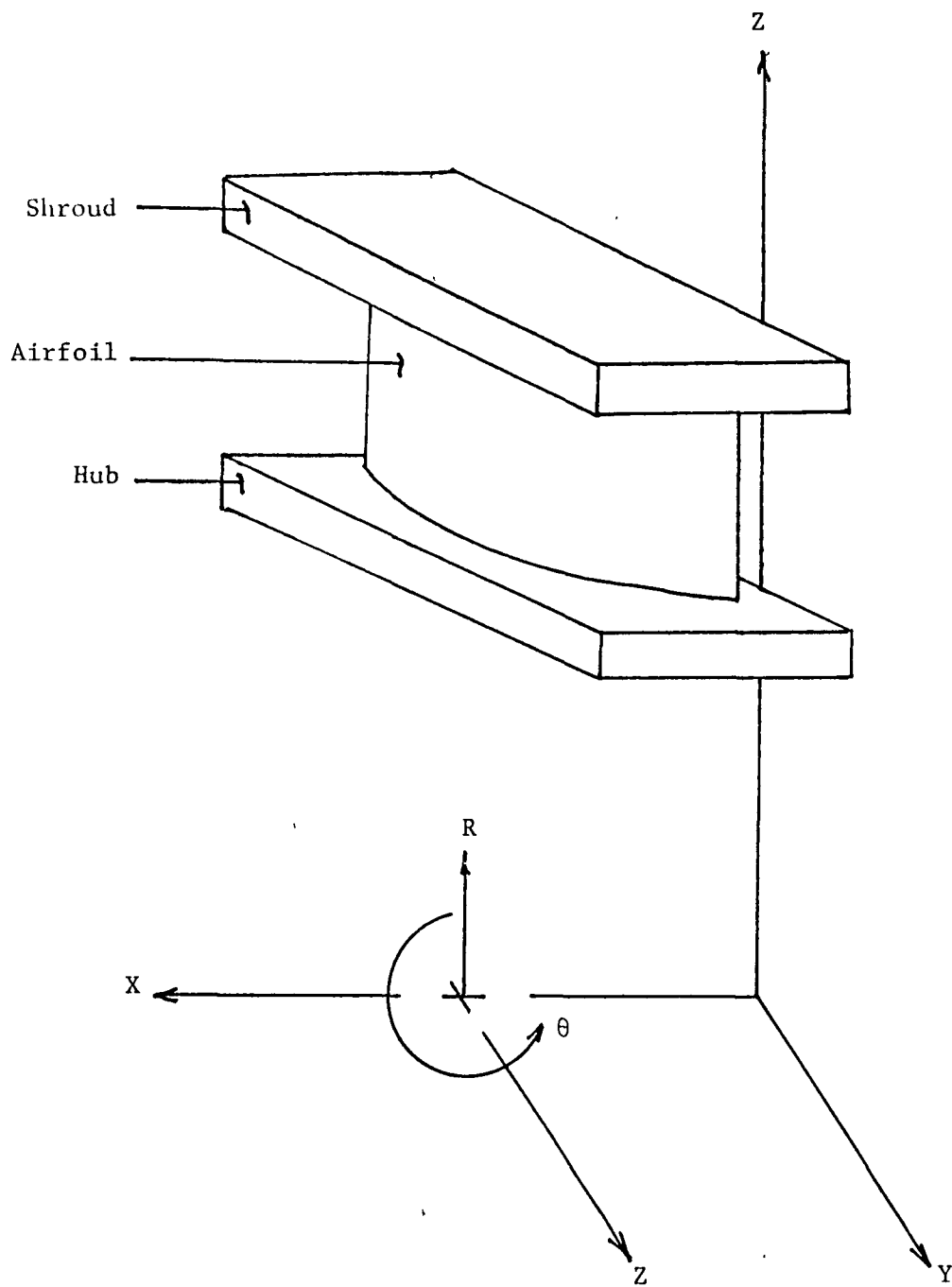

Fig. 3.1-3 Coordinate System for Model F2

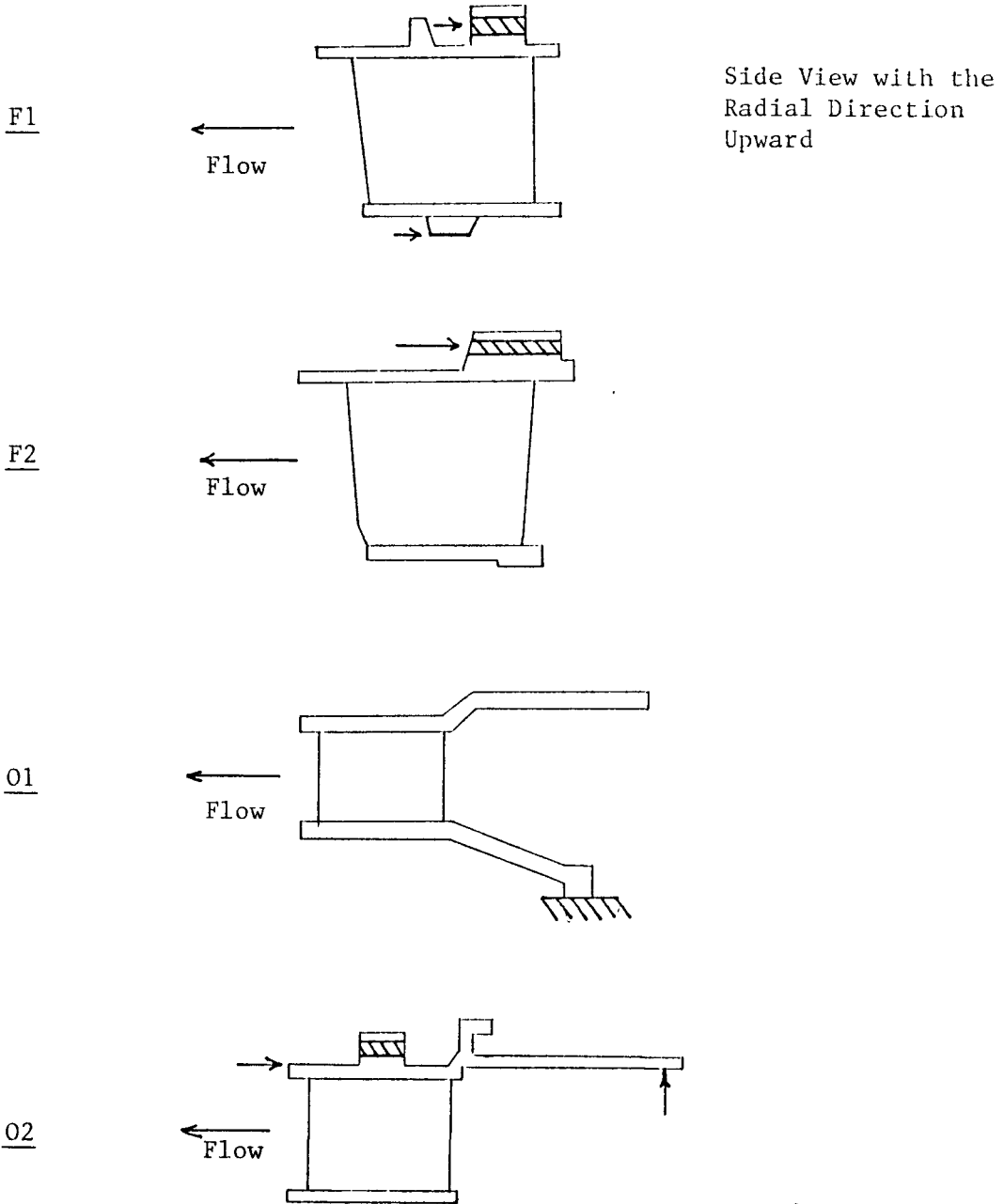
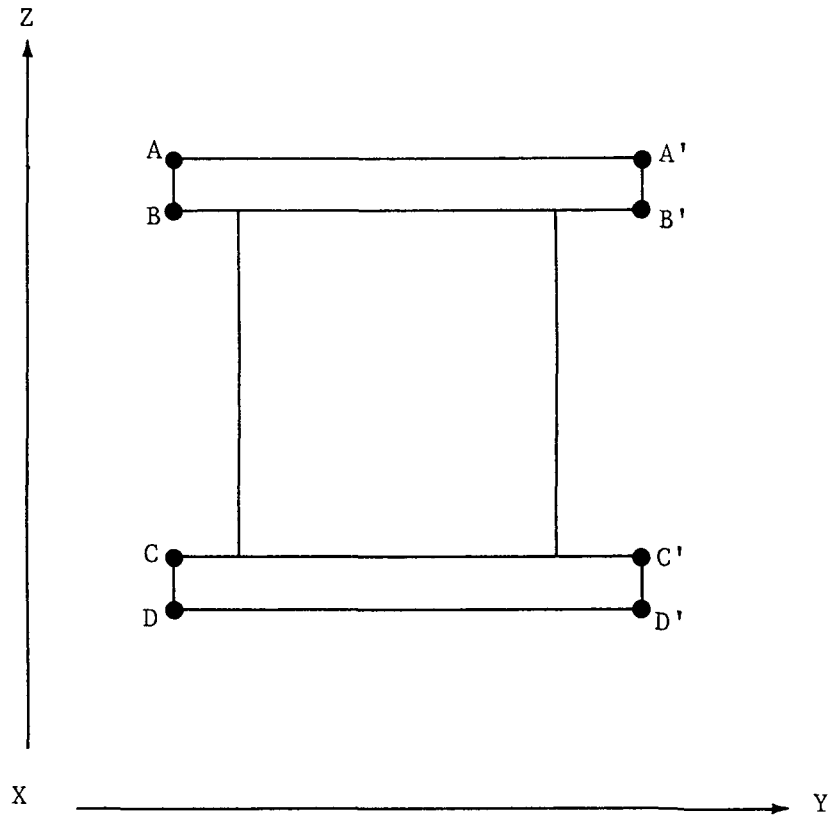

Fig. 3.1-4 Rigid Body Support Points



$$\begin{aligned}
 C_{AX} &= C_{A'X} & C_{BX} &= C_{B'} \\
 C_{AY} &= C_{A'Y} & C_{BY} &= C_{B'} \\
 C_{AZ} &= C_{A'Z} & C_{BZ} &= C_{B'}
 \end{aligned}$$

$$\begin{aligned}
 C_{CX} &= C_{C'X} & C_{DX} &= C_{D'} \\
 C_{CY} &= C_{C'Y} & C_{DY} &= C_{D'} \\
 C_{CZ} &= C_{C'Z} & C_{DZ} &= C_{D'}
 \end{aligned}$$

Fig. 3.1-5 Coupled Constraints Between Cut Surfaces

increasing radius in levels as shown in Figs. 3.1-6, 3.1-8, 3.1-10, and 3.1-12. Plots showing elements and grids at representative levels follow each figure given.

After the four models were executed for normal modes, a processor was run to generate very thin (1×10^{-6} in. thick) CQUAD1 elements over all exterior CIHEX surfaces. A second processor used the generated CQUAD1 grids of the airfoil portions of the models to interpolate thermal and pressure data from airfoil load source models. A third processor used the interpolated airfoil data with shroud and hub pressure data to generate the NASTRAN load input. Shroud and hub pressures are considered to vary linearly along the direction of flow as shown in Figs. 3.2-14 and 3.1-15.

The CQUAD1 elements are also required for contour stress plots. Principal stresses are plotted for each major surface and are presented in Sections 3.2 through 3.5 in the form of surface stress contour plots.

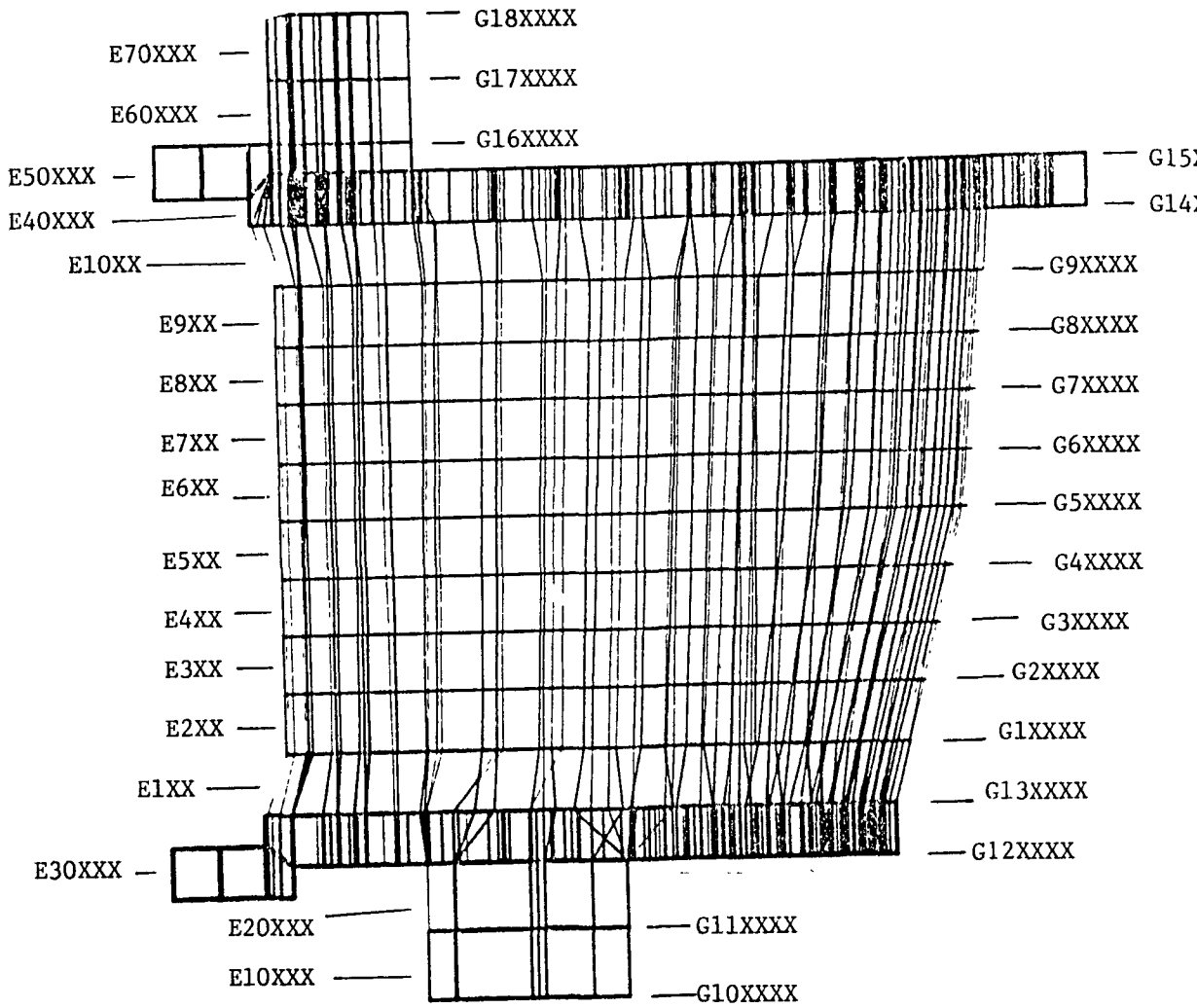

Fig. 3.1-6 Fl Model Element and Grid Prefixes

Fig. 3.1-6 Fl Model Element and Grid Prefixes

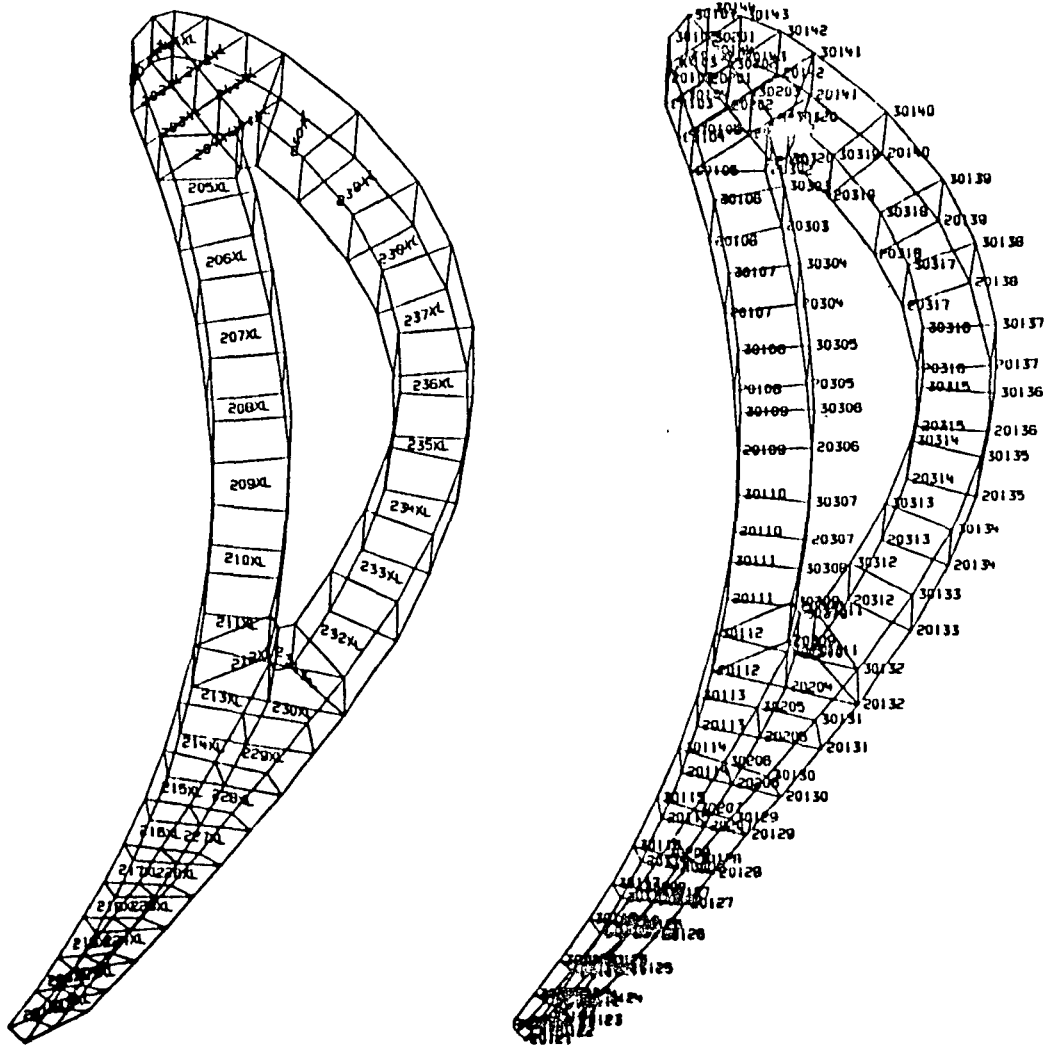

Fig. 3.1-7 F1 Model Representative Airfoil Section

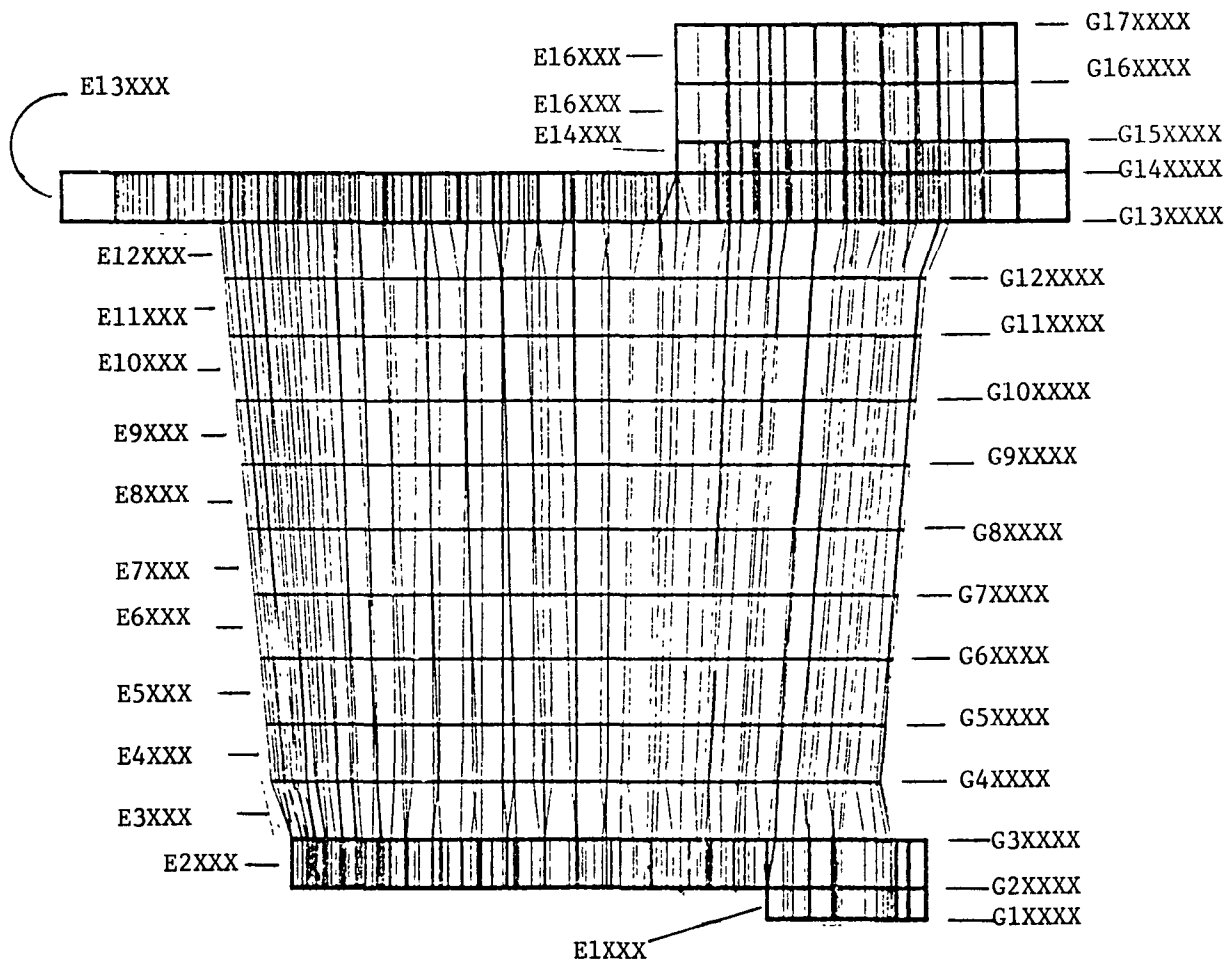

Fig. 3.1-8 F2 Model Element and Grid ID Prefixes

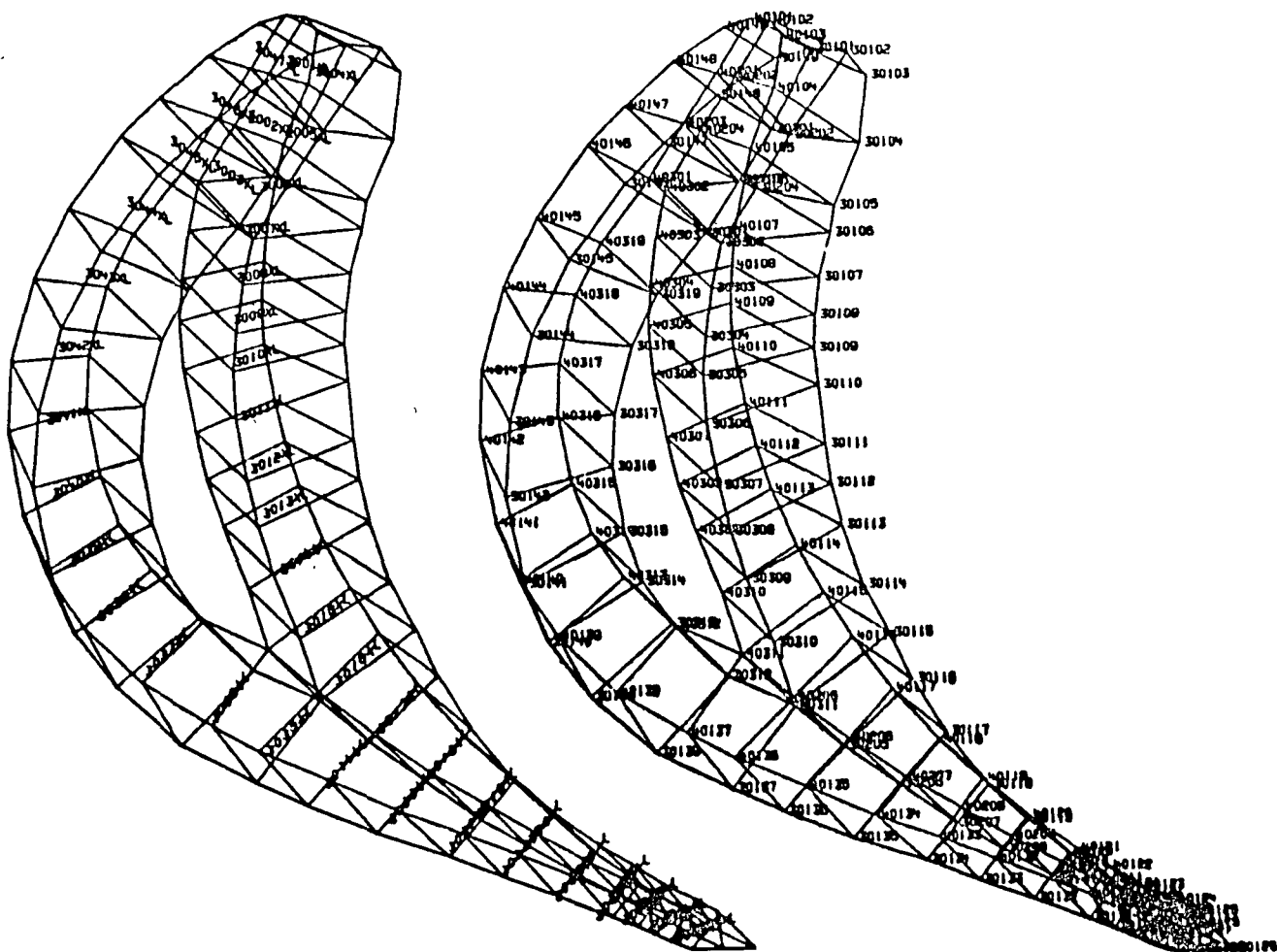

Fig. 3.1-9 F2 Model Representative Airfoil Section

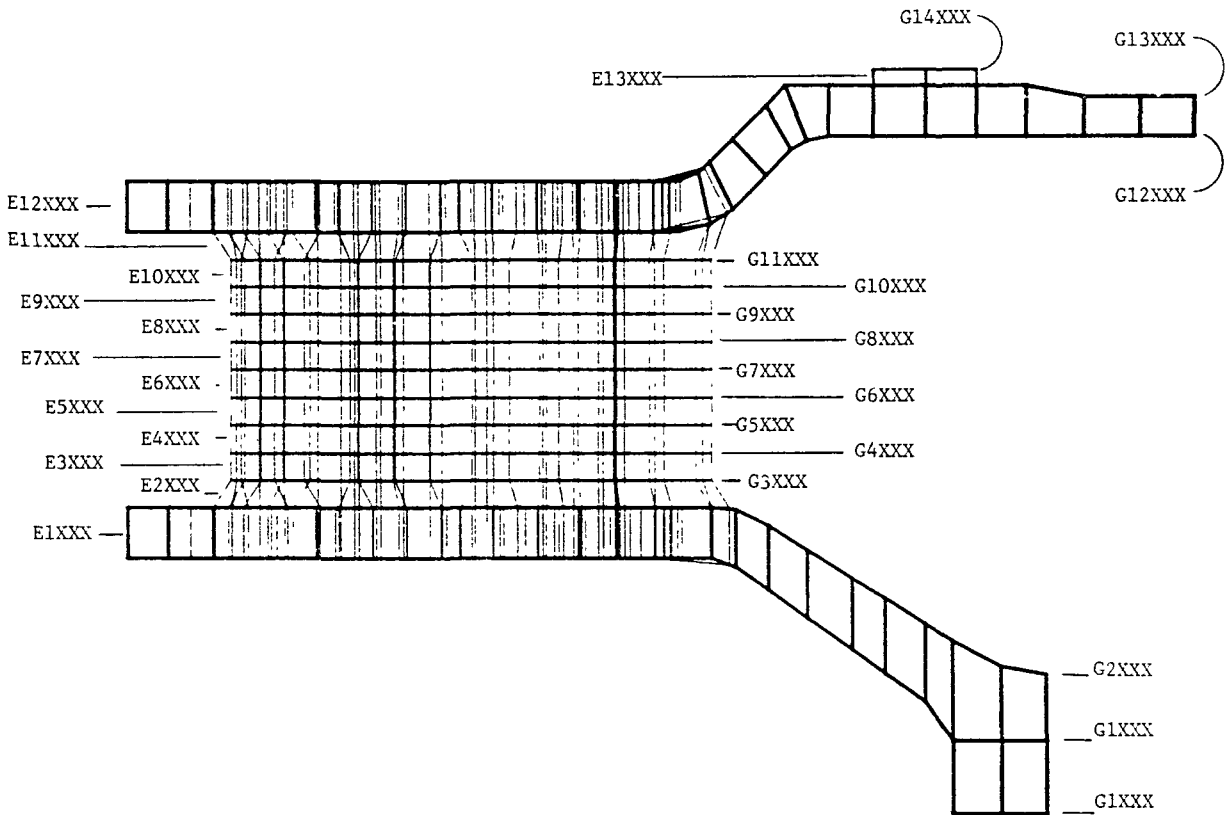

Fig. 3.1-10 01 Model Element and Grid Prefixes

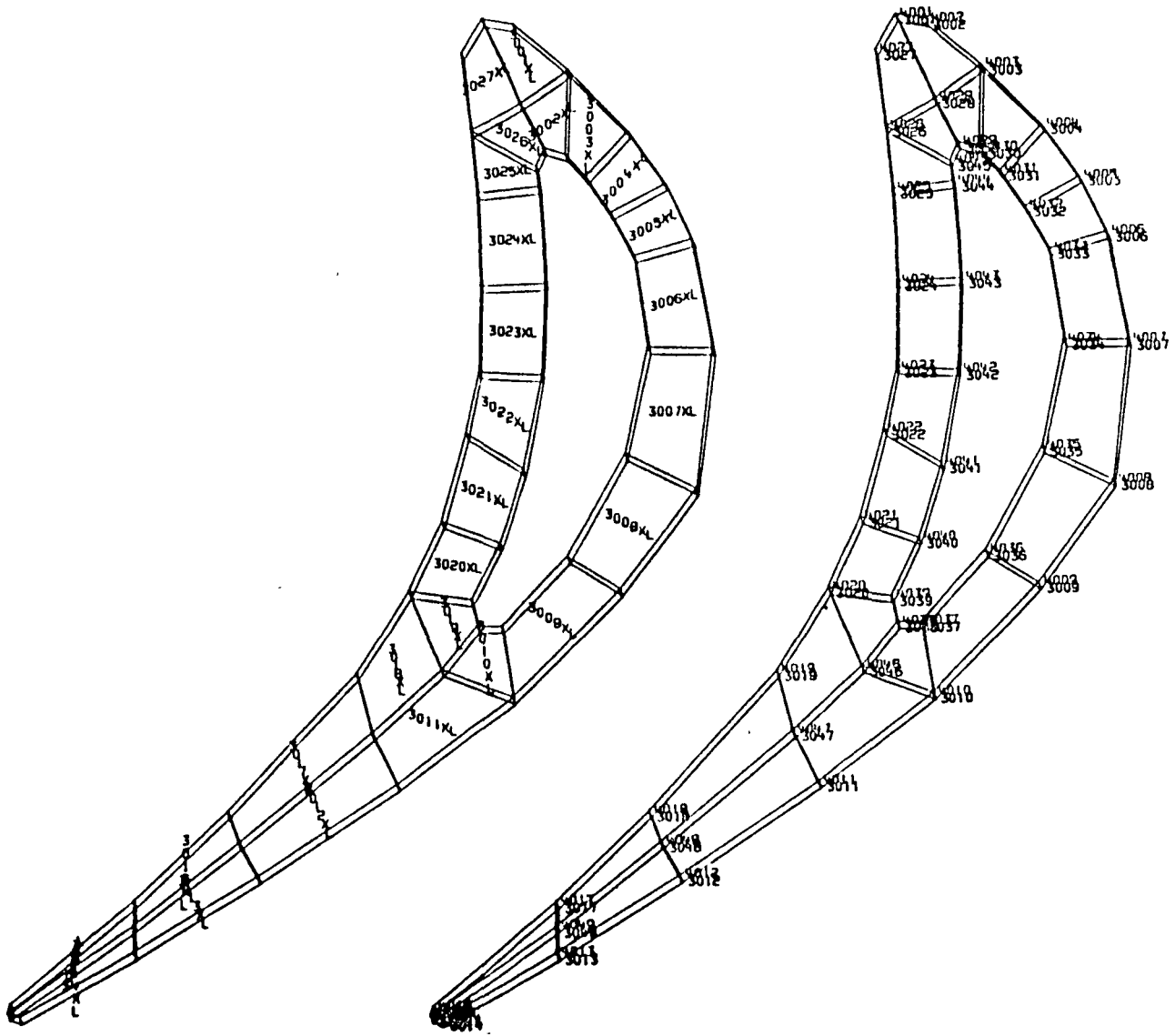

Fig. 3.1-11 01 Model Representative Section

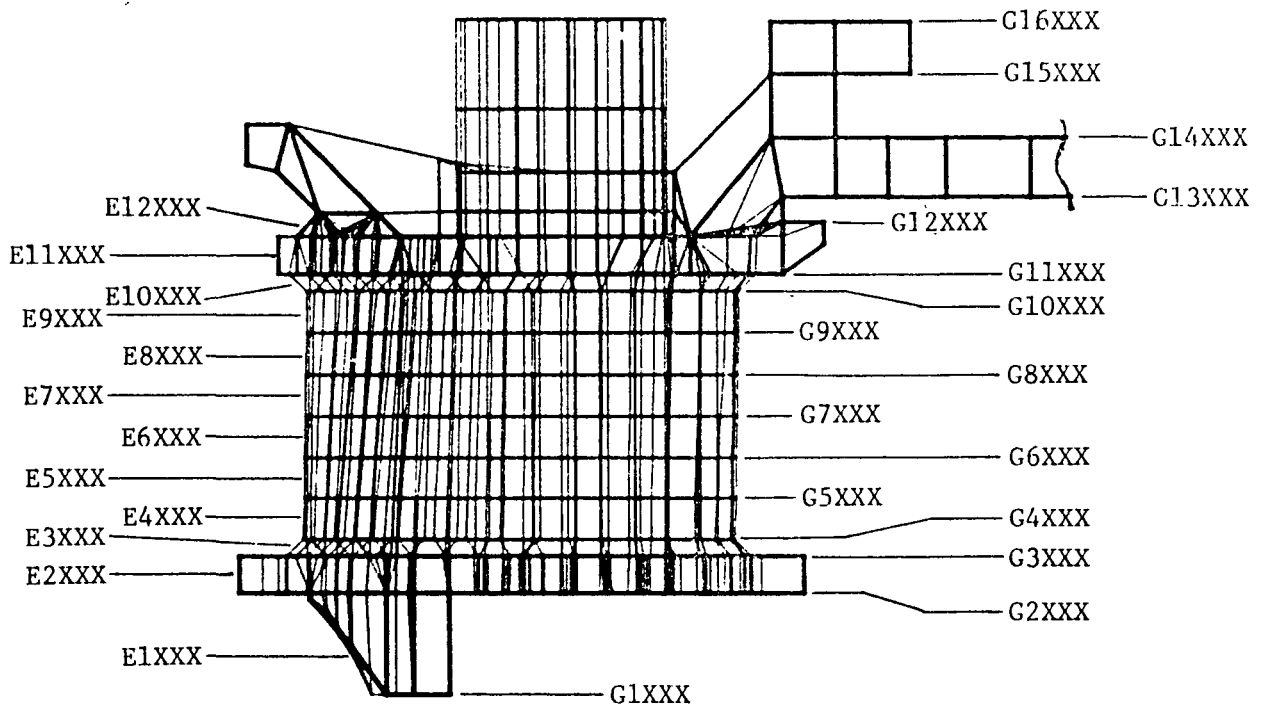

Fig. 3.1-12 02 Model Element and Grid Prefixes

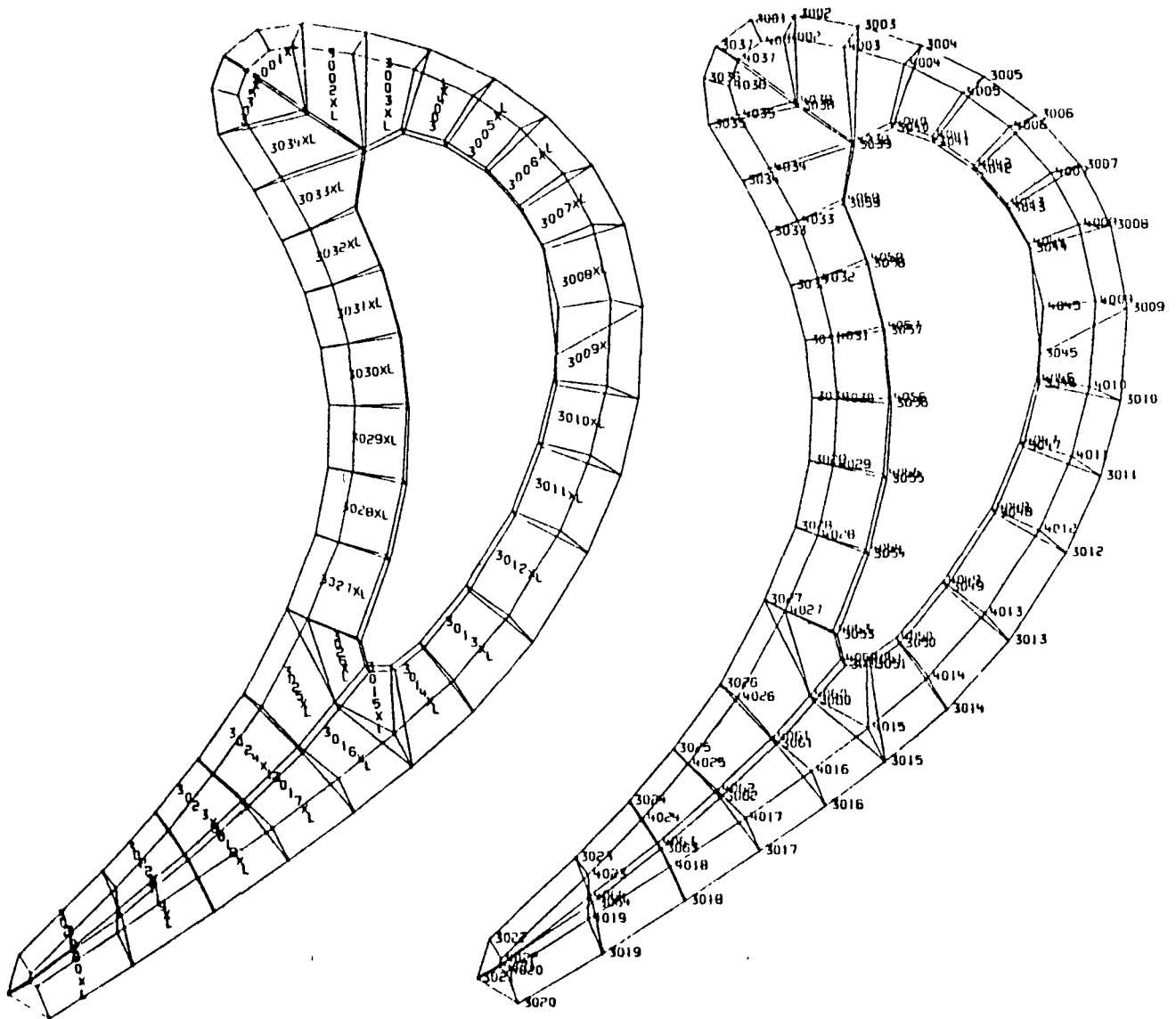

Fig. 3.1-13 O2 Model Representative Section

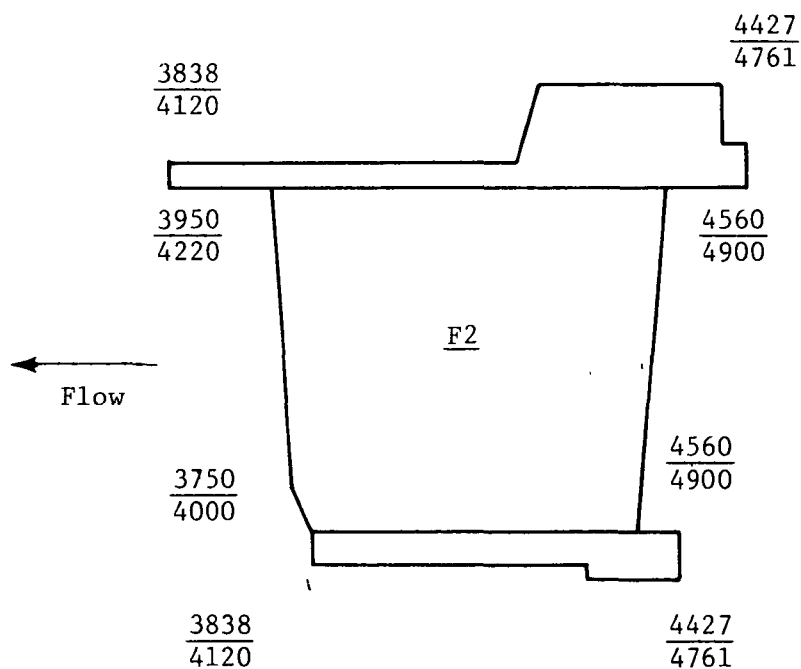
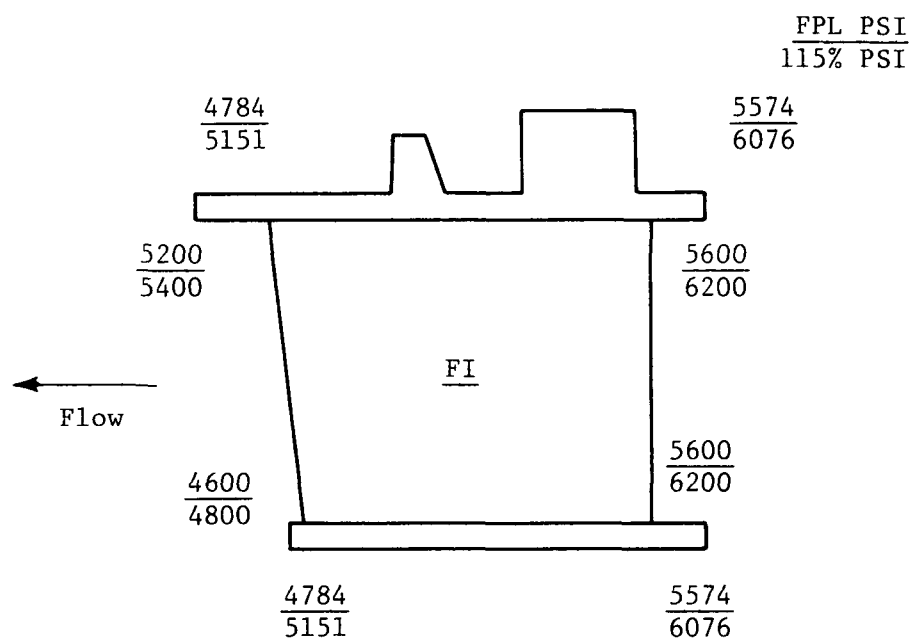

Fig. 3.1-14 Model F1 and F2 Shroud and Hub Pressures

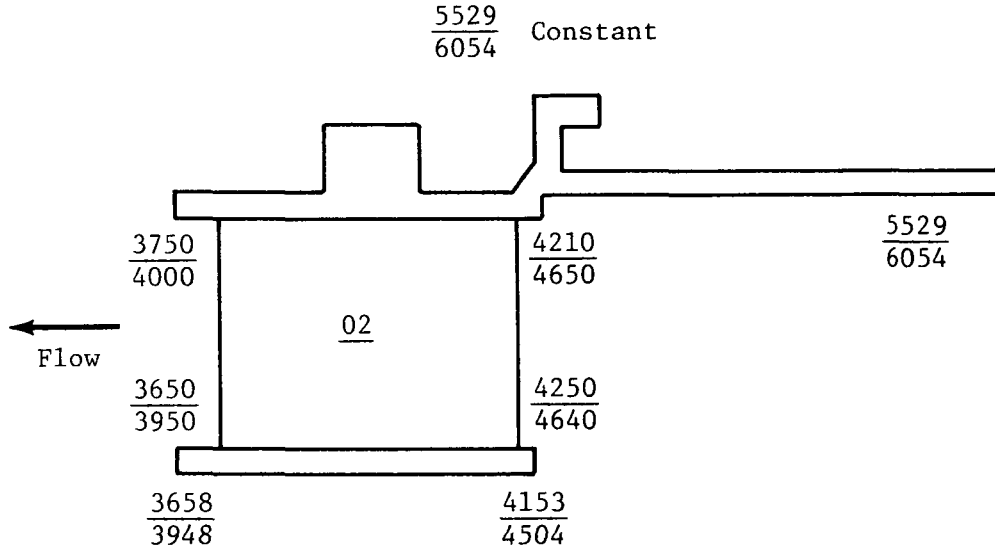
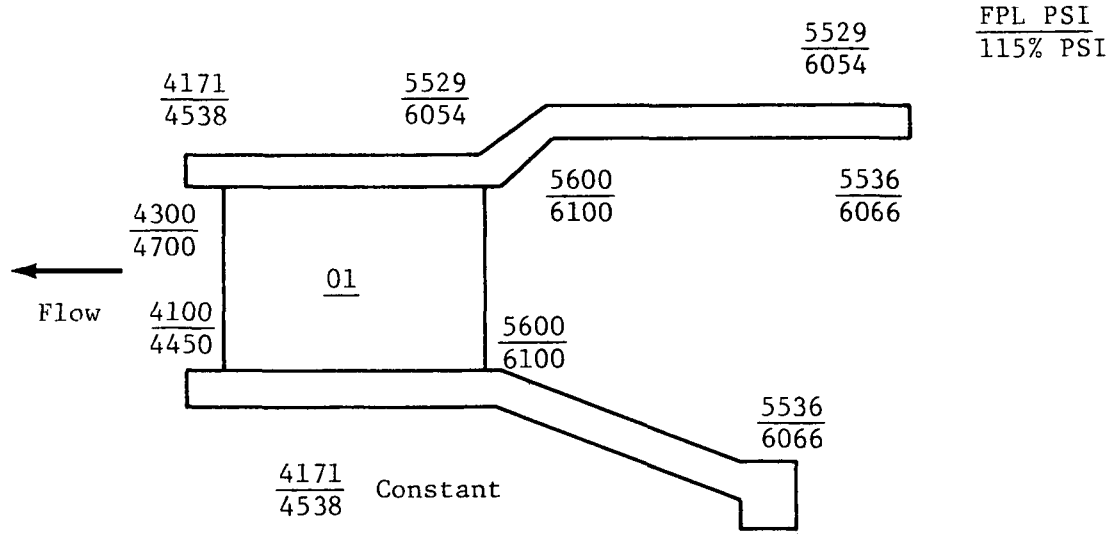

Fig. 3.1-15 Model 01 and 02 Shroud and Hub Pressures

3.2 HPFTP FIRST STAGE NOZZLE STRESSES AT FPL AND 115% RPL

Figure 3.2-1 shows the views that are used in generating contour plots of the nozzles. Stresses are shown in Figs. 3.2-2 through 3.2-43.

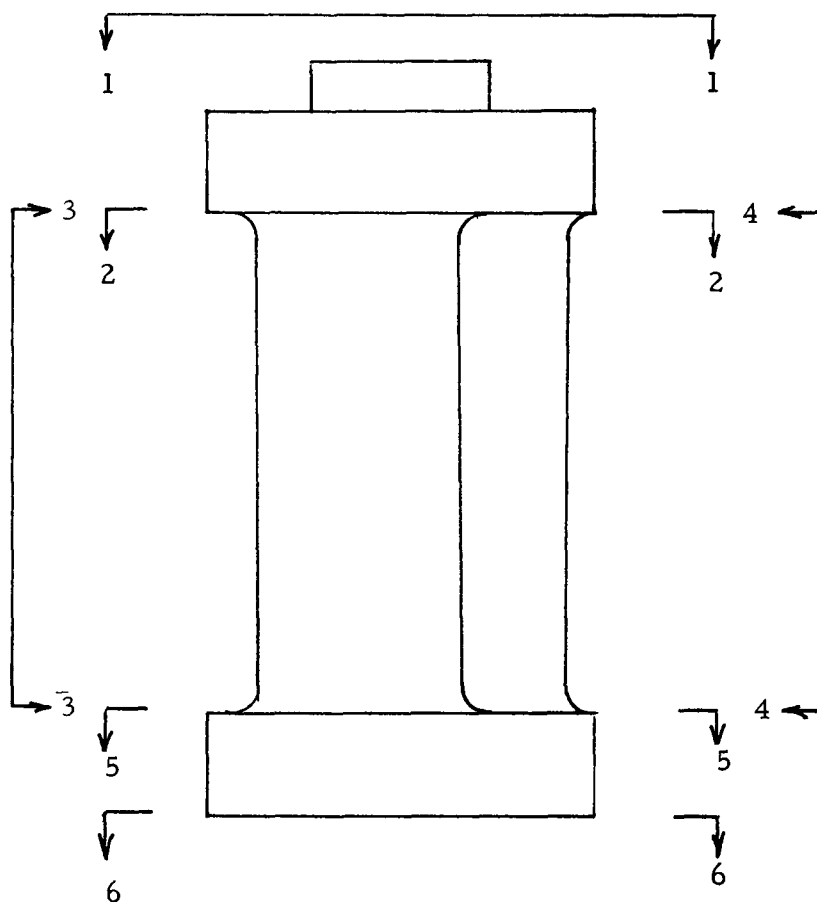

Fig. 3.2-1 Typical Model, Contour Plot Views, Looking with Flow, Radial Upward

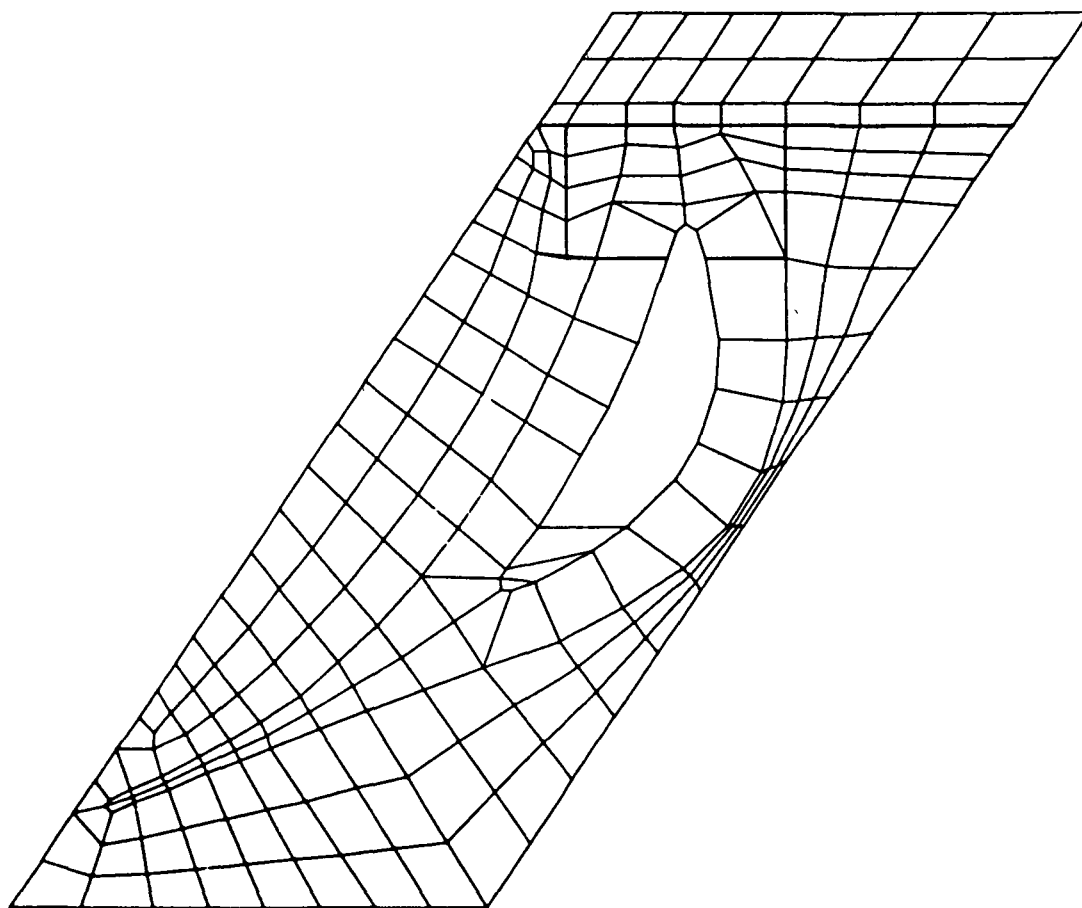
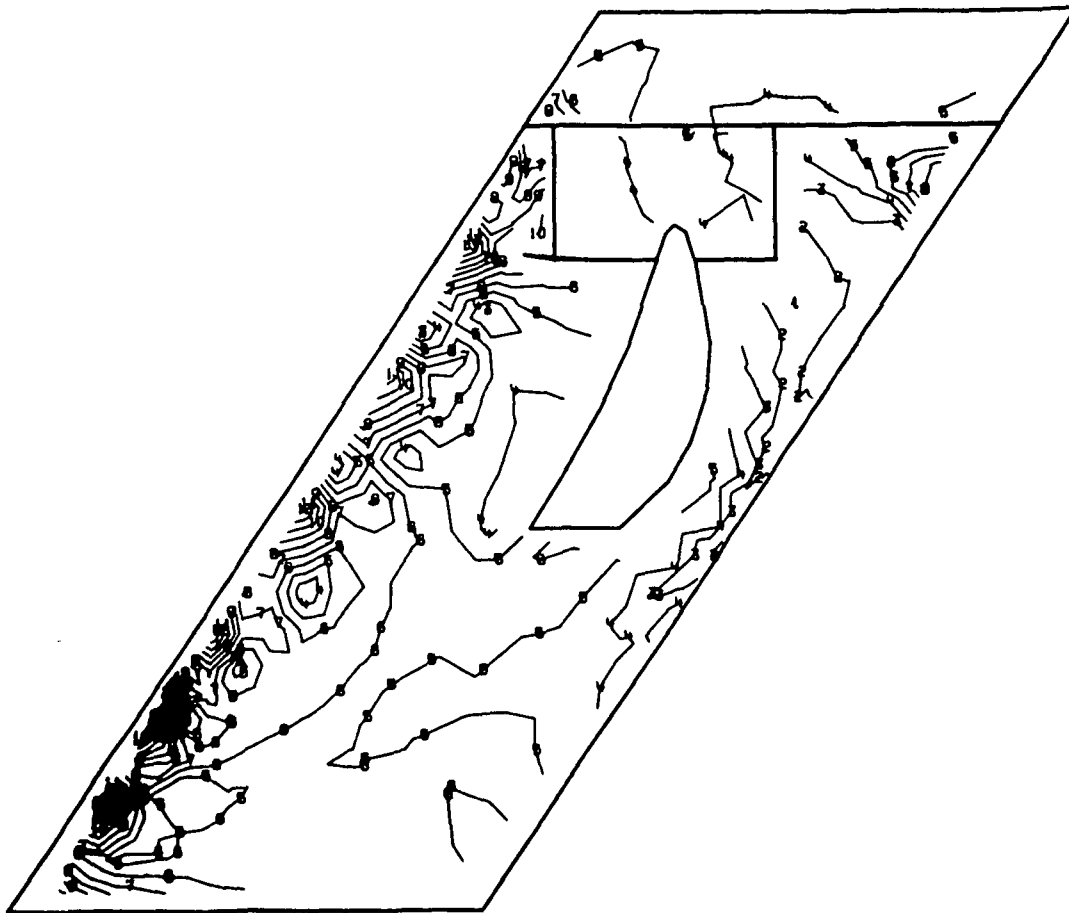
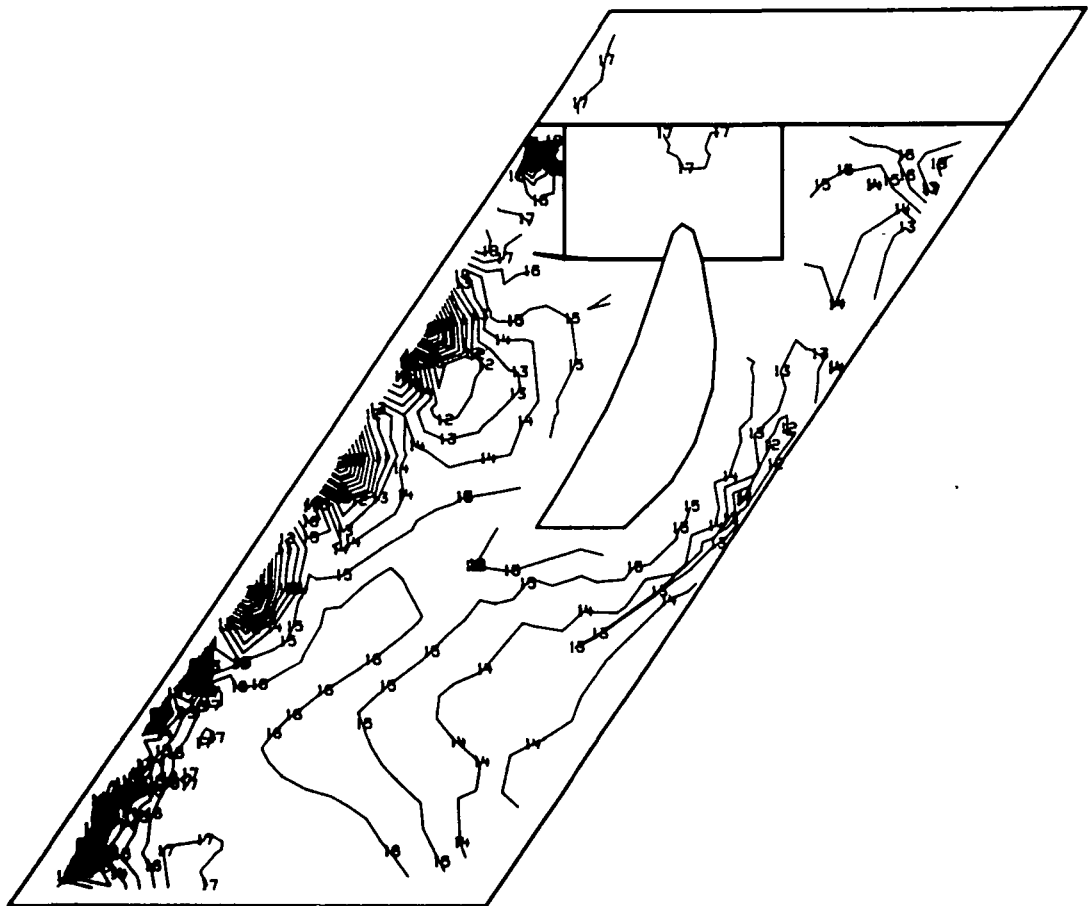

Fig. 3.2-2 Model F1, View 1, Shroud Outside



1	-1.546383E C4	11	5.585289E 04
2	-8.332160E 03	12	6.298456E C4
3	-1.200488E C3	13	7.011619E 04
4	5.931184E C3	14	7.724781E C4
5	1.306286E C4	15	8.437944E 04
6	2.019453E C4	16	9.151106E 04
7	2.732620E C4	17	9.864269E C4
8	3.445787E 04	18	1.057743E C5
9	4.153954E C4	19	1.129059E 05
10	4.872121E 04	20	1.20038CE C5

Fig. 3.2-3 Model F1, FPL Load, View 1, Major Principal Stress (psi)



1	-1.350689E C5	11	-4.825342E C4
2	-1.263874E C5	12	-3.957191E C4
3	-1.177058E C5	13	-3.089041E C4
4	-1.090243E C5	14	-2.220890E C4
5	-1.003427E C5	15	-1.352739E C4
6	-9.166113E C4	16	-4.845883E C3
7	-8.297956E C4	17	3.835625E C2
8	-7.429800E C4	18	1.251713E C4
9	-6.561644E C4	19	2.119864E C4
10	-5.693492E C4	20	2.587976E C4

Fig. 3.2-4 Model F1, FPL Load, View 1, Minor Principal Stress (psi)

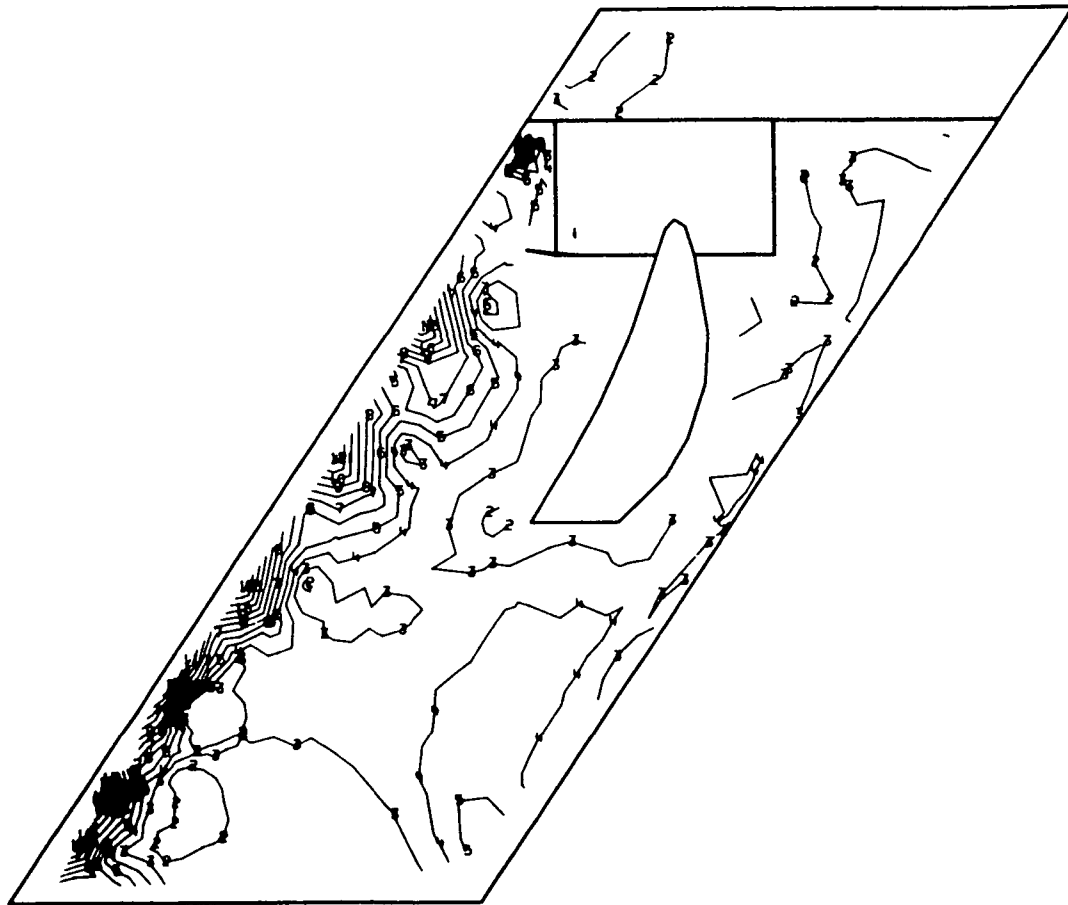

1	4.581016E C2	11	5.607209E 04
2	6.019500E C3	12	6.163348E C4
3	1.15809CE C4	13	6.719488E 04
4	1.714220E 04	14	7.275625E 04
5	2.270370E 04	15	7.831763E C4
6	2.826509E C4	16	8.387900E 04
7	3.382649E C4	17	8.944038E 04
8	3.938789E 04	18	9.500175E C4
9	4.494925E C4	19	1.005631E C5
10	5.051069E 04	20	1.061248E C5

Fig. 3.2-5 Model F1, FPL Load, View 1, Maximum Principal Shear (psi)

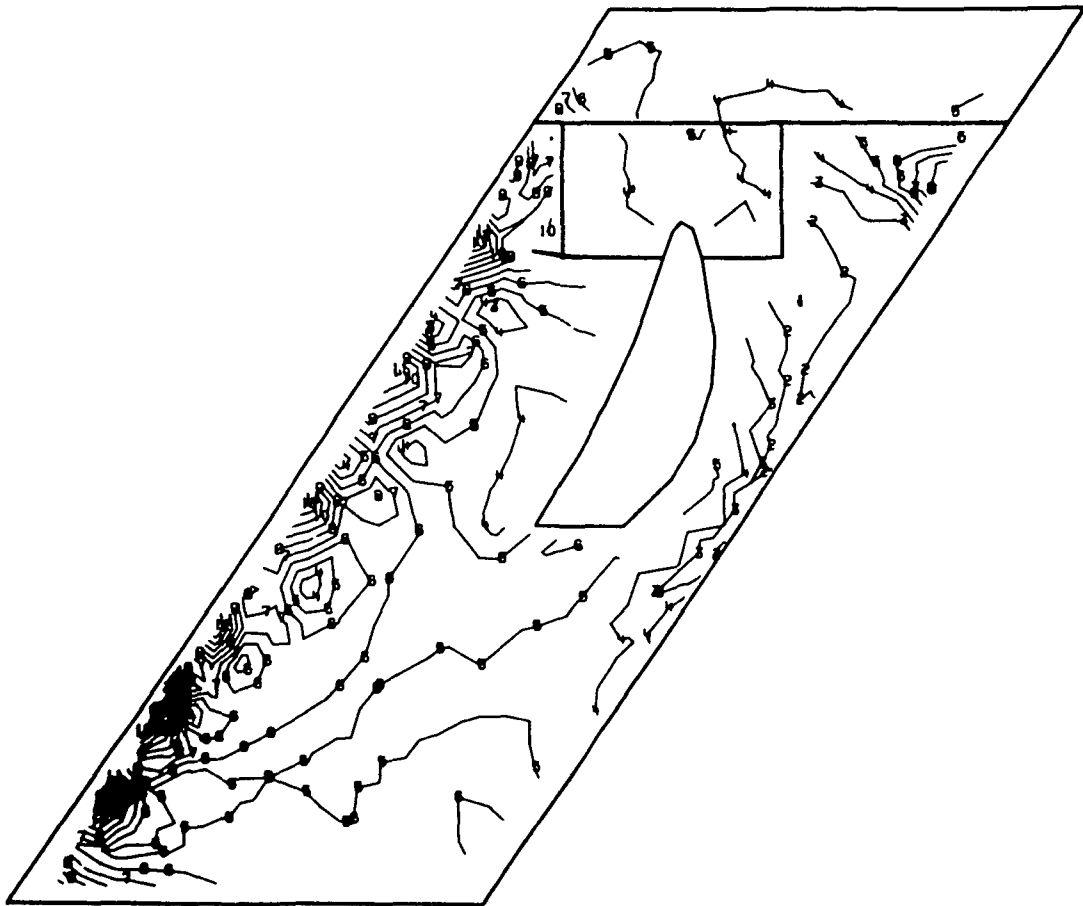

1	-1.541804E 04	11	5.488533E 04
2	-8.387652E 03	12	6.191621E 04
3	-1.357266E 03	13	6.894656E 04
4	5.673121E 03	14	7.597694E 04
5	1.270351E 04	15	8.300731E 04
6	1.973389E 04	16	9.003769E 04
7	2.676428E 04	17	9.706806E 04
8	3.379467E 04	18	1.040984E 05
9	4.082505E 04	19	1.111288E 05
10	4.785544E 04	20	1.181594E 05

Fig. 3.2-6 Model F1, 115% Load, View 1, Major Principal Stress (psi)

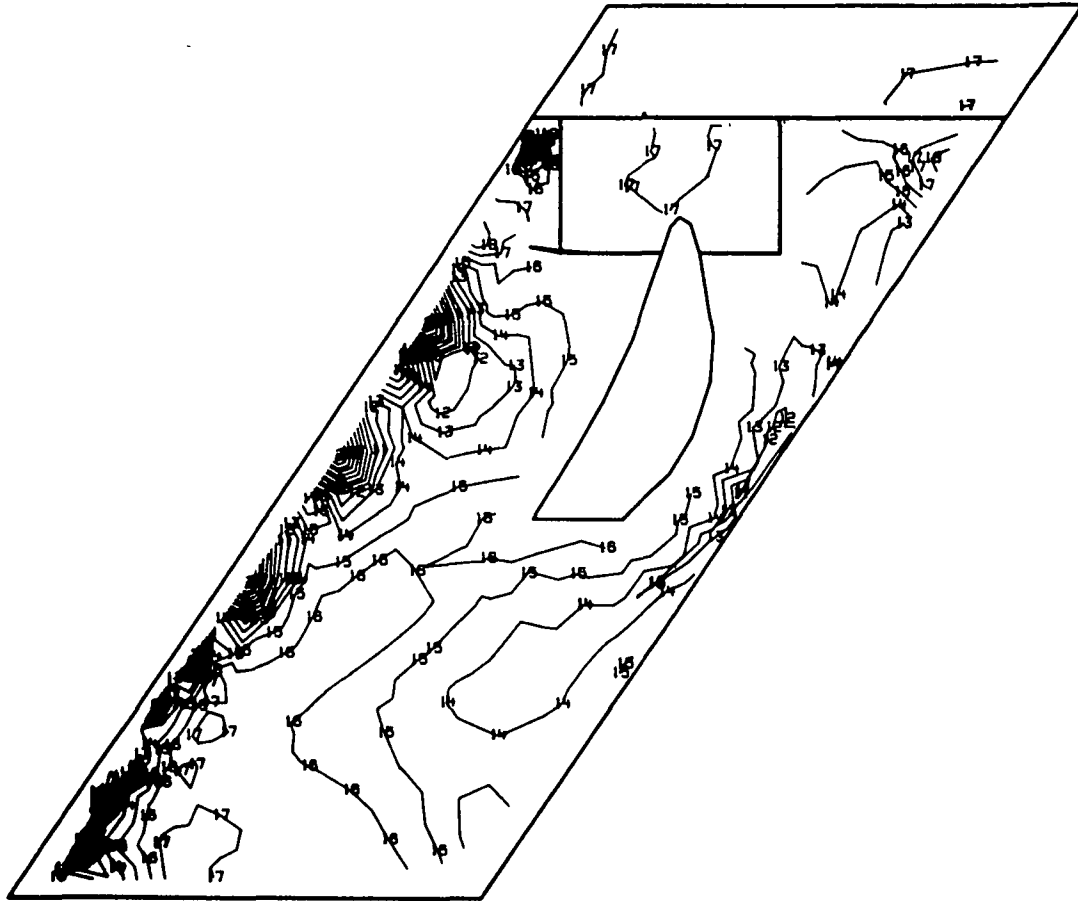

1	-1.308476E 05	11	-4.705079E 04
2	-1.224679E 05	12	-3.867111E 04
3	-1.140883E 05	13	-3.029143E 04
4	-1.057086E 05	14	-2.191176E 04
5	-9.732888E 04	15	-1.353208E 04
6	-8.894919E 04	16	-5.152406E 03
7	-8.056950E 04	17	3.227270E 03
8	-7.218981E 04	18	1.160695E 04
9	-6.381014E 04	19	1.998662E 04
10	-5.543046E 04	20	2.836629E 04

Fig. 3.2-7 Model F1, 115% Load, View 1, Minor Principal Stress (psi)

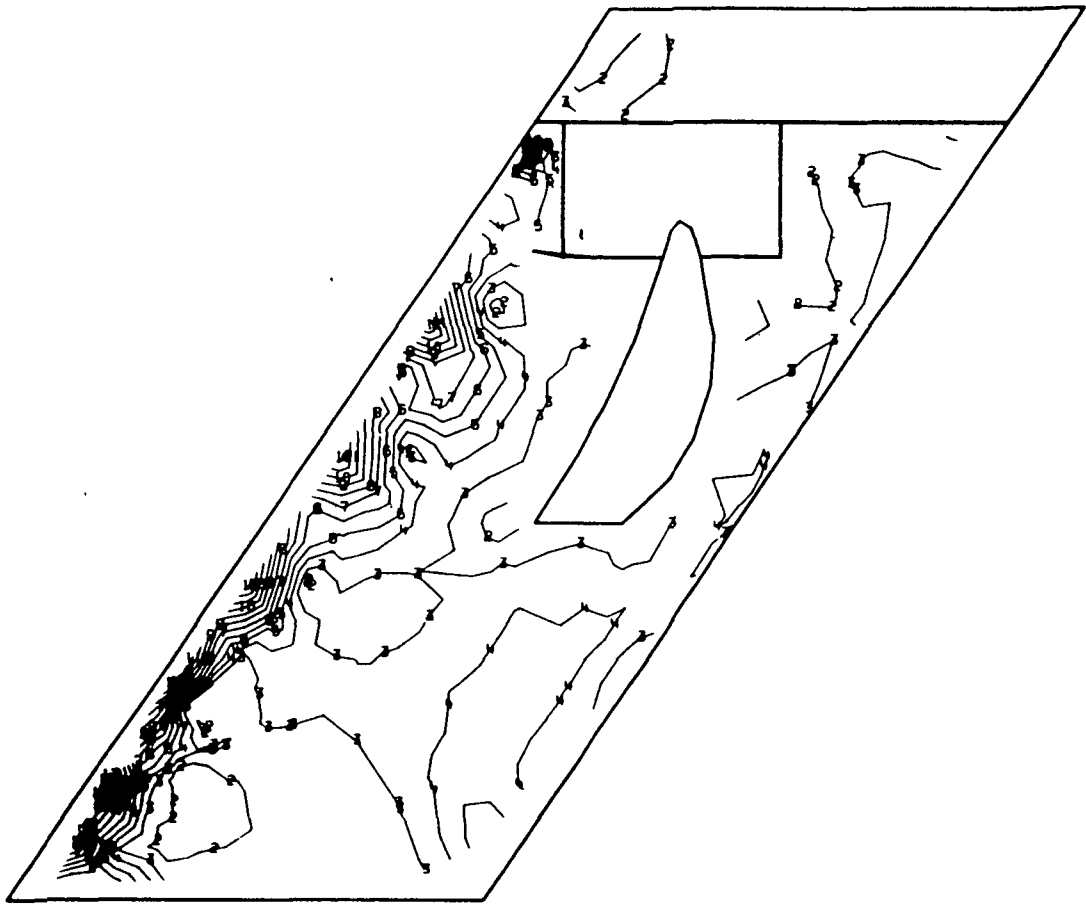

1	4.353794E 02	11	5.377023E 04
2	5.768879E 03	12	5.910398E 04
3	1.110238E 04	13	6.443738E 04
4	1.643588E 04	14	6.977088E 04
5	2.176938E 04	15	7.510438E 04
6	2.710288E 04	16	8.043788E 04
7	3.243638E 04	17	8.577138E 04
8	3.776988E 04	18	9.110488E 04
9	4.310338E 04	19	9.643838E 04
10	4.843688E 04	20	1.017719E 05

Fig. 3.2-8 Model F1, 115% Load, View 1, Maximum Principal Shear (psi)

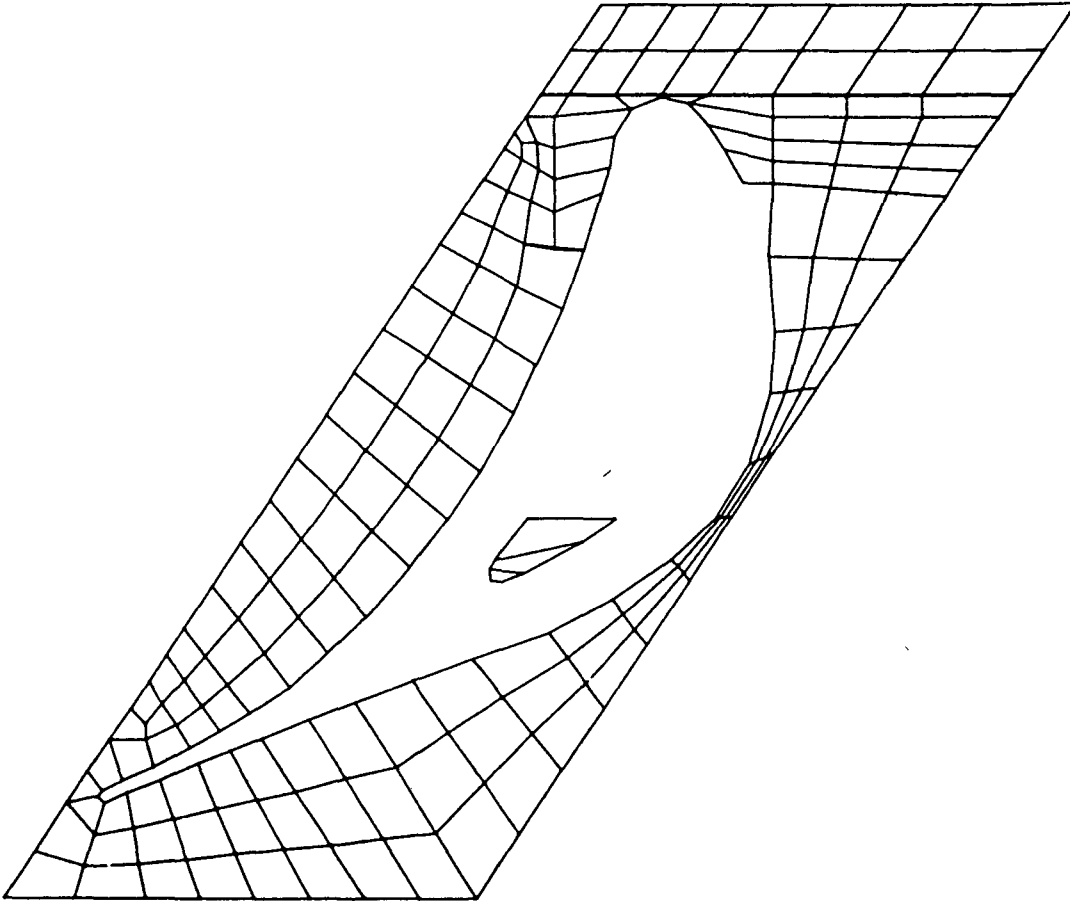
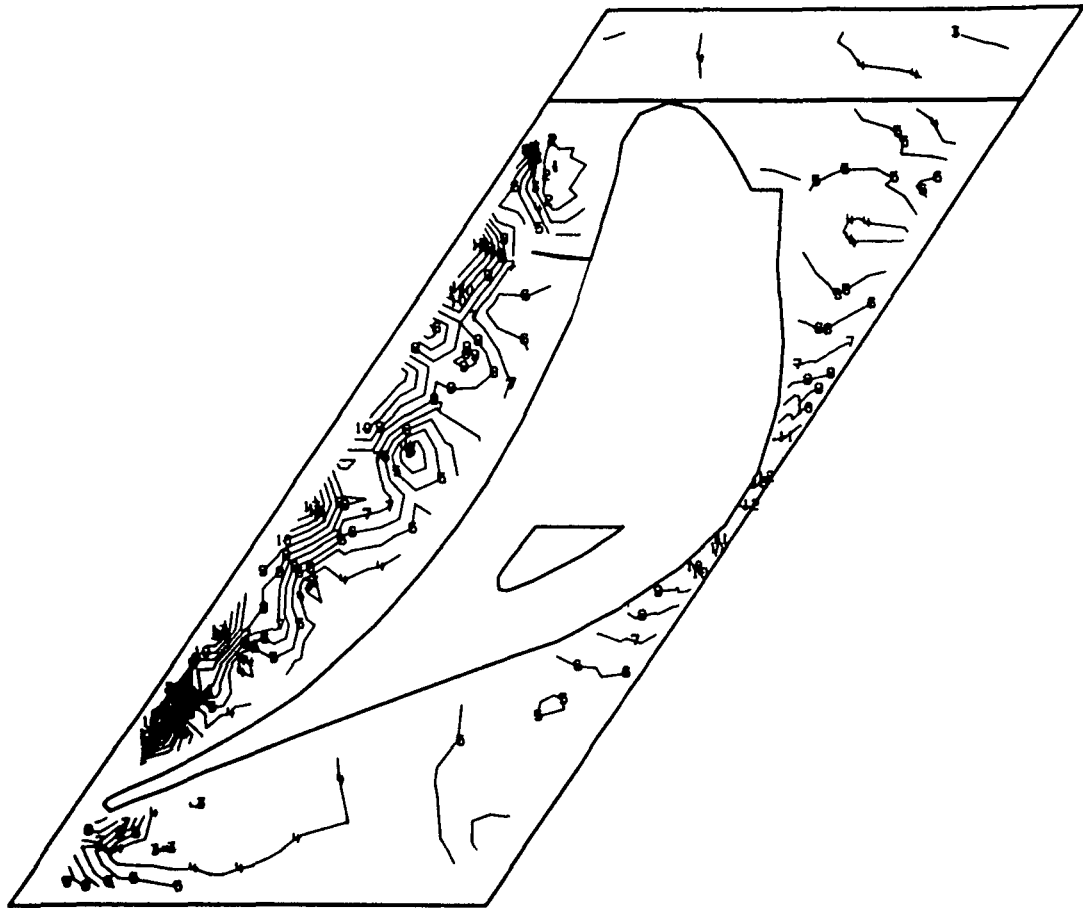
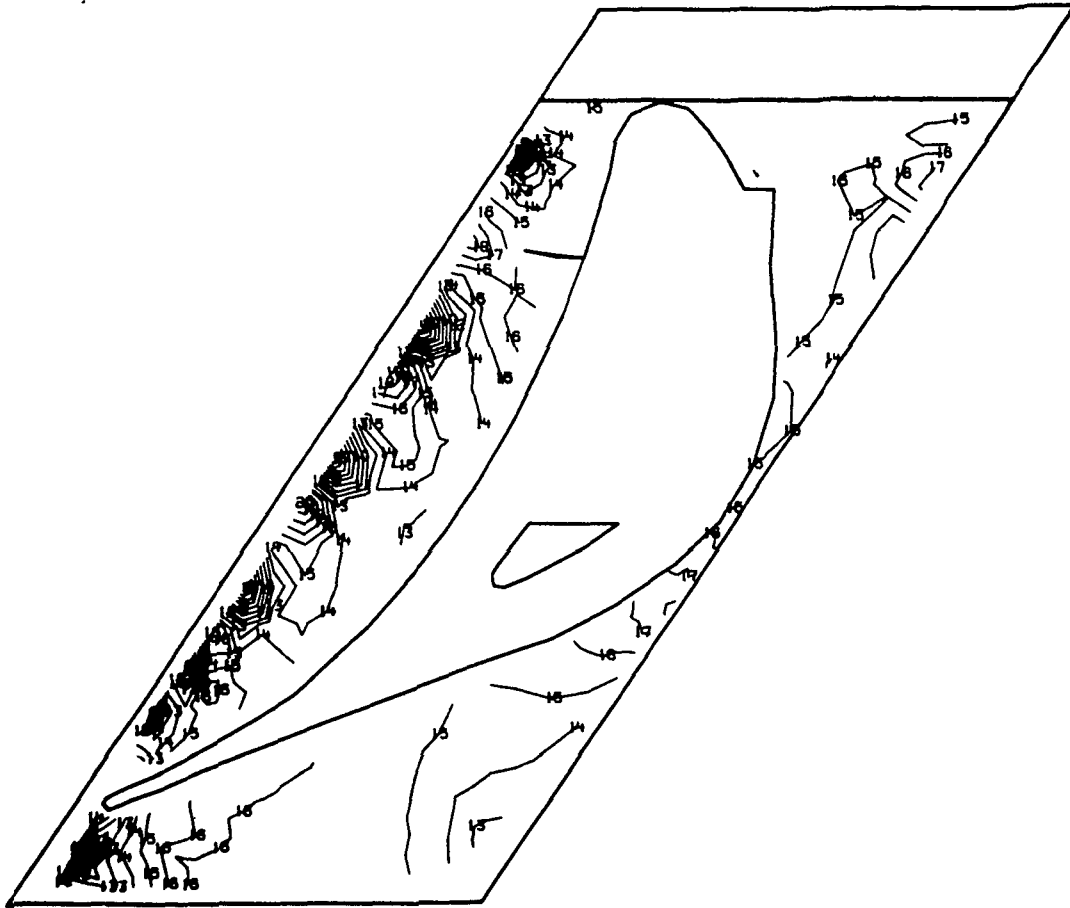

Fig. 3.2-9 Model F1, View 2, Shroud Inside



1	-6.528996E C3	11	6.443870E C4
2	5.677734E O2	12	7.153544E C4
3	7.664543E C3	13	7.863219E C4
4	1.476131E O4	14	8.572894E C4
5	2.185808E C4	15	9.282569E C4
6	2.895485E C4	16	9.992244E C4
7	3.605162E O4	17	1.070192E C5
8	4.314839E C4	18	1.141159E C5
9	5.024516E C4	19	1.212127E C5
10	5.734193E O4	20	1.283097E C5

Fig. 3.2-10 Model F1, FPL Load, View 2, Major Principal Stress (psi)



1	-1.485741E C5	11	-4.582166E C4
2	-1.382788E C5	12	-3.522645E O4
3	-1.279826E C5	13	-2.503125E C4
4	-1.176883E O5	14	-1.473605E C4
5	-1.073921E C5	15	-4.440844E C3
6	-9.709781E O4	16	5.854359E C3
7	-8.680256E C4	17	1.614956E C4
8	-7.650721E O4	18	2.644477E O4
9	-6.621206E O4	19	2.673957E C4
10	-5.591686E C4	20	4.703486E O4

Fig. 3.2-11 Model F1, FPL Load, View 2, Minor Principal Stress (psi)

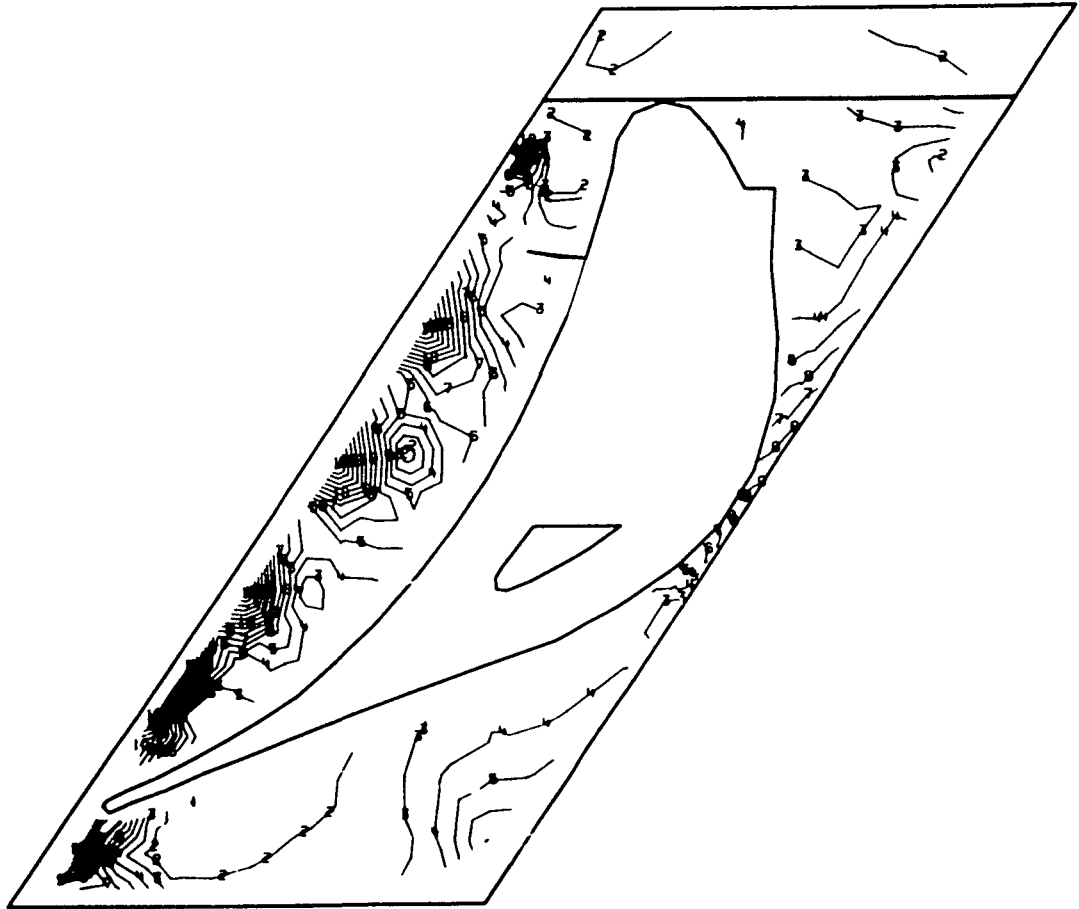

1	4.739033E 02	11	5.085410E 04
2	5.511922E 03	12	5.589212E 04
3	1.054994E 04	13	6.093014E 04
4	1.558796E 04	14	6.596813E 04
5	2.062598E 04	15	7.100612E 04
6	2.566400E 04	16	7.604413E 04
7	3.070202E 04	17	8.108213E 04
8	3.574004E 04	18	8.612013E 04
9	4.077806E 04	19	9.115813E 04
10	4.581608E 04	20	9.619638E 04

Fig. 3.2-12 Model F1, FPL Load, View 2, Maximum Principal Shear (psi)

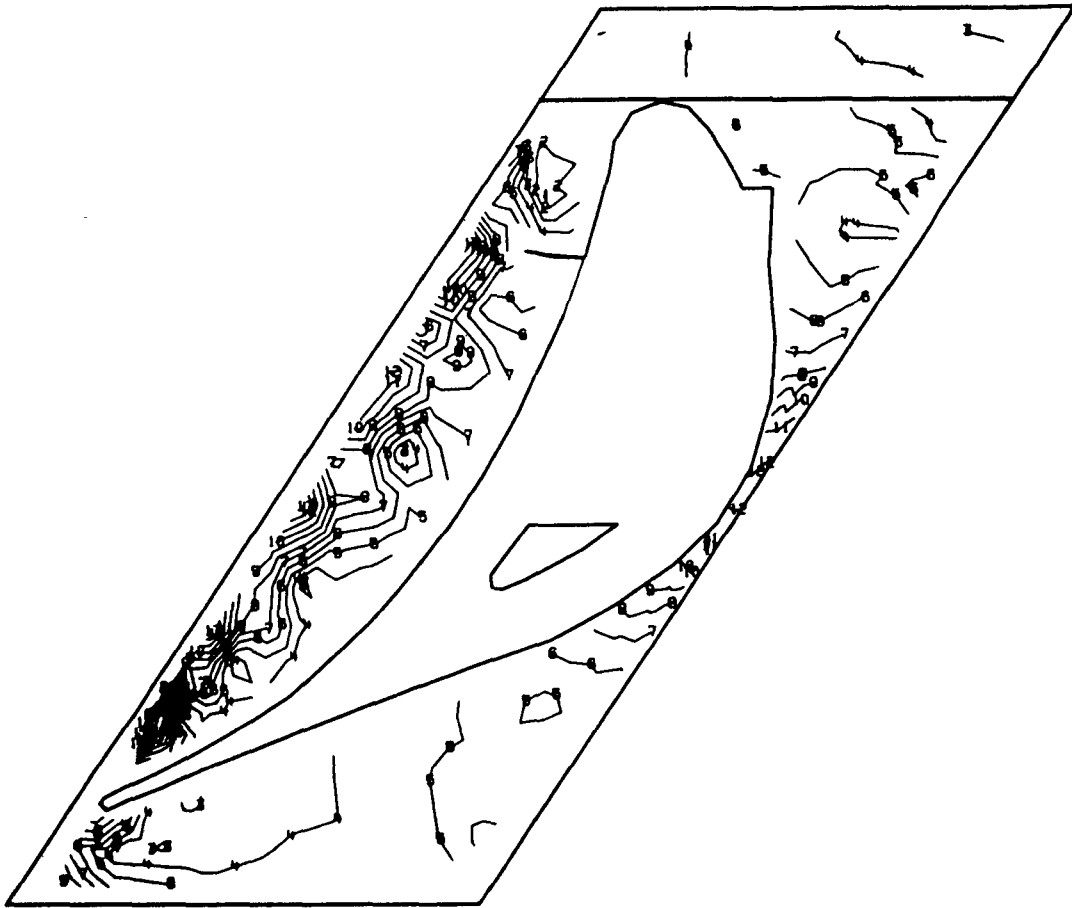

1	-6.991555E 03	11	6.223778E 04
2	-6.862109E 01	12	6.916069E 04
3	6.854313E 03	13	7.608356E 04
4	1.377725E 04	14	8.300644E 04
5	2.070018E 04	15	8.992931E 04
6	2.762311E 04	16	9.685219E 04
7	3.454605E 04	17	1.037751E 05
8	4.146898E 04	18	1.106979E 05
9	4.839191E 04	19	1.176208E 05
10	5.531485E 04	20	1.245443E 05

Fig. 3.2-13 Model F1, 115% Load, View 2, Major Principal Stress (psi)

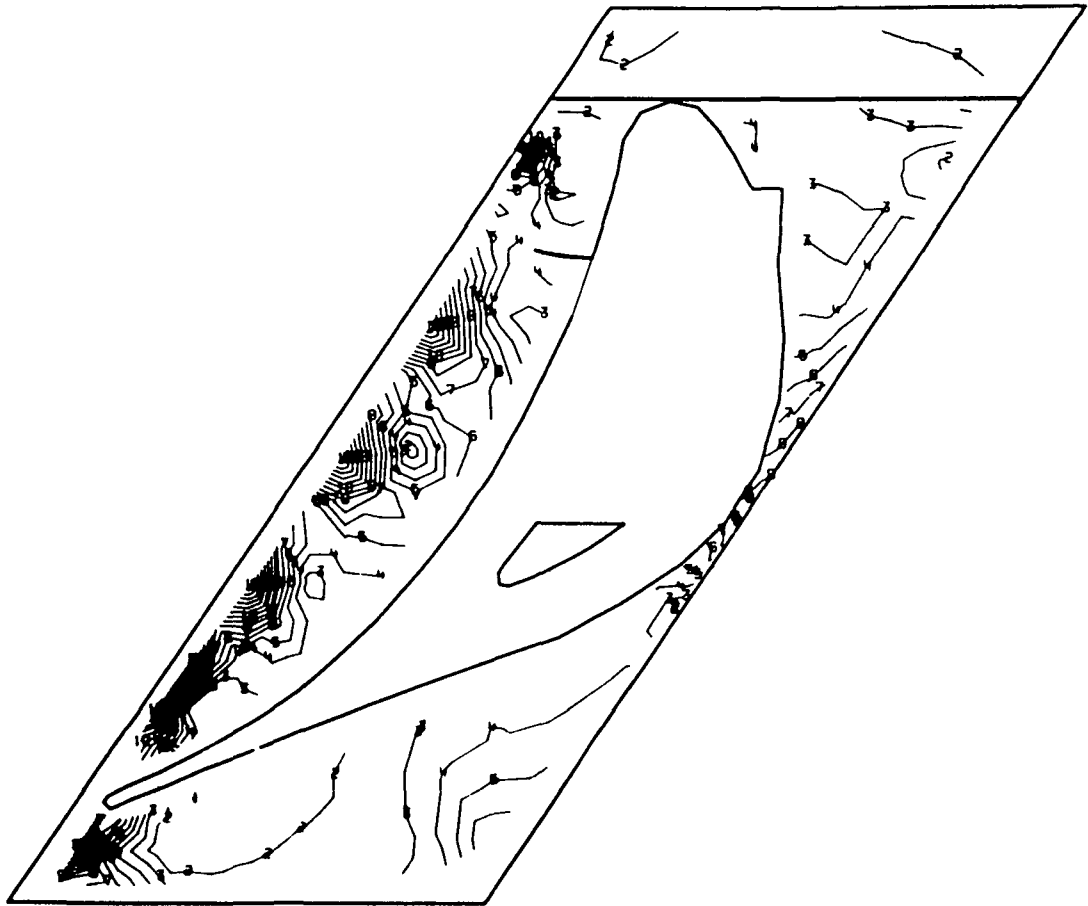

1	1.286117E 02	11	4.879580E 04
2	4.995328E 03	12	5.366252E 04
3	9.862047E 03	13	5.852923E 04
4	1.472877E 04	14	6.339595E 04
5	1.959548E 04	15	6.826263E 04
6	2.446220E 04	16	7.312931E 04
7	2.932892E 04	17	7.799600E 04
8	3.419564E 04	18	8.286269E 04
9	3.906236E 04	19	8.772938E 04
10	4.392908E 04	20	9.259631E 04

Fig. 3.2-14 Model F1, 115% Load, View 2, Minor Principal Stress (psi)

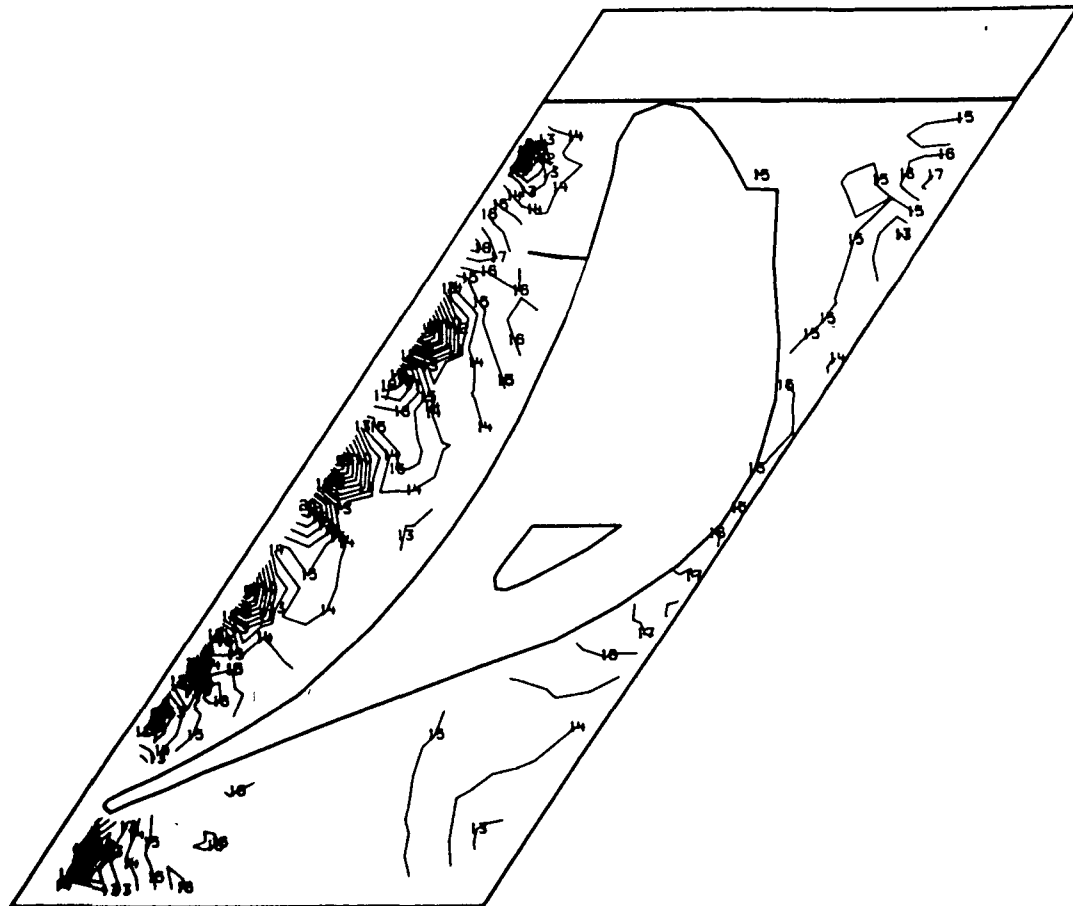

1	-1.441365F 05	11	-4.397538E 04
2	-1.341204E 05	12	-3.395930E 04
3	-1.241043E 05	13	-2.394321E 04
4	-1.140881E 05	14	-1.392713E 04
5	-1.040720E 05	15	-3.911051E 03
6	-9.405588E 04	16	6.105031E 03
7	-8.403975E 04	17	1.612111E 04
8	-7.402363E 04	18	2.613720E 04
9	-6.400754E 04	19	3.615328E 04
10	-5.399146E 04	20	4.616918E 04

Fig. 3.2-15 Model F1, 115% Load, View 2, Maximum Principal Shear (psi)

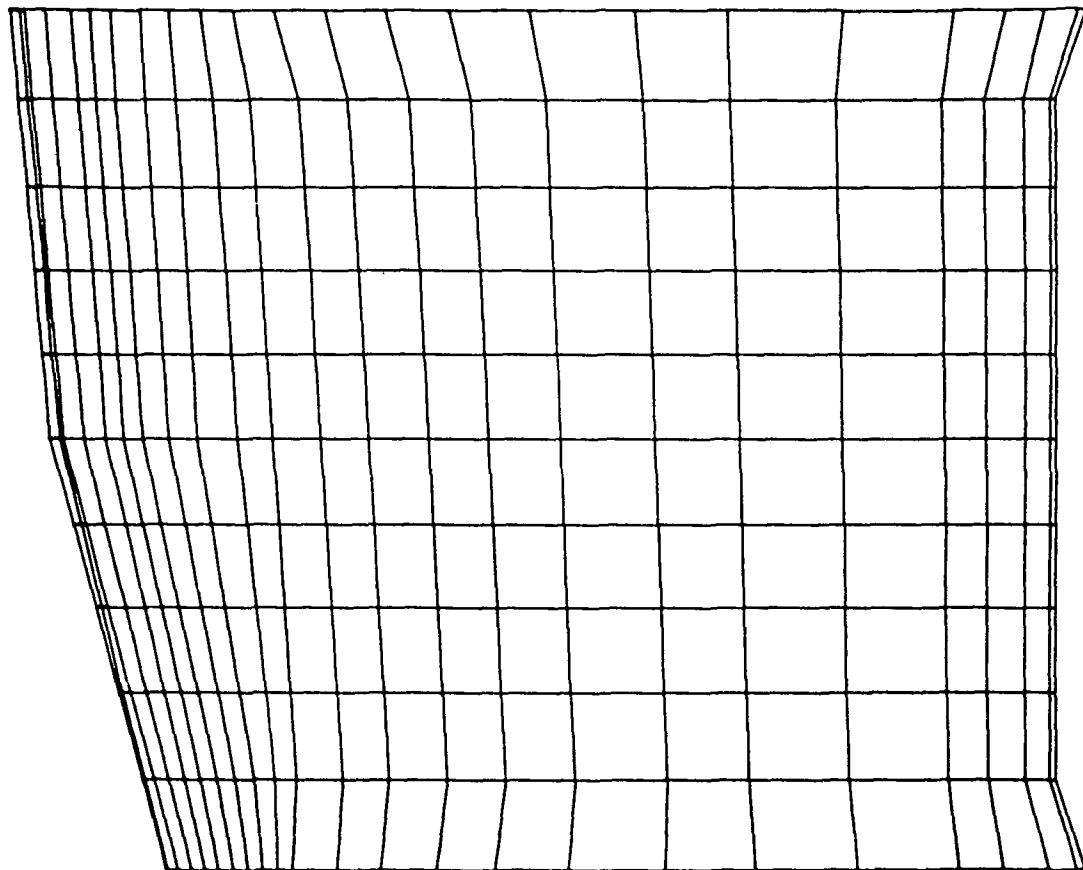
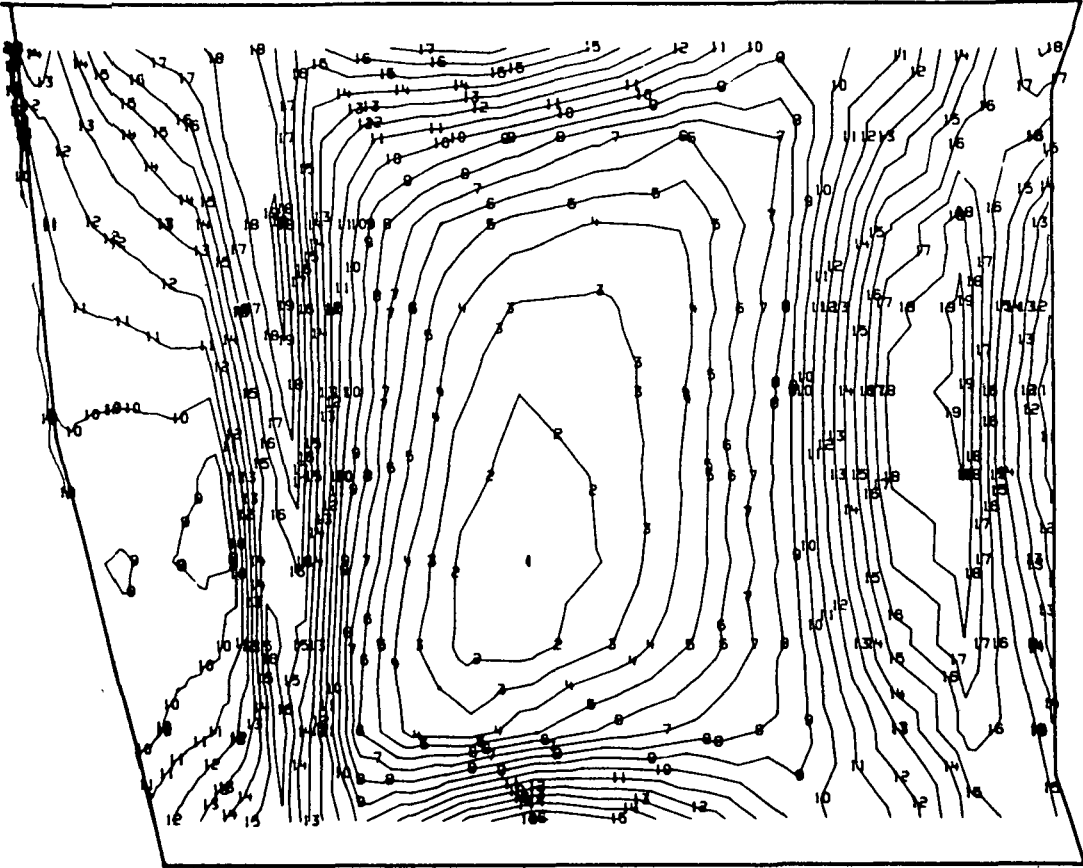
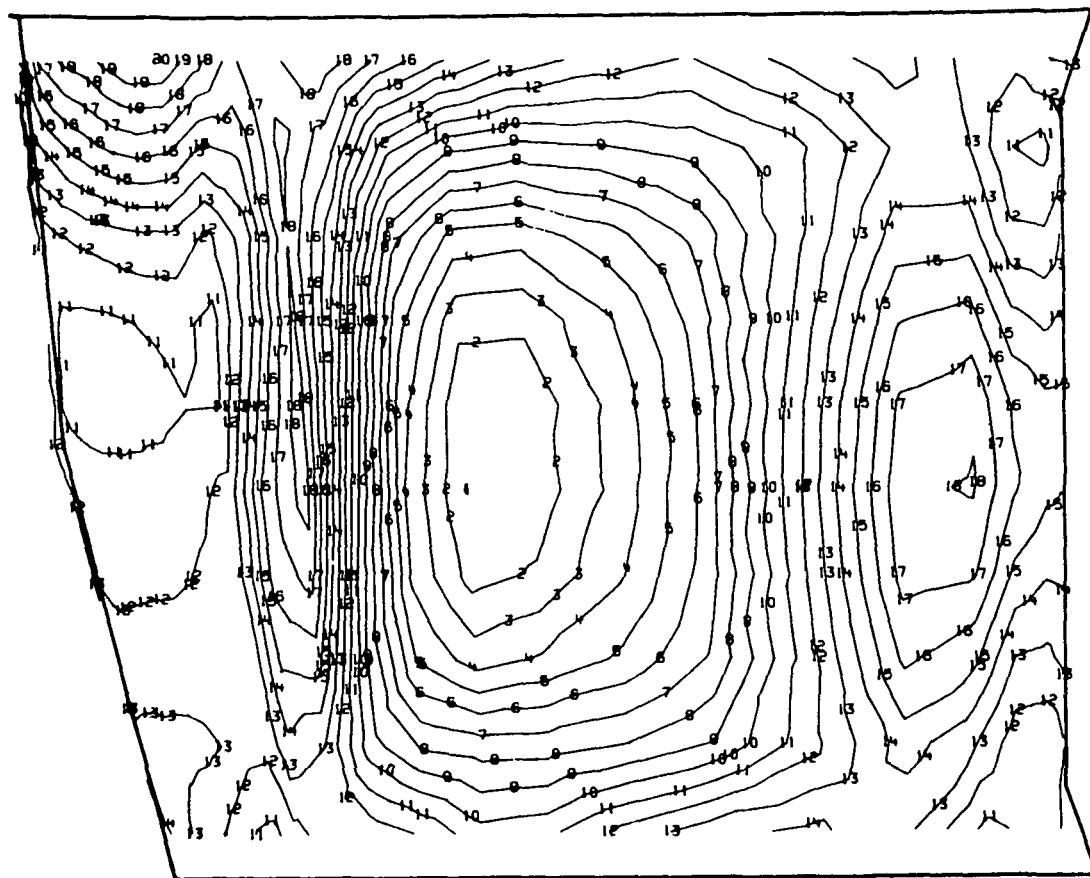

Fig. 3.2-16 Model F1, View 3, Airfoil Suction Side



1	-2.744532E C4	11	1.446114E C3
2	-2.455618E U4	12	4.335254E C3
3	-2.166704E C4	13	7.224395E C3
4	-1.877789E C4	14	1.011254E C4
5	-1.588875E C4	15	1.300268E U4
6	-1.299960E C4	16	1.589182E U4
7	-1.011046E C4	17	1.878056E C4
8	-7.221313E C3	18	2.167010E U4
9	-4.332168E C3	19	2.455924E C4
10	-1.443027E C3	20	2.744836E C4

Fig. 3.2-17 Model F1, FPL Load, View 3, Major Principal Stress (psi)



1	-4.496456E C4	11	-1.556325E C4
2	-4.202444E C4	12	-1.262323E C4
3	-3.908432E C4	13	-5.683105E C2
4	-3.614420E C4	14	-6.742984E C3
5	-3.320407E C4	15	-3.802864E C3
6	-3.026395E C4	16	-8.627437E C2
7	-2.732383E C4	17	2.077377E C3
8	-2.438371E C4	18	5.017496E C3
9	-2.144359E C4	19	7.957613E C3
10	-1.850347E C4	20	1.089773E C4

Fig. 3.2-18 Model F1, FPL Load, View 3, Minor Principal Stress (psi)

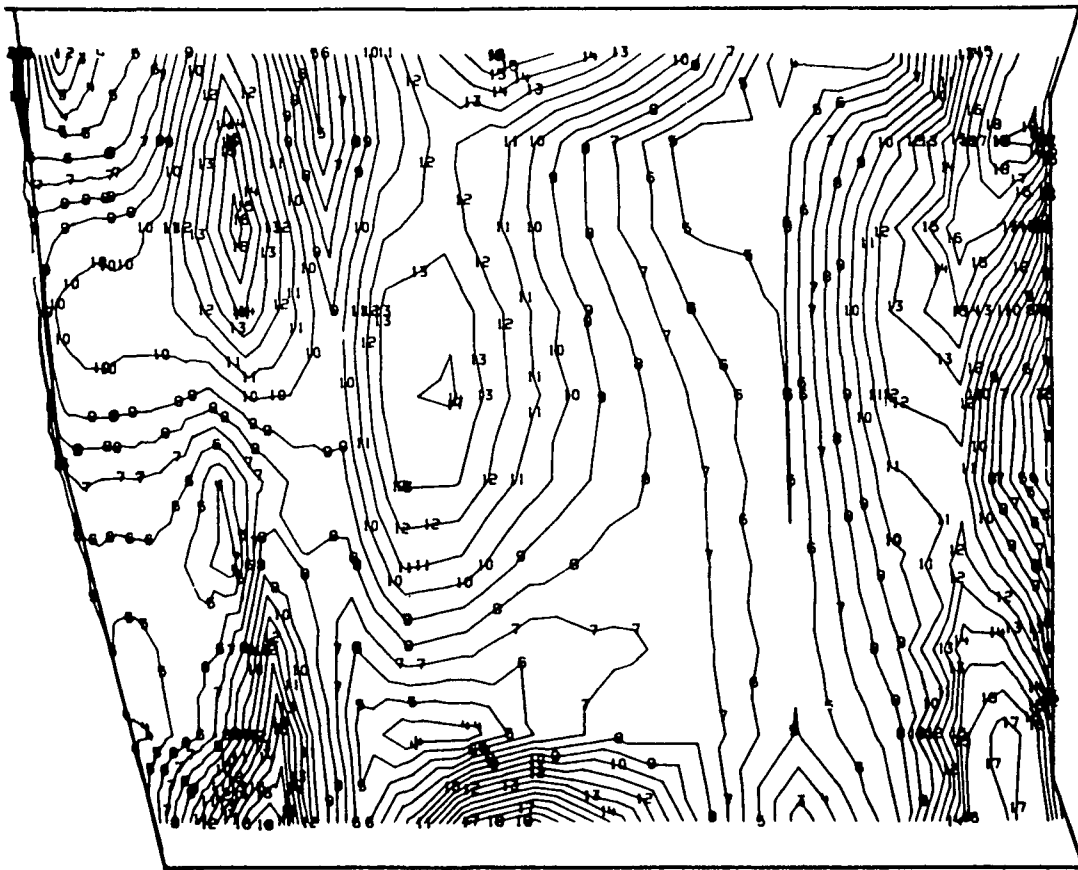

1	4.974826E C2	11	9.160266E 02
2	1.263763E C3	12	1.002654E C4
3	2.230042E C3	13	1.085282E C4
4	3.056322E C3	14	1.175910E C4
5	3.962601E C3	15	1.262528E C4
6	4.828879E C3	16	1.349165E C4
7	5.695156E C3	17	1.435793E C4
8	6.561434E C3	18	1.522421E 04
9	7.427711E C3	19	1.609048E C4
10	8.293988E C3	20	1.695679E C4

Fig. 3.2-19 Model F1, FPL Load, View 3, Maximum Principal Shear (psi)

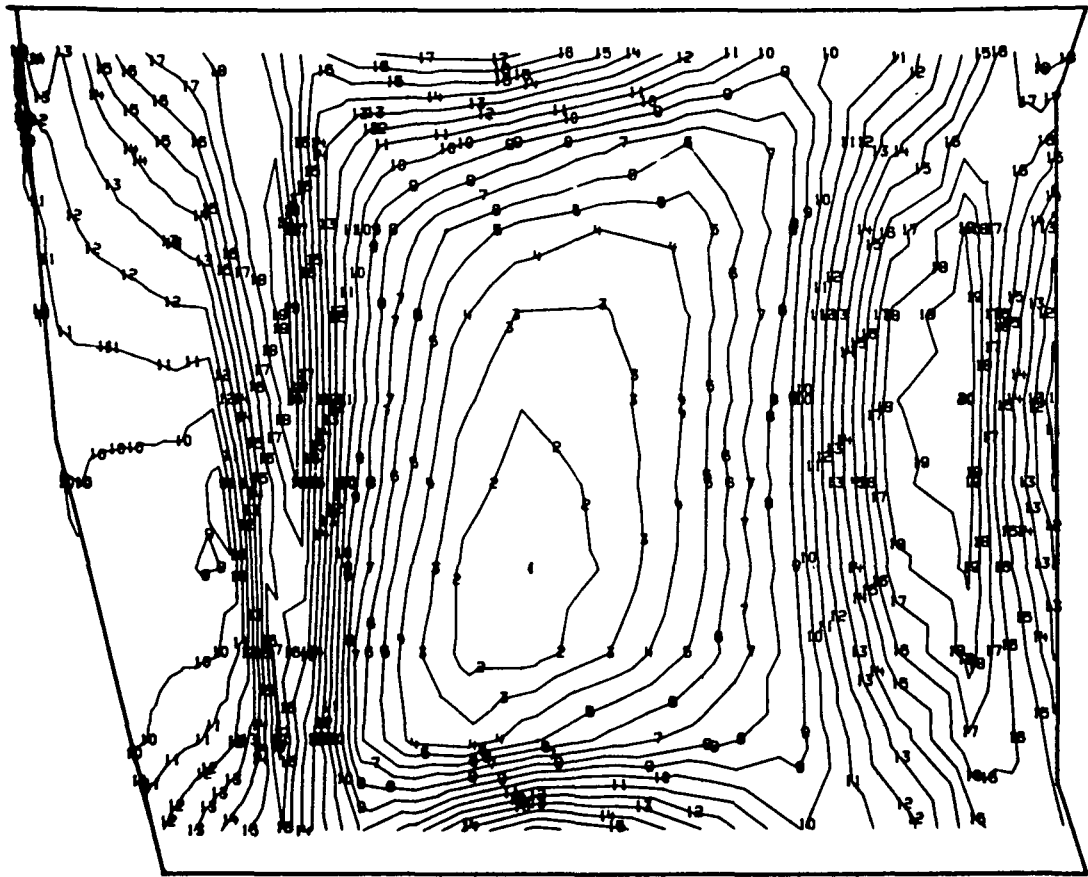

1	-2.784546E 04	11	3.826641E 02
2	-2.502265E 04	12	3.205477E 03
3	-2.219984E 04	13	6.028289E 03
4	-1.937702E 04	14	8.851102E 03
5	-1.655421E 04	15	1.167391E 04
6	-1.373140E 04	16	1.449673E 04
7	-1.090859E 04	17	1.731954E 04
8	-8.085773E 03	18	2.014235E 04
9	-5.262961E 03	19	2.296516E 04
10	-2.440148E 03	20	2.578798E 04

Fig. 3.2-20 Model F1, 115% Load, View 3, Major Principal Stress (psi)

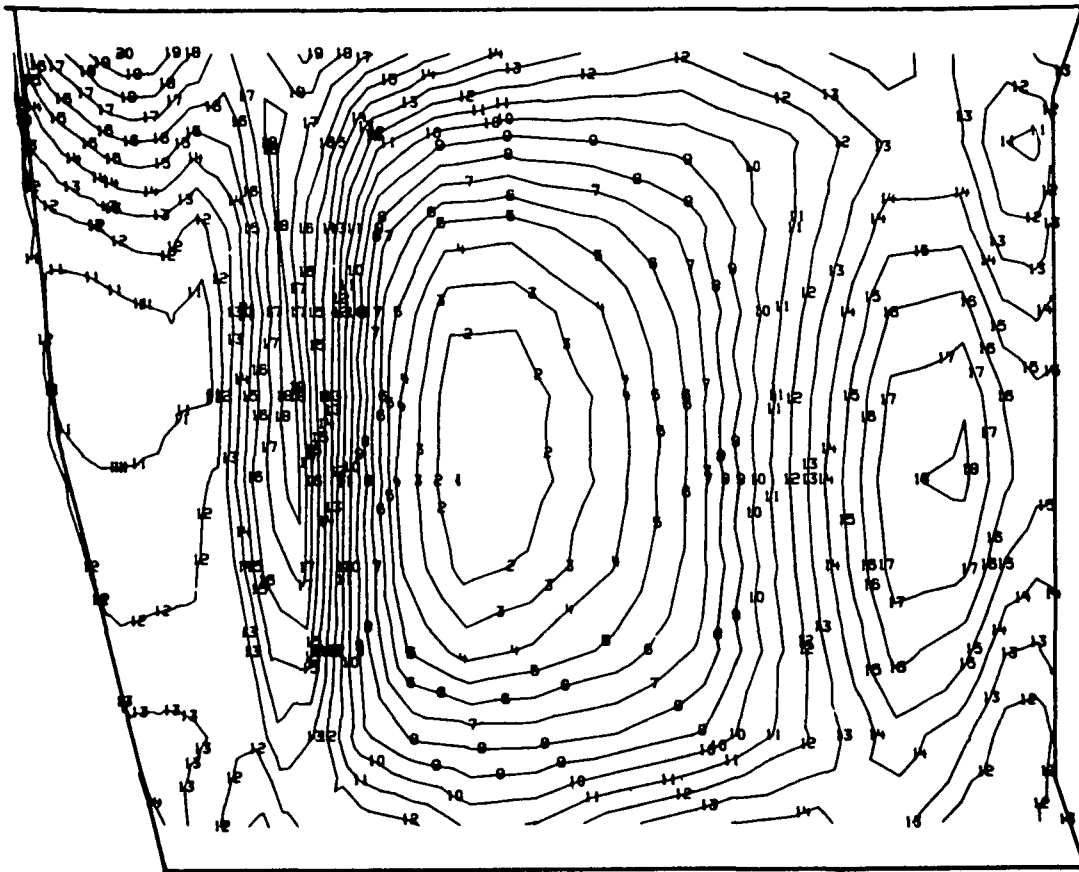

1	-4.491202E 04	11	-1.609550E 04
2	-4.203037E 04	12	-1.321384E 04
3	-3.914871E 04	13	-1.033219E 04
4	-3.626706E 04	14	-7.450539E 03
5	-3.338541E 04	15	-4.568887E 03
6	-3.050376E 04	16	-1.687238E 03
7	-2.762211E 04	17	1.194412E 03
8	-2.474045E 04	18	4.076061E 03
9	-2.185880E 04	19	6.957707E 03
10	-1.897715E 04	20	9.839316E 03

Fig. 3.2-21 Model F1, 115% Load, View 3, Minor Principal Stress (psi)

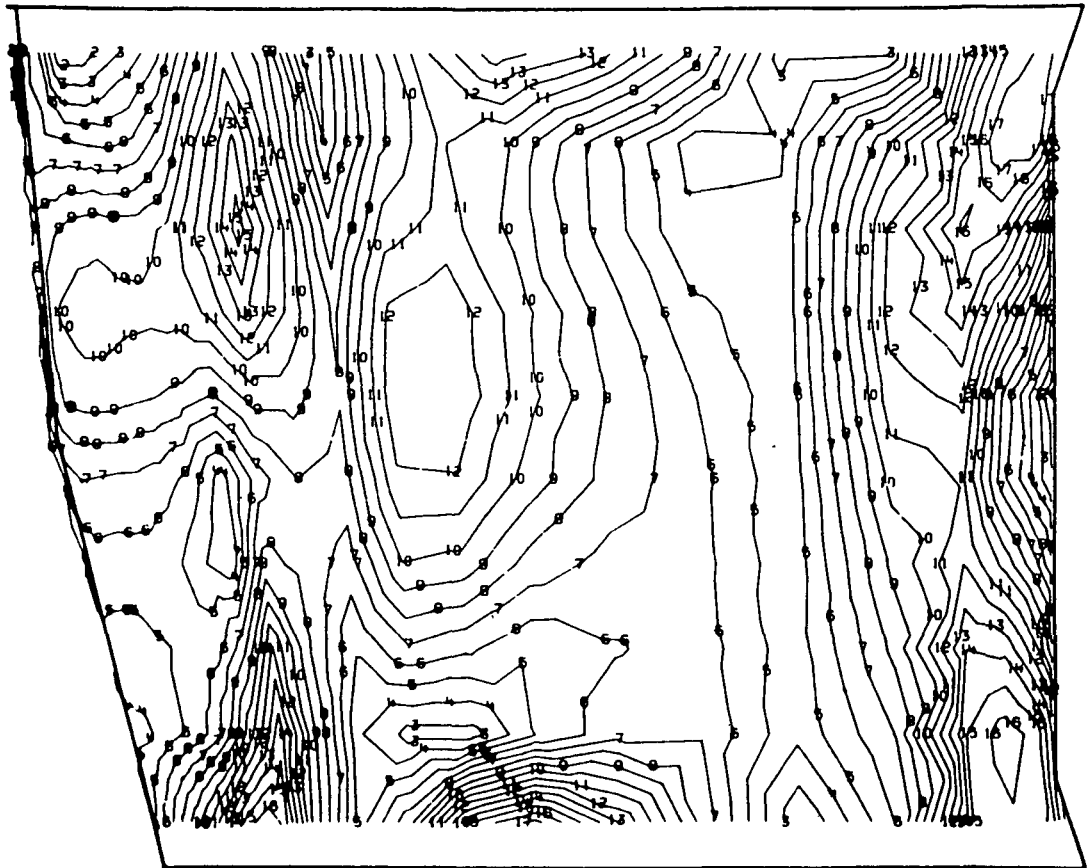

1	1.002991E 03	11	9.897719E 03
2	1.892465E 03	12	1.078719E 04
3	2.781938E 03	13	1.167566E 04
4	3.671412E 03	14	1.256614E 04
5	4.560883E 03	15	1.345561E 04
6	5.450355E 03	16	1.434508E 04
7	6.339828E 03	17	1.523455E 04
8	7.229301E 03	18	1.612403E 04
9	8.118773E 03	19	1.701350E 04
10	9.008246E 03	20	1.790300E 04

Fig. 3.2-22 Model F1, 115% Load, View 3, Maximum Principal Shear (psi)

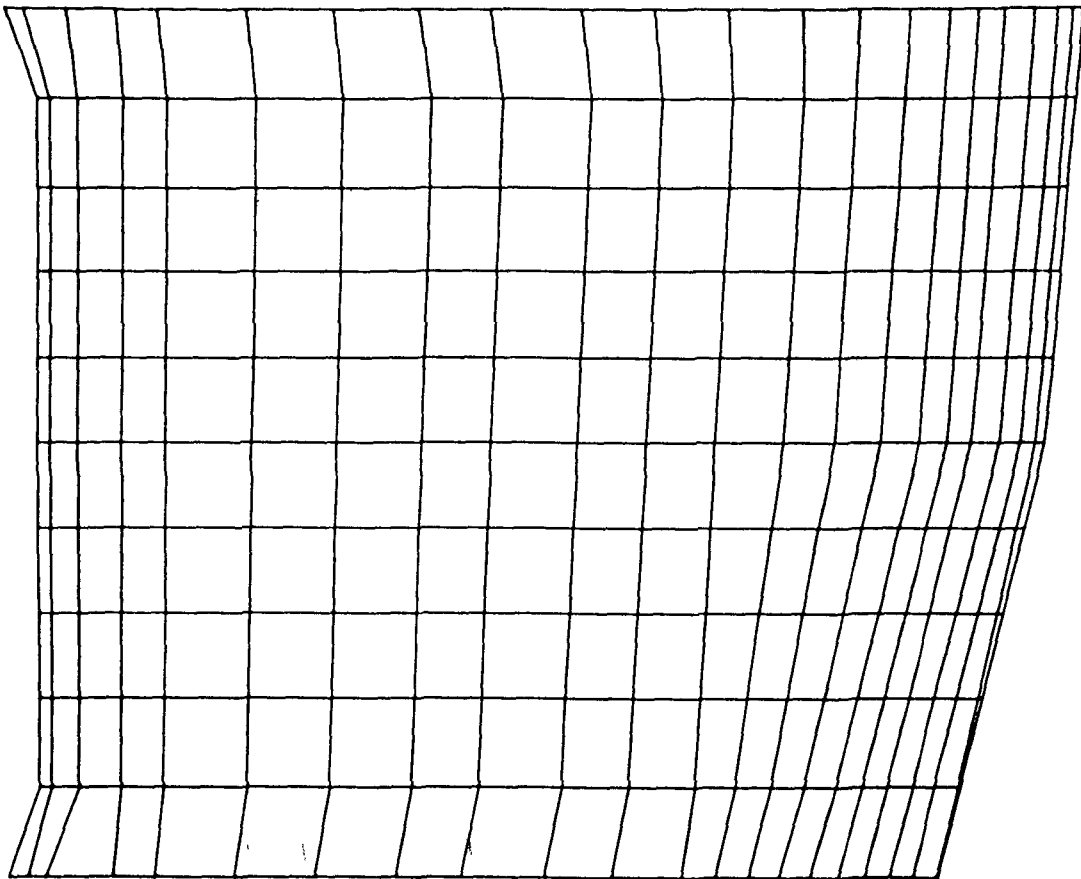
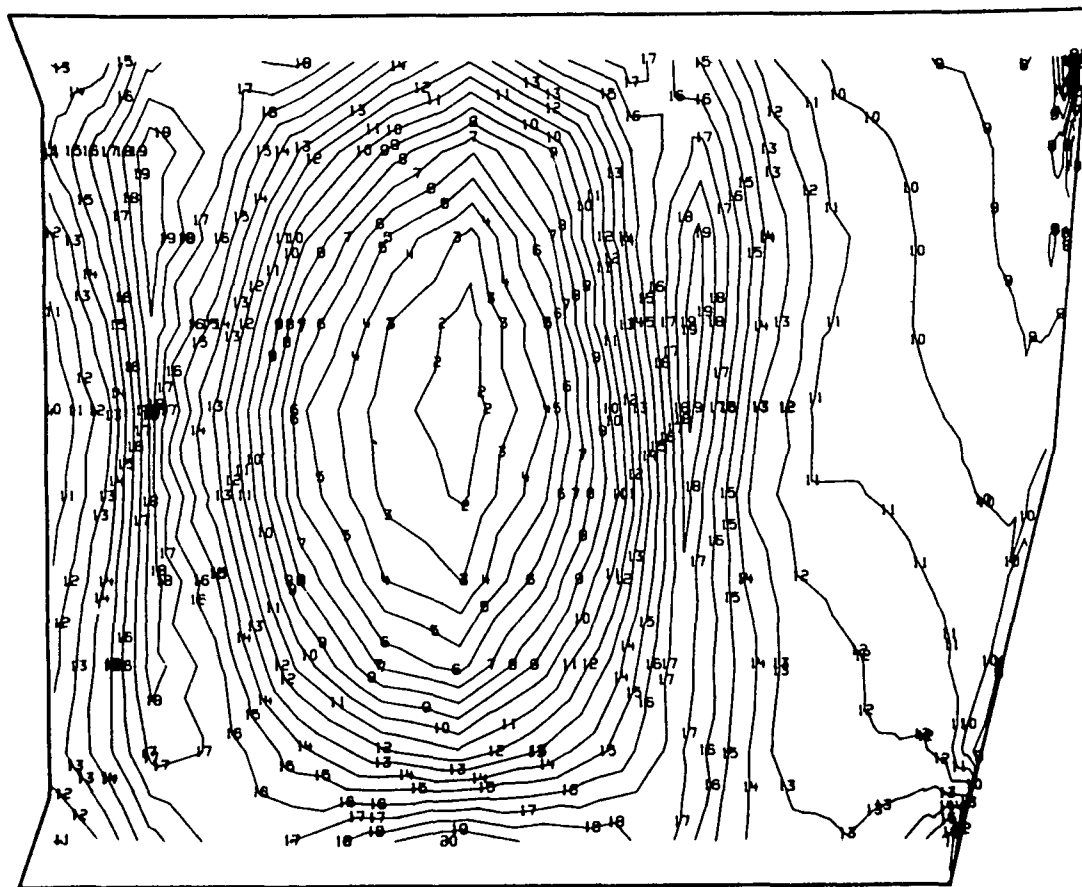
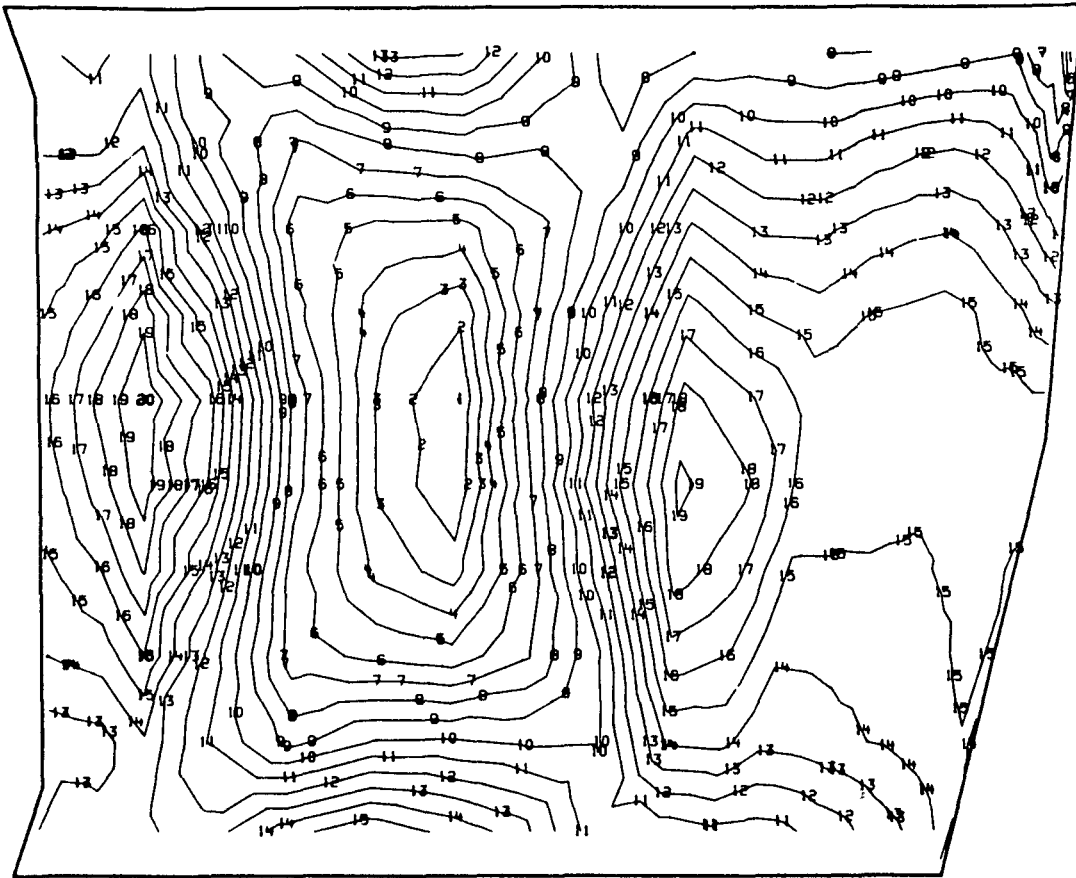

Fig. 3.2-23 Model F1, View 4, Airfoil Pressure Side



1	-3.329154E 04	11	6.322867E 03
2	-2.932910E 04	12	1.029530E 04
3	-2.536666E 04	13	1.425774E 04
4	-2.140422E 04	14	1.822018E 04
5	-1.744178E 04	15	2.218262E 04
6	-1.347934E 04	16	2.614505E 04
7	-9.516895E 03	17	3.010749E 04
8	-5.554493E 03	18	3.406993E 04
9	-1.592012E 03	19	3.803237E 04
10	2.370428E 03	20	4.199481E 04

Fig. 3.2-24 Model F1, FPL Load, View 4, Major Principal Stress (psi)



1	-5.382654E C4	11	-1.751C45E C4
2	-5.023492E C4	12	-1.431884E C4
3	-4.664322E C4	13	-1.072722E C4
4	-4.305171E C4	14	-7.135621E C3
5	-3.946011E C4	15	-3.544012E C3
6	-3.58685CE C4	16	4.759570E C1
7	-3.227689E C4	17	3.629204E C2
8	-2.868528E C4	18	7.22C813E C3
9	-2.509367E C4	19	1.082242E C4
10	-2.150206E C4	20	1.441407E C4

Fig. 3.2-25 Model F1, FPL Load, View 4, Minor Principal Stress (psi)

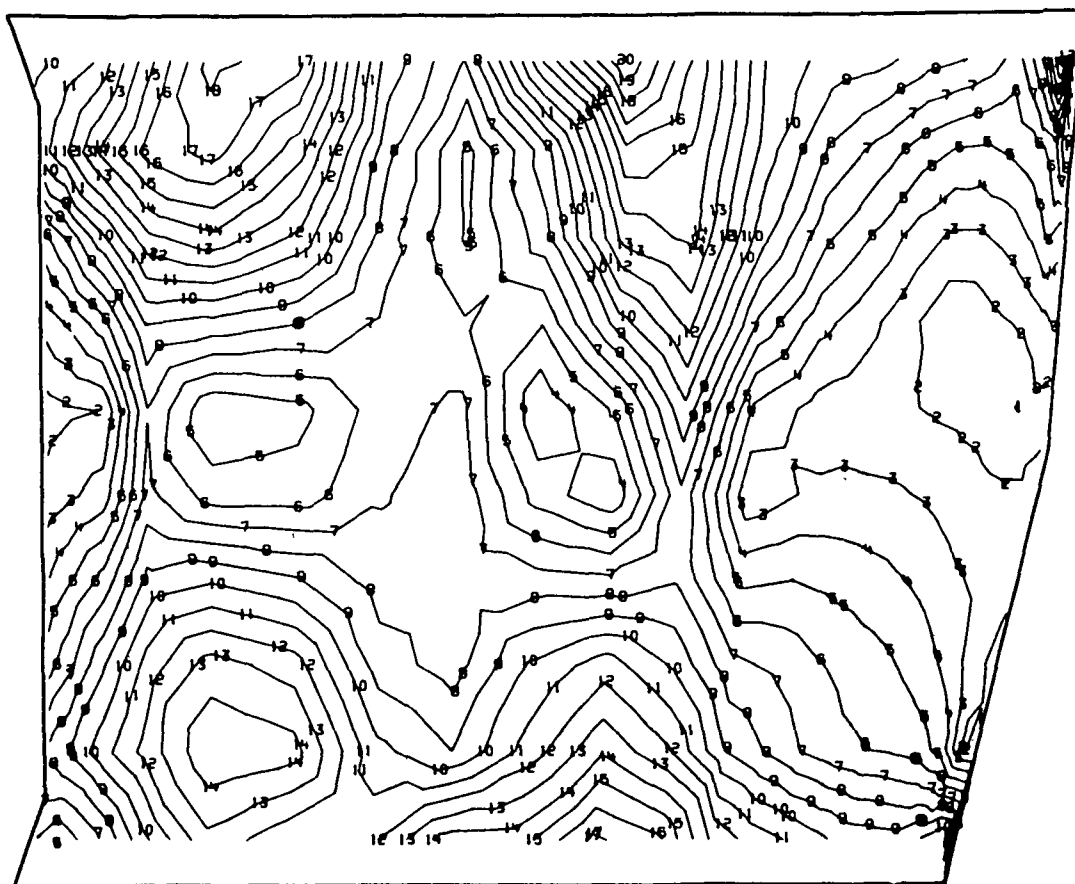

1	4.696907E C2	11	1.728043E C4
2	2.150766E C3	12	1.896151E 04
3	2.831842E 03	13	2.064258E C4
4	5.512914E C3	14	2.232366E 04
5	7.193988E 03	15	2.400473E C4
6	8.875063E C3	16	2.568580E 04
7	1.055614E C4	17	2.736688E 04
8	1.223721E 04	18	2.904795E 04
9	1.391829E C4	19	3.072903E C4
10	1.559936E C4	20	3.241013E C4

Fig. 3.2-26 Model F1, FPL Load, View 4, Maximum Principal Shear (psi)

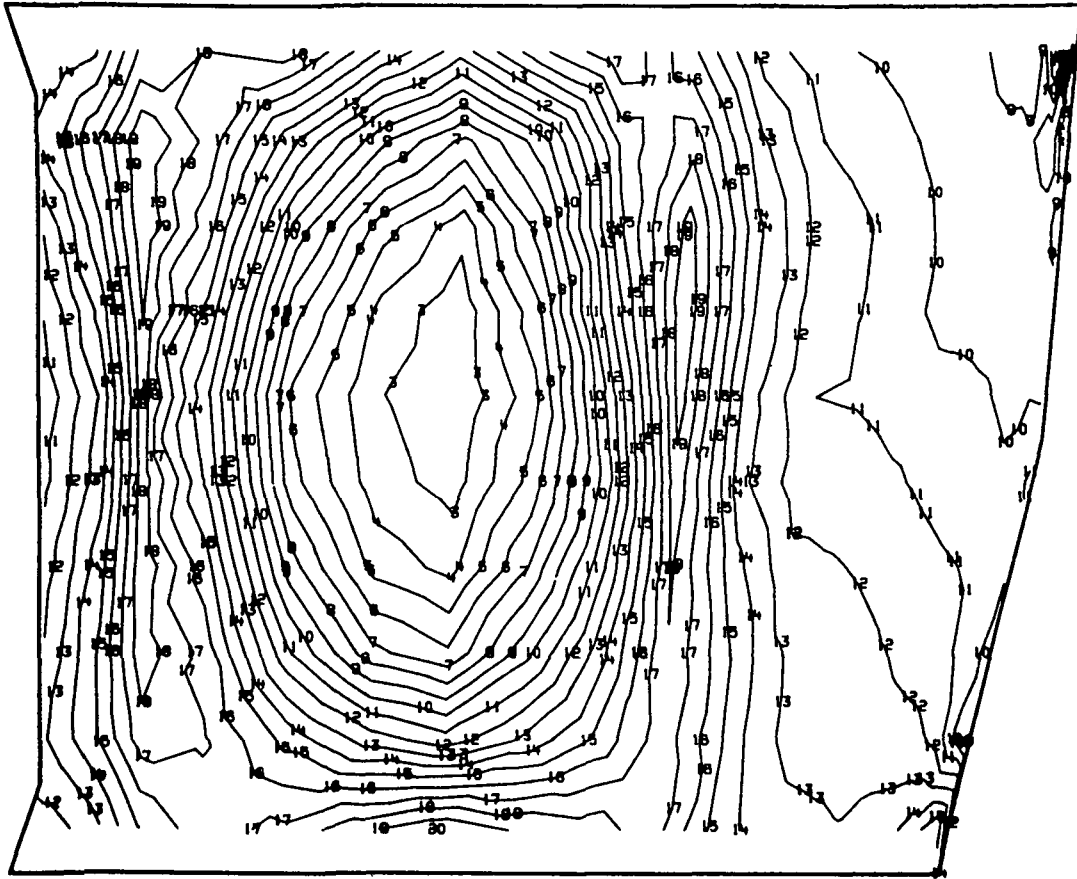

1	-3.700011E 04	11	4.245668E 03
2	-3.287554E 04	12	8.370246E 03
3	-2.875096E 04	13	1.245492E 04
4	-2.462638E 04	14	1.661940E 04
5	-2.050180E 04	15	2.074398E 04
6	-1.637722E 04	16	2.486856E 04
7	-1.225264E 04	17	2.899314E 04
8	-8.128066E 03	18	3.311771E 04
9	-4.003488E 03	19	3.724229E 04
10	1.210898E 02	20	4.136692E 04

Fig. 3.2-27 Model F1, 115% Load, View 4, Major Principal Stress (psi)

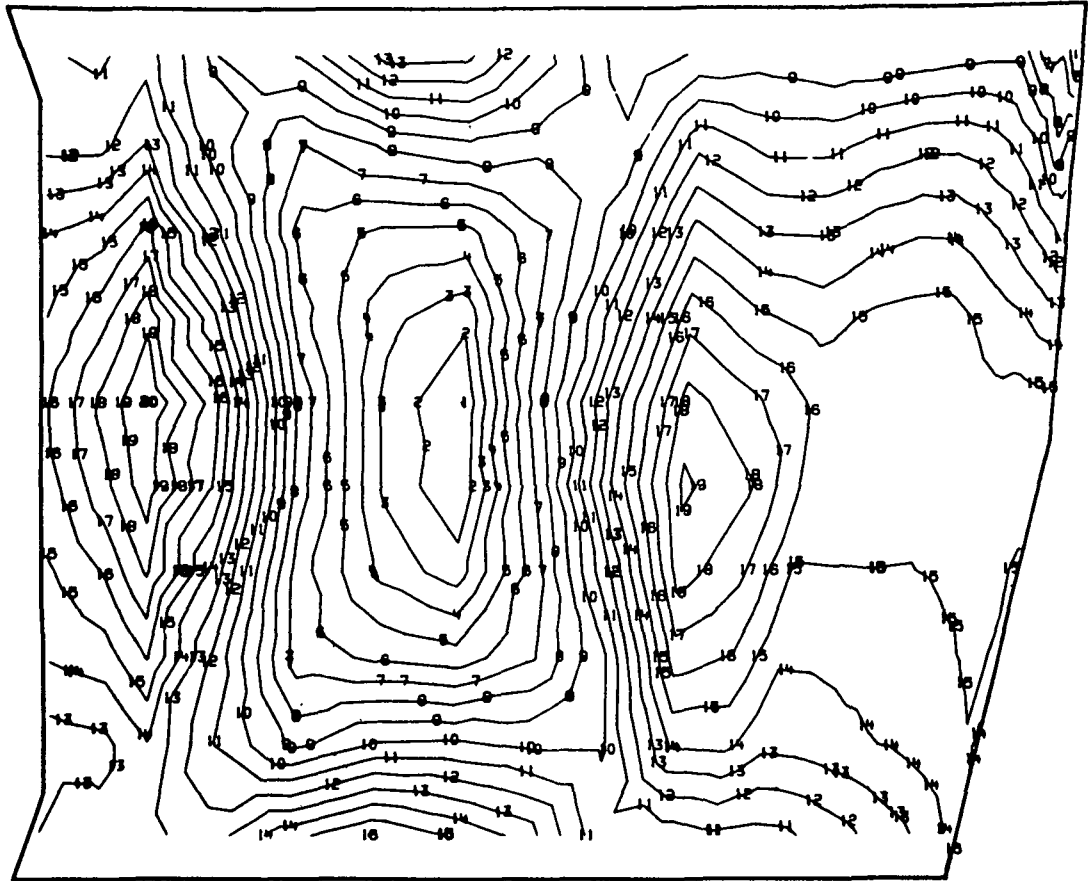

1	-5.397547E 04	11	-1.830680E 04
2	-5.040860E 04	12	-1.473993E 04
3	-4.684173E 04	13	-1.117306E 04
4	-4.327487E 04	14	-7.606195E 03
5	-3.970800E 04	15	-4.039330E 03
6	-3.614113E 04	16	-4.724653E 02
7	-3.257427E 04	17	3.094400E 03
8	-2.900740E 04	18	6.661262E 03
9	-2.544053E 04	19	1.022813E 04
10	-2.187366E 04	20	1.379498E 04

Fig. 3.2-28 Model F1, 115% Load, View 4, Minor Principal Stress (psi)

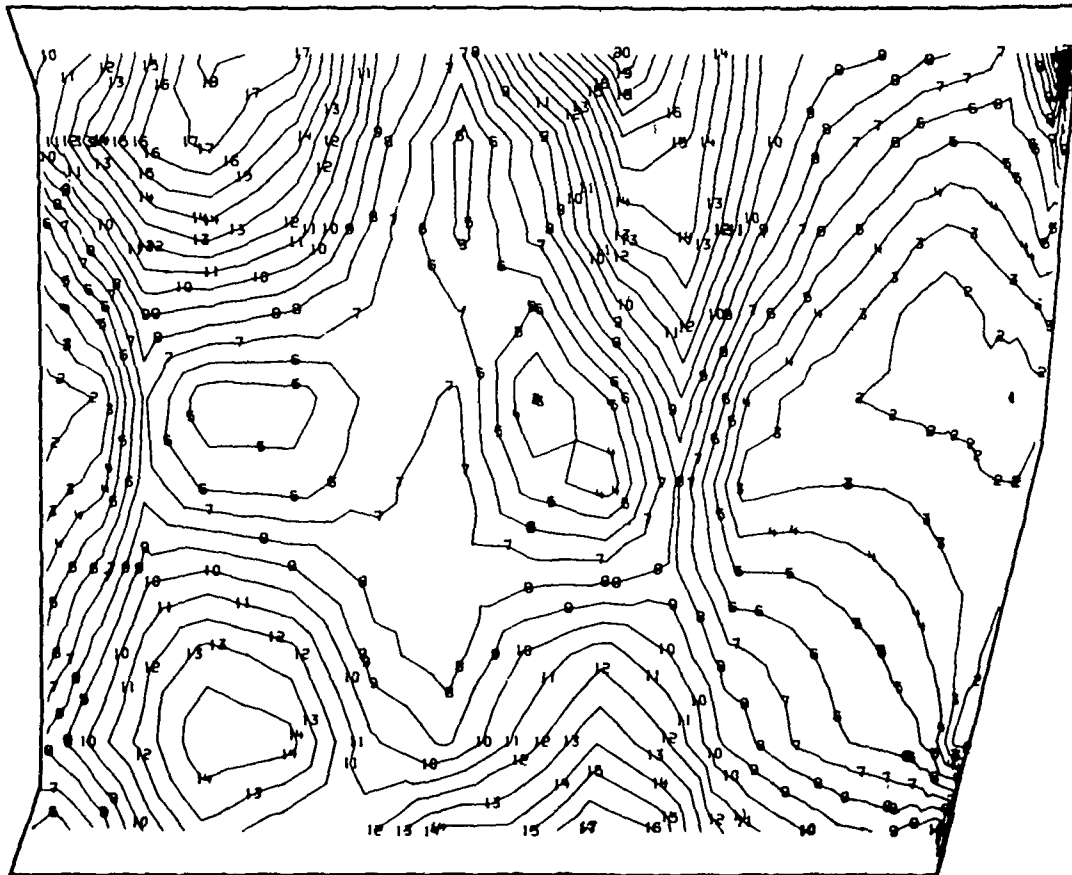

1	6.121838E 02	11	1.722796E 04
2	2.274762E 03	12	1.890054E 04
3	3.937340E 03	13	2.056312E 04
4	5.599918E 03	14	2.222570E 04
5	7.262496E 03	15	2.388328E 04
6	8.925074E 03	16	2.555086E 04
7	1.058765E 04	17	2.721343E 04
8	1.225023E 04	18	2.887601E 04
9	1.391281E 04	19	3.053859E 04
10	1.557539E 04	20	3.220117E 04

Fig. 3.2-29 Model F1, 115% Load, View 4, Maximum Principal Shear (psi)

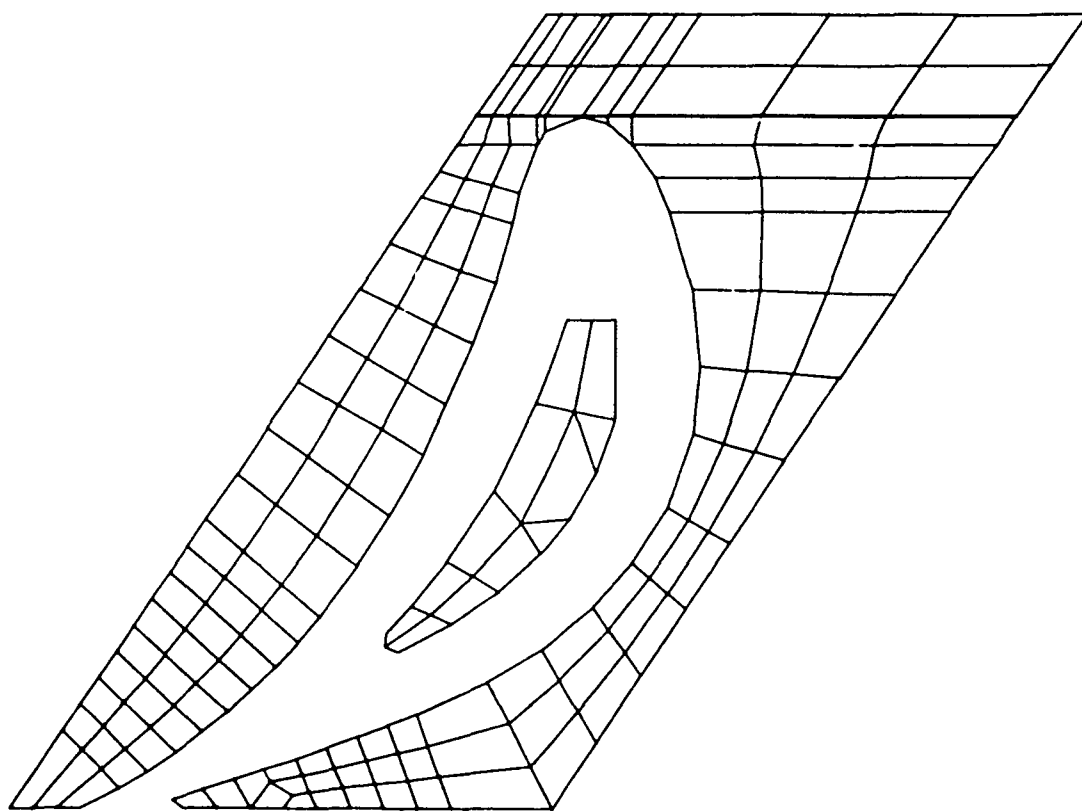
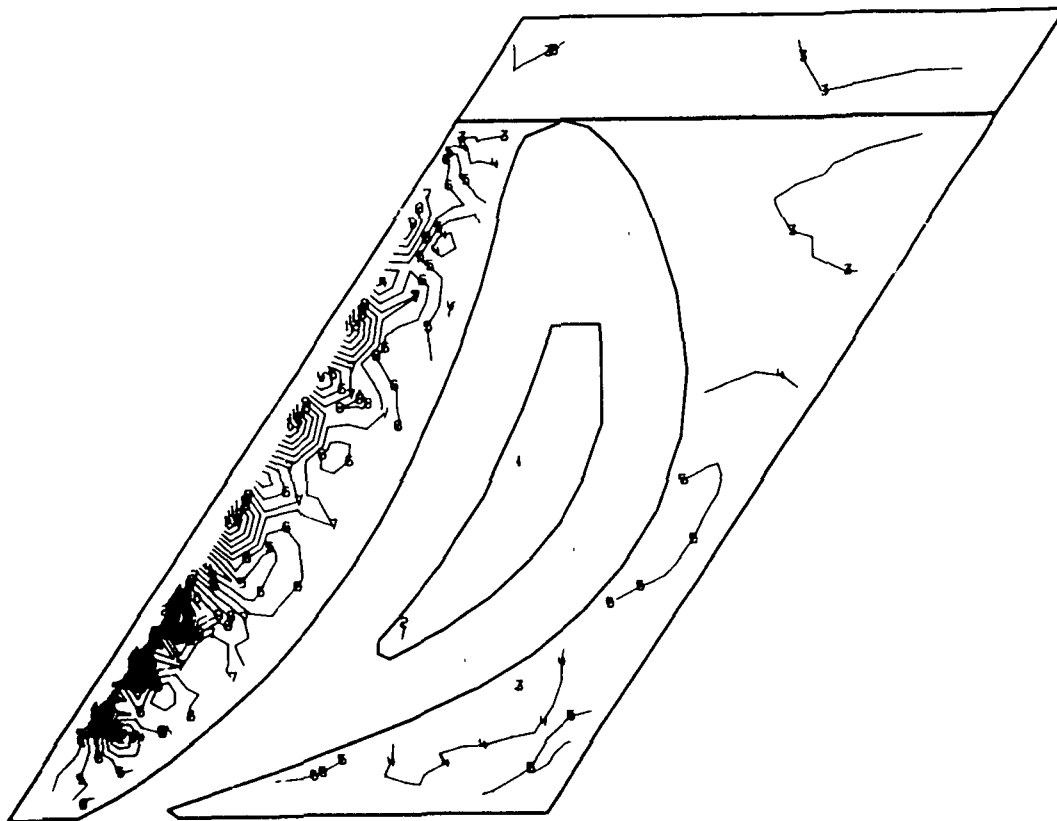
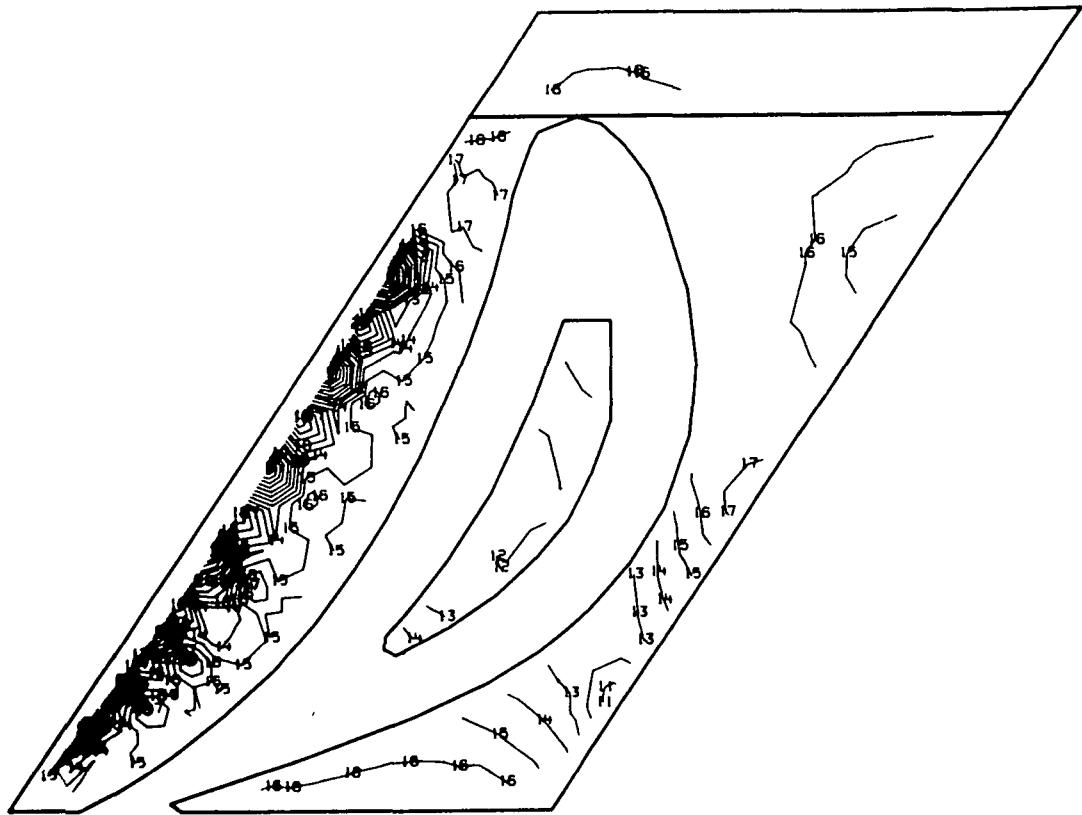

Fig. 3.2-30 Model F1, View 5, Hub Outer Surface



1	-6.711000E C3	11	7.546250E 04
2	1.500359E C3	12	8.367981E C4
3	9.723719E C3	13	9.189713E 04
4	1.794108E C4	14	1.001144E C5
5	2.615844E C4	15	1.083318E 05
6	3.437580E C4	16	1.165491E C5
7	4.259216E C4	17	1.247664E C5
8	5.081052E C4	18	1.329837E C5
9	5.902788E C4	19	1.412010E C5
10	6.724519E 04	20	1.494189E C5

Fig. 3.2-31 Model F1, FPL Load, View 5, Major Principal Stress (psi)



1	-1.541253E C5	11	-5.404970E C4
2	-1.441268E C5	12	-4.404115E C4
3	-1.341182E C5	13	-3.403259E C4
4	-1.241096E C5	14	-2.402404E C4
5	-1.141011E C5	15	-1.401548E C4
6	-1.040925E C5	16	-4.006930E C3
7	-9.403394E C4	17	6.001625E C3
8	-8.407538E C4	18	1.601018E C4
9	-7.406681E C4	19	2.601873E C4
10	-6.405826E C4	20	3.602728E C4

Fig. 3.2-32 Model F1, FPL Load, View 5, Minor Principal Stress (psi)

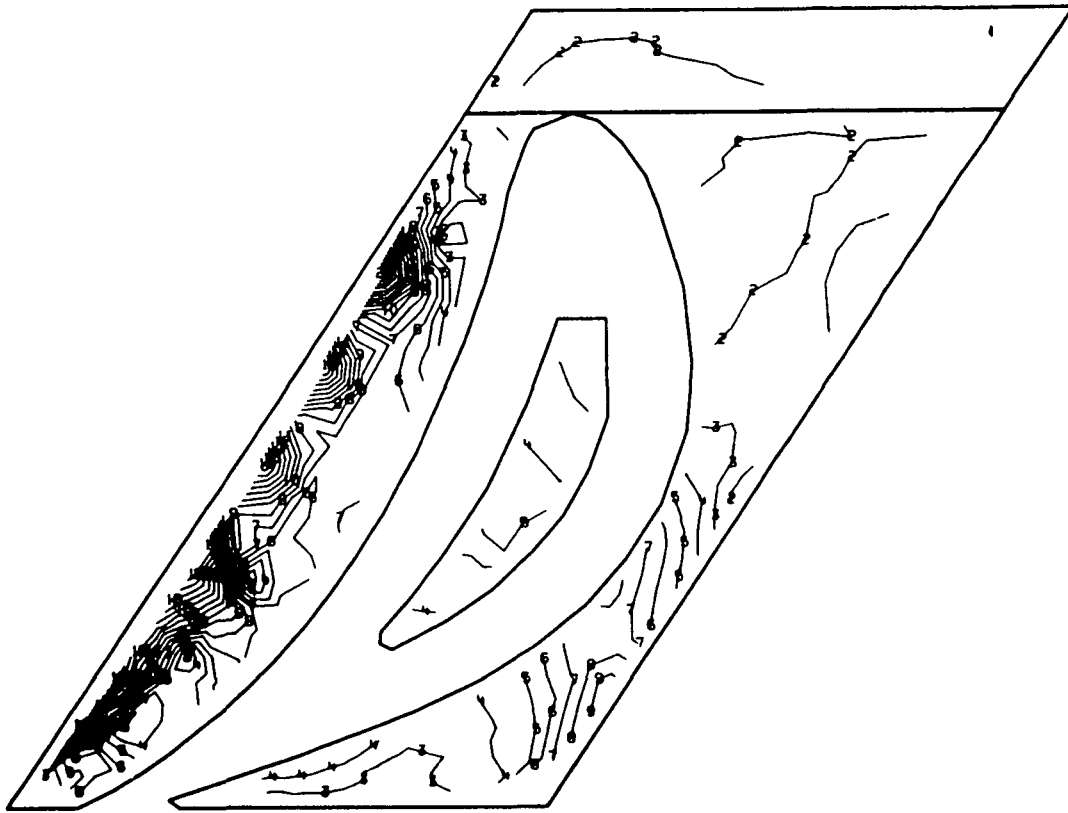

1	2.511820E C3	11	4.543629E C4
2	6.804277E C3	12	4.972885E 04
3	1.109673E 04	13	5.402130E C4
4	1.538919E C4	14	5.831376E 04
5	1.968165E C4	15	6.260622E C4
6	2.397411E 04	16	6.689863E 04
7	2.826656E C4	17	7.119106E 04
8	3.255902E C4	18	7.548350E C4
9	3.685148E 04	19	7.977594E 04
10	4.114393E 04	20	8.406863E 04

Fig. 3.2-33 Model F1, FPL Load, View 5, Maximum Principal Shear (psi)

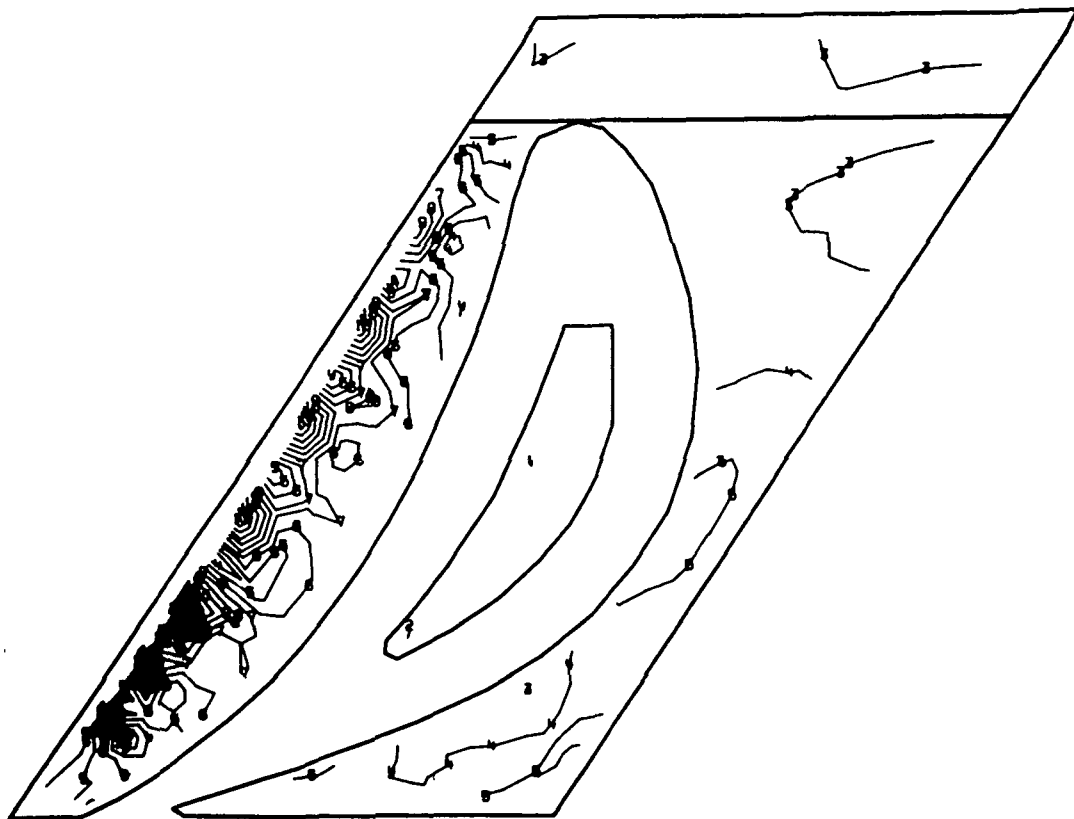

1	-7.171316E 03	11	7.332531E 04
2	8.783516E 02	12	8.137494E 04
3	8.928020E 03	13	8.942456E 04
4	1.697769E 04	14	9.747419E 04
5	2.502736E 04	15	1.055238E 05
6	3.307702E 04	16	1.135734E 05
7	4.112669E 04	17	1.216231E 05
8	4.917636E 04	18	1.296727E 05
9	5.722603E 04	19	1.377223E 05
10	6.527570E 04	20	1.457724E 05

Fig. 3.2-34 Model F1, 115% Load, View 5, Major Principal Stress (psi)

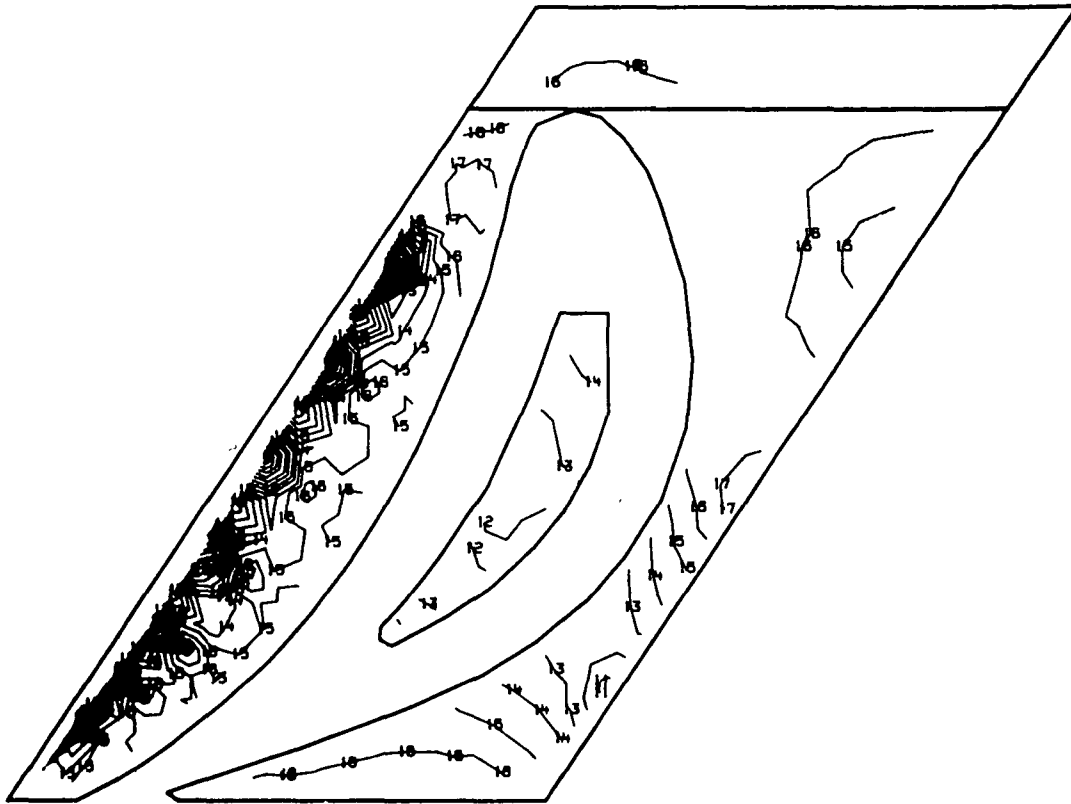

1	-1.490798E 05	11	-5.215859E 04
2	-1.393877E 05	12	-4.246647E 04
3	-1.296956E 05	13	-3.277436E 04
4	-1.200034E 05	14	-2.308225E 04
5	-1.103113E 05	15	-1.339013E 04
6	-1.006192E 05	16	-3.698020E 03
7	-9.092706E 04	17	5.994094E 03
8	-8.123494E 04	18	1.568621E 04
9	-7.154281E 04	19	2.537832E 04
10	-6.185070E 04	20	3.507042E 04

Fig. 3.2-35 Model F1, 115% Load, View 5, Minor Principal Stress (psi)

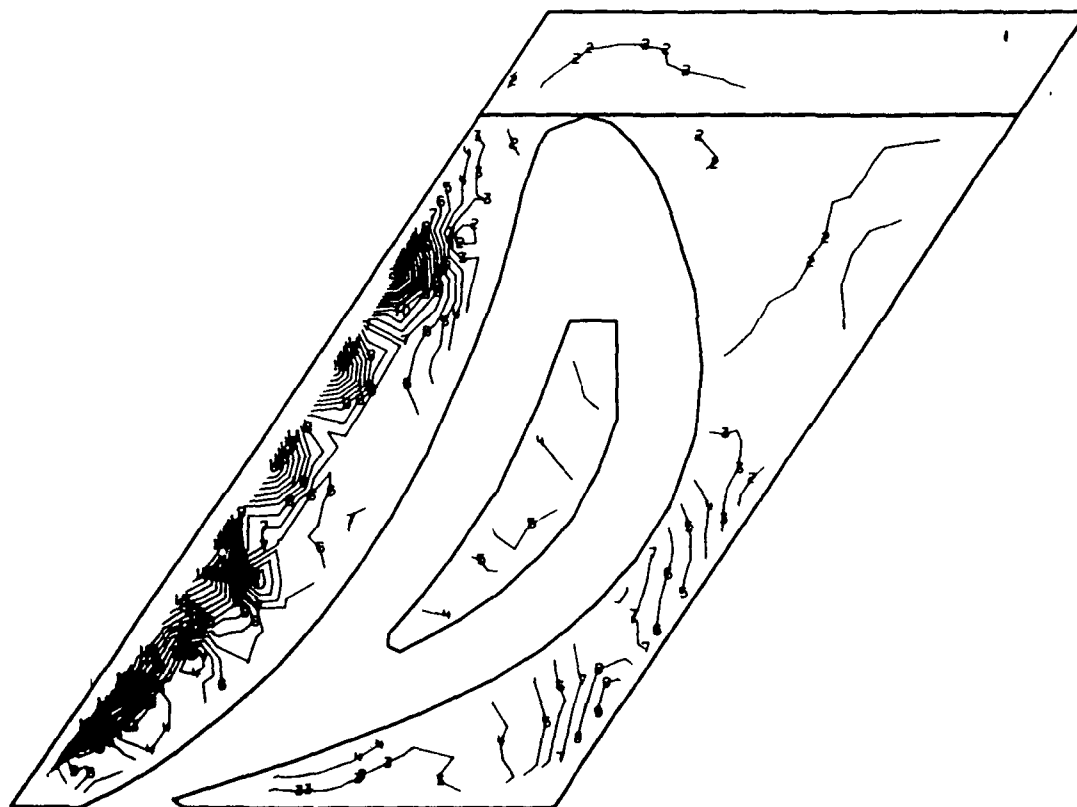

1	2.586000E 03	11	4.391987E 04
2	6.709387E 03	12	4.794325E 04
3	1.083277E 04	13	5.206664E 04
4	1.495616E 04	14	5.619003E 04
5	1.907955E 04	15	6.031341E 04
6	2.320293E 04	16	6.442680E 04
7	2.732632E 04	17	6.856019E 04
8	3.144971E 04	18	7.268356E 04
9	3.557309E 04	19	7.680694E 04
10	3.969648E 04	20	8.093038E 04

Fig. 3.2-36 Model F1, 115% Load, View 5, Maximum Principal Shear (psi)

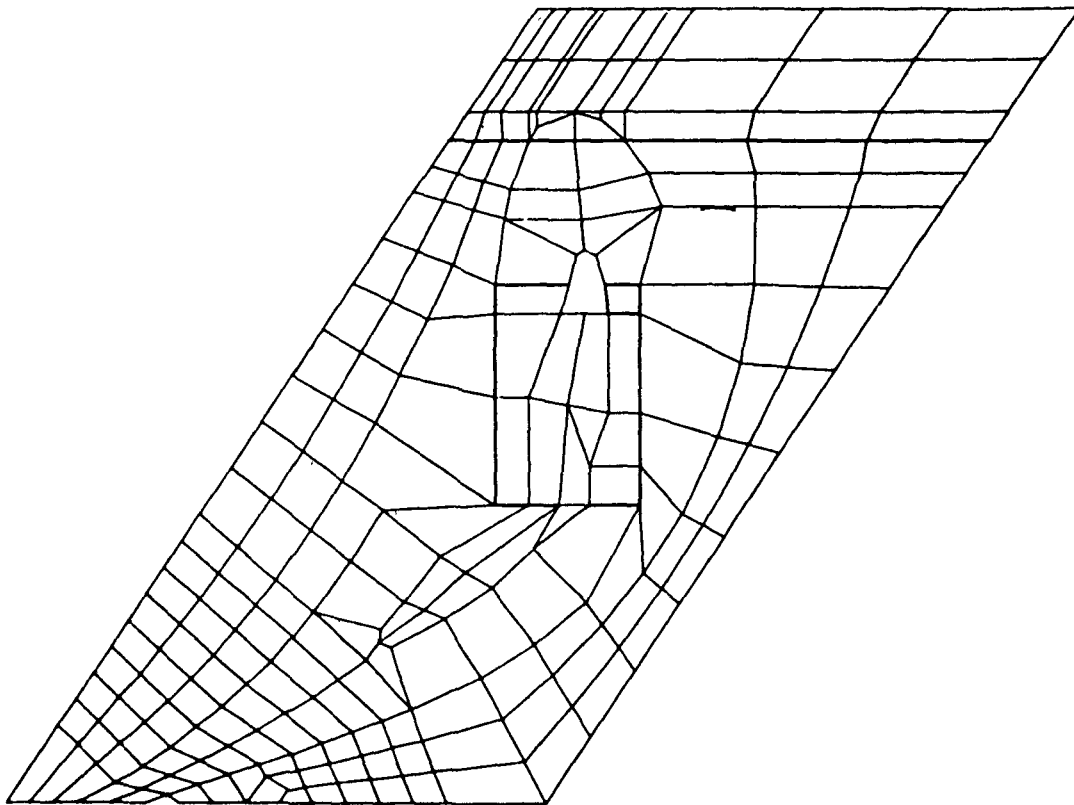
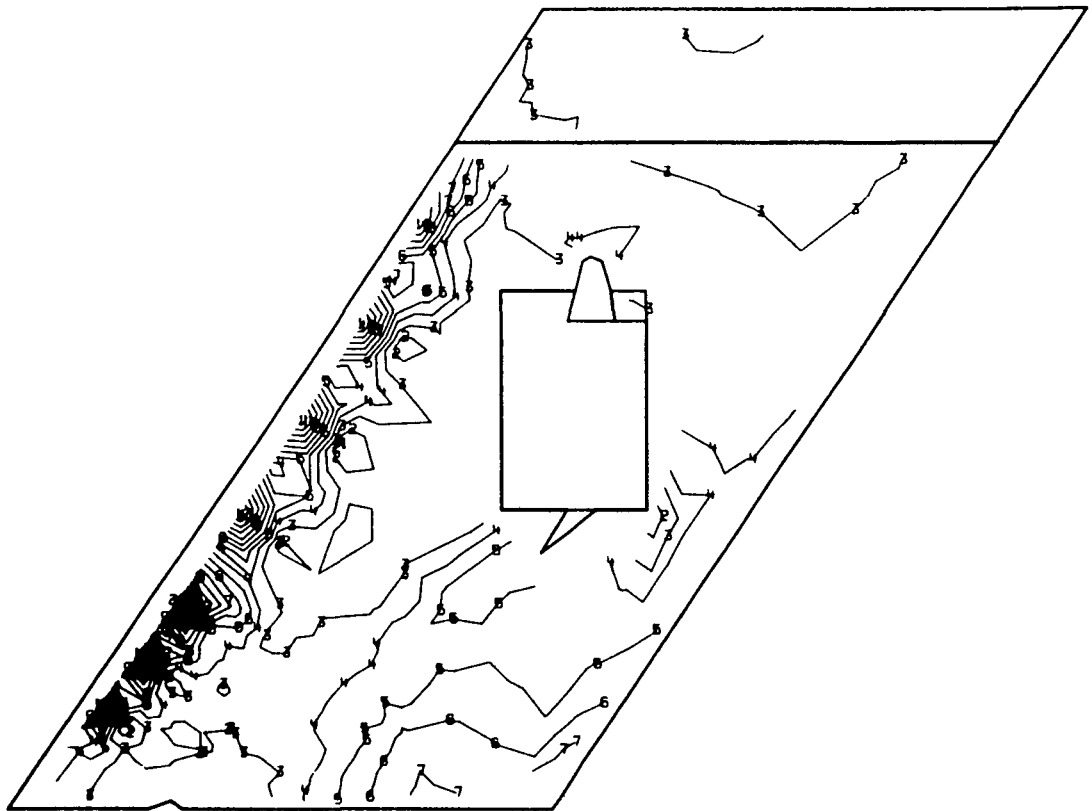
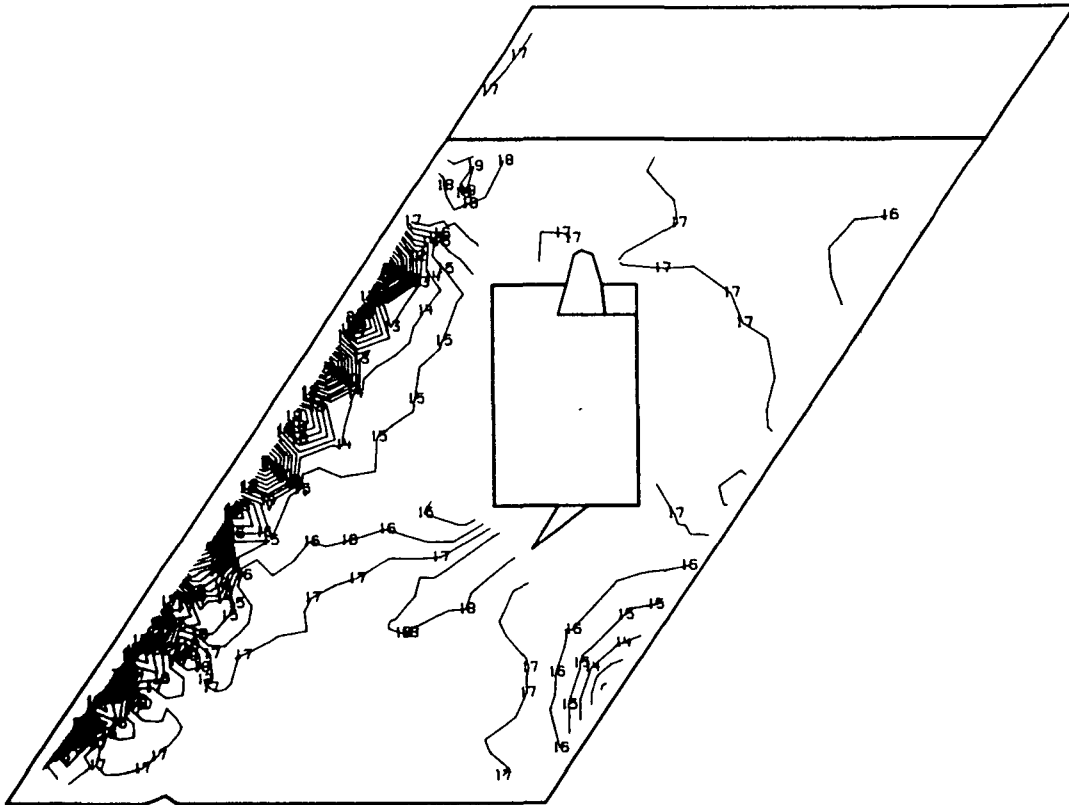

Fig. 3.2-37 Model F1, View 6, Hub Inner Surface



1	-5.532324E 03	11	7.731531E 04
2	2.752445E C3	12	8.560006E 04
3	1.103721E C4	13	9.388481E C4
4	1.932198E 04	14	1.021696E C5
5	2.760675E C4	15	1.104542E 05
6	3.589152E C4	16	1.187291E C5
7	4.417629E 04	17	1.270238E 05
8	5.246106E C4	18	1.353086E C5
9	6.074582E C4	19	1.435923E C5
10	6.903056E C4	20	1.518784E C5

Fig. 3.2-38 Model F1, FPL Load, View 6, Major Principal Stress (psi)



1	-1.621888E C5	11	-6.304679E C4
2	-1.522744E C5	12	-5.213263E C4
3	-1.423603E C5	13	-4.221846E C4
4	-1.324461E C5	14	-3.230433E C4
5	-1.225219E C5	15	-2.239018E C4
6	-1.126177E C5	16	-1.247602E C4
7	-1.027025E C5	17	-2.561871E C2
8	-9.278921E C4	18	6.252281E C3
9	-8.287513E C4	19	1.626643E C4
10	-7.296094E C4	20	2.618036E C4

Fig. 3.2-39 Model F1, FPL Load, View 6, Minor Principal Stress (psi)

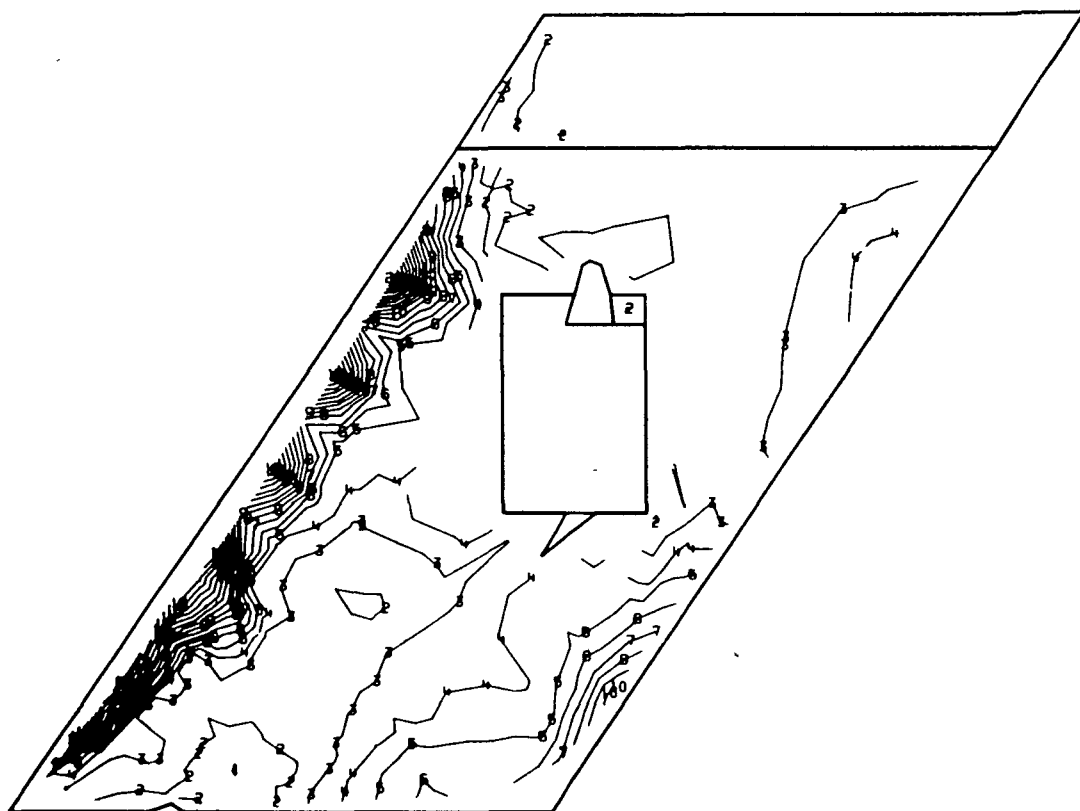

1	1.824993E 02	11	4.674275E 04
2	4.829422E 03	12	5.139868E 04
3	5.455248E 03	13	5.605461E 04
4	1.415127E 04	14	6.071053E 04
5	1.880720E 04	15	6.536646E 04
6	2.346213E 04	16	7.002238E 04
7	2.811905E 04	17	7.467825E 04
8	3.277498E 04	18	7.933413E 04
9	3.743090E 04	19	8.399000E 04
10	4.208683E 04	20	8.864613E 04

Fig. 3.2-40 Model F1, FPL Load, View 6, Maximum Principal Shear (psi)

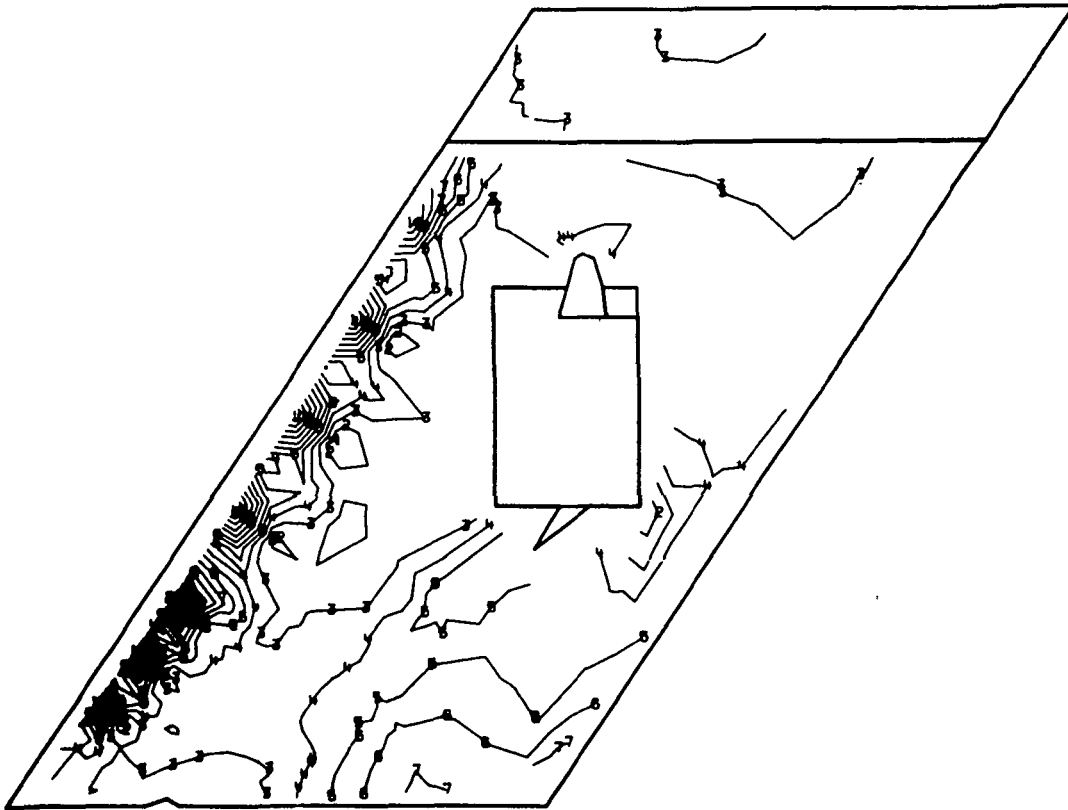

1	-5.986371E 03	11	7.468019E 04
2	2.080289E 03	12	8.274681E 04
3	1.014695E 04	13	9.081344E 04
4	1.821361E 04	14	9.888006E 04
5	2.628027E 04	15	1.069467E 05
6	3.434693E 04	16	1.150133E 05
7	4.241359E 04	17	1.230799E 05
8	5.048025E 04	18	1.311466E 05
9	5.854691E 04	19	1.392132E 05
10	6.661356E 04	20	1.472803E 05

Fig. 3.2-41 Model F1, 115% Load, View 6, Major Principal Stress (psi)

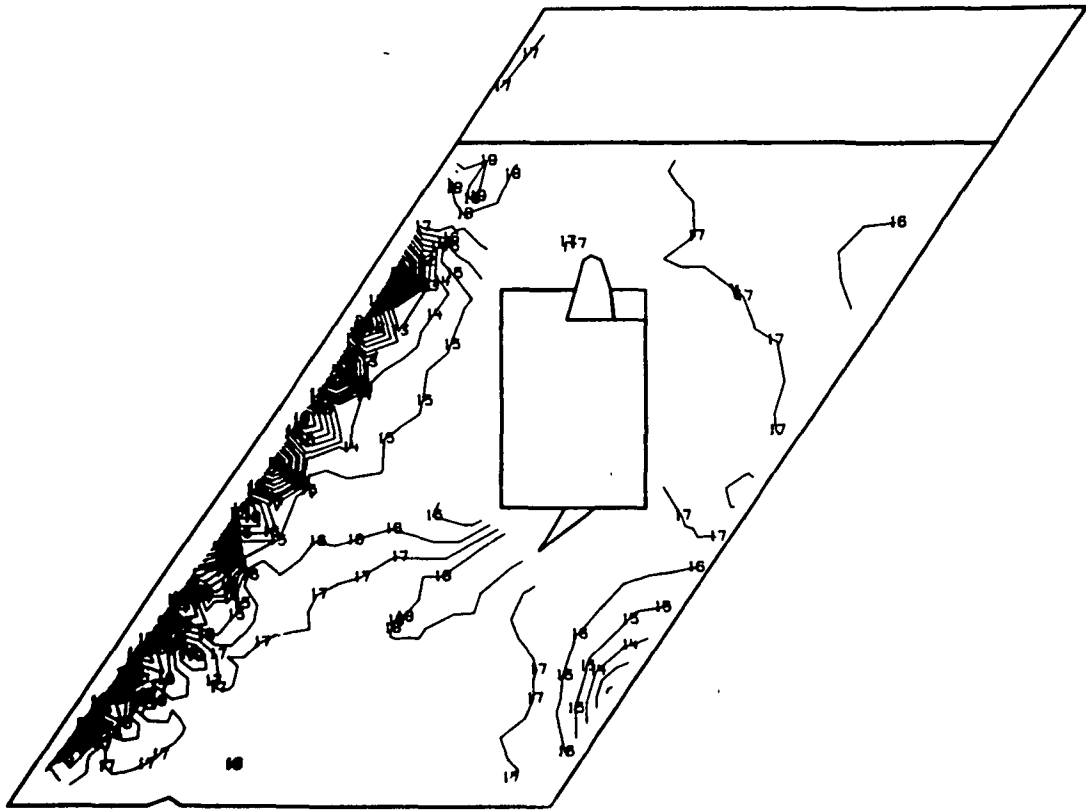

1	-1.570506E 05	11	-6.116303E 04
2	-1.474623E 05	12	-5.157985E 04
3	-1.378741E 05	13	-4.199162E 04
4	-1.282858E 05	14	-3.240339E 04
5	-1.186976E 05	15	-2.281516E 04
6	-1.091093E 05	16	-1.322693E 04
7	-9.952106E 04	17	-3.638659E 03
8	-8.993281E 04	18	5.949531E 03
9	-8.034456E 04	19	1.553776E 04
10	-7.075631E 04	20	2.512588E 04

Fig. 3.2-42 Model F1, 115% Load, View 6, Minor Principal Stress (psi)

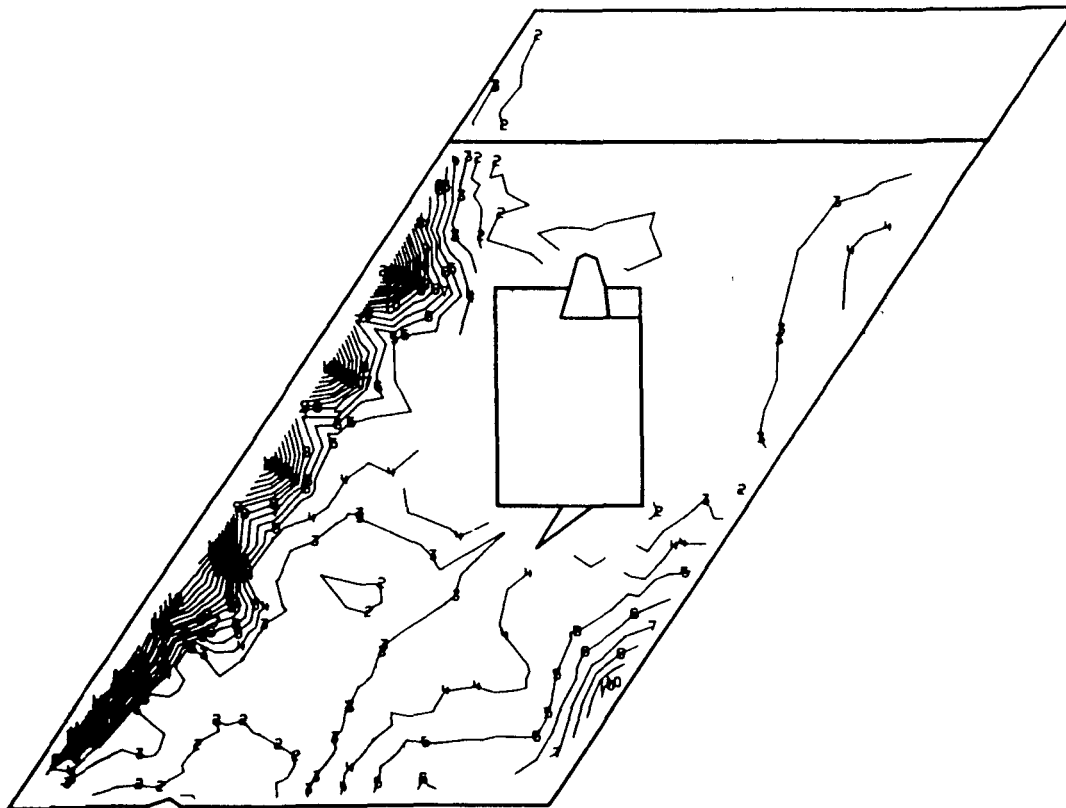

1	2.075697E 02	11	4.498772E 04
2	4.685582E 03	12	4.946574E 04
3	9.163598E 03	13	5.394375E 04
4	1.364161E 04	14	5.842177E 04
5	1.811963E 04	15	6.289979E 04
6	2.259764E 04	16	6.737775E 04
7	2.707566E 04	17	7.185575E 04
8	3.155368E 04	18	7.633375E 04
9	3.603169E 04	19	8.081175E 04
10	4.050971E 04	20	8.528994E 04

Fig. 3.2-43 Model F1, 115% Load, View 6, Maximum Principal Shear (psi)

3.3 HPFTP SECOND STAGE NOZZLES STRESSES AT FPL AND 115% RPL

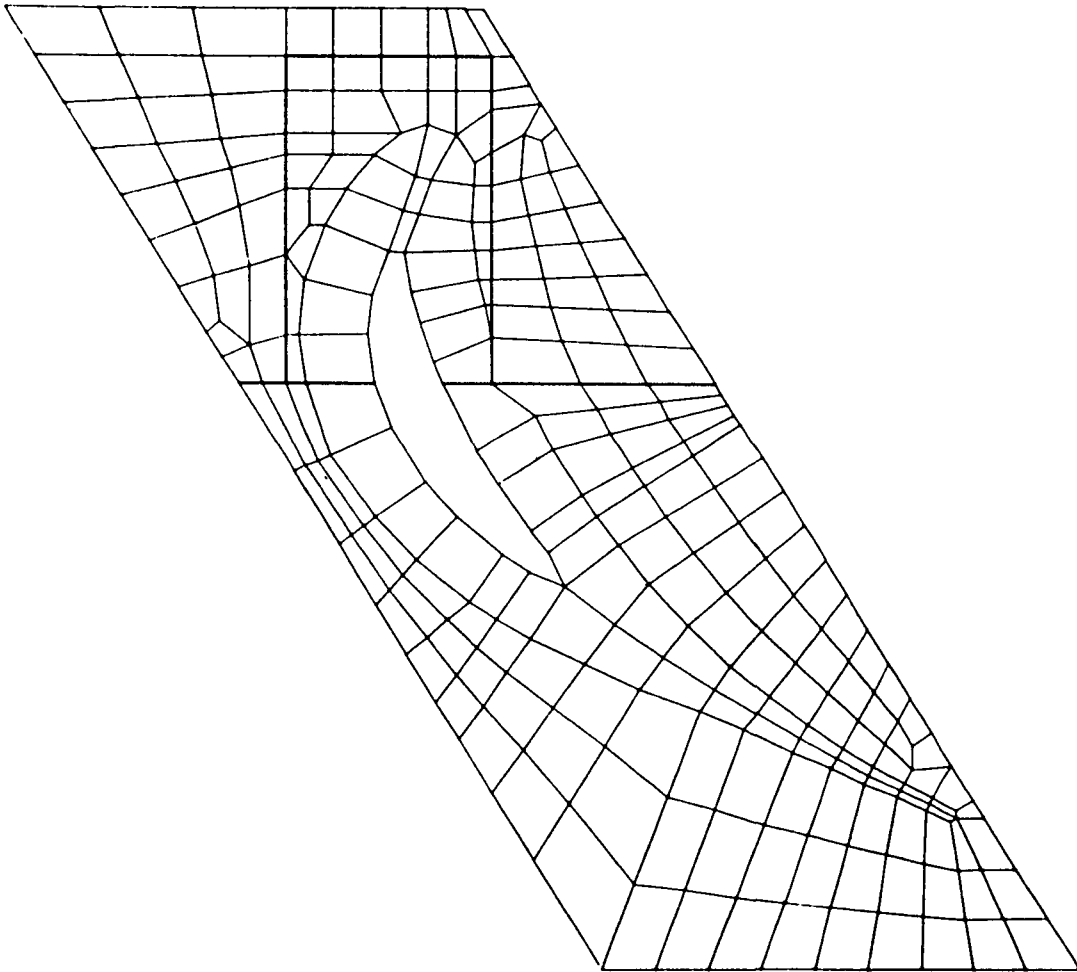
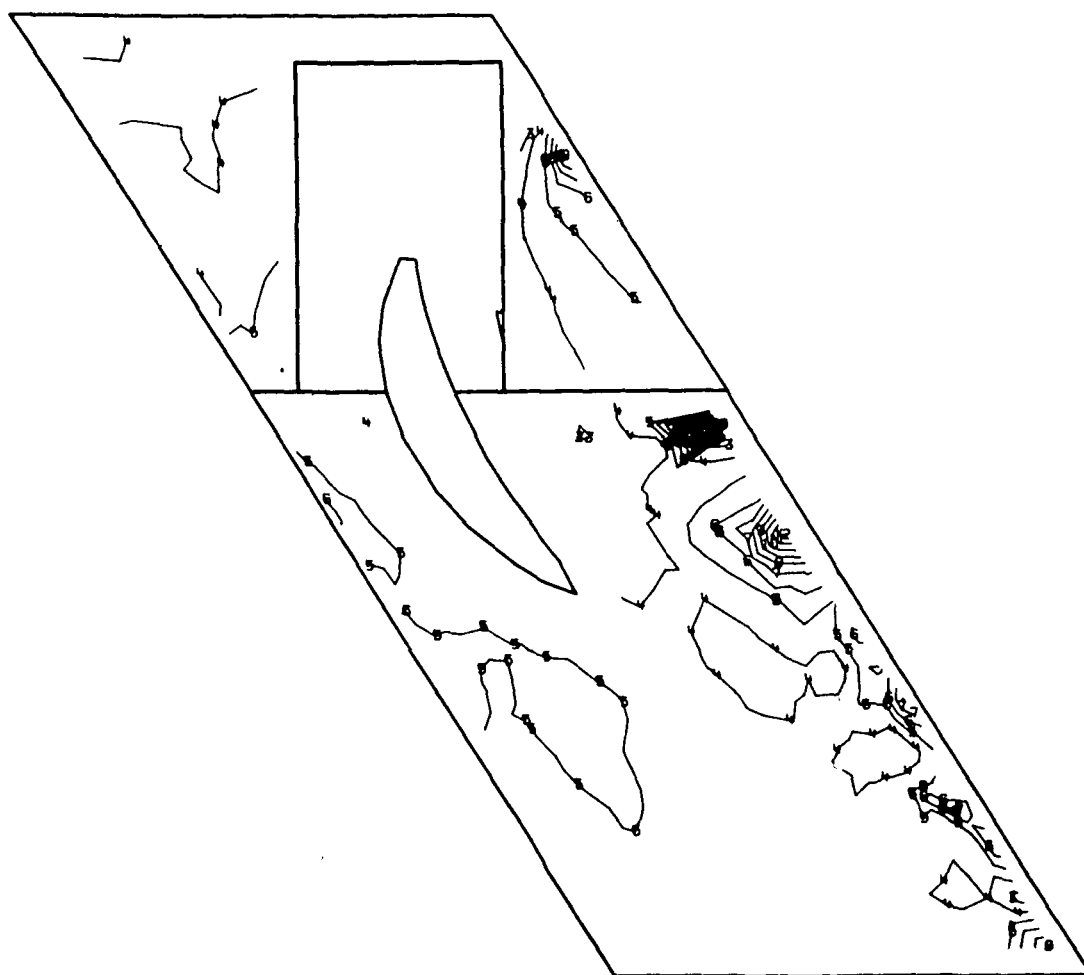
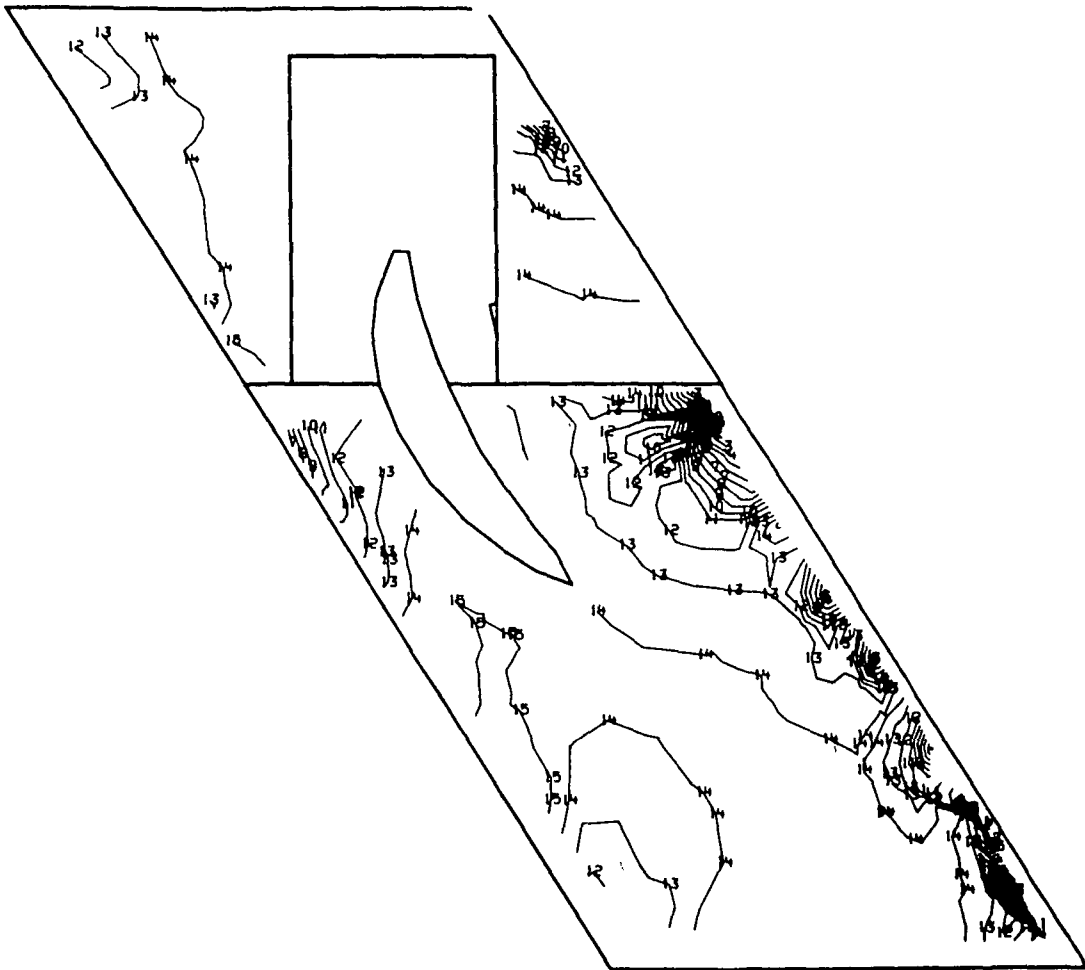

Fig. 3.3-1 Model F2, View 1, Shroud Outside Surface



1	-4.01704E 04	11	1.400346E 05
2	-3.024996E 04	12	1.589551E 05
3	-1.132944E 04	13	1.778756E 05
4	7.591078E 03	14	1.967901E 05
5	2.651160E 04	15	2.157166E 05
6	4.543212E 04	16	2.346371E 05
7	6.435264E 04	17	2.535576E 05
8	8.327313E 04	18	2.724731E 05
9	1.021936E 05	19	2.913986E 05
10	1.211141E 05	20	3.103195E 05

Fig. 3.3-2 Model F2, View 1, FPL Load, Major Principal Stress (psi)



1	-1.674520E 05	05	11	-4.371996E 04
2	-1.550797E 05	05	12	-3.134669E 04
3	-1.427064E 05	05	13	-1.897342E 04
4	-1.303331E 05	05	14	-6.600152E 03
5	-1.179598E 05	05	15	5.773117E 03
6	-1.055864E 05	05	16	1.814639E 04
7	-9.321313E 04	04	17	3.051966E 04
8	-8.083981E 04	04	18	4.289293E 04
9	-6.846650E 04	04	19	5.526620E 04
10	-5.609323E 04	04	20	6.763913E 04

Fig. 3.3-3 Model F2, View 1, FPL Load, Minor Principal Stress (psi)

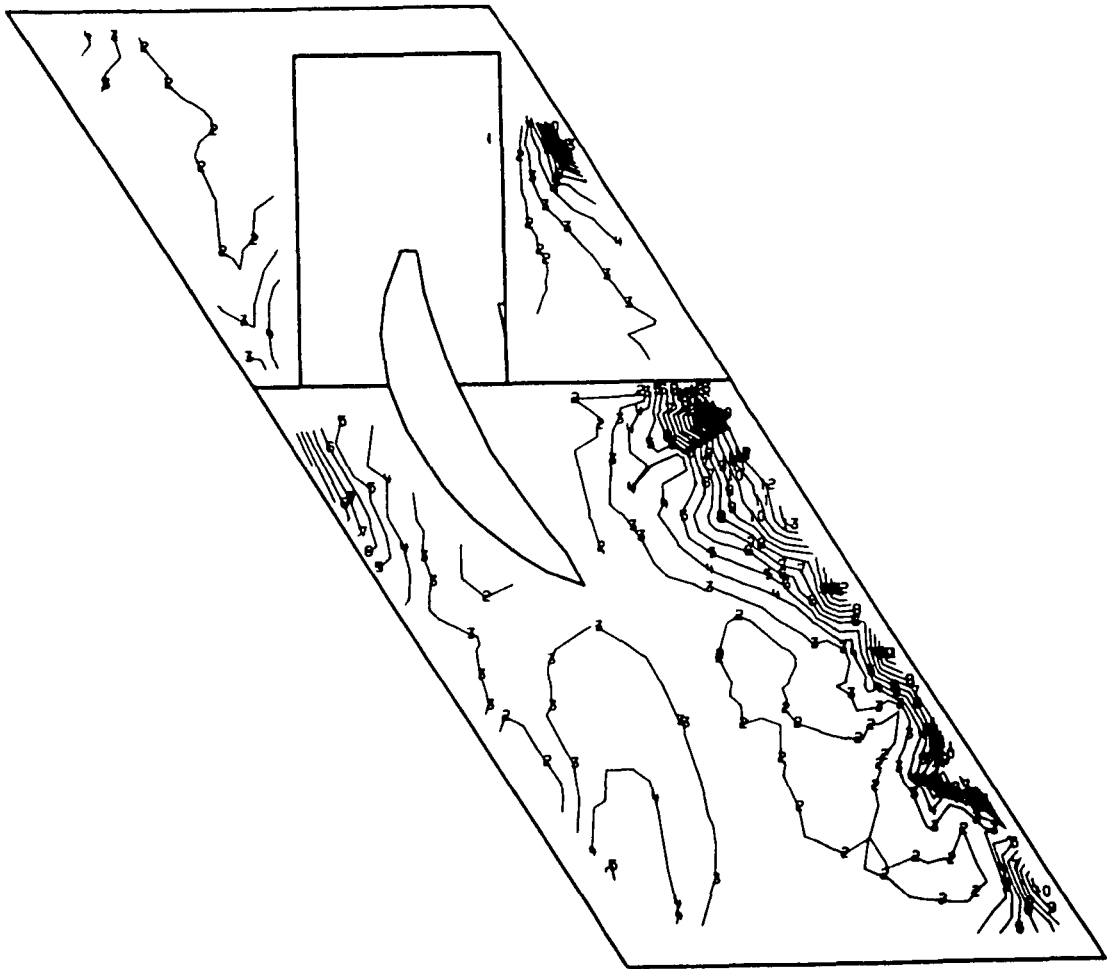

1	3.258528E 02	11	6.401757E 04
2	6.695023E 03	12	7.038669E 04
3	1.306420E 04	13	7.675581E 04
4	1.943337E 04	14	8.312494E 04
5	2.580254E 04	15	8.949406E 04
6	3.217171E 04	16	9.586319E 04
7	3.854088E 04	17	1.022323E 05
8	4.491005E 04	18	1.086014E 05
9	5.127923E 04	19	1.149706E 05
10	5.764840E 04	20	1.213402E 05

Fig. 3.3-4 Model F2, View 1, FPL Load, Shear Maximum Stress (psi)

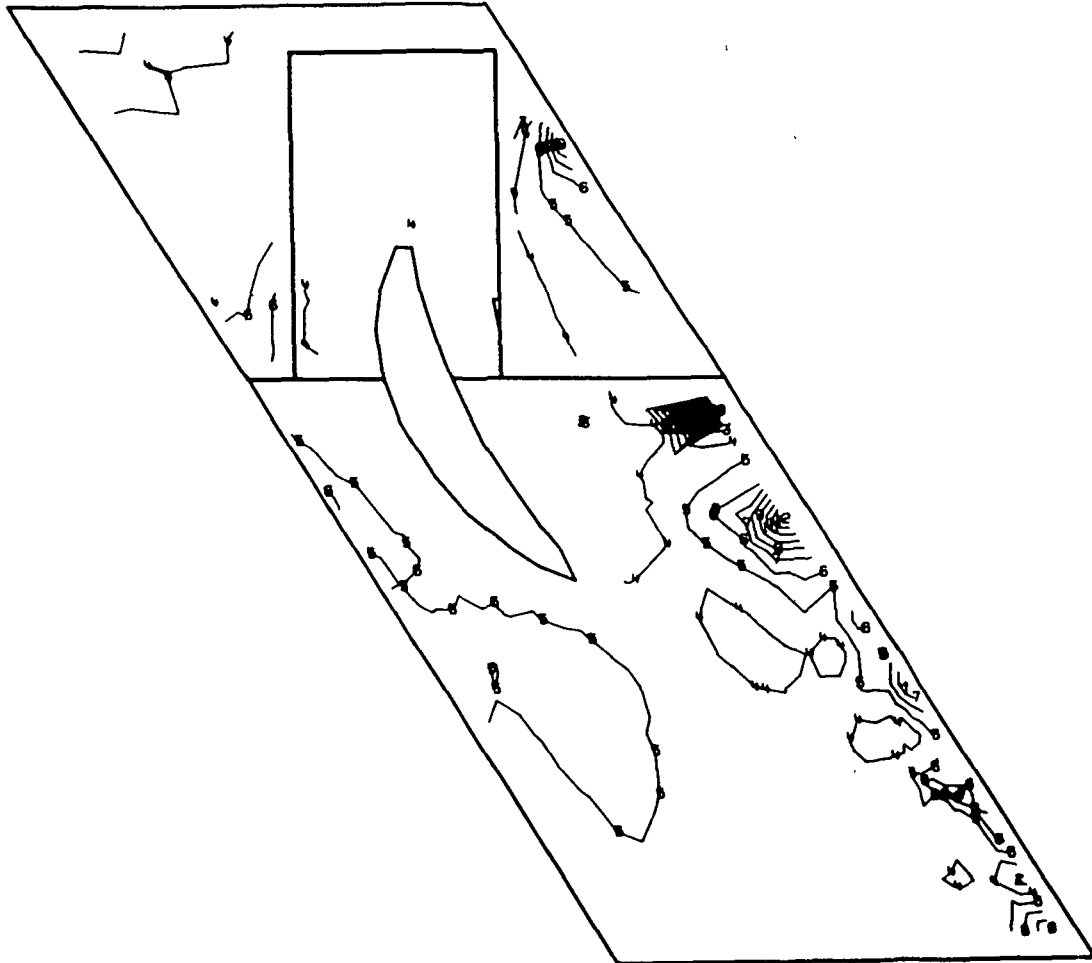

1	-4.994523E C4	11	1.375956E C5
2	-3.119113E C4	12	1.563497E C5
3	-1.243703E C4	13	1.751038E C5
4	6.317074E C3	14	1.938578E C5
5	2.507118E C4	15	2.126119E C5
6	4.382528E C4	16	2.313659E C5
7	6.257938E C4	17	2.501200E C5
8	8.133344E C4	18	2.688741E C5
9	1.000875E C5	19	2.876281E C5
10	1.188416E C5	20	2.063828E C5

Fig. 3.3-5 Model F2, View 1, 115% Load, Major Principal Stress (psi)

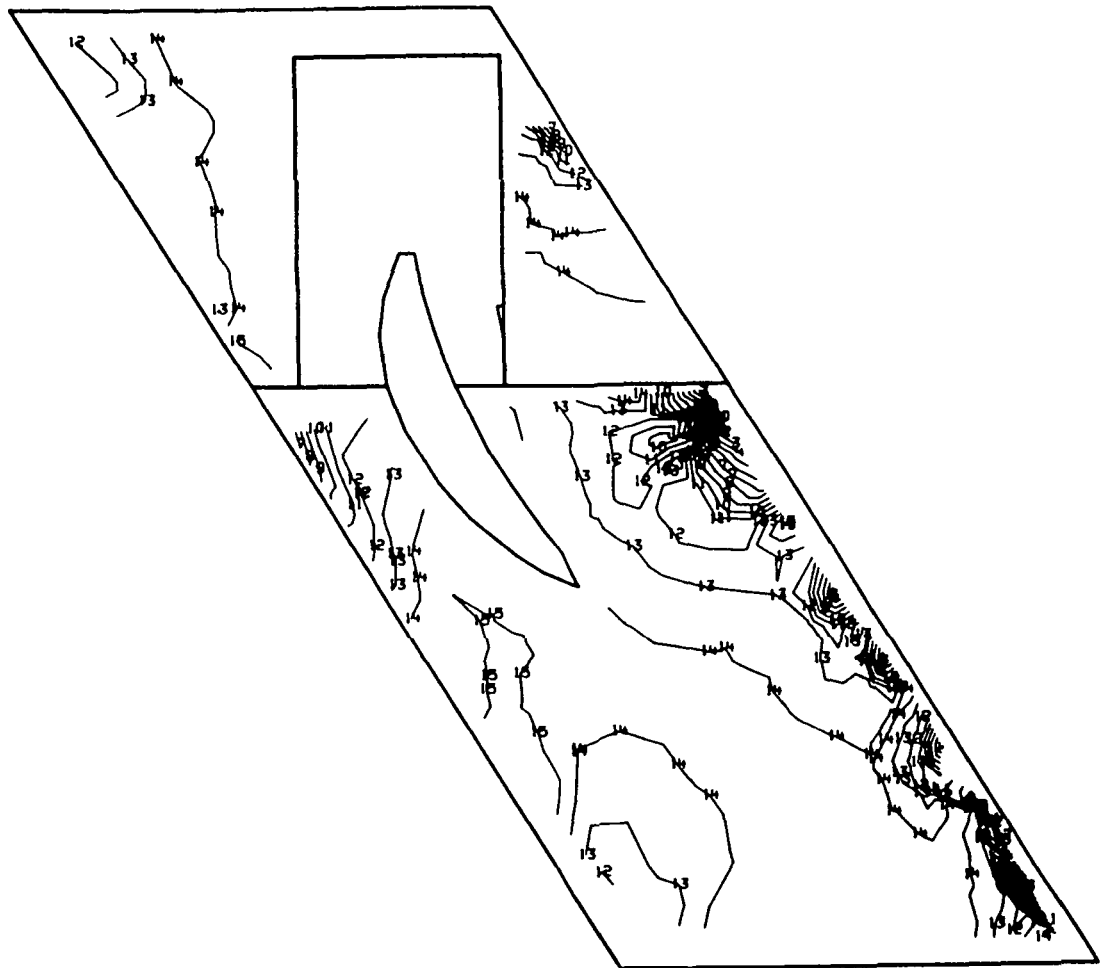

1	-1.628146E C5	11	-4.207217E C4
2	-1.507404E O5	12	-2.999795E C4
3	-1.386661E C5	13	-1.792372E O4
4	-1.265919E C5	14	-5.849492E C3
5	-1.145176E C5	15	6.224734E C3
6	-1.024434E C5	16	1.829896E C4
7	-9.036913E C4	17	3.027319E C4
8	-7.829488E C4	18	4.244741E C4
9	-6.622063E C4	19	5.452164E C4
10	-5.414640E C4	20	6.659569E C4

Fig. 3.3-6 Model F2, View 1, 115% Load, Minor Principal Stress (psi)

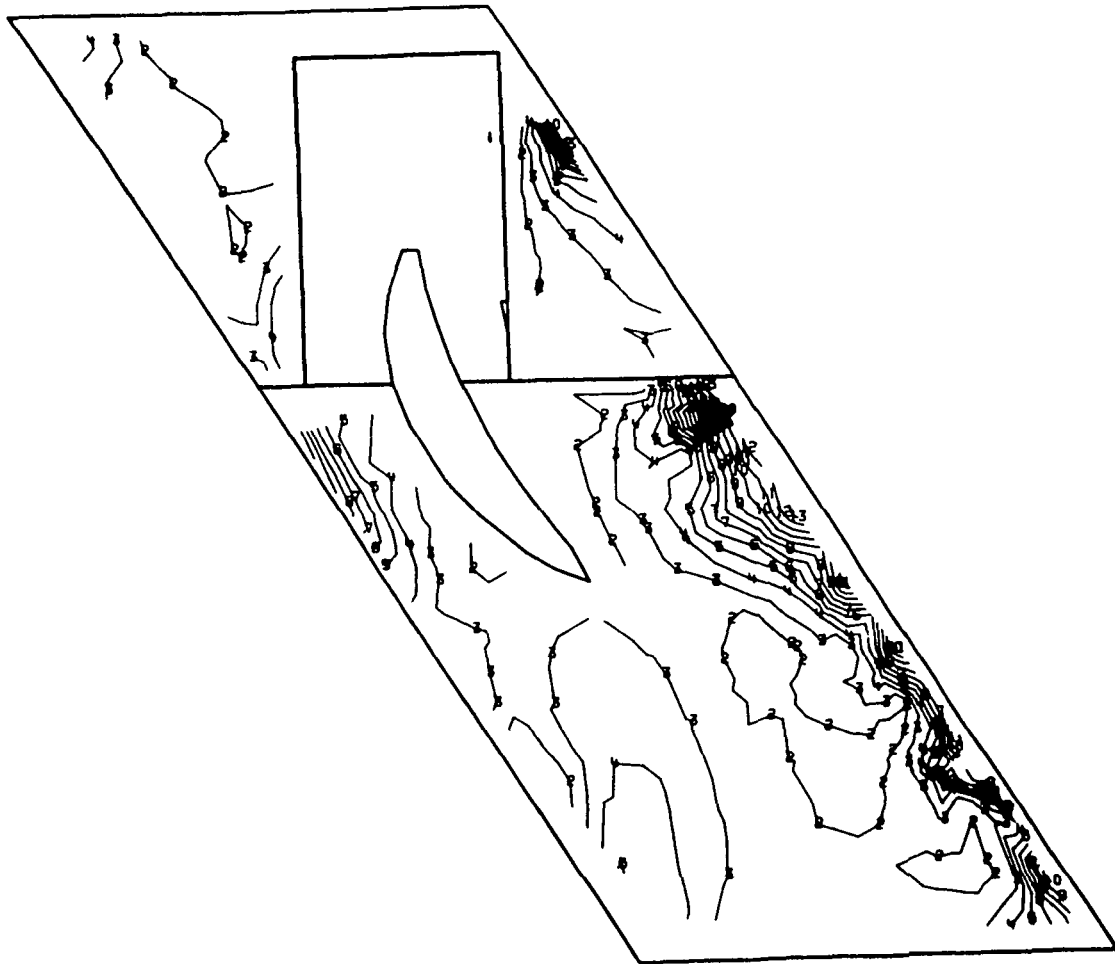

1	2.330343E C2	11	6.321221E C4
2	6.530949E C3	12	6.951013E O4
3	1.282887E C4	13	7.580800E O4
4	1.912679E C4	14	8.210588E C4
5	2.542470E O4	15	8.840375E C4
6	3.172262E C4	16	9.470163E O4
7	3.802054E C4	17	1.009995E C5
8	4.431846E C4	18	1.072974E C5
9	5.061628E O4	19	1.135953E C5
10	5.691429E C4	20	1.198936E O5

Fig. 3.3-7 Model F2, View 1, 115% Load, Maximum Shear Stress (psi)

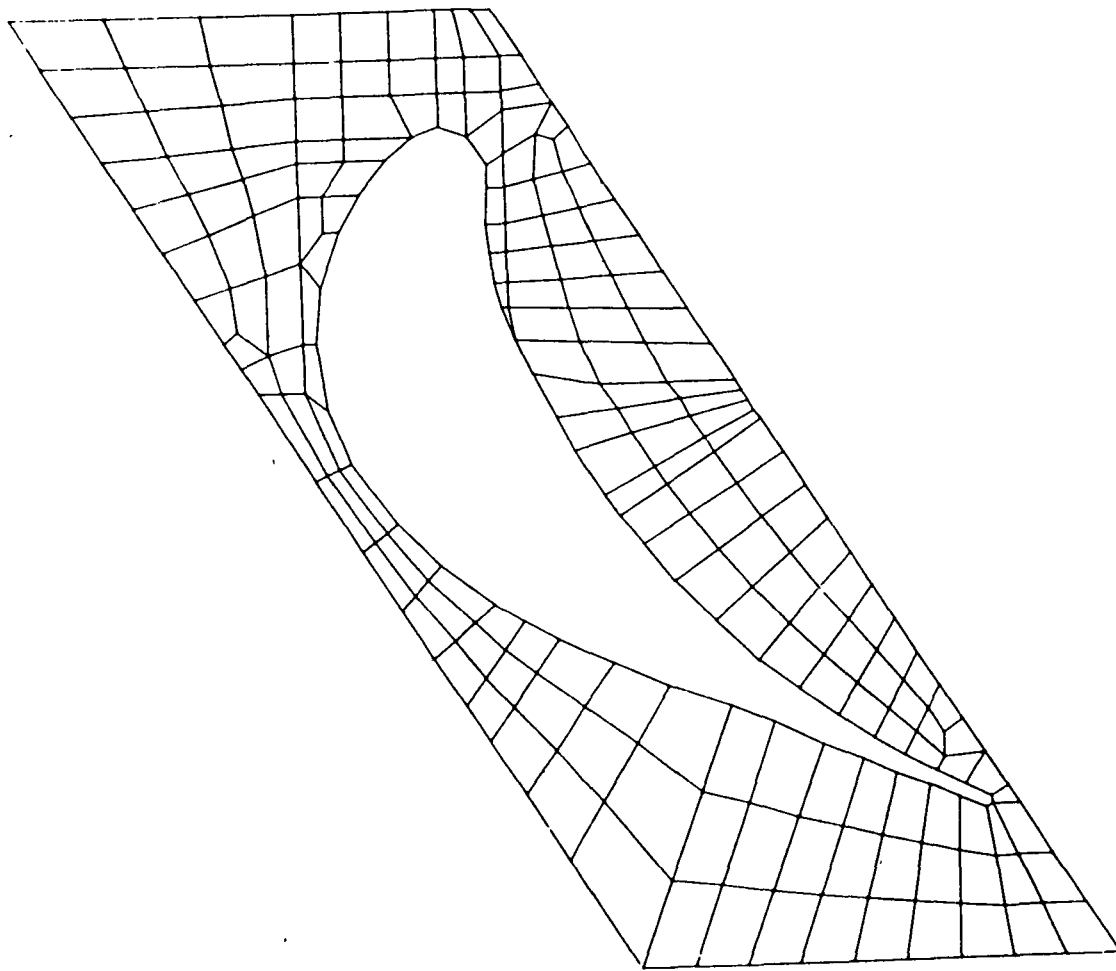

Fig. 3.3-8 - Model F2, View 2, Shroud Inside Surface



1	-2.199713E 04	11	1.088718E 05
2	-8.910215E 03	12	1.219587E 05
3	4.176695E 03	13	1.350456E 05
4	1.726361E 04	14	1.481324E 05
5	3.035052E 04	15	1.612193E 05
6	4.343743E 04	16	1.743062E 05
7	5.652434E 04	17	1.873931E 05
8	6.961119E 04	18	2.004799E 05
9	8.269806E 04	19	2.135668E 05
10	9.578494E 04	20	2.266542E 05

Fig. 3.3-9 Model F2, View 2, FPL Load Major Principal Stress (psi)

3.3-9

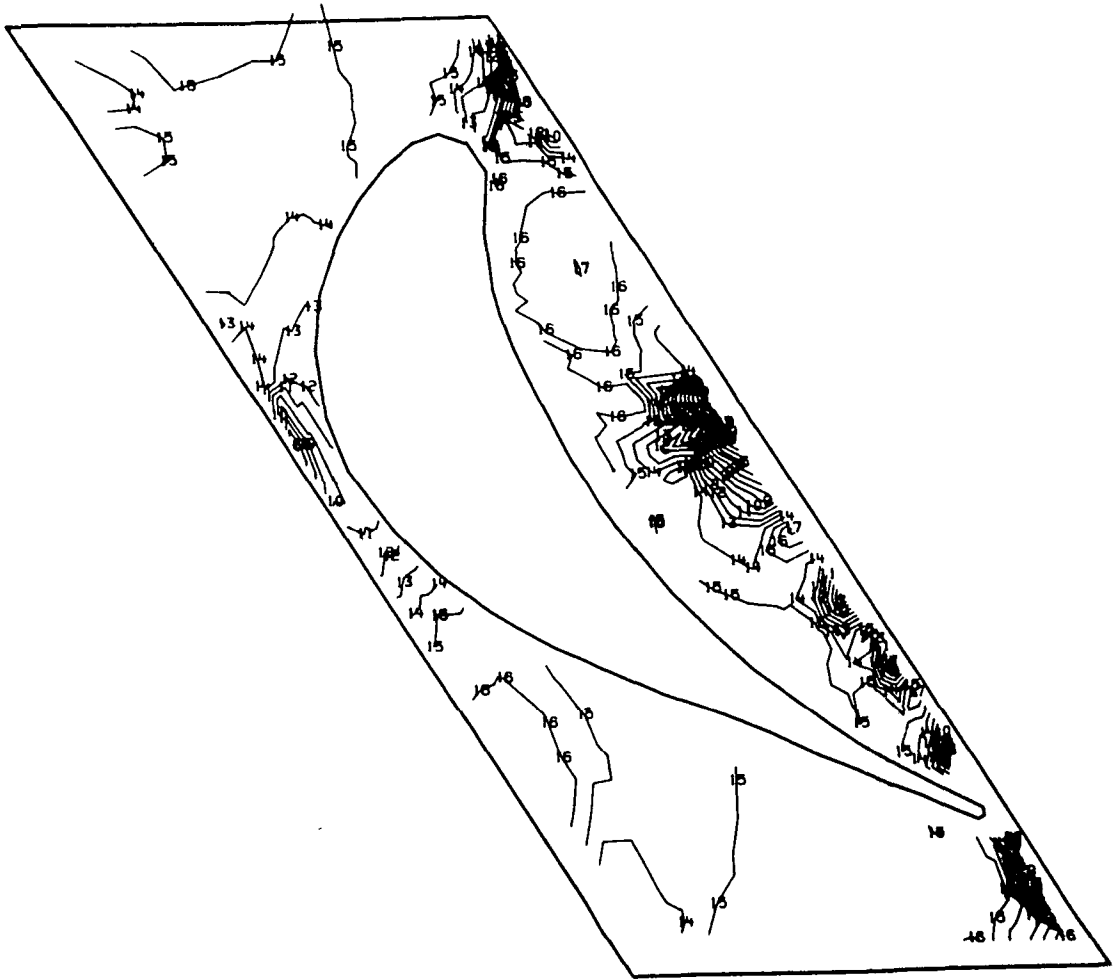

1	-1.786206E 05	11	-5.795189E 04
2	-1.665538E 05	12	-4.588502E 04
3	-1.544869E 05	13	-3.381816E 04
4	-1.424200E 05	14	-2.175130E 04
5	-1.303531E 05	15	-9.684434E 03
6	-1.182863E 05	16	2.382430E 03
7	-1.062194E 05	17	1.444929E 04
8	-9.415250E 04	18	2.651616E 04
9	-8.208563E 04	19	3.858302E 04
10	-7.001875E 04	20	5.064986E 04

Fig. 3.3-10 Model F2, View 2, FPL Load Major Principal Stress (psi)

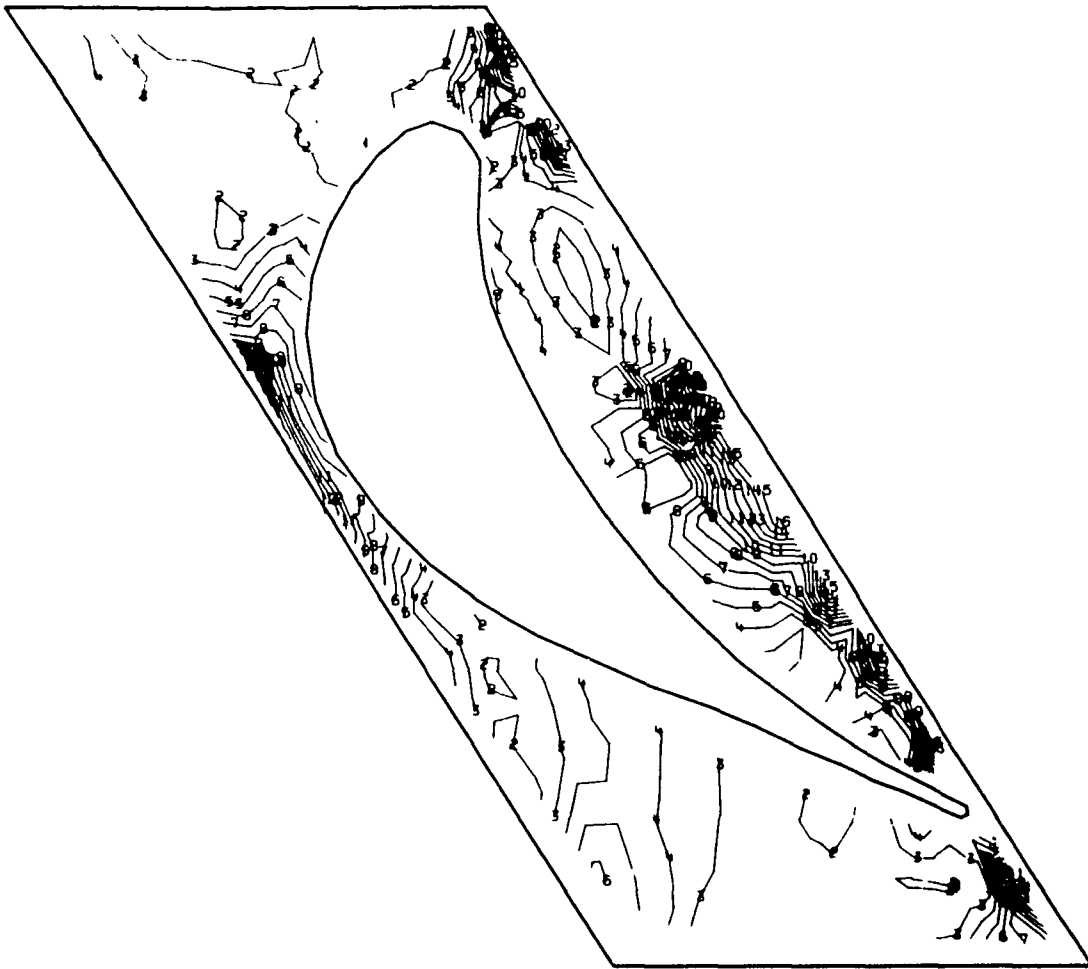

1	9.422349E 02	11	5.162555E 04
2	5.920566E 03	12	5.670389E 04
3	1.099890E 04	13	6.178222E 04
4	1.607723E 04	14	6.686050E 04
5	2.115556E 04	15	7.193881E 04
6	2.623389E 04	16	7.701713E 04
7	3.131223E 04	17	8.209544E 04
8	3.639056E 04	18	8.717375E 04
9	4.146889E 04	19	9.225206E 04
10	4.654722E 04	20	9.733063E 04

Fig. 3.3-11 Model F2, View 2, FPL Load, Shear Maximum Stress (psi)

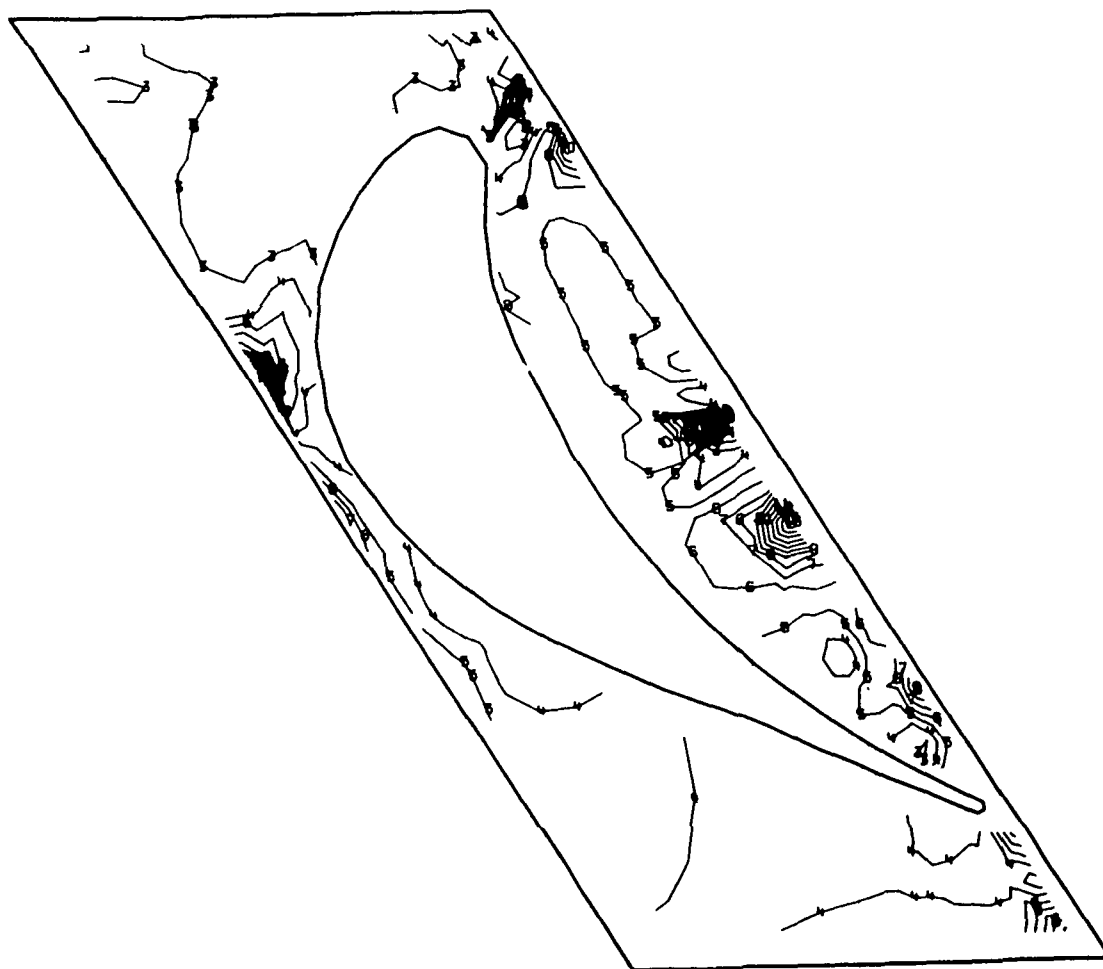

1	-2.187225E C4	11	1.048405E C5
2	-9.200961E C3	12	1.175118E C5
3	3.470328E C3	13	1.301830E C5
4	1.614162E C4	14	1.428543E C5
5	2.881291E C4	15	1.555255E C5
6	4.148420E C4	16	1.681968E C5
7	5.415548E C4	17	1.808680E C5
8	6.682675E C4	18	1.935393E C5
9	7.949800E C4	19	2.062105E C5
10	9.216925E C4	20	2.188823E C5

Fig. 3.3-12 Model F2, View 2, 115% Load, Major Principal Stress (psi)

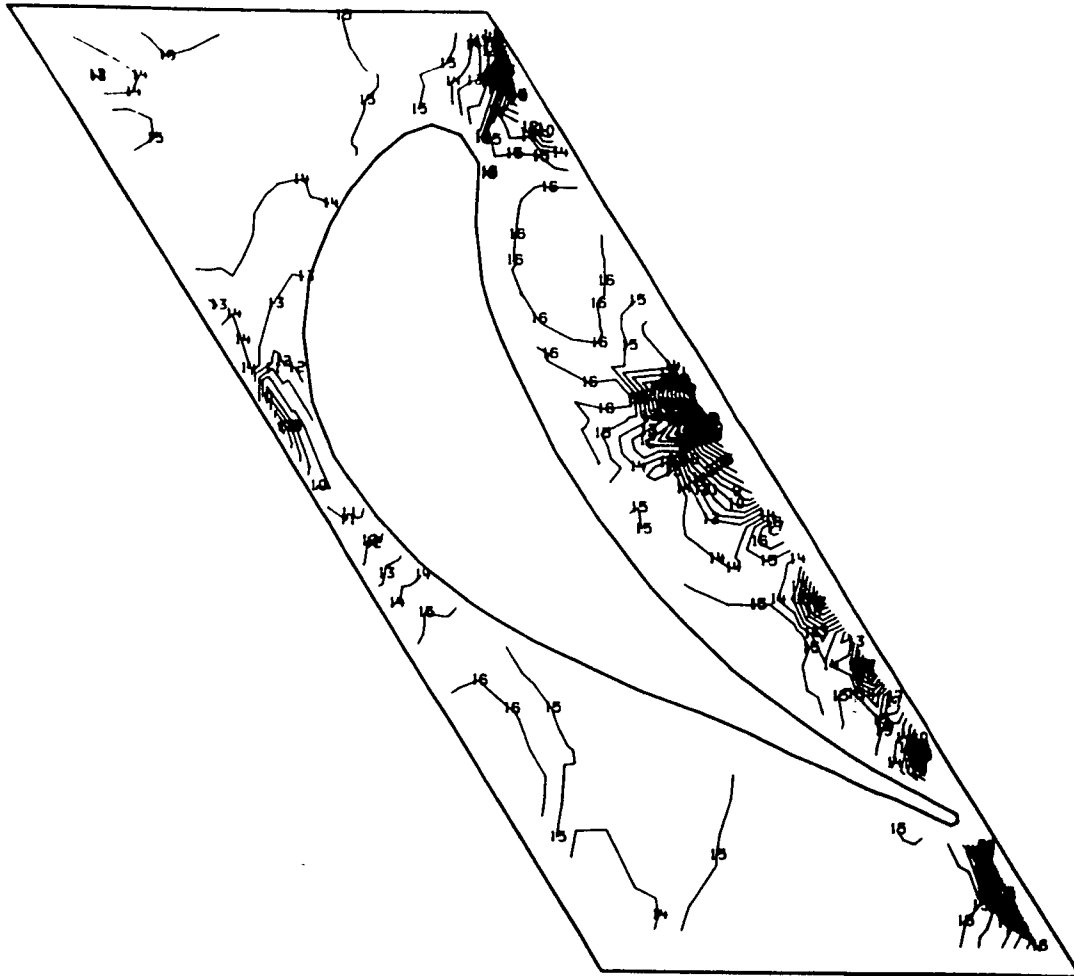

1	-1.732597E C5	11	-5.532C31E C4
2	-1.614658E C5	12	-4.352638E C4
3	-1.496718E 05	13	-3.173244E 04
4	-1.378779E C5	14	-1.993850E C4
5	-1.260839E C5	15	-8.144563E 03
6	-1.14290E C5	16	3.649375E 03
7	-1.024961E C5	17	1.544331E C4
8	-9.070213E C4	18	2.723725E C4
9	-7.89C819E C4	19	3.9C3119E C4
10	-6.711425E C4	20	5.082521E C4

Fig. 3.3-13 Model F2, View 2, 115% Load, Minor Principal Stress (psi)

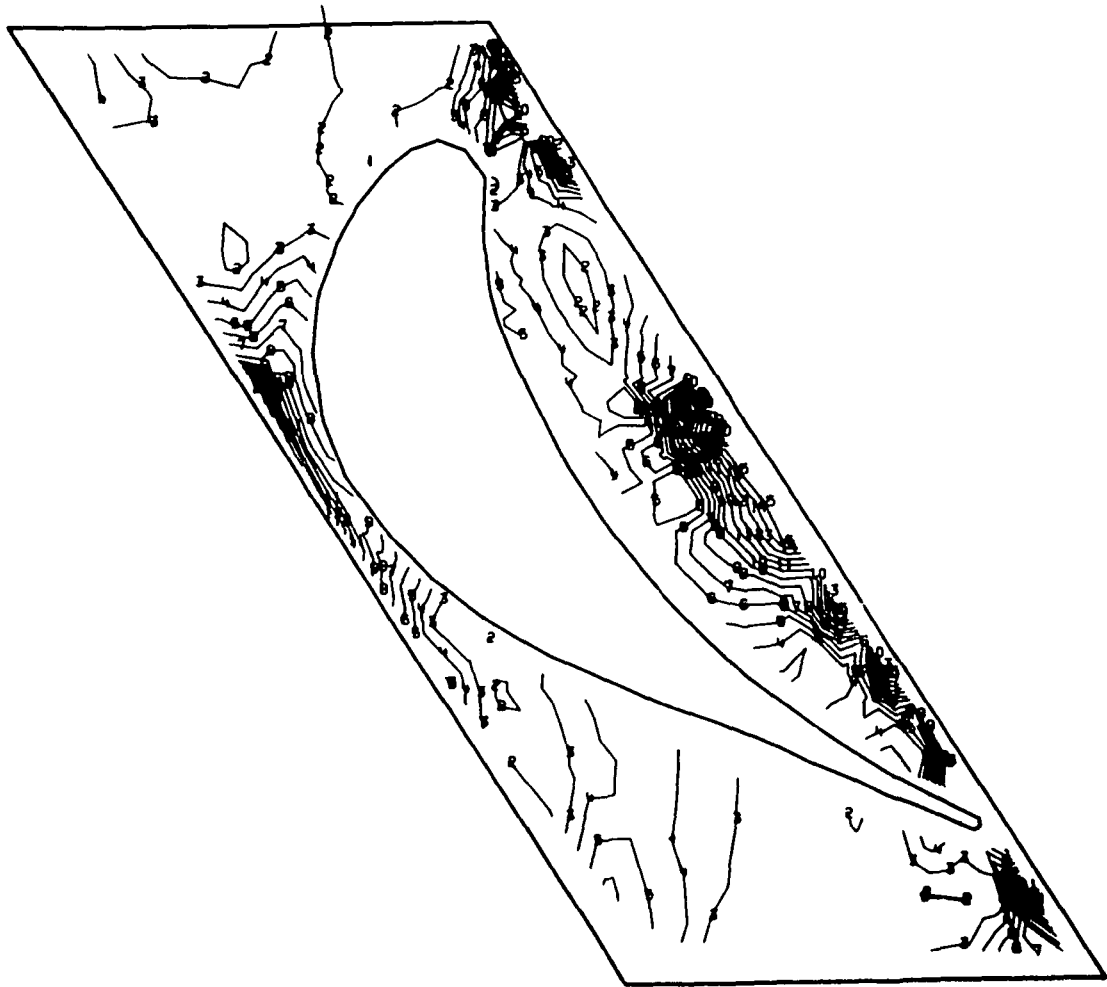

1	9.424875E C2	11	4.992131E C4
2	5.841367E C3	12	5.482020E C4
3	1.074025E C4	13	5.972908E C4
4	1.563913E C4	14	6.462796E C4
5	2.053802E C4	15	6.952681E C4
6	2.542690E C4	16	7.442569E C4
7	3.033578E C4	17	7.932456E C4
8	3.523466E C4	18	8.422344E C4
9	4.013355E C4	19	8.912231E C4
10	4.503243E C4	20	9.402131E C4

Fig. 3.3-14 Model F2, View 2, 115% Load, Maximum Shear Stress (psi)

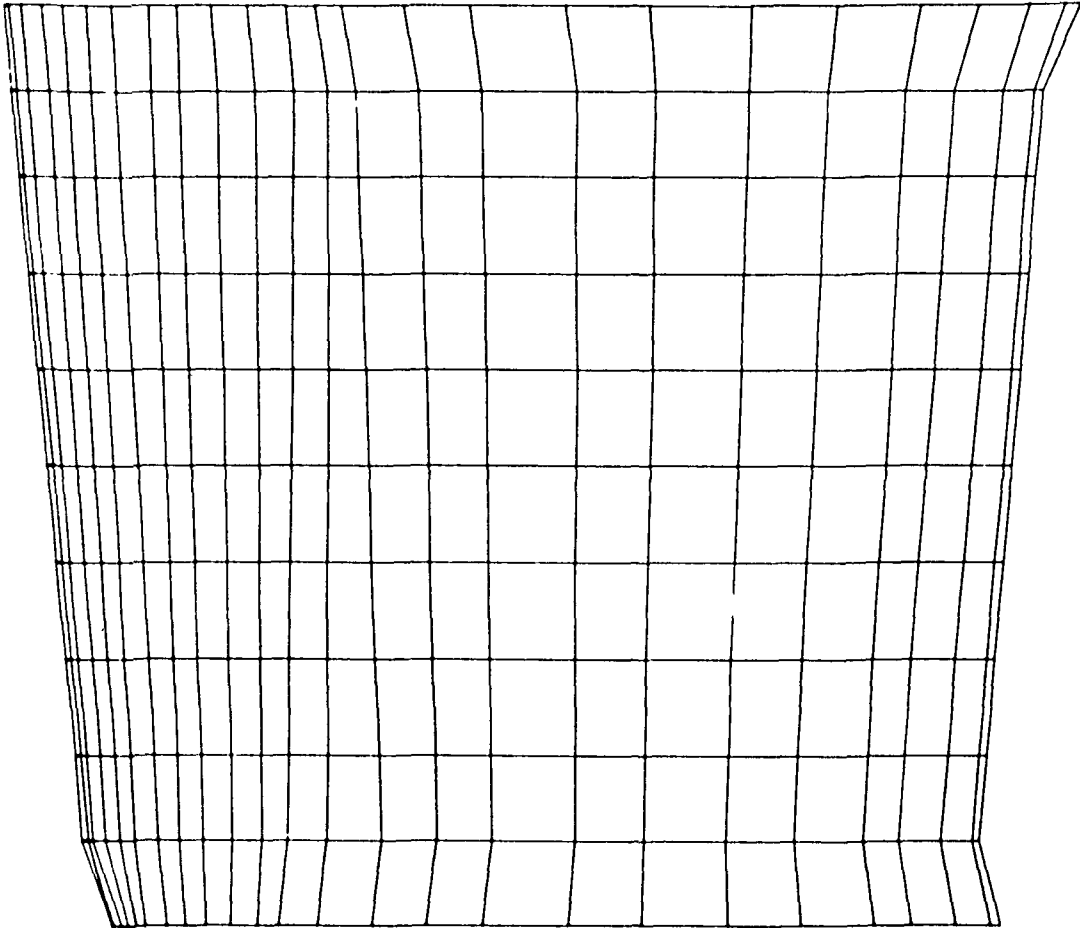
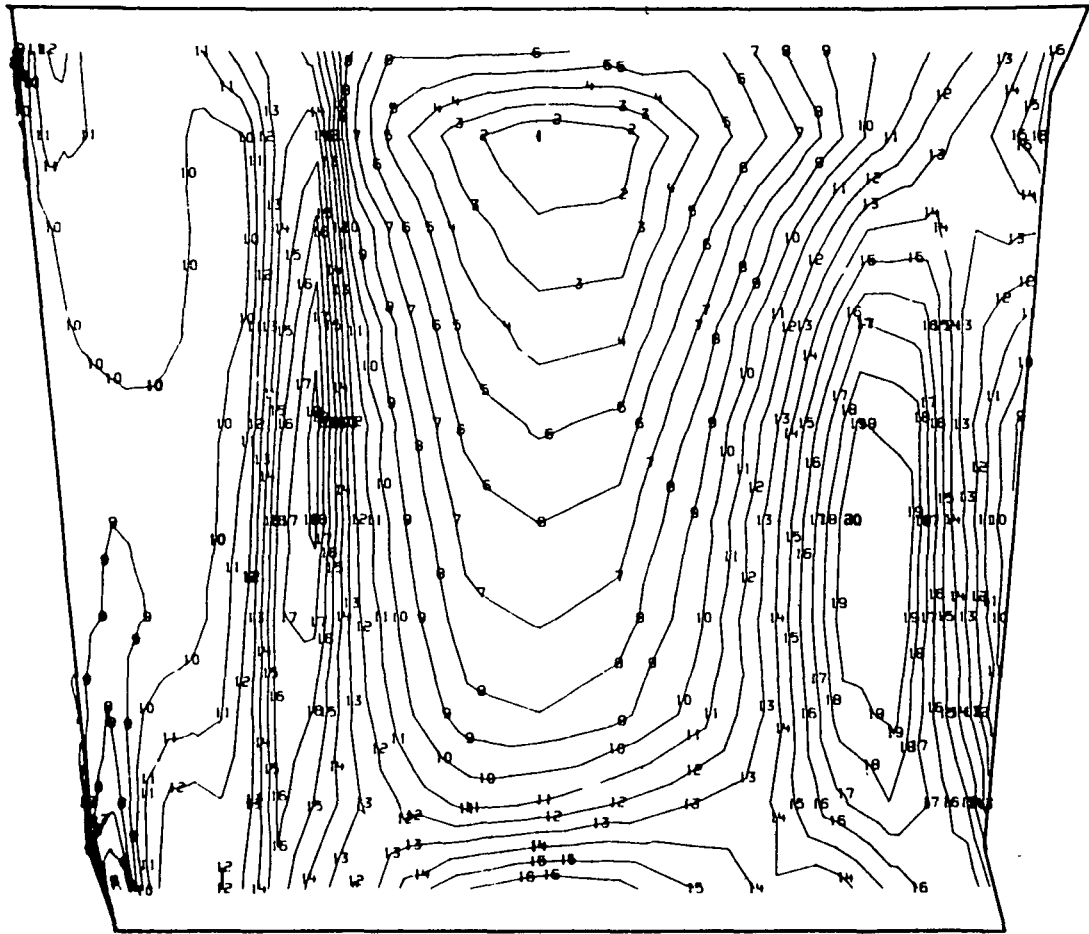

Fig. 3.3-15 Model F2, View 3, Airfoil Pressure Side

3.3-15



1	-2.376680E 04	11	2.241012E 03
2	-2.116602E 04	12	4.841793E 03
3	-1.856524E 04	13	7.442574E 03
4	-1.596446E 04	14	1.004336E 04
5	-1.336368E 04	15	1.264414E 04
6	-1.076289E 04	16	1.524492E 04
7	-8.162113E 03	17	1.784570E 04
8	-5.561332E 03	18	2.044648E 04
9	-2.960551E 03	19	2.304726E 04
10	-3.597695E 02	20	2.564804E 04

Fig. 3.3-16 Model F2, View 3, FPL Load Major Principal Stress (psi)

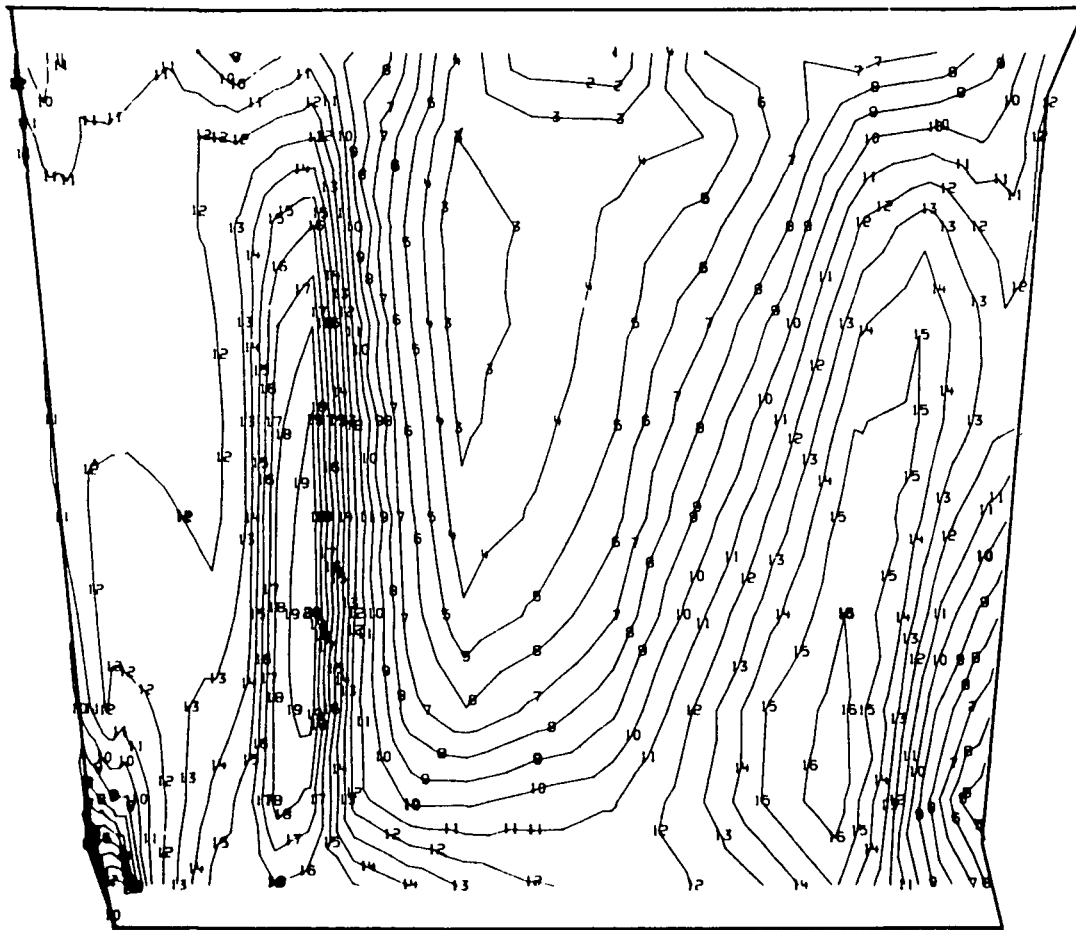

1	-3.463613E 04	11	-9.003746E 03
2	-3.207289E 04	12	-6.440509E 03
3	-2.950965E 04	13	-3.877273E 03
4	-2.694641E 04	14	-1.314039E 03
5	-2.438318E 04	15	1.249196E 03
6	-2.181994E 04	16	3.812431E 03
7	-1.925670E 04	17	6.375664E 03
8	-1.669346E 04	18	8.938898E 03
9	-1.413022E 04	19	1.150213E 04
10	-1.156658E 04	20	1.406533E 04

Fig. 3.3-17 Model F2, View 3, FPL Load, Minor Principal Stress (psi)

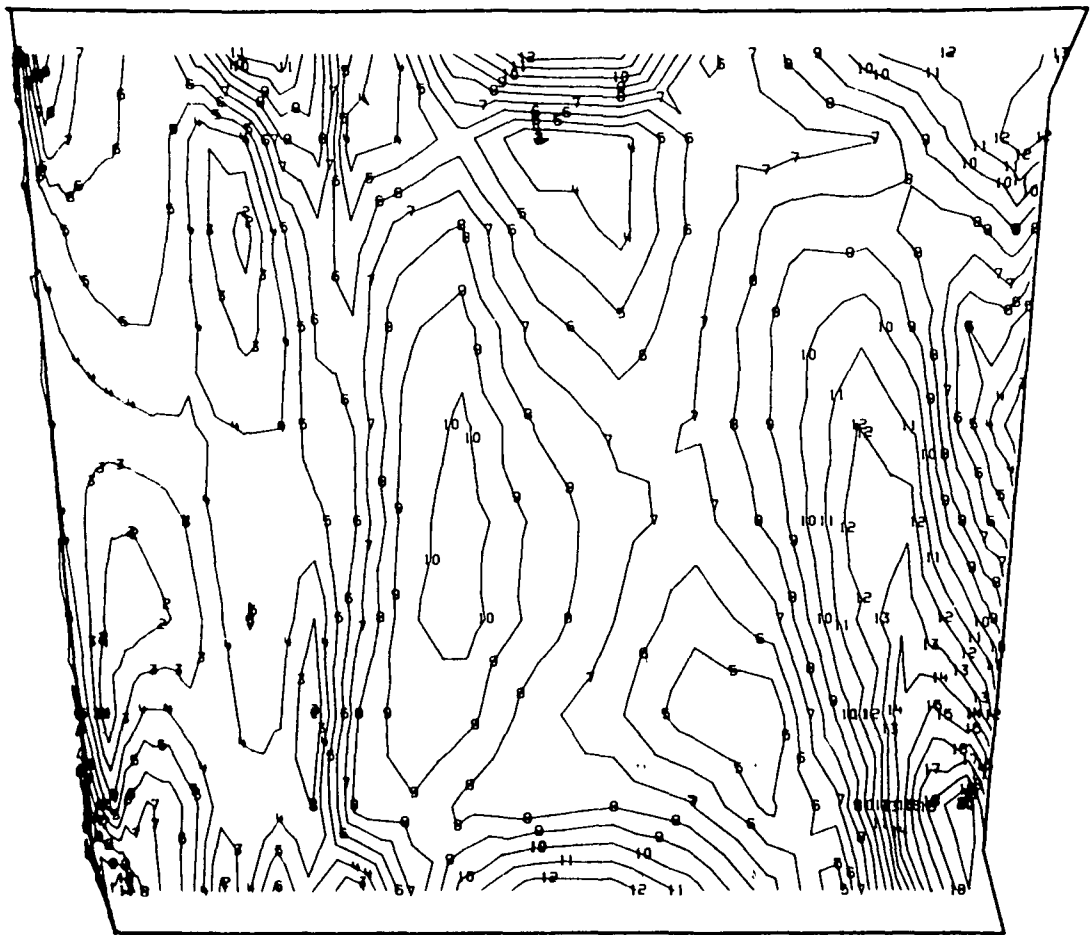

1	2.938469E 02	11	1.011201E 04
2	1.275664F 03	12	1.109383E 04
3	2.257481E 03	13	1.207564E 04
4	3.239298E 03	14	1.305746E 04
5	4.221113E 03	15	1.403928E 04
6	5.202930E 03	16	1.502109E 04
7	6.184746E 03	17	1.600291E 04
8	7.166563E 03	18	1.698473E 04
9	8.148379E 03	19	1.796654E 04
10	9.130195E 03	20	1.894837E 04

Fig. 3.3-18 Model F2, View 3, FPL Load, Shear Maximum Stress (psi)

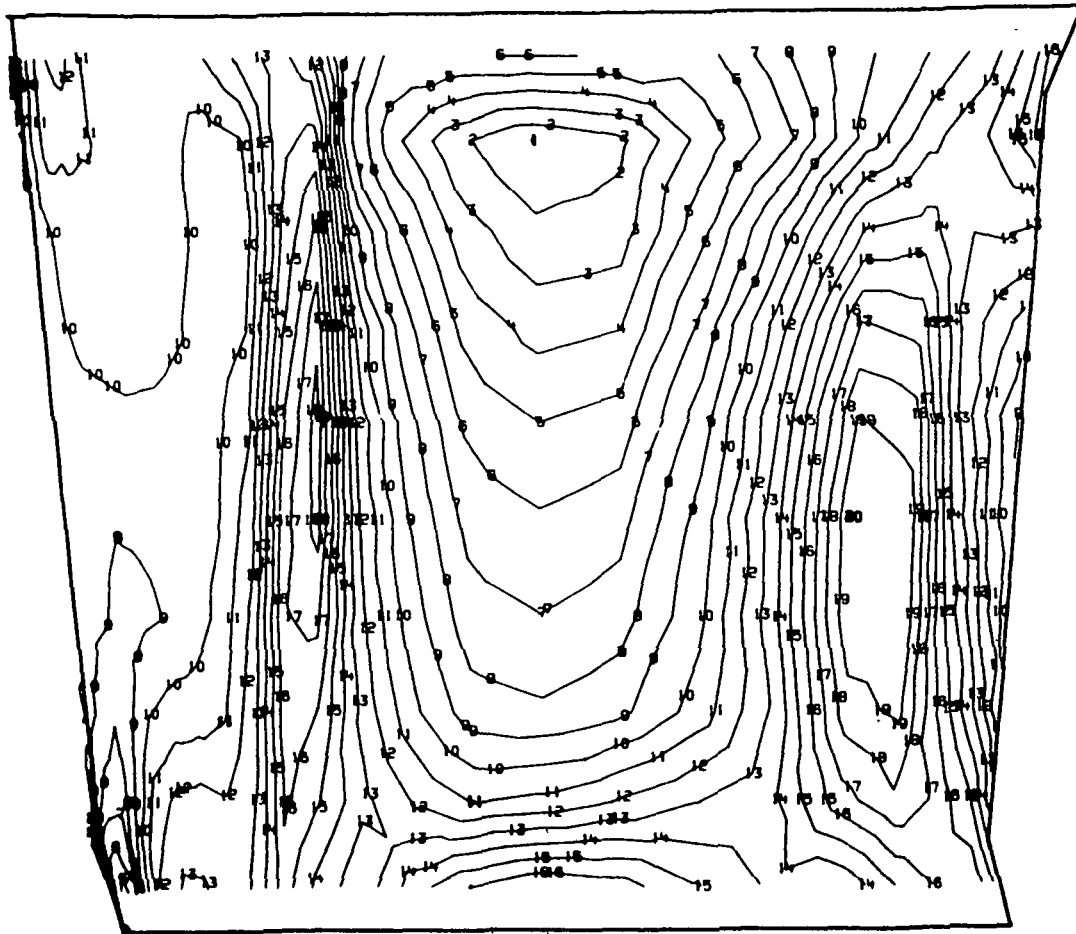

1	-2.562638E 04	11	2.351699E C3
2	-2.282857E C4	12	5.149504E C3
3	-2.003076E C4	13	7.947309E 03
4	-1.723295E C4	14	1.074511E C4
5	-1.443514E C4	15	1.354292E C4
6	-1.163734E 04	16	1.634072E C4
7	-8.839527E C3	17	1.913853E C4
8	-6.041719E C3	18	2.193633E 04
9	-3.243913E C3	19	2.472414E 04
10	-4.461069E 02	20	2.753194E C4

Fig. 3.3-19 Model F2, View 3, 115% Load, Major Principal Stress (psi)

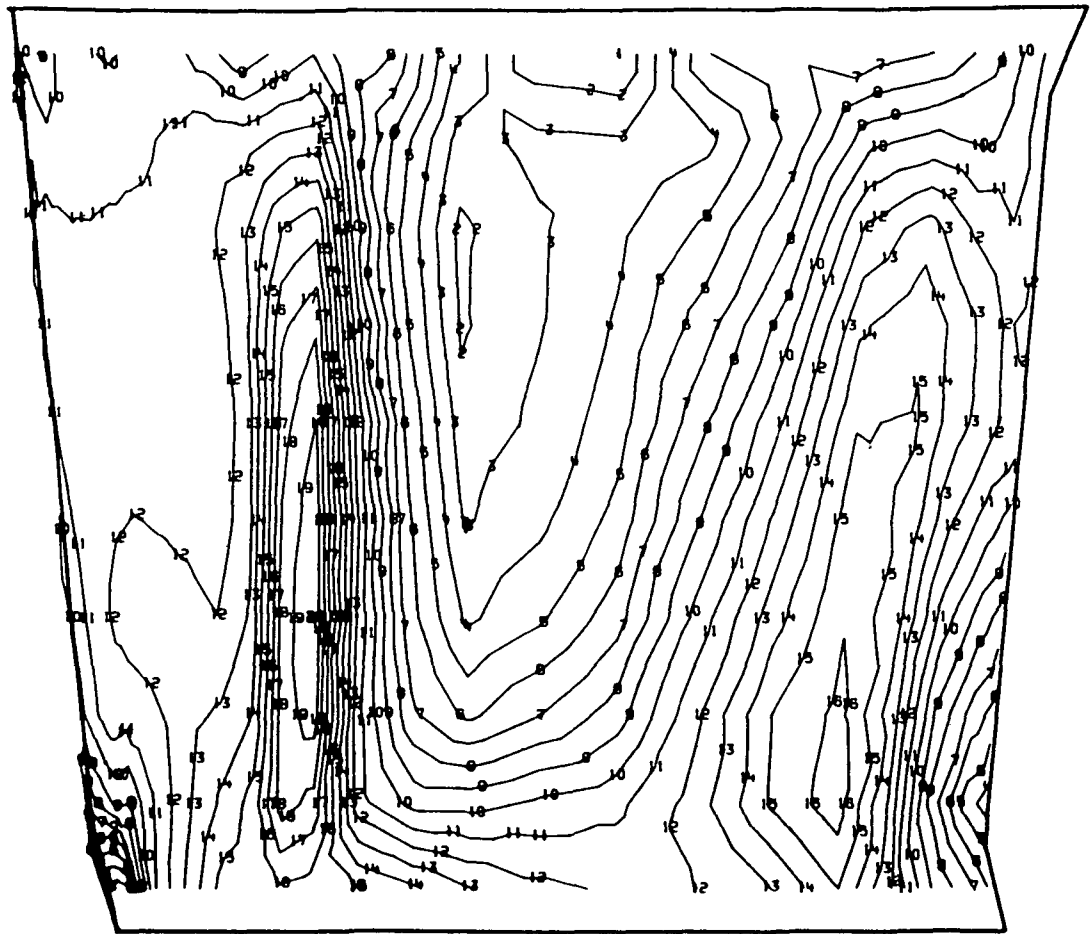

1	-3.586062E C4	11	-9.025895E C3
2	-3.317715E C4	12	-6.342422E C3
3	-3.049368E C4	13	-3.658951E C3
4	-2.781020E C4	14	-9.754795E C2
5	-2.512673E C4	15	1.707992E C3
6	-2.244326E C4	16	4.391461E C3
7	-1.975979E C4	17	7.074930E C3
8	-1.707631E C4	18	9.758398E C3
9	-1.439284E C4	19	1.244197E C4
10	-1.170927E C4	20	1.512533E C4

Fig. 3.3-20 Model F2, View 3, 115% Load, Minor Principal Stress (psi)

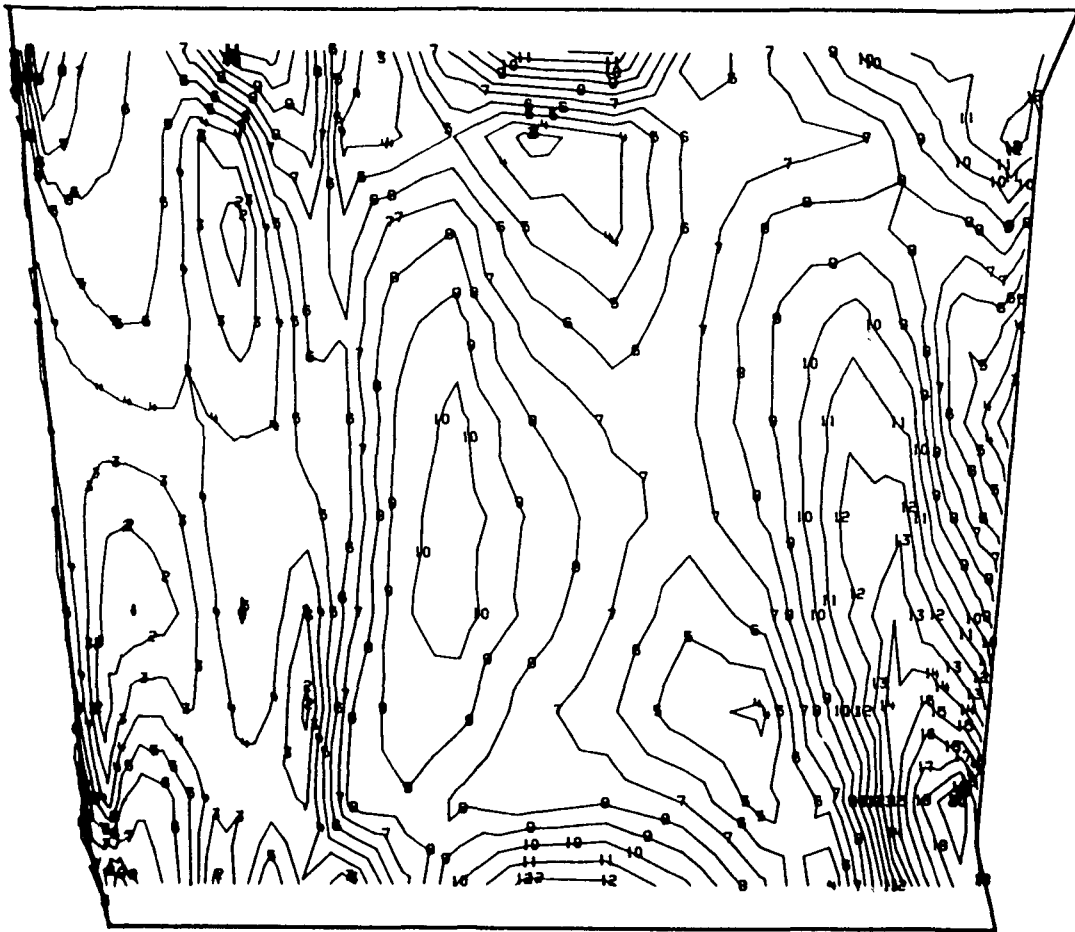

1	5.113767E 02	11	1.082673E C4
2	1.542913E C3	12	1.186927E C4
3	2.576449E 03	13	1.290180E C4
4	3.608986E C3	14	1.393434E C4
5	4.641520E C3	15	1.496687E C4
6	5.674055E C3	16	1.599941E 04
7	6.706590E 03	17	1.702194E C4
8	7.739125E 03	18	1.806448E C4
9	8.771660E 03	19	1.909701E C4
10	9.804195E C3	20	2.012957E C4

Fig. 3.3-21 Model F2, View 3, 115% Load, Maximum Shear Stress (psi)

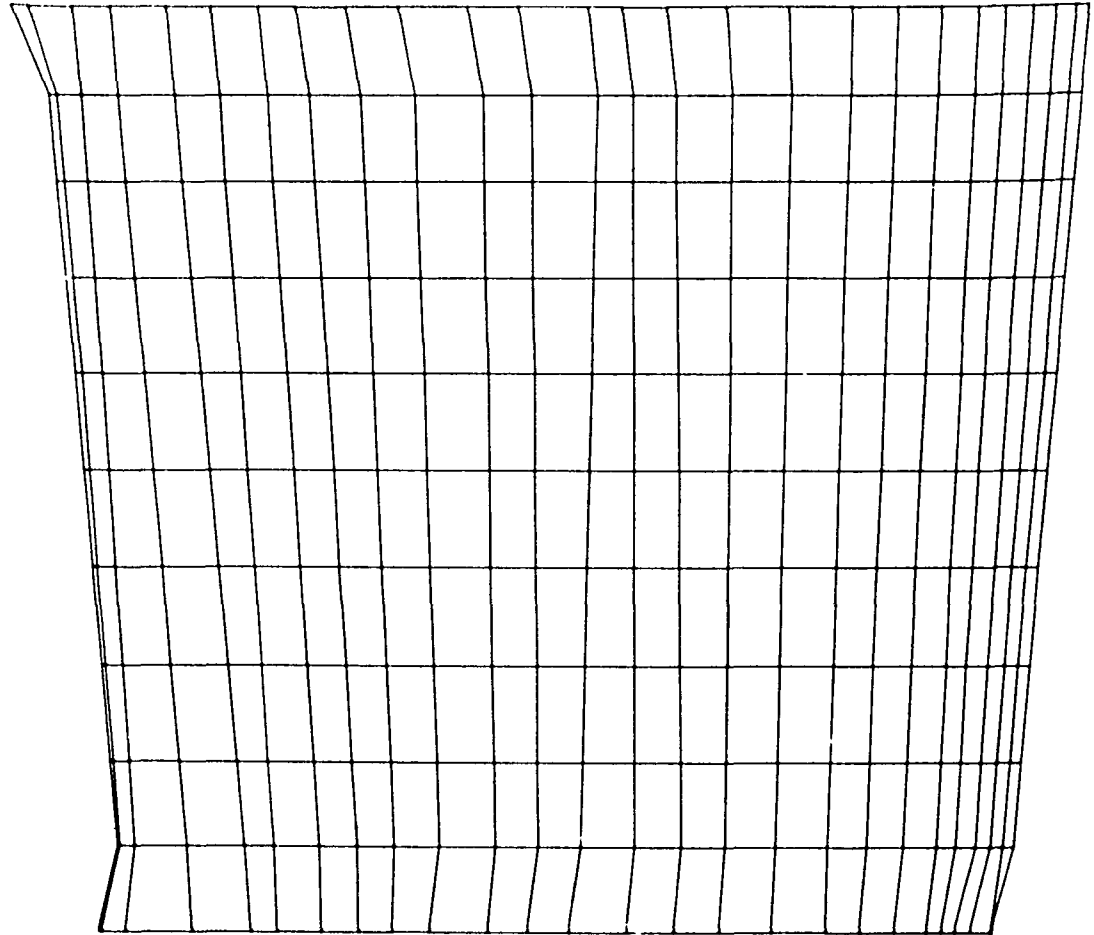
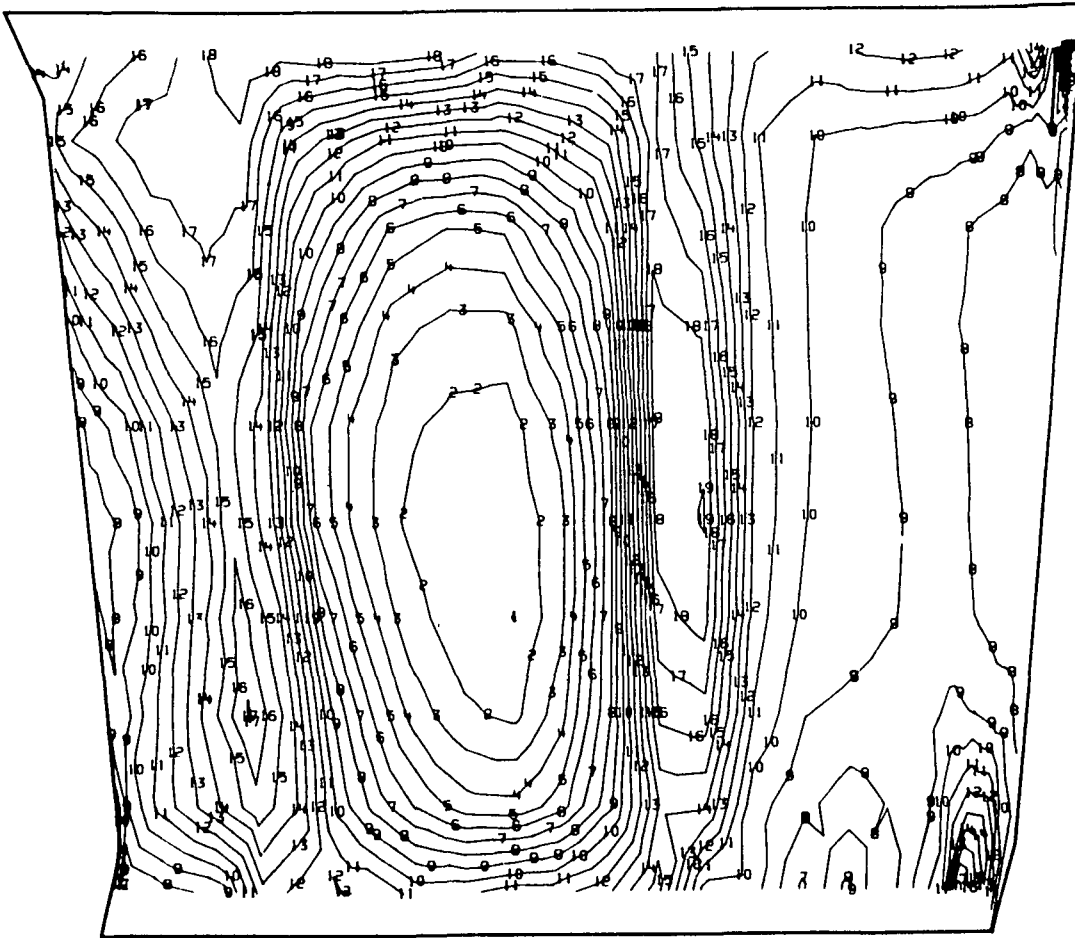
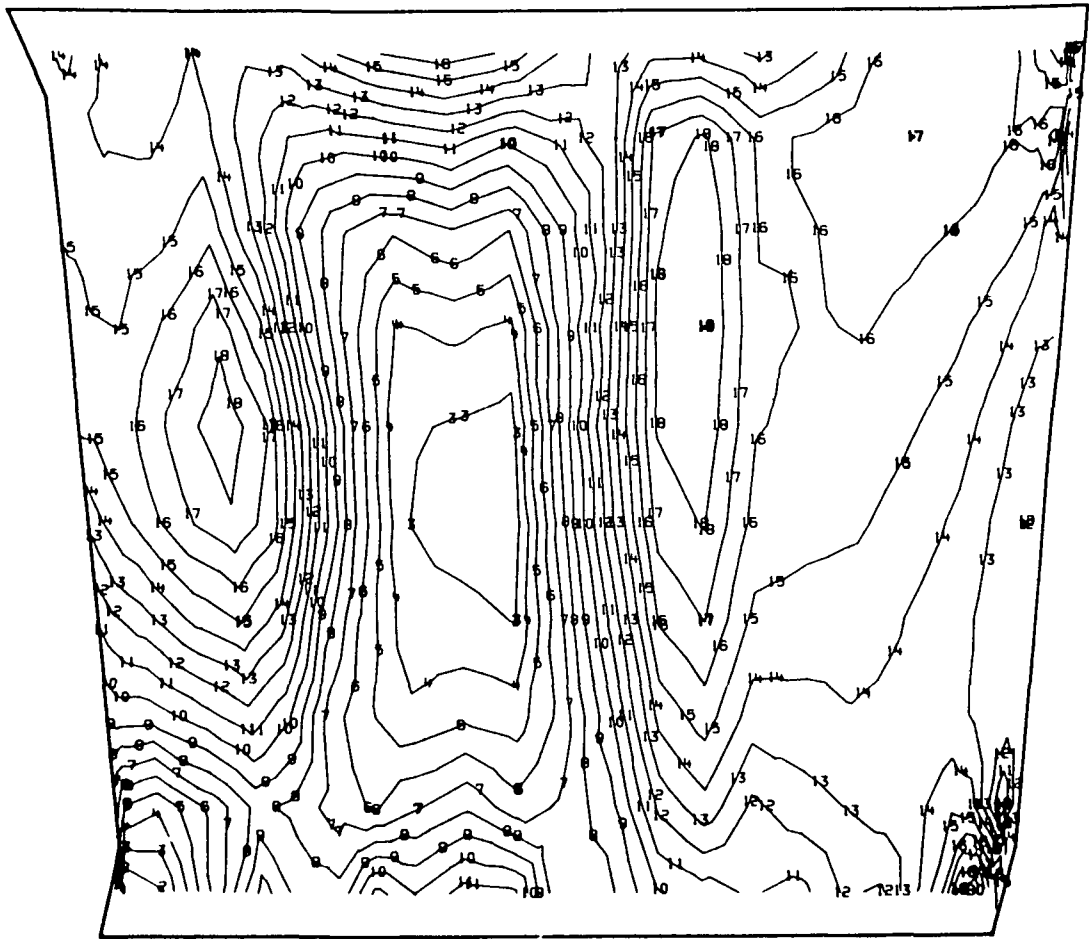

Fig. 3.3-22 Model F2, View 4, Airfoil Suction Side



1	-2.176562E 04	11	7.815926E 03
2	-1.880746E 04	12	1.077408E 04
3	-1.584931E 04	13	1.373223E 04
4	-1.289115E 04	14	1.669038E 04
5	-9.932996E 03	15	1.964854E 04
6	-6.974840E 03	16	2.260669E 04
7	-4.016687E 03	17	2.556484E 04
8	-1.058533E 03	18	2.852299E 04
9	1.899620E 03	19	3.148114E 04
10	4.857773E 03	20	3.443929E 04

Fig. 3.3-23 Model F-2, View 4, FPL Load Major Principal Stress (psi)



1	-3.981215E 04	11	-1.513789E 04
2	-3.734473E 04	12	-1.267047E 04
3	-3.487730E 04	13	-1.020304E 04
4	-3.240988E 04	14	-7.735617E 03
5	-2.994245E 04	15	-5.268191E 03
6	-2.747502E 04	16	-2.800768E 03
7	-2.500760E 04	17	-3.333447E 02
8	-2.254017E 04	18	2.134079E 03
9	-2.007275E 04	19	4.601500E 03
10	-1.760532E 04	20	7.068895E 03

Fig. 3.3-24 Model F2, View 4, FPL Load, Minor Principal Stress (psi)

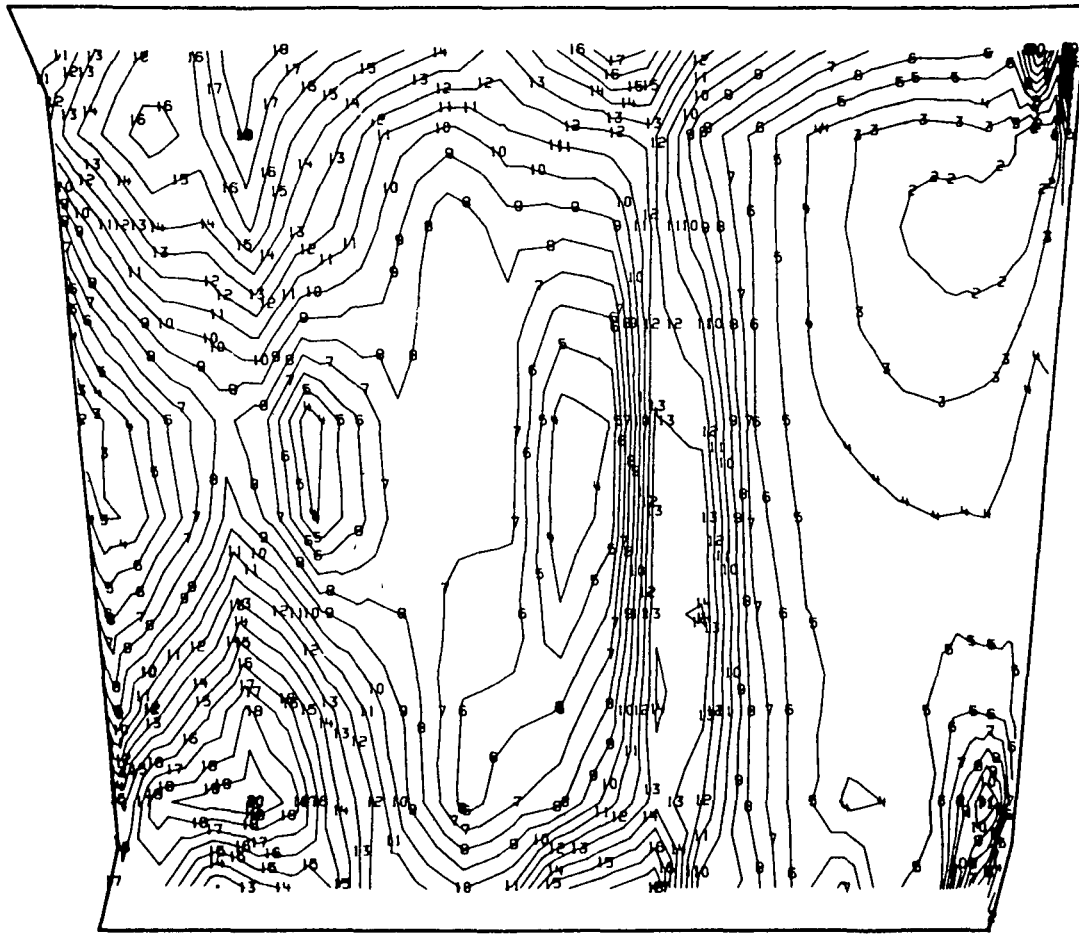

1	6.077434E	02	11	1.169322E	04
2	1.716793E	03	12	1.280727E	04
3	2.825844E	03	13	1.391632E	04
4	3.934894E	03	14	1.502536E	04
5	5.043941E	03	15	1.613441E	04
6	6.152988E	03	16	1.724346E	04
7	7.262035E	03	17	1.835250E	04
8	8.371082E	03	18	1.946155E	04
9	9.480129E	03	19	2.057060E	04
10	1.058918E	04	20	2.167970E	04

Fig. 3.3-25 Model F2, View 4, FPL Load, Shear Maximum Stress (psi)

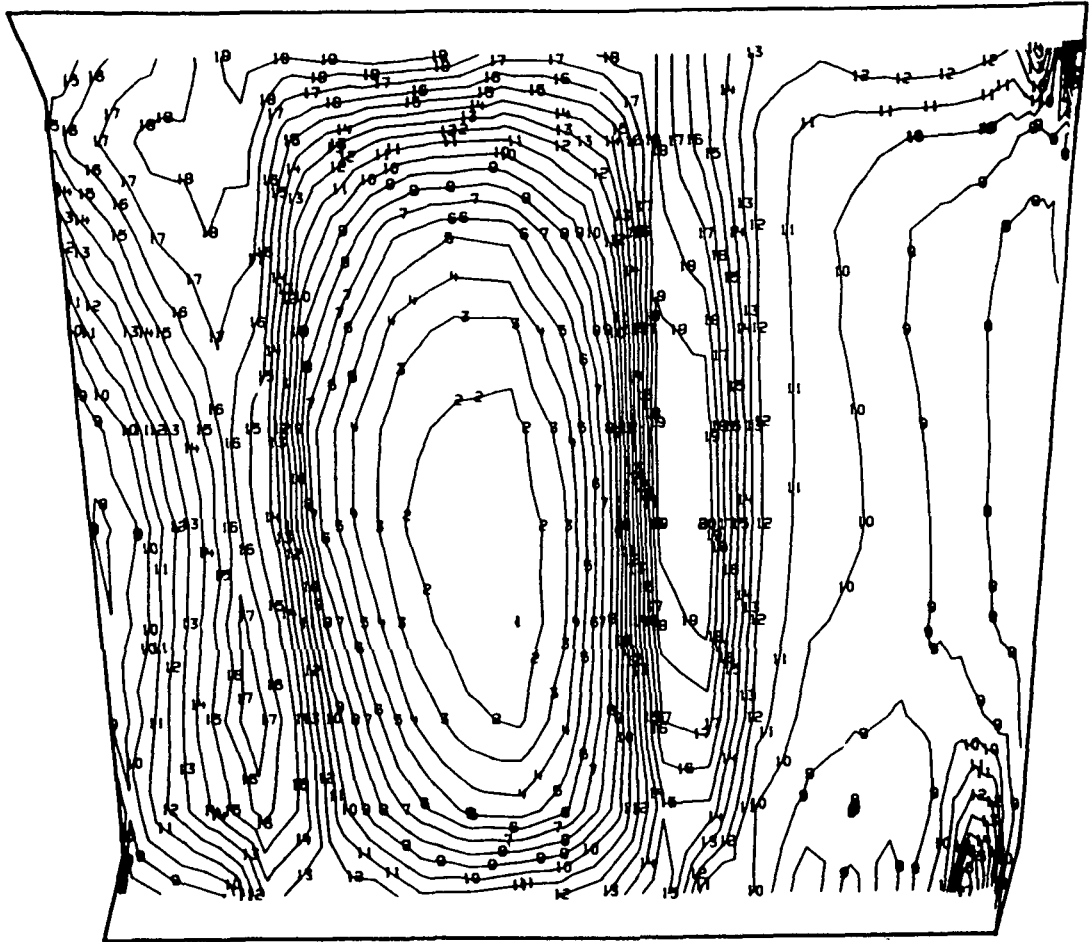

1	-2.305359E 04	11	7.118934E 03
2	-2.007270E 04	12	1.014022E 04
3	-1.705140E 04	13	1.316151E 04
4	-1.403011E 04	14	1.618280E 04
5	-1.100882E 04	15	1.920409E 04
6	-7.937523E 03	16	2.222538E 04
7	-4.566230E 03	17	2.524667E 04
8	-1.944939E 03	18	2.826796E 04
9	1.076353E 03	19	3.128925E 04
10	4.097645E 03	20	3.431056E 04

Fig. 3.3-26 Model F2, View 4, 115% Load, Major Principal Stress (psi)

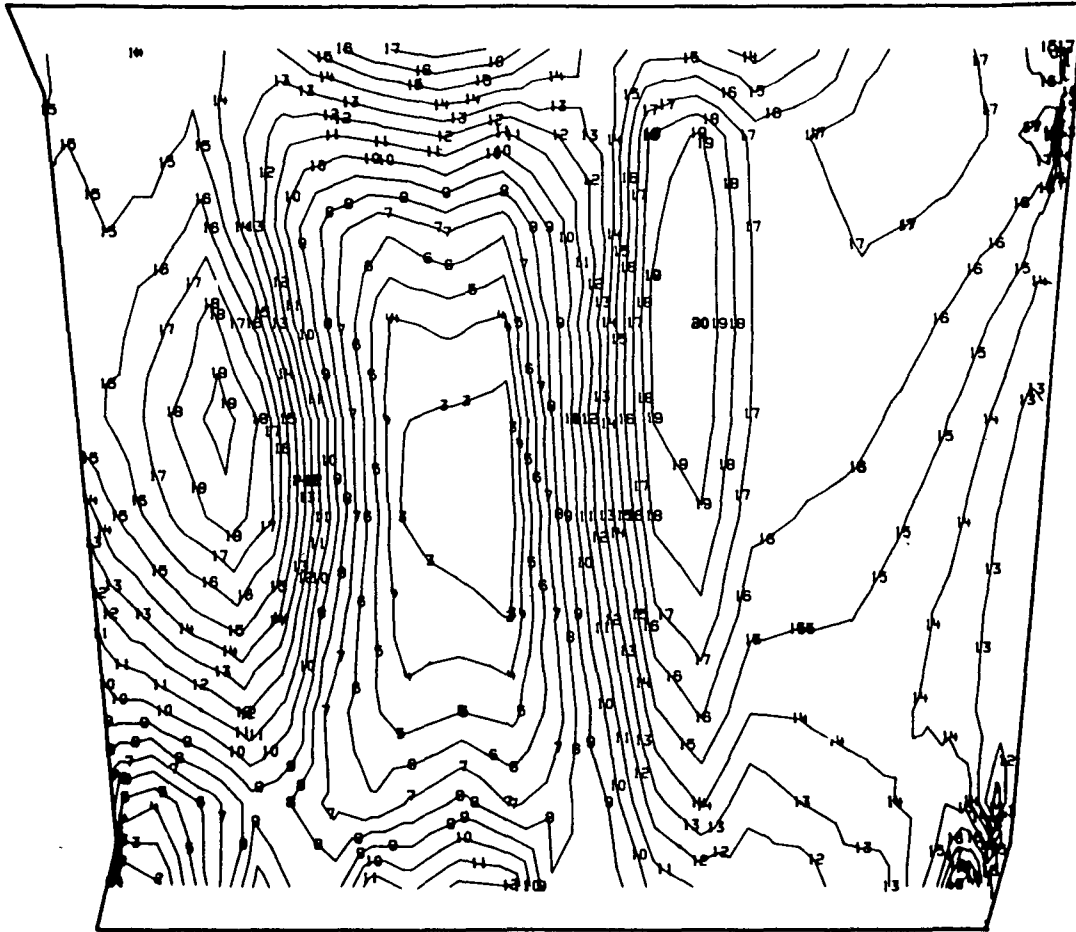

1	-4.2157C2E C4	11	-1.725819E 04
2	-3.966714E C4	12	-1.476831E C4
3	-3.717725E C4	13	-1.227843E C4
4	-3.468737F 04	14	-9.788543E C3
5	-3.219749E C4	15	-7.298660F 03
6	-2.970761E C4	16	-4.808777E C3
7	-2.721772E C4	17	-2.318897E C3
8	-2.472784E C4	18	1.709829E 02
9	-2.223796F C4	19	2.660863F C3
10	-1.974807E C4	20	5.150707E C3

Fig. 3.3-27 Model F2, View 4, 115% Load, Minor Principal Stress (psi)

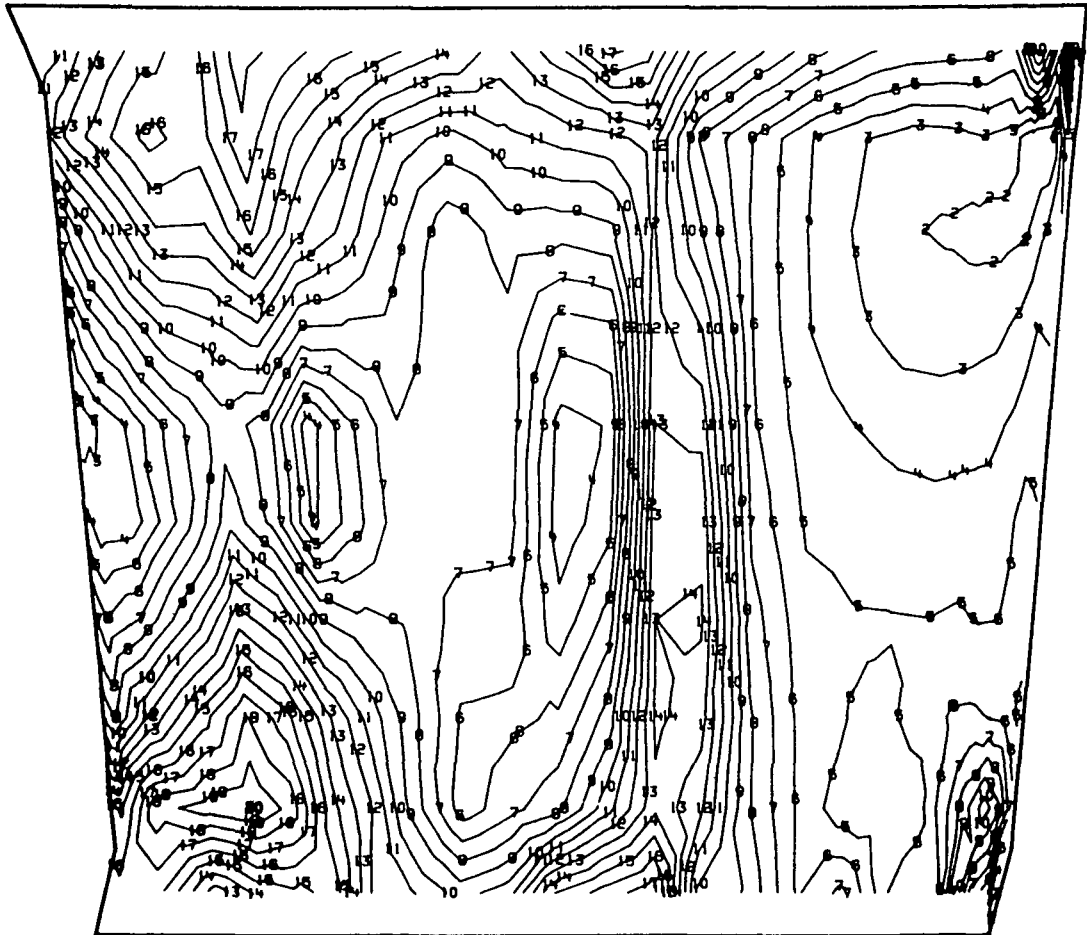

1	4.185837E 02	02	11	1.257855E C4
2	1.634581E C3		12	1.379454E 04
3	2.850577E C3		13	1.501054E C4
4	4.066574E C3		14	1.622654E C4
5	5.282570E C3		15	1.744253E C4
6	6.498566E C3		16	1.865853E C4
7	7.714563E C3		17	1.987452E C4
8	8.930559E C3		18	2.109052E C4
9	1.014655E C4		19	2.230652E C4
10	1.136255E 04		20	2.352253E C4

Fig. 3.3-28 Model F2, View 4, 115% Load, Maximum Shear Stress (psi)

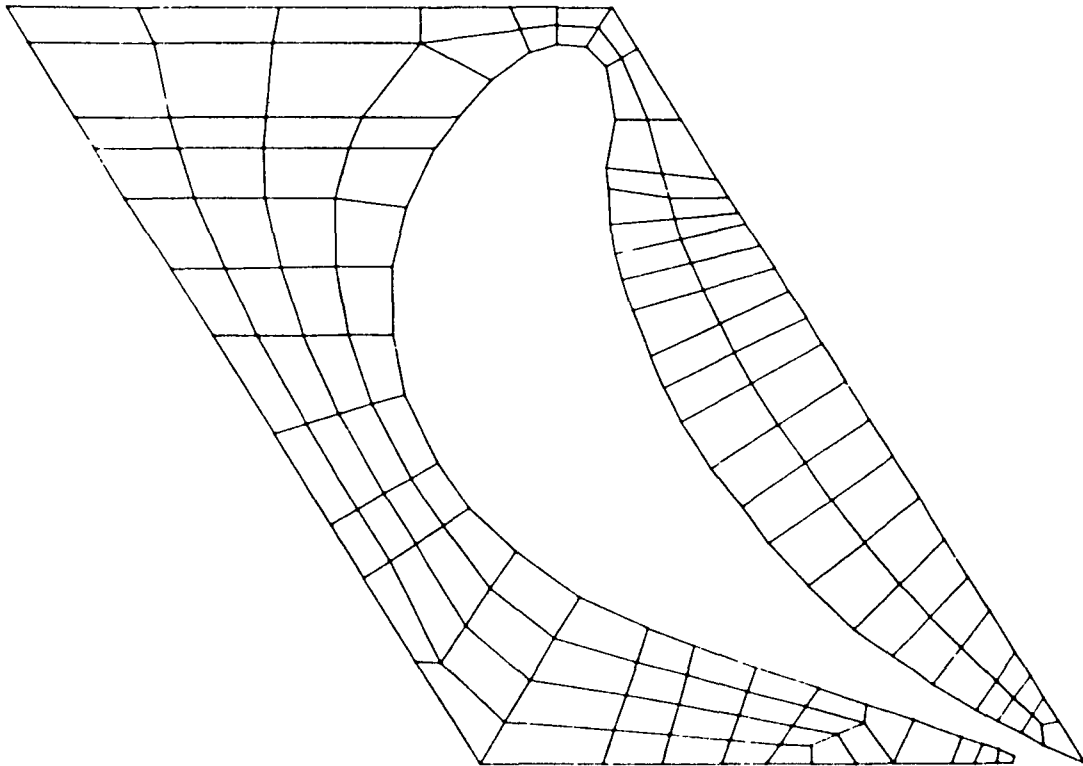
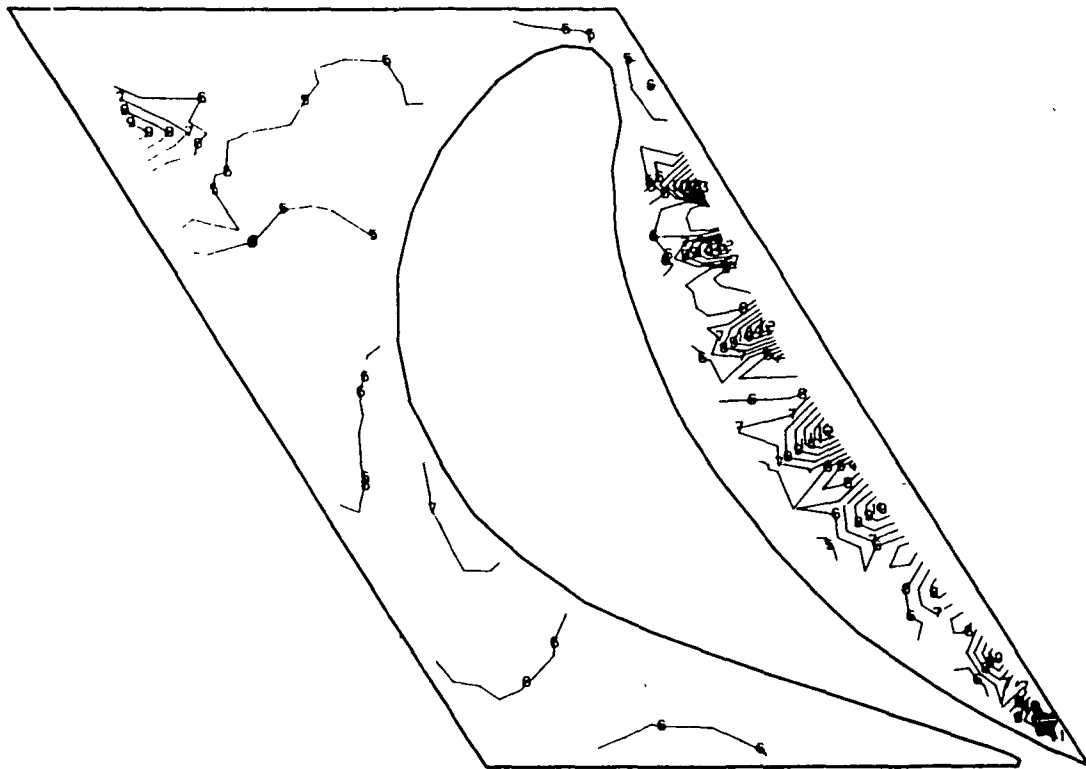
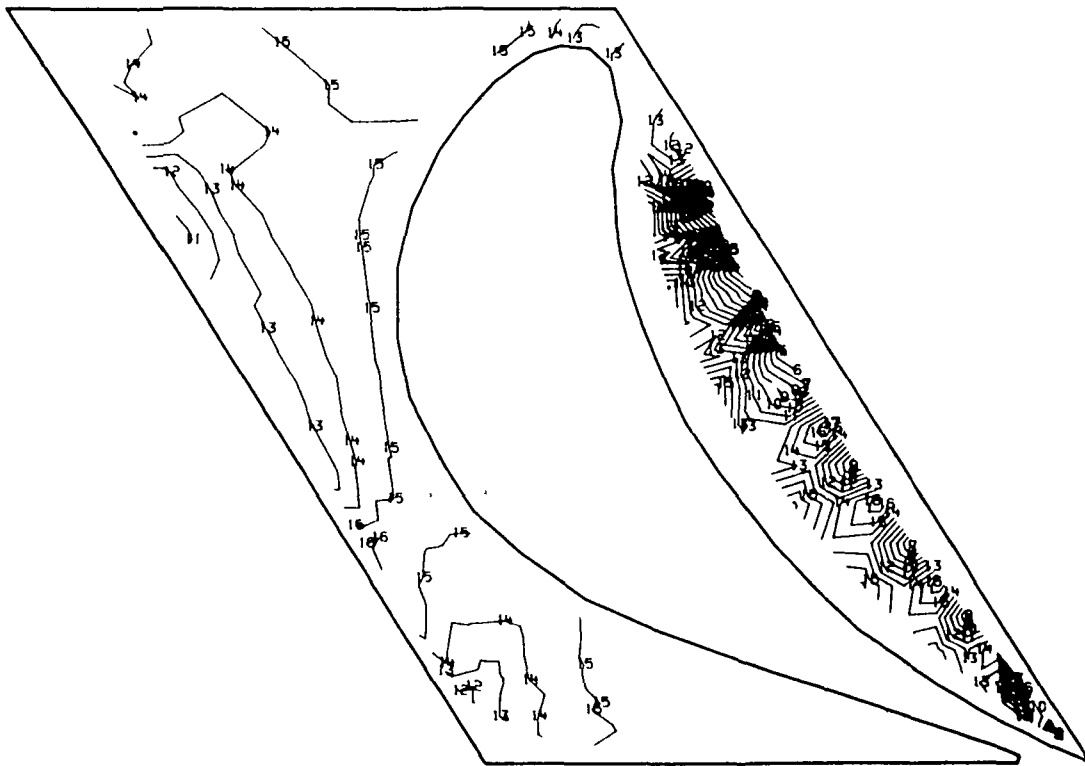

Fig. 3.3-29 Model F2, View 5, Hub Airfoil Side



1	-6.018010E 04	11	1.079076E 05
2	-4.337131E 04	12	1.247164E 05
3	-2.656253E 04	13	1.415251E 05
4	-9.753742E 03	14	1.583339E 05
5	7.055043E 03	15	1.751426E 05
6	2.386383E 04	16	1.919514E 05
7	4.067261E 04	17	2.087601E 05
8	5.748140E 04	18	2.255689E 05
9	7.429013E 04	19	2.423776E 05
10	9.109888E 04	20	2.591869E 05

Fig. 3.3-30 Model F2, View 5, FPL Load Major Principal Stress (psi)



1	-1.657864E 05	11	-5.222334E 04
2	-1.544306E 05	12	-4.087257E 04
3	-1.430748E 05	13	-2.951680E 04
4	-1.317189E 05	14	-1.316103E 04
5	-1.203631E 05	15	-6.805258E 03
6	-1.090073E 05	16	4.550512E 03
7	-9.765150E 04	17	1.590628E 04
8	-8.629569E 04	18	2.726205E 04
9	-7.493988E 04	19	3.861782E 04
10	-6.358411E 04	20	4.997327E 04

Fig. 3.3-31 Model F2, View 5, FPL Load, Minor Principal Stress (psi)

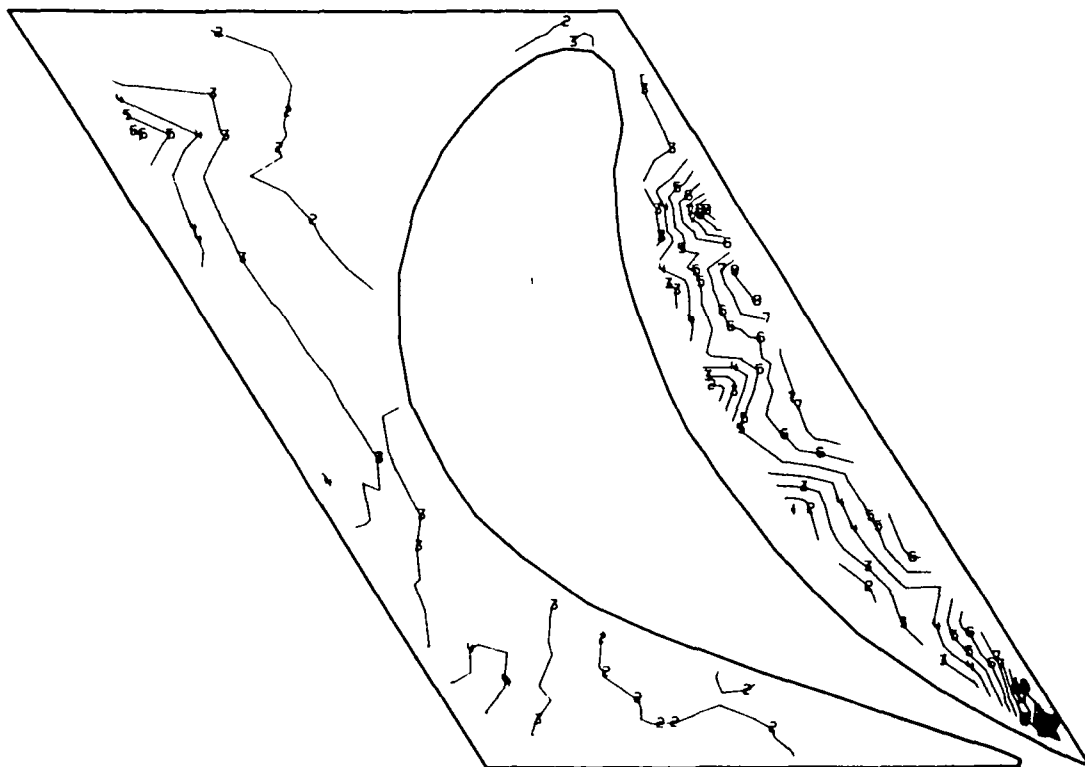

1	1.623115E 03	11	8.728900E 04
2	1.018971E 04	12	9.585556E 04
3	1.875632E 04	13	1.044221E 05
4	2.732292E 04	14	1.129887E 05
5	3.588952E 04	15	1.215553E 05
6	4.445612E 04	16	1.301218E 05
7	5.302272E 04	17	1.386884E 05
8	6.158932E 04	18	1.472549E 05
9	7.015588E 04	19	1.558215E 05
10	7.872244E 04	20	1.643886E 05

Fig. 3.3-32 Model F2, View 5, FPL Load, Shear Maximum Stress (psi)

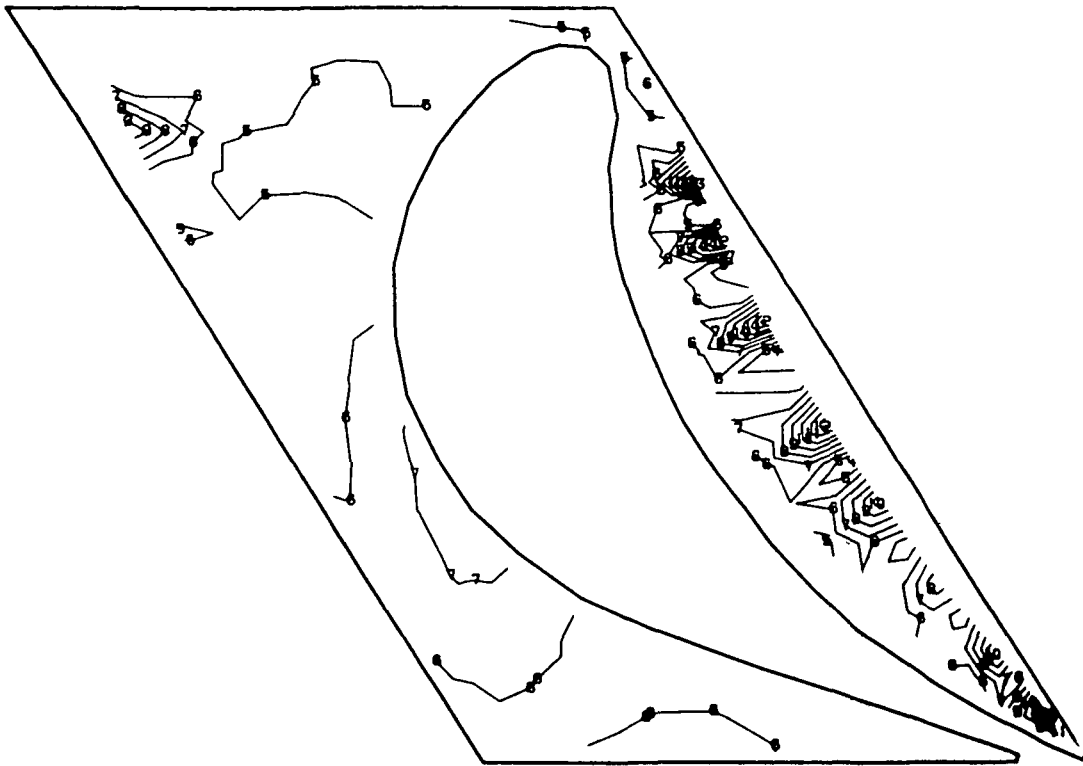

1	-5.800610E 04	11	1.044340E C5
2	-4.176208E 04	12	1.206780E C5
3	-2.551806E C4	13	1.369220E C5
4	-9.274043E C3	14	1.531660E C5
5	6.969977E C3	15	1.694100E C5
6	2.321400E C4	16	1.856540E C5
7	3.945802E C4	17	2.018980E C5
8	5.570204E 04	18	2.181420E C5
9	7.194600E C4	19	2.343860E C5
10	8.819000E C4	20	2.506304E C5

Fig. 3.3-33 Model F2, View 5, 115% Load, Major Principal Stress (psi)

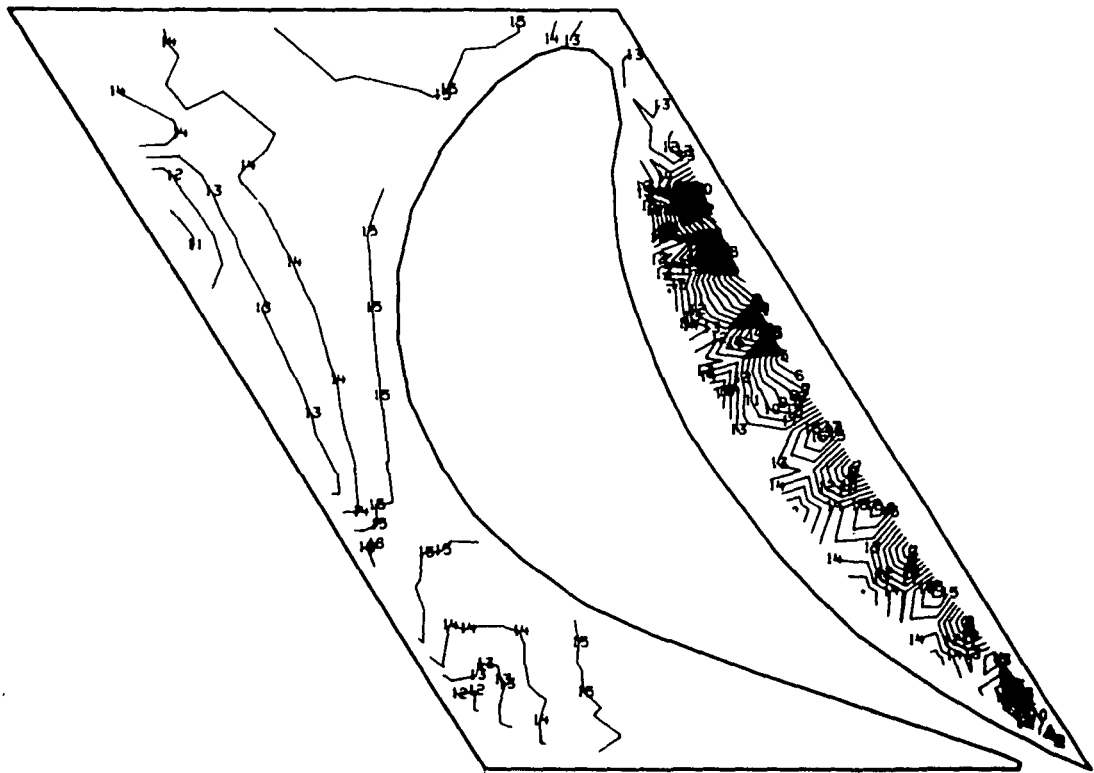

1	-1.588368E C5	11	-4.921443E C4
2	-1.478746E C5	12	-3.825224E C4
3	-1.369123E C5	13	-2.729005E C4
4	-1.259501E C5	14	-1.632786E C4
5	-1.149878E C5	15	-5.365664E C3
6	-1.040256E C5	16	5.595527E C3
7	-9.306331E C4	17	1.655872E C4
8	-8.210106E C4	18	2.752091E C4
9	-7.113881E C4	19	3.848310E C4
10	-6.017662E C4	20	4.944491E C4

Fig. 3.3-34 Model F2, View 5, FPL Load, Minimum Principal Stress (psi)

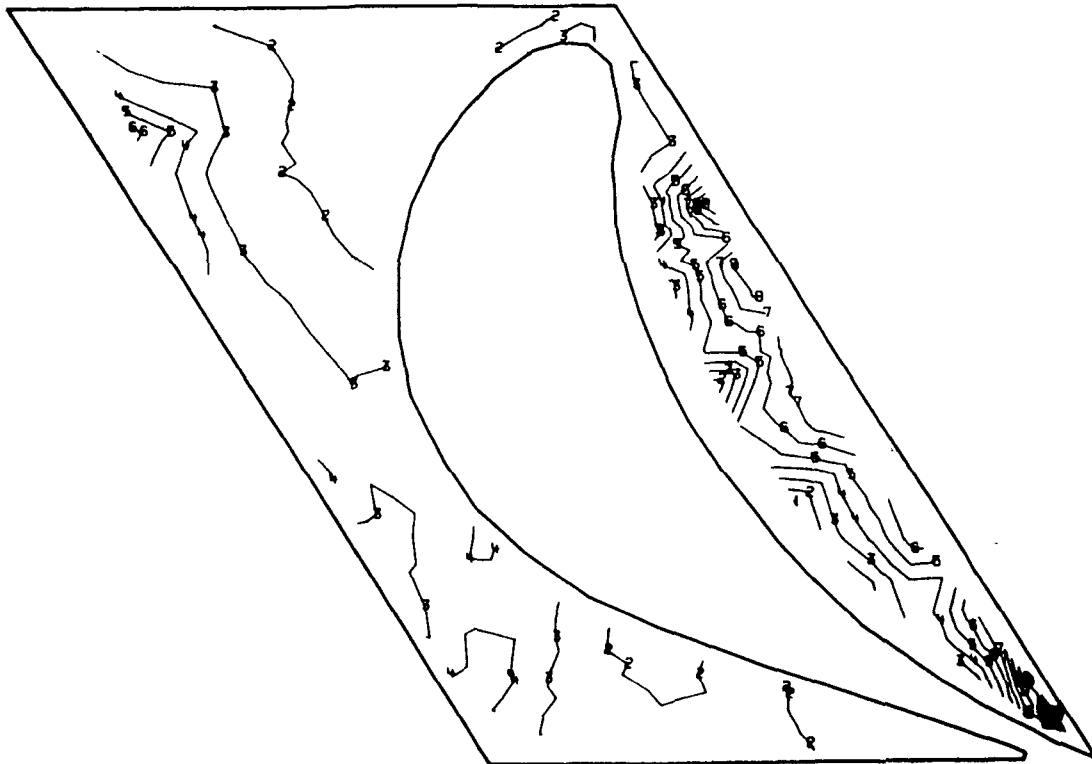

1	1.149C15E C3	11	8.366506E C4
2	9.400629E 03	12	9.191663E C4
3	1.765225E C4	13	1.001682E C5
4	2.590386E C4	14	1.084198E C5
5	3.415548E C4	15	1.166713E C5
6	4.240710E C4	16	1.249229E C5
7	5.065871E 04	17	1.331744E C5
8	5.891033E C4	18	1.414260E C5
9	6.716194E 04	19	1.496776E C5
10	7.541350E C4	20	1.579298E 05

Fig. 3.3-35 Model F2, View 5, 115% Load, Maximum Shear Stress (psi)

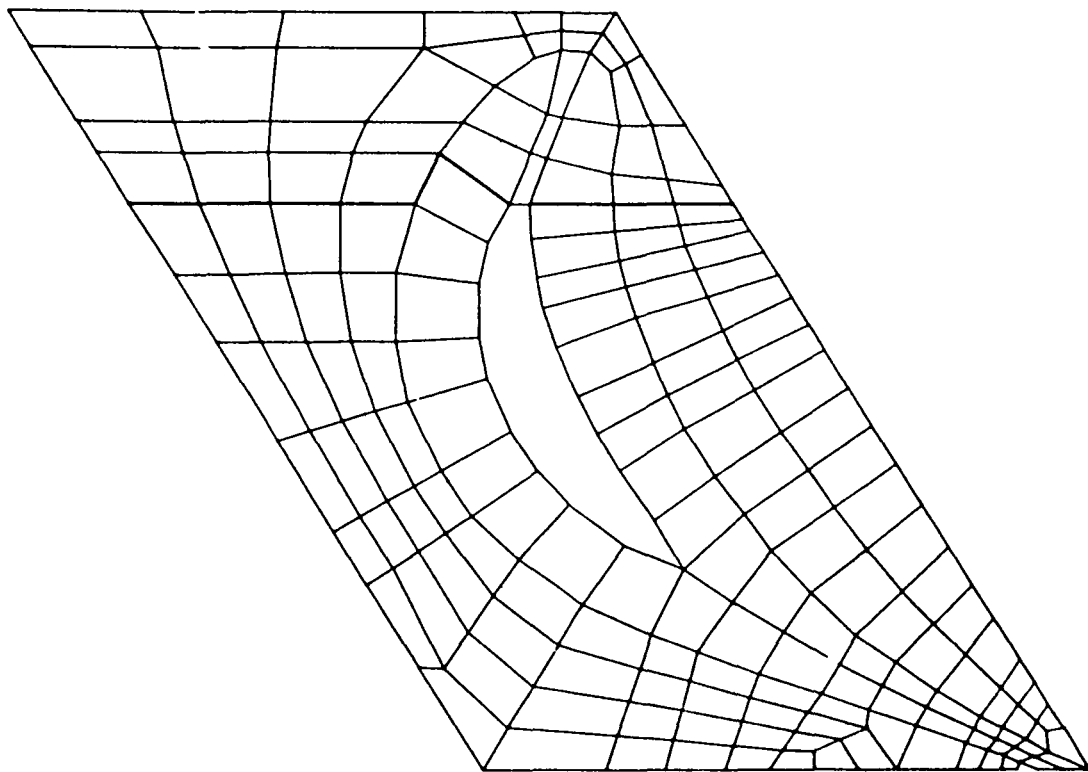
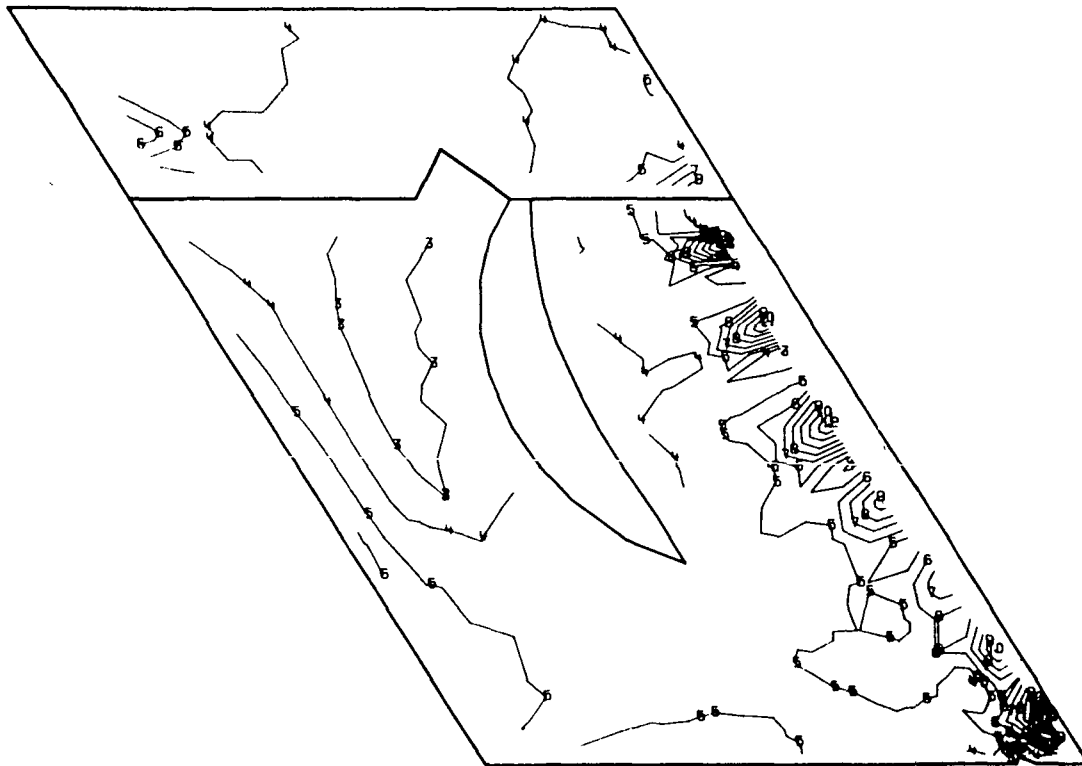
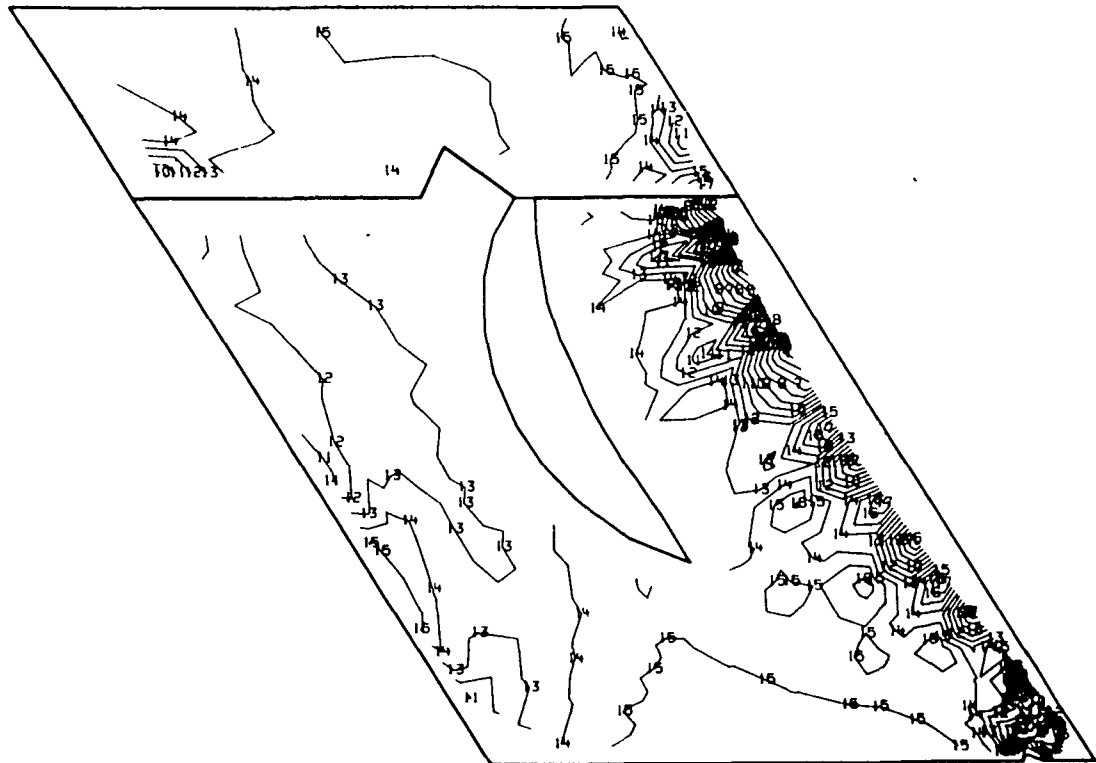

Fig. 3.3-36 Model F2, View 6, Hub Inner



1	-4.000594E 04	11	1.085536E 05
2	-2.510998E 04	12	1.238495E 05
3	-1.021402E 04	13	1.387454E 05
4	4.681934E 03	14	1.536414E 05
5	1.957789E 04	15	1.685373E 05
6	3.447385E 04	16	1.834333E 05
7	4.936980E 04	17	1.983292E 05
8	6.426576E 04	18	2.132251E 05
9	7.916169E 04	19	2.281211E 05
10	9.405763E 04	20	2.430173E 05

Fig. 3.3-37 Model F2, View 6, FPL Load Major Principal Stress (psi)



1	-1.565252E 05	05	11	-4.750028E 04	04
2	-1.456227E 05	05	12	-3.659783E 04	04
3	-1.347202E 05	05	13	-2.569538E 04	04
4	-1.238177E 05	05	14	-1.479292E 04	04
5	-1.129152E 05	05	15	-3.890469E 03	03
6	-1.020127E 05	05	16	7.011984E 03	03
7	-9.111019E 04	04	17	1.791444E 04	04
8	-8.020769E 04	04	18	2.881689E 04	04
9	-6.930519E 04	04	19	3.971934E 04	04
10	-5.840273E 04	04	20	5.062146E 04	04

Fig. 3.3-38 Model F2, View 6, FPL Load, Minor Principal Stress (psi)

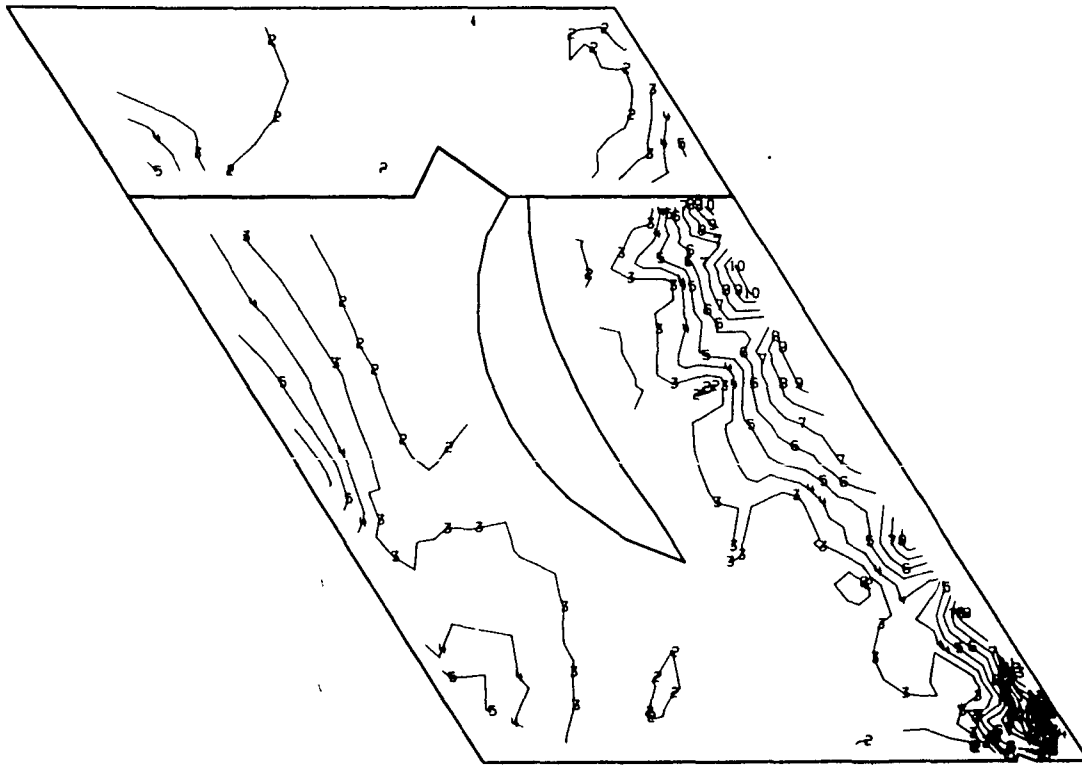

1	3.952041E 02	11	7.365294E 04
2	7.720980E 03	12	8.097869E 04
3	1.504676E 04	13	8.830444E 04
4	2.237254E 04	14	9.563019E 04
5	2.969831E 04	15	1.029559E 05
6	3.702409E 04	16	1.102317E 05
7	4.434987E 04	17	1.176074E 05
8	5.167564E 04	18	1.249332E 05
9	5.900142E 04	19	1.322589E 05
10	6.632719E 04	20	1.395851E 05

Fig. 3.3-39 Model F2, View 6, FPL Load, Shear Maximum Stress (psi)

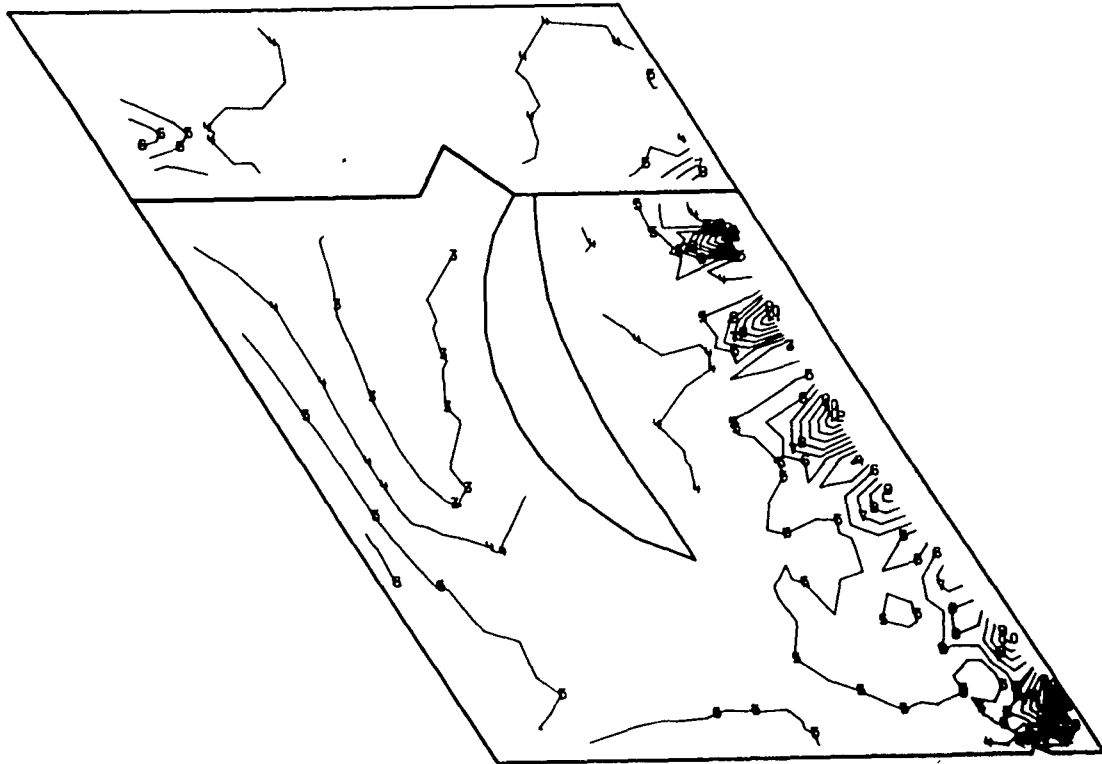

1	-2.786293E C4	11	1.060093E C5
2	-2.347569E 04	12	1.203965E 05
3	-5.088449E C3	13	1.347837E C5
4	5.298789E C3	14	1.491709E C5
5	1.968603E C4	15	1.625581E C5
6	3.407327E C4	16	1.779453E C5
7	4.846050E C4	17	1.923324E 05
8	6.284774E C4	18	2.067196E C5
9	7.723494E C4	19	2.211068E C5
10	9.162213E C4	20	2.354947E C5

Fig. 3.3-40 Model F2, View 6, 115% Load, Maximum Shear Stress (psi)

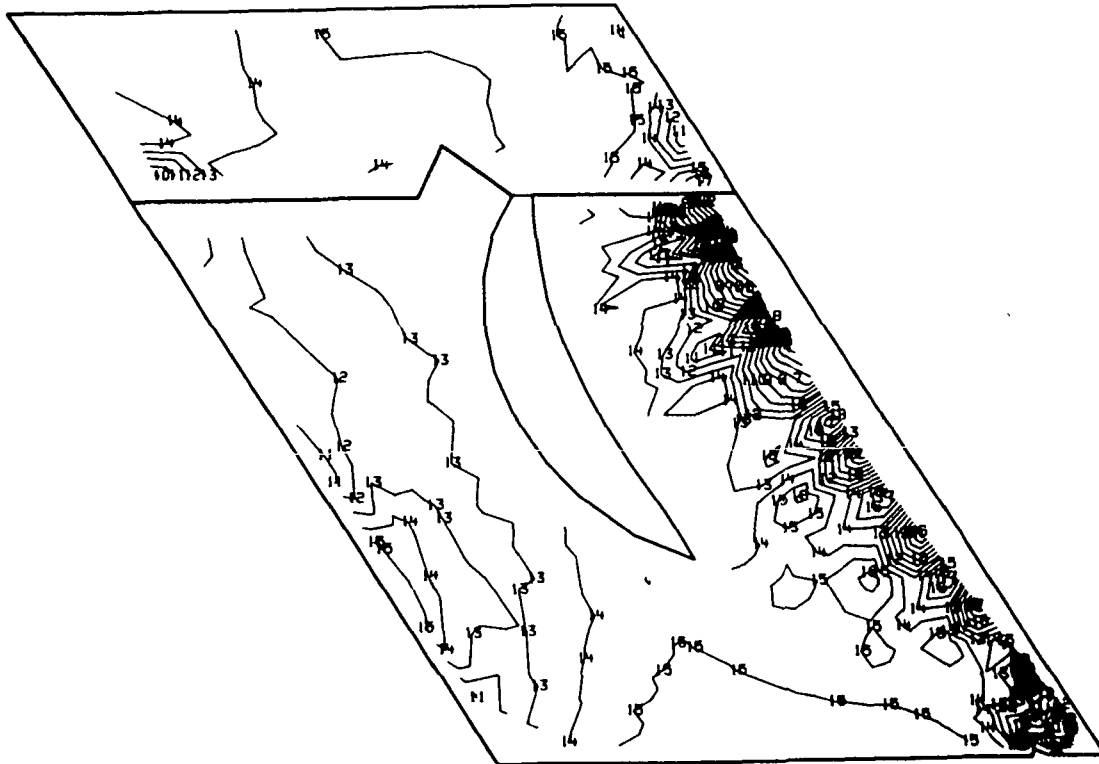

1	-1.511581E C5	11	-4.588496E C4
2	-1.406108E 05	12	-2.512766E C4
3	-1.300634E C5	13	-2.459036E 04
4	-1.195161E C5	14	-1.404306E C4
5	-1.089688E C5	15	-2.495758E C3
6	-9.842150E C4	16	7.051543E C3
7	-8.787419E C4	17	1.759884E C4
8	-7.732688E C4	18	2.814614E 04
9	-6.677956E 04	19	2.889345E C4
10	-5.623226E C4	20	4.924071E 04

Fig. 3.3-41 Model F2, View 6, 115% Load, Minor Principal Stress (psi)

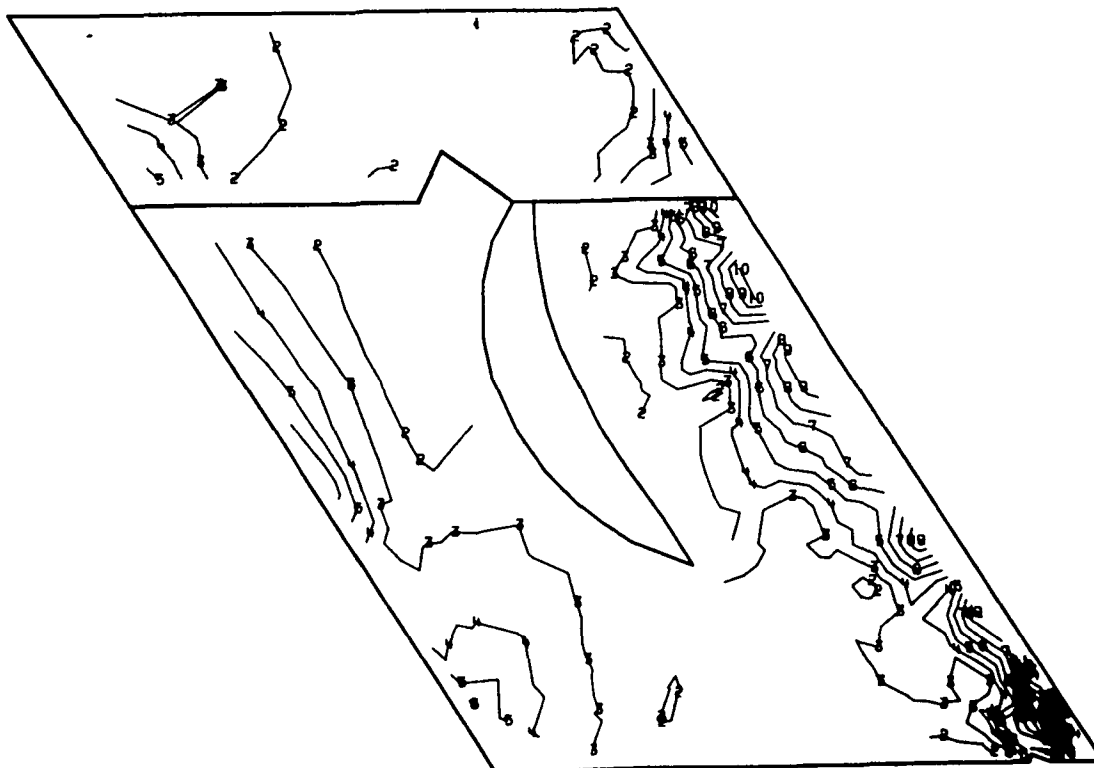

1	4.155405E C2	11	7.047494E C4
2	7.422383E C3	12	7.748075E C4
3	1.442823E C4	13	8.448656E C4
4	2.143407E C4	14	9.149238E C4
5	2.843991E C4	15	9.849819E C4
6	3.544576E C4	16	1.055040E C5
7	4.245160E C4	17	1.125098E C5
8	4.945745E C4	18	1.195156E C5
9	5.646329E C4	19	1.265214E C5
10	6.346913E C4	20	1.335276E C5

Fig. 3.3-42 Model F2, View 1, 115% Load, Maximum Shear Stress (psi)

3.4 HPOTP FIRST STAGE NOZZLES STRESSES AT FPL AND 115% RPL

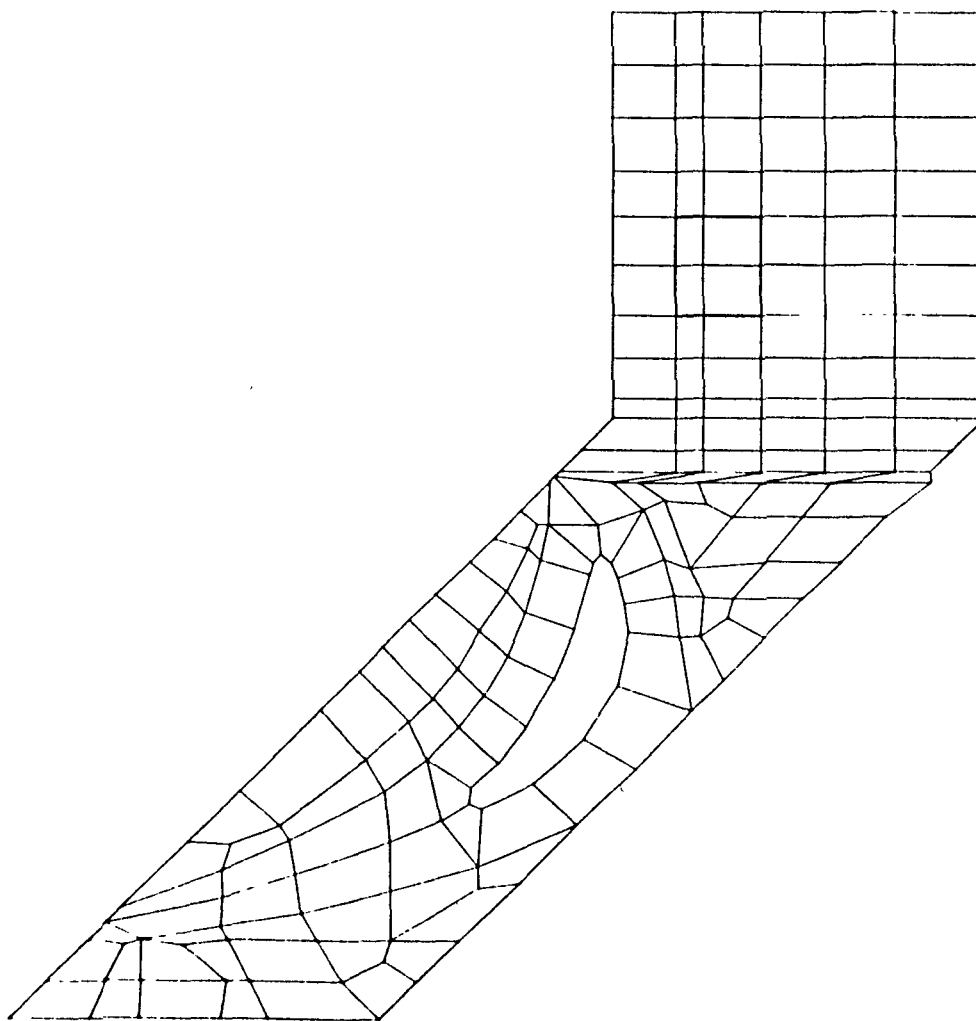
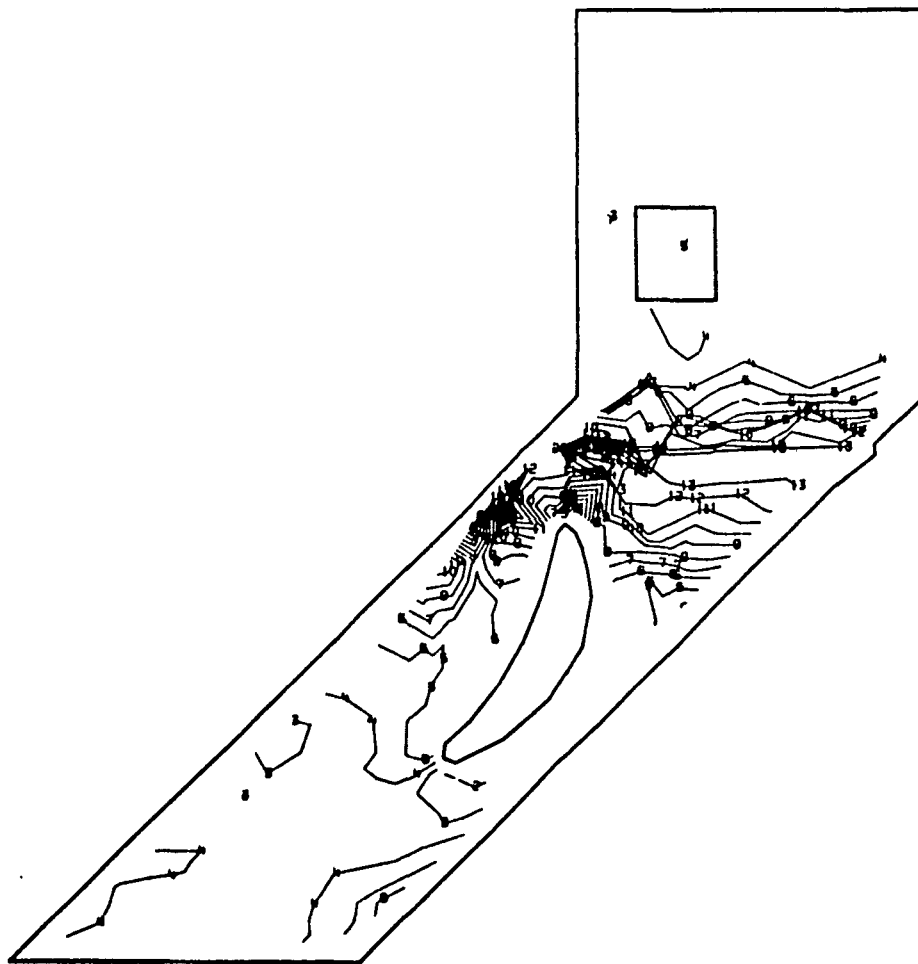
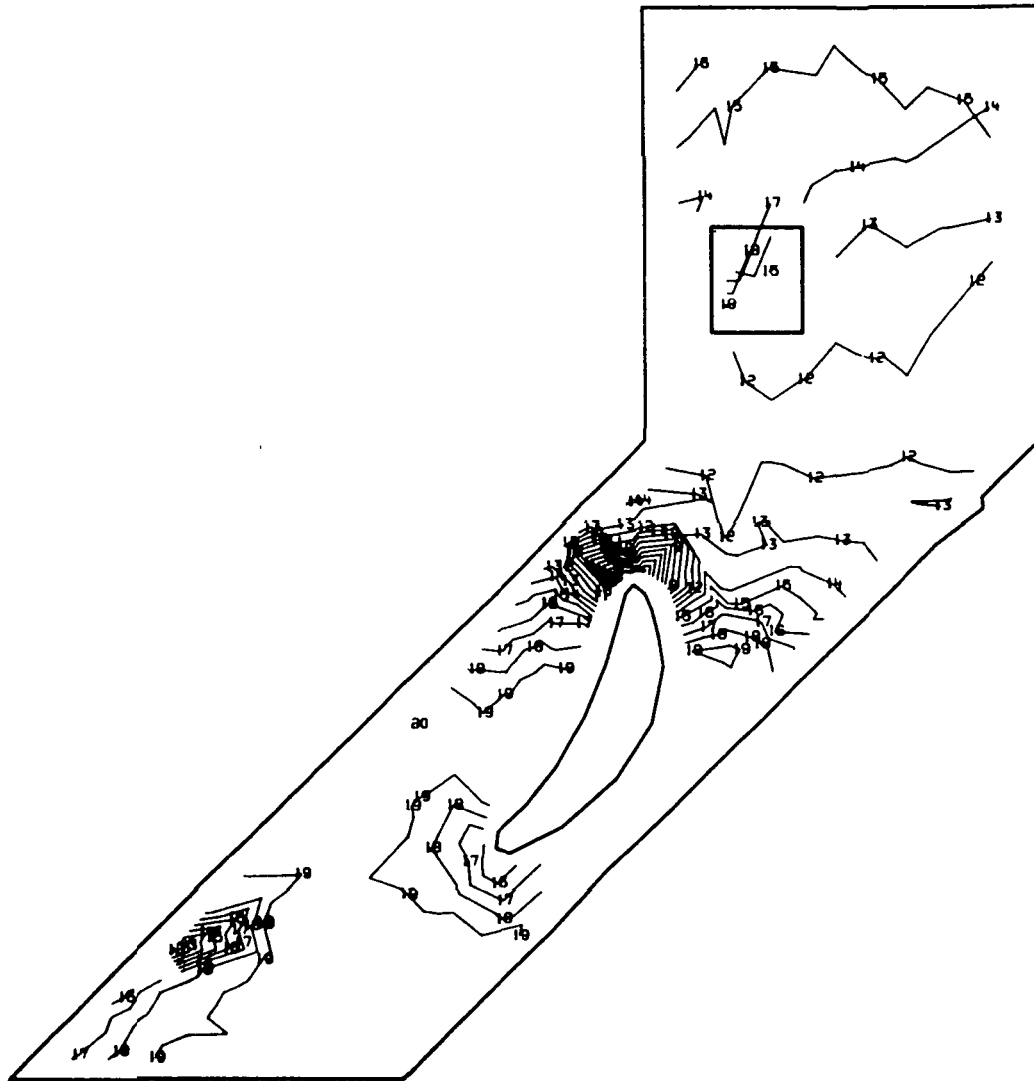

Fig. 3.4-1 Model 01, View 1, Shroud Outside



1	-3.222034E C4	11	1.393453E C5
2	-1.506377E C4	12	1.565019E 05
3	2.092809E C3	13	1.736584E C5
4	1.924938E C4	14	1.908150E C5
5	3.640596E C4	15	2.079716E C5
6	5.356252E 04	16	2.251281E C5
7	7.071906E C4	17	2.422847E 05
8	8.787563E 04	18	2.594413E C5
9	1.050222E C5	19	2.765978E C5
10	1.221888E C5	20	2.927546E C5

Fig. 3.4-2 Model 01, FPL Load, View 1, Major Principal Stress (psi)



1	-4.896866E C5	11	-2.271416E C5
2	-4.634321E C5	12	-2.008871E C5
3	-4.371776E C5	13	-1.746326E C5
4	-4.109231E C5	14	-1.483781E C5
5	-3.846686E C5	15	-1.221236E C5
6	-3.584141E C5	16	-9.586906E C4
7	-3.321596E C5	17	-6.981456E C4
8	-3.059051E C5	18	-4.326010E C4
9	-2.796506E C5	19	-1.710563E C4
10	-2.533961E C5	20	9.148332E C3

Fig. 3.4-3 Model 01, FPL Load, View 1, Minor Principal Stress (psi)

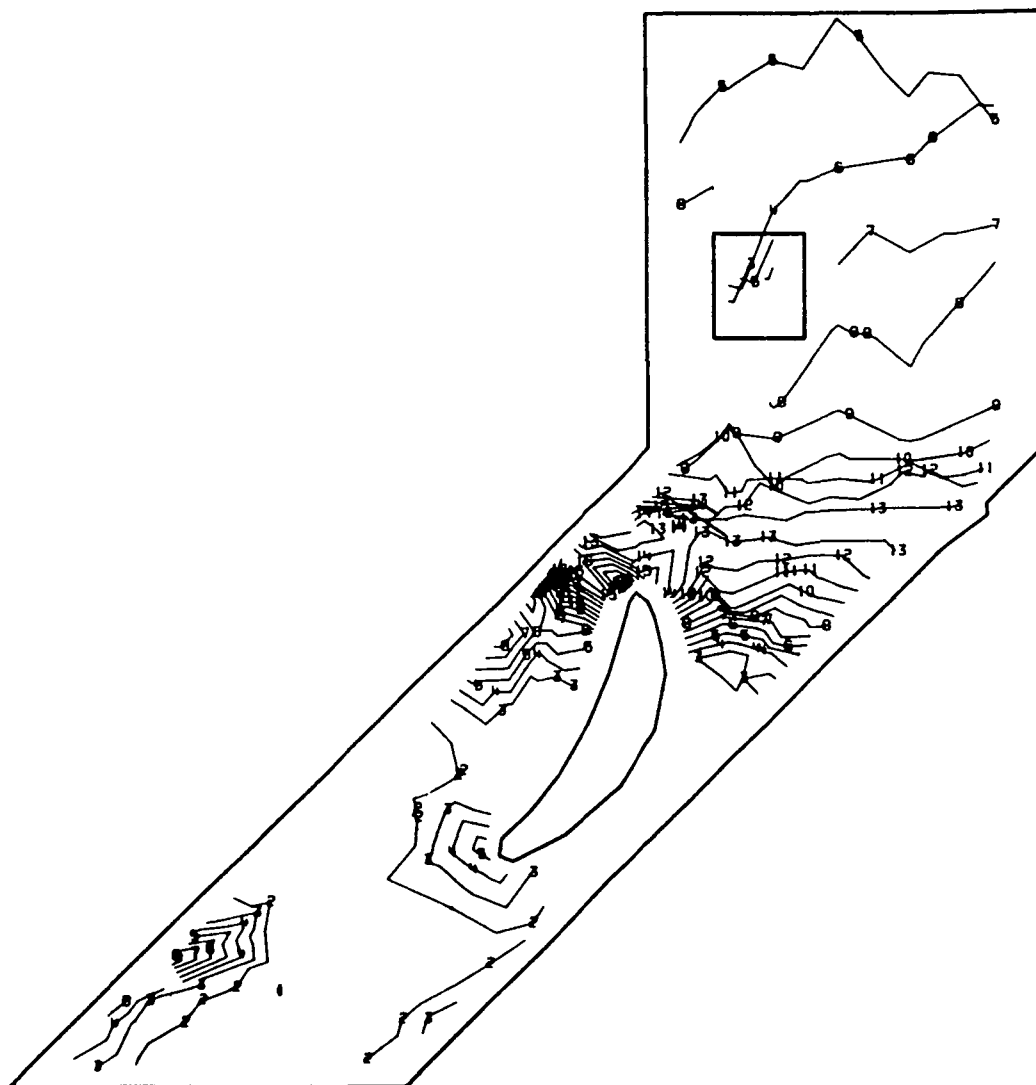

1	3.451605E C3	11	1.483261E C5
2	1.793907E C4	12	1.628135E C5
3	3.242653E C4	13	1.773009E C5
4	4.691399E C4	14	1.917884E C5
5	6.140145E C4	15	2.062758E C5
6	7.588888E C4	16	2.207633E C5
7	9.037621E C4	17	2.352507E C5
8	1.048638E C5	18	2.497381E C5
9	1.193512E C5	19	2.642256E C5
10	1.338366E C5	20	2.787134E C5

Fig. 3.4-4 Model 01, FPL Load, View 1, Maximum Principal Shear (psi)

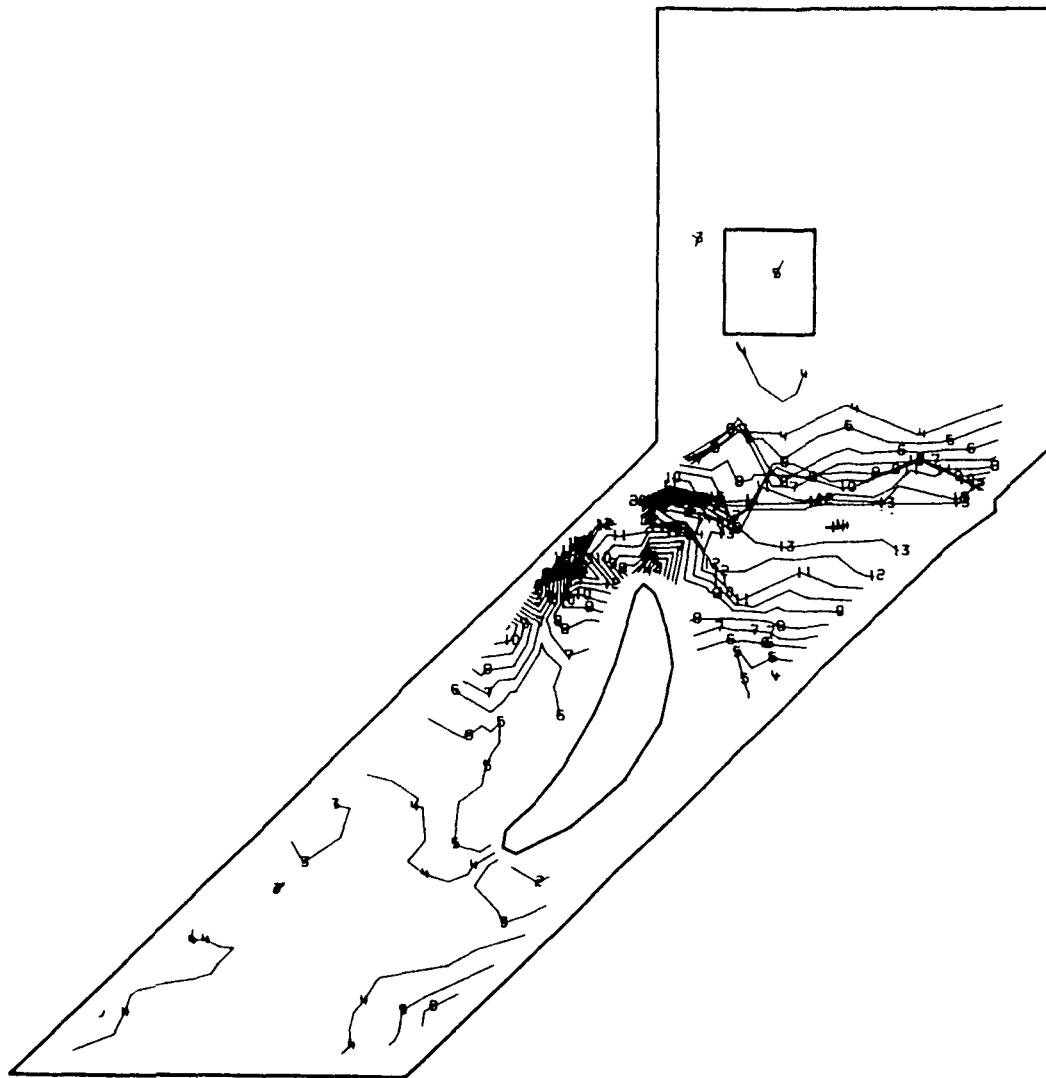

1	-3.632557E 04	11	1.585904E 05
2	-1.683395E 04	12	1.780819E 05
3	2.657664E 03	13	1.975735E 05
4	2.214928E 04	14	2.170651E 05
5	4.164090E 04	15	2.365566E 05
6	6.113252E 04	16	2.560482E 05
7	8.062413E 04	17	2.755398E 05
8	1.001157E 05	18	2.950313E 05
9	1.196073E 05	19	3.145229E 05
10	1.390988E 05	20	3.340152E 05

Fig. 3.4-5 Model 01, View 1, 115% Load, Major Principal Stress (psi)

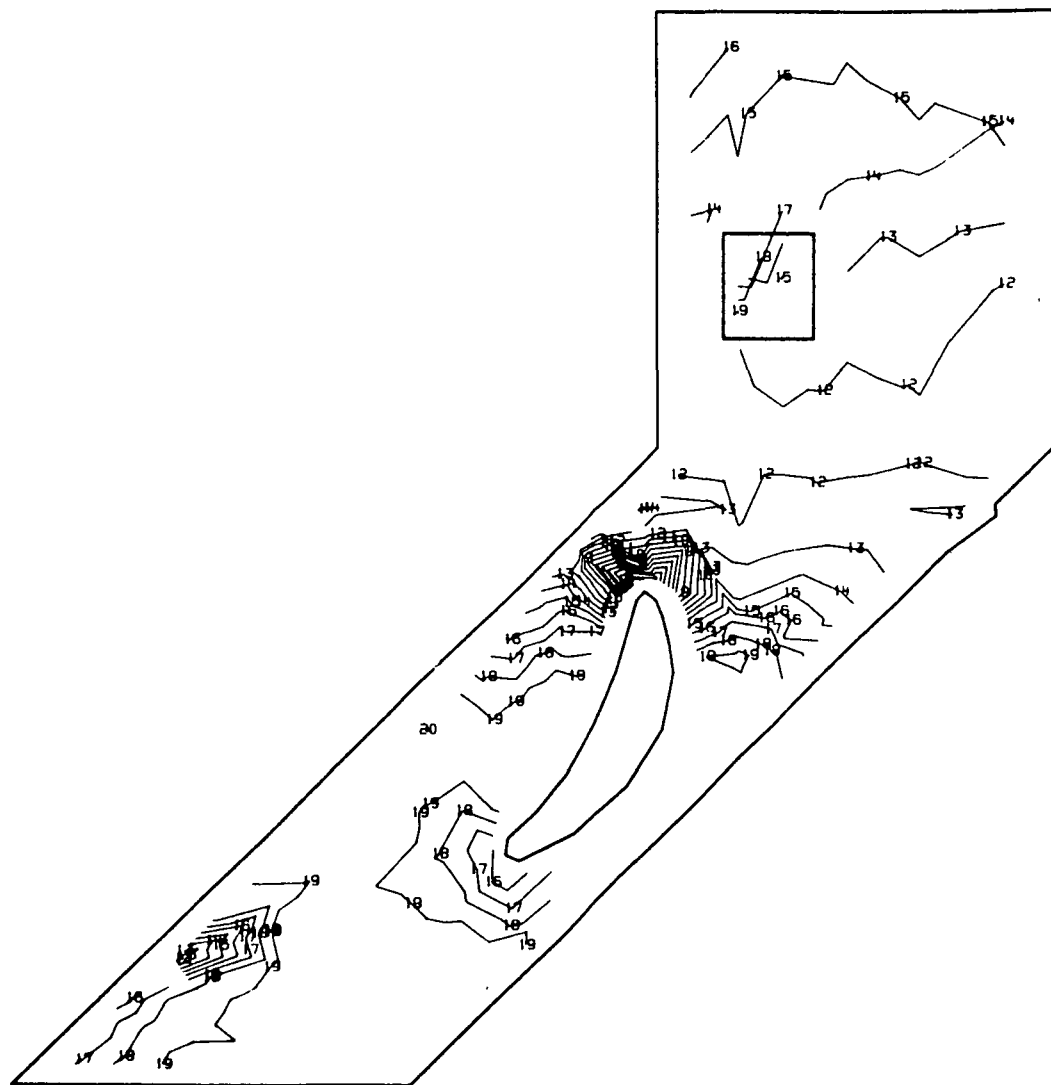

1	-5.719487E 05	11	-2.652831E 05
2	-5.412821E 05	12	-2.346165E 05
3	-5.106156E 05	13	-2.039499E 05
4	-4.799490E 05	14	-1.732834E 05
5	-4.492824E 05	15	-1.426168E 05
6	-4.186159E 05	16	-1.119503E 05
7	-3.879493E 05	17	-8.128369E 04
8	-3.572828E 05	18	-5.061716E 04
9	-3.266162E 05	19	-1.995063E 04
10	-2.959496E 05	20	1.071539E 04

Fig. 3.4-6 Model 01, View 1, 115% Load, Minor Principal Stress (psi)

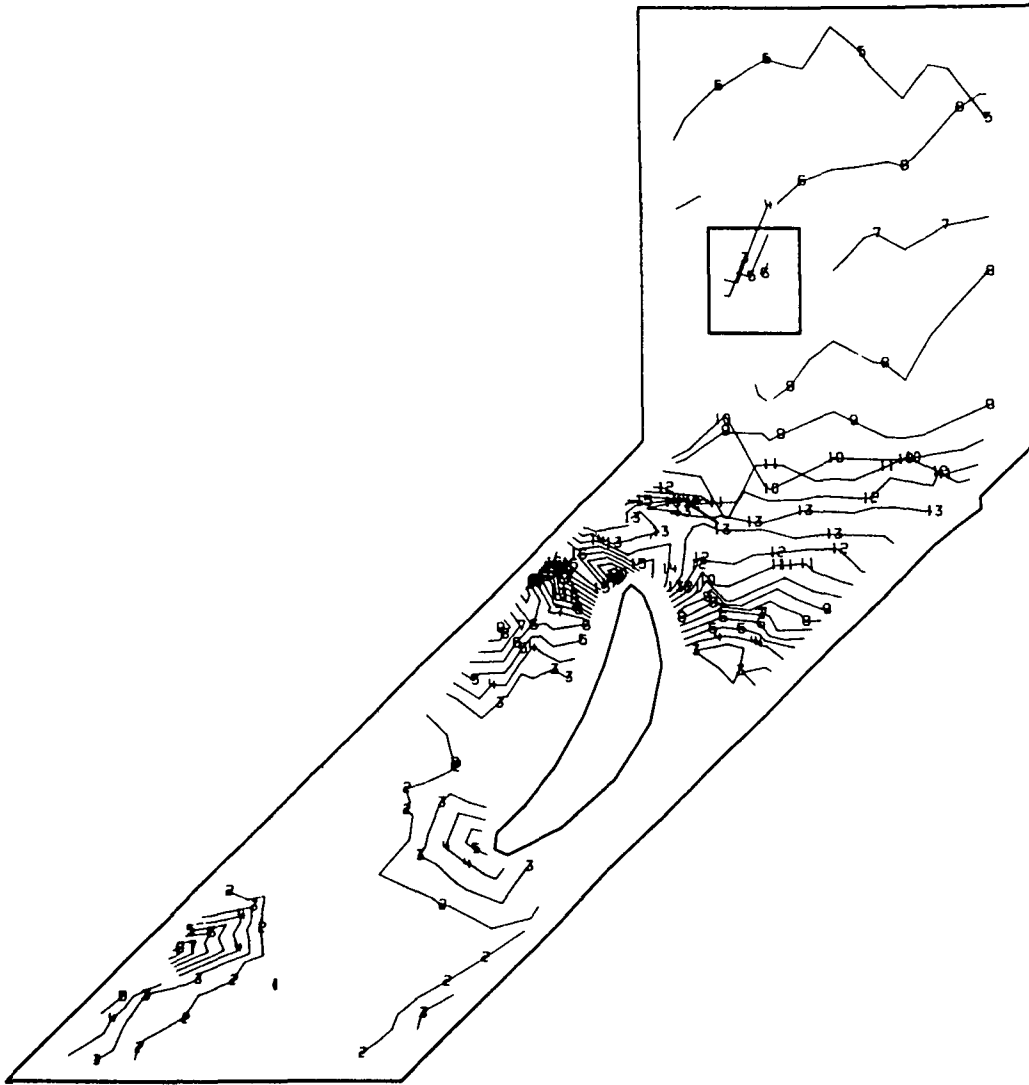

1	3.684479E 03	11	1.741922E 05
2	2.073528E 04	12	1.912429E 05
3	3.778609E 04	13	2.082937E 05
4	5.483689E 04	14	2.253444E 05
5	7.188769E 04	15	2.423952E 05
6	8.893844E 04	16	2.594459E 05
7	1.059892E 05	17	2.764967E 05
8	1.230399E 05	18	2.935474E 05
9	1.400907E 05	19	3.105982E 05
10	1.571414E 05	20	3.276498E 05

Fig. 3.4-7 Model 01, View 1, 115% Load, Shear Maximum Stress (psi)

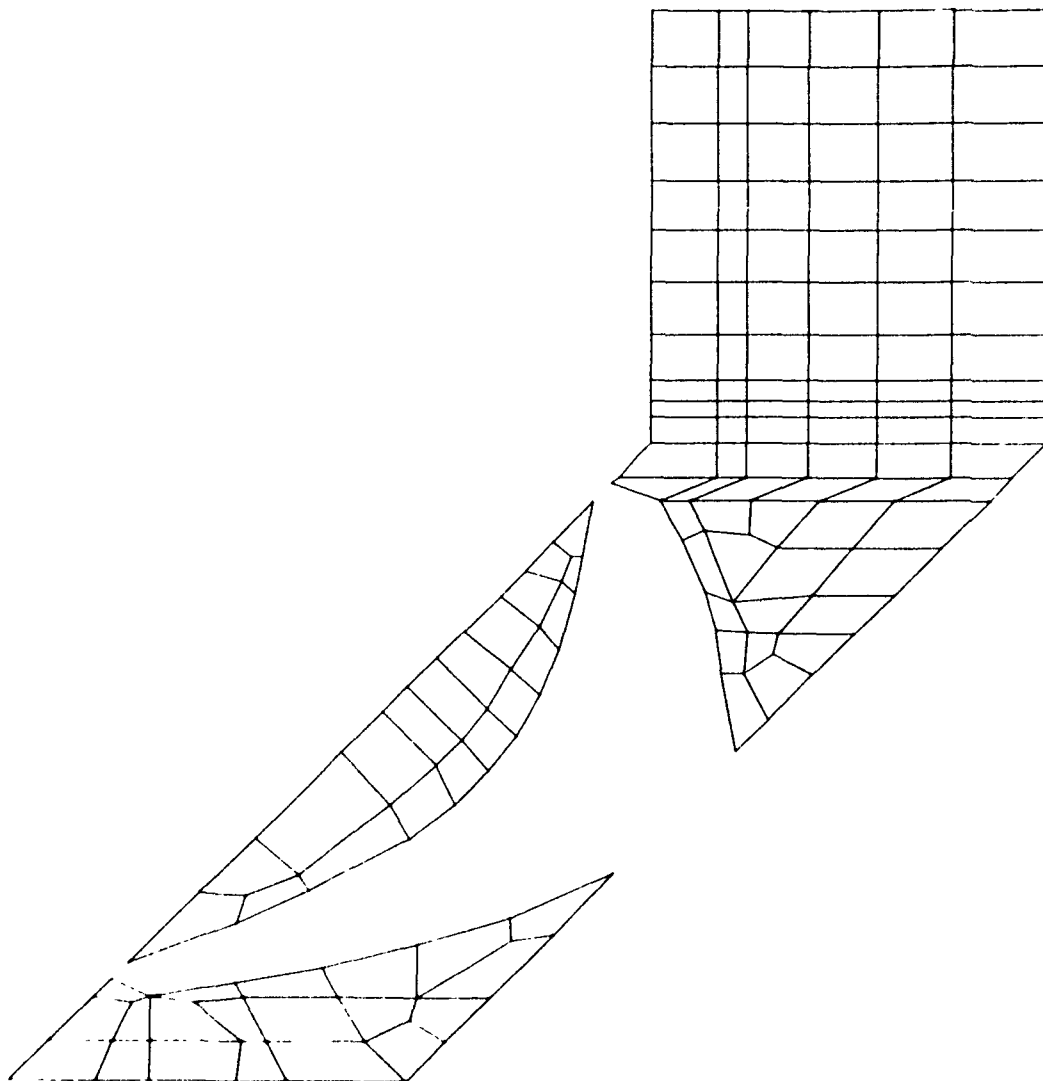
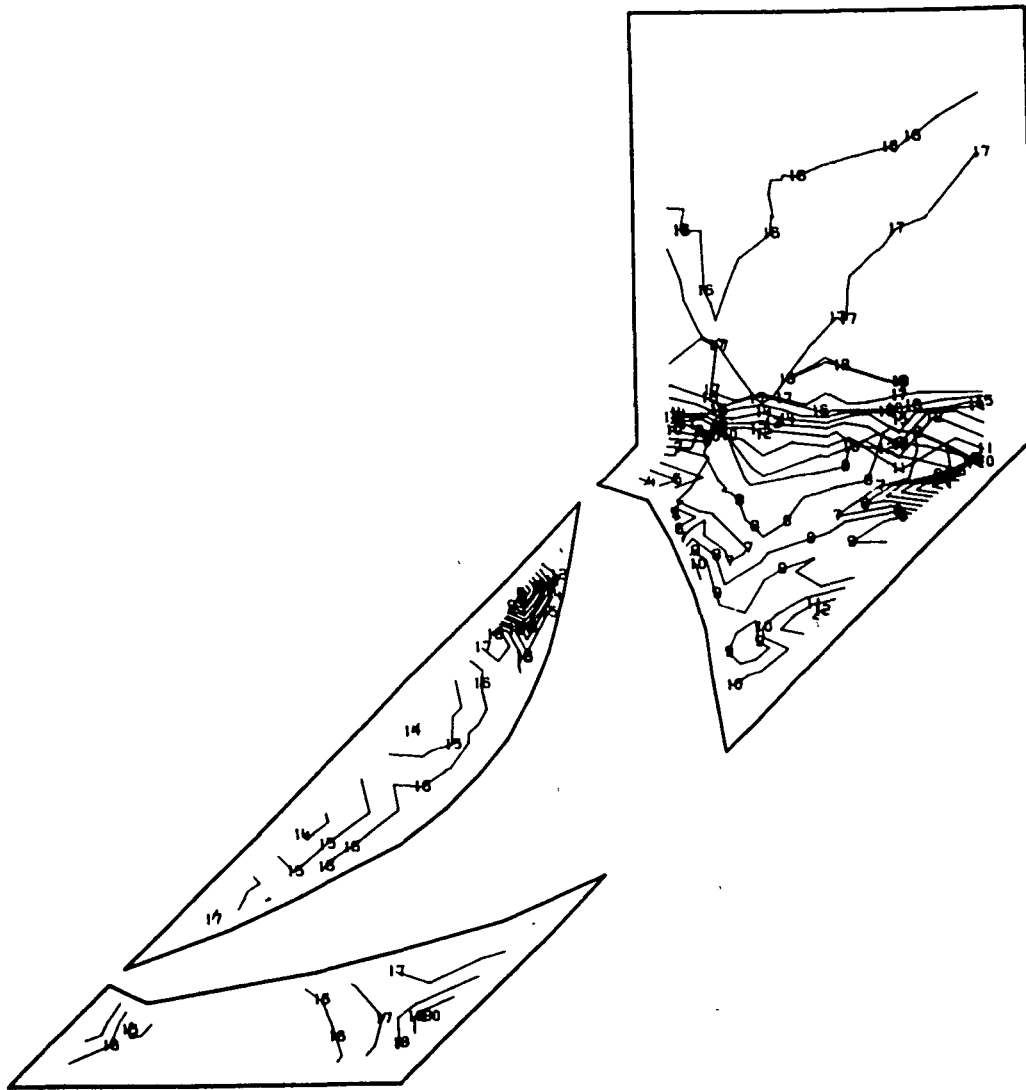
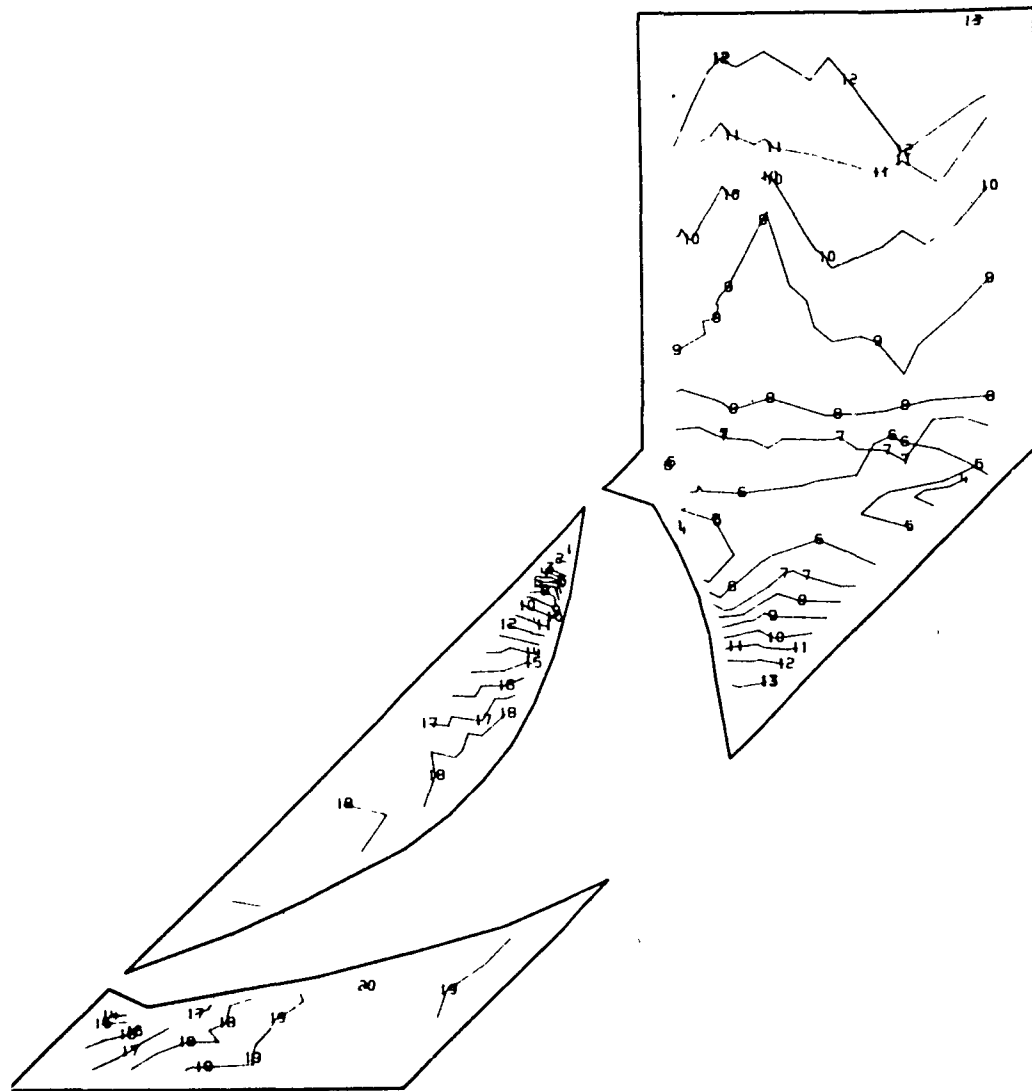

Fig. 3.4-8 Model 01, View 2, Shroud Foil Side



1	-1.742224E C5	11	-4.785067E C4
2	-1.615853E C5	12	-2.521354E C4
3	-1.489481E C5	13	-2.257641E C4
4	-1.363109E C5	14	-9.939273E C3
5	-1.236737E C5	15	2.697859E C3
6	-1.110365E C5	16	1.533499E C4
7	-9.839931E C4	17	2.797213E C4
8	-8.576213E C4	18	4.060926E C4
9	-7.312494E C4	19	5.324639E C4
10	-6.048790E C4	20	6.588313E C4

Fig. 3.4-9 Model 01, FPL Load, View 2, Major Principal Stress (psi)



1	-2.491578E C5	11	-1.591428E C5
2	-3.301563E C5	12	-1.401413E C5
3	-3.111548E C5	13	-1.211398E C5
4	-2.921533E C5	14	-1.021383E C5
5	-2.731518E C5	15	-8.313675E C4
6	-2.541503E C5	16	-6.413530E C4
7	-2.351488E C5	17	-4.513384E C4
8	-2.161473E C5	18	-2.613239E C4
9	-1.971458E C5	19	-7.120938E C3
10	-1.781443E C5	20	1.186991E C4

Fig. 3.4-10 Model 01, FPL Load, View 2, Minor Principal Stress (psi)

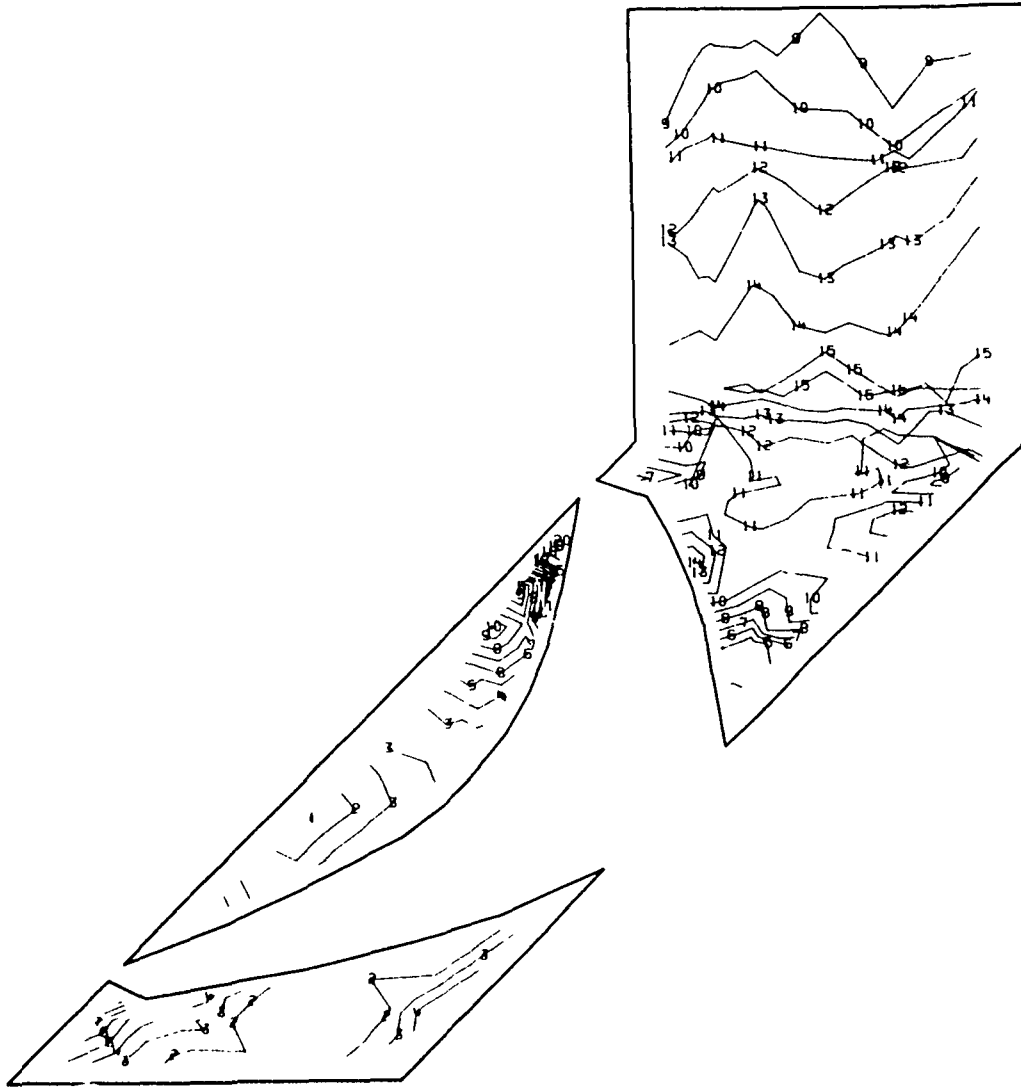

1	2.230542E C3	11	8.749175E C4
2	1.075666E C4	12	9.601788E O4
3	1.928279E C4	13	1.045440E C5
4	2.780891E O4	14	1.130701E C5
5	3.633504E C4	15	1.215963E C5
6	4.486116E O4	16	1.301224E C5
7	5.338729E C4	17	1.386485E C5
8	6.191341E C4	18	1.471746E C5
9	7.043950E C4	19	1.557008E C5
10	7.896563E C4	20	1.642270E C5

Fig. 3.4-11 Model 01, FPL Load, View 2, Maximum Principal Shear (psi)

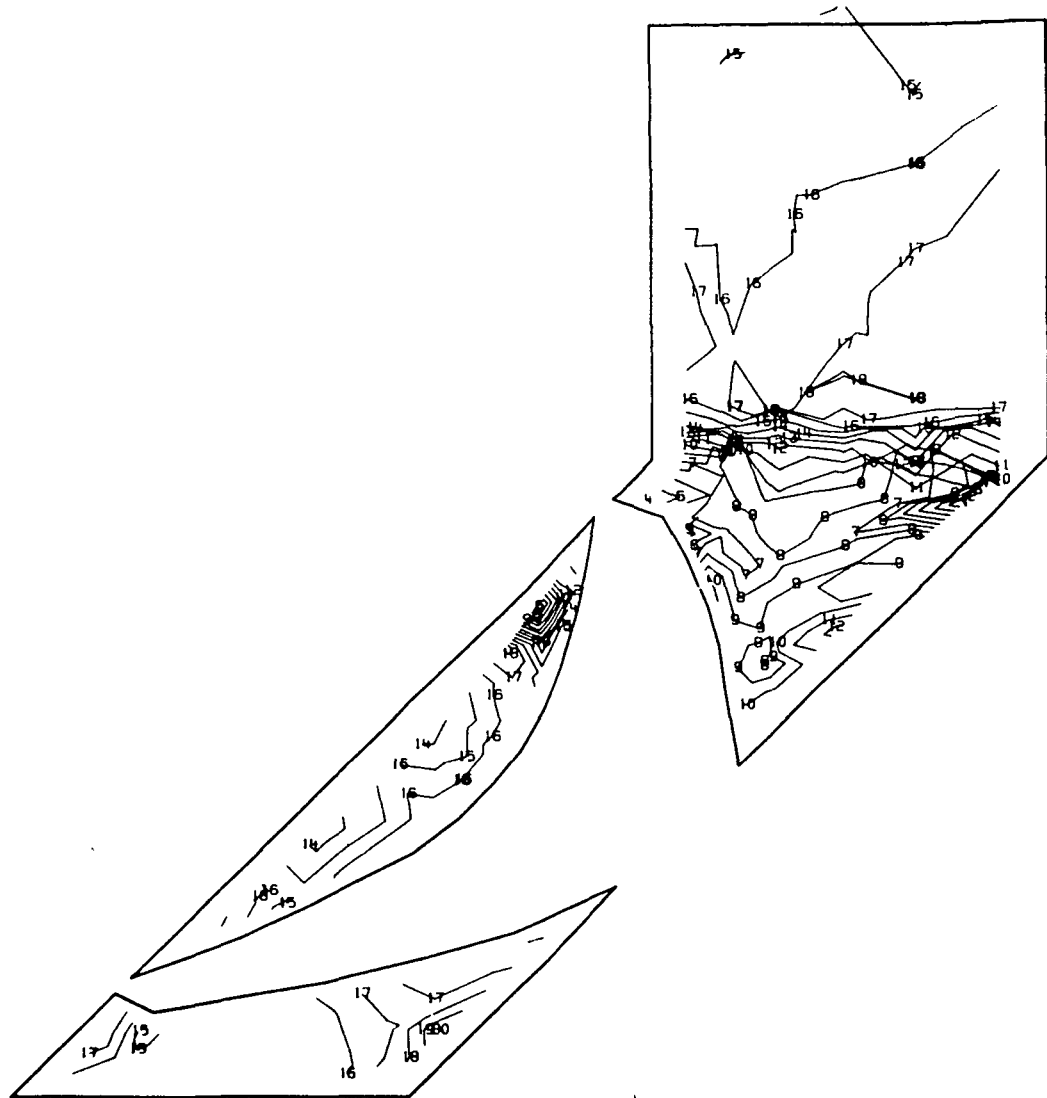

1	-1.952723E 05	11	-5.278540E 04
2	-1.810236E 05	12	-3.853673E 04
3	-1.667749E 05	13	-2.428807E 04
4	-1.525262E 05	14	-1.003941E 04
5	-1.382775E 05	15	4.205258E 03
6	-1.240288E 05	16	1.845792E 04
7	-1.097801E 05	17	3.270659E 04
8	-9.553144E 04	18	4.695525E 04
9	-8.128275E 04	19	6.120391E 04
10	-6.703406E 04	20	7.545238E 04

Fig. 3.4-12 Model 01, View 2, 115% Load, Major Principal Stress (psi)

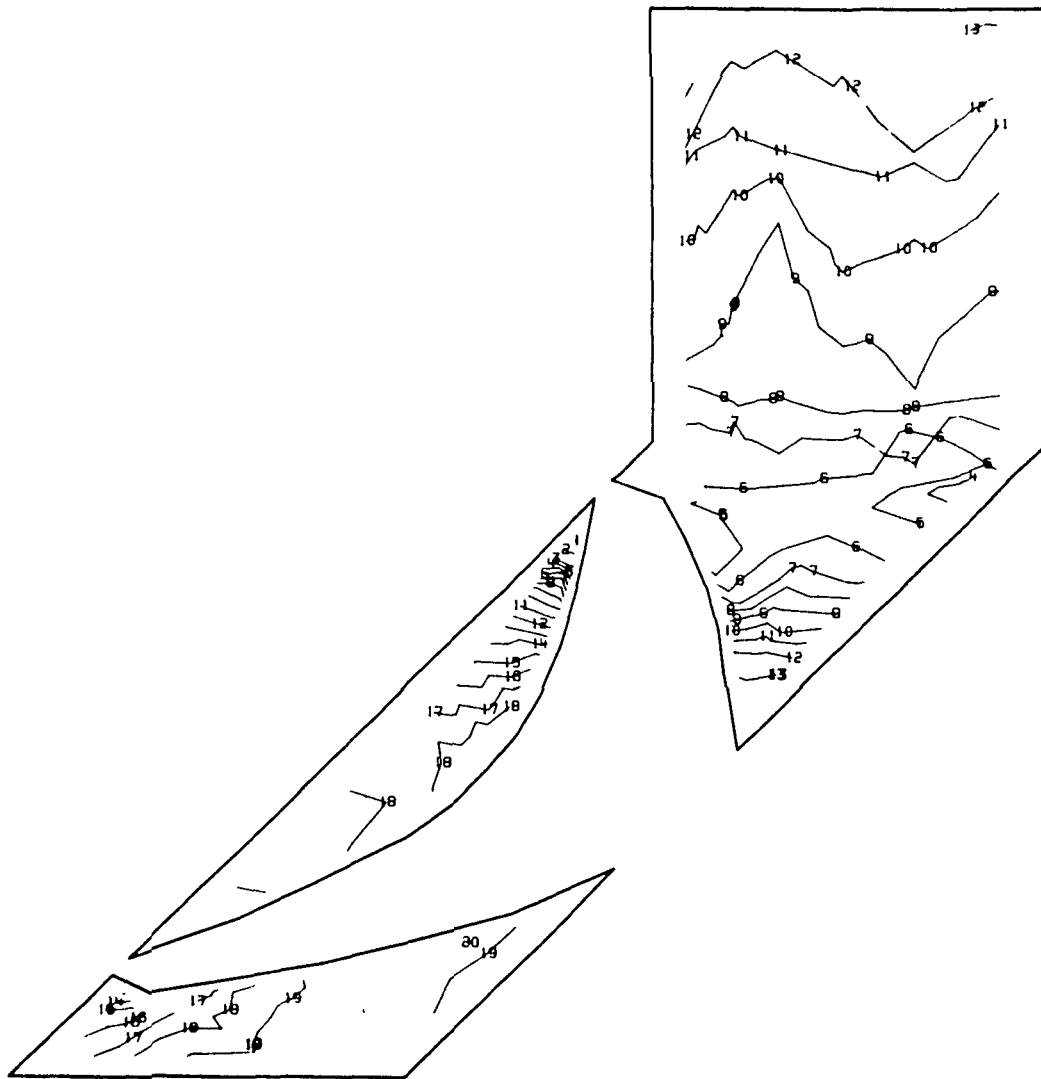

1	-4.066226E 05	11	-1.856126E 05
2	-3.845216E 05	12	-1.635116E 05
3	-3.624206E 05	13	-1.414106E 05
4	-3.403196E 05	14	-1.193096E 05
5	-3.182186E 05	15	-9.720863E 04
6	-2.961176E 05	16	-7.510763E 04
7	-2.740166E 05	17	-5.300663E 04
8	-2.519156E 05	18	-3.090563E 04
9	-2.298146E 05	19	-8.804637E 03
10	-2.077136E 05	20	1.325636E 04

Fig. 3.4-13 Model 01, View 2, 115% Load, Minor Principal Stress (psi)

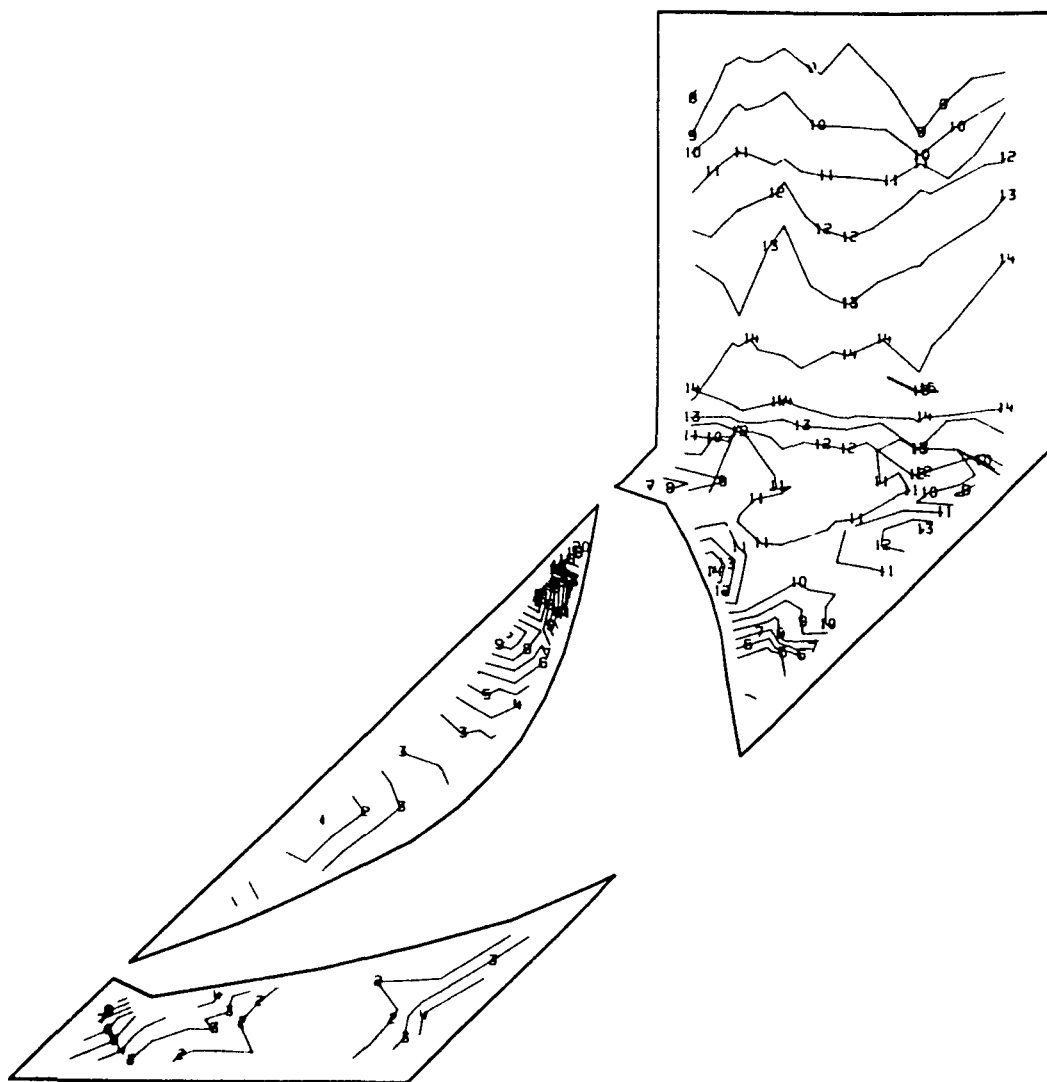

1	2.529718E 03	11	1.030587E 05
2	1.258263E 04	12	1.131116E 05
3	2.263554E 04	13	1.231644E 05
4	3.268846E 04	14	1.332173E 05
5	4.274137E 04	15	1.432702E 05
6	5.279429E 04	16	1.533231E 05
7	6.284720E 04	17	1.633759E 05
8	7.290006E 04	18	1.734288E 05
9	8.295294E 04	19	1.834817E 05
10	9.300581E 04	20	1.935351E 05

Fig. 3.4-14 Model 01, View 2, 115% Load, Shear Maximum Stress (psi)

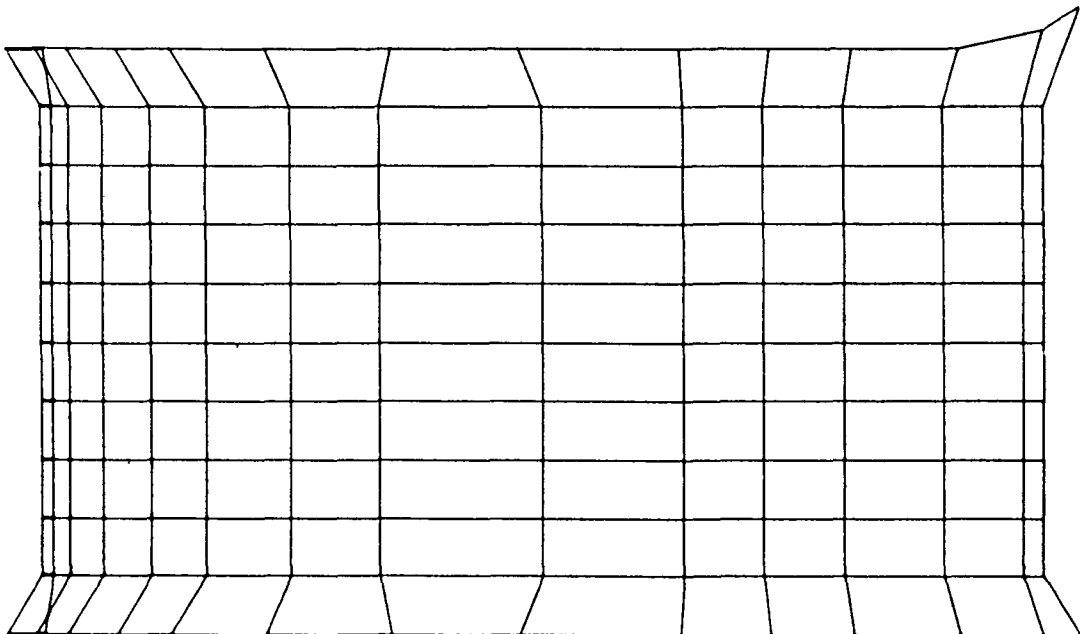
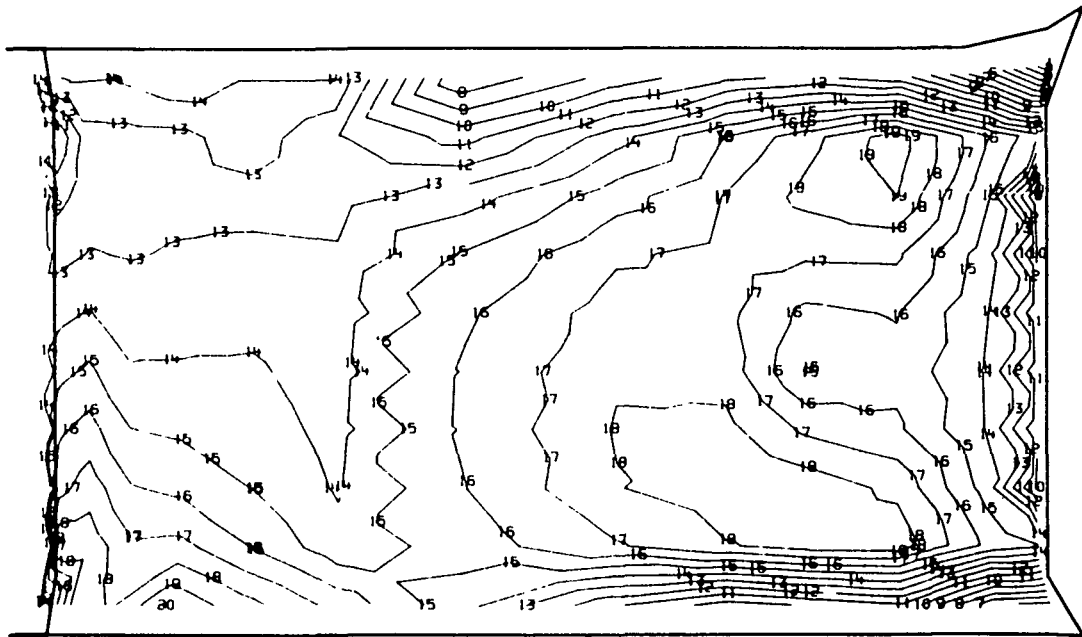
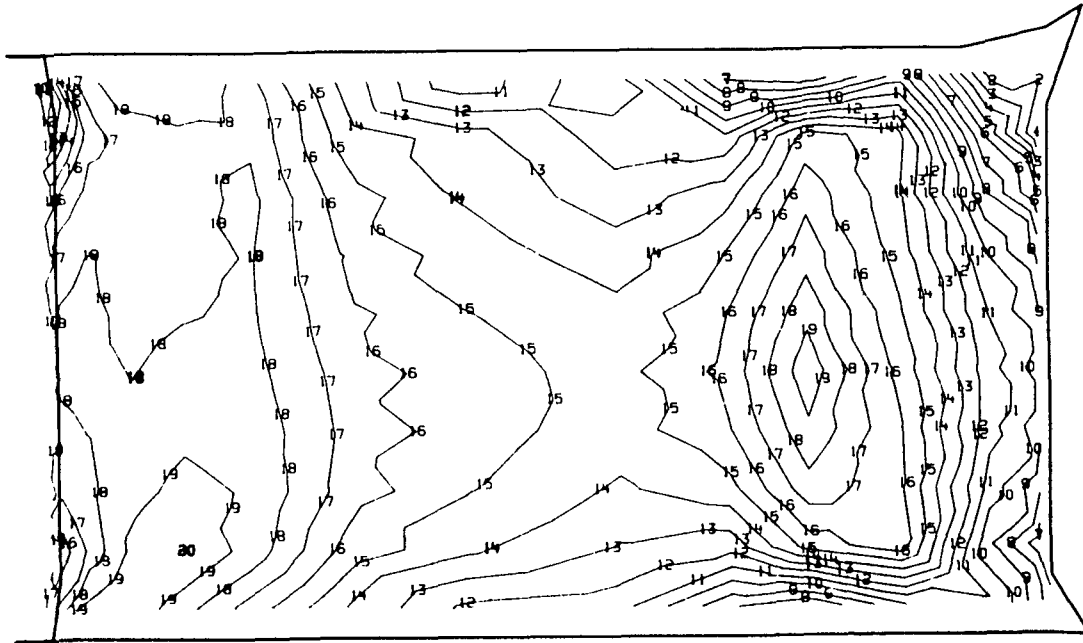

Fig. 3.4-15 Model 01, View 3, Airfoil Suction Side



1	-8.285731E C4	11	-1.417234E C4
2	-7.598881E C4	12	-7.303848E C3
3	-6.912031E C4	13	-4.353516E C2
4	-6.225182E C4	14	6.423145E C3
5	-5.538332E C4	15	1.330164E C4
6	-4.851482E C4	16	2.017014E C4
7	-4.164633E C4	17	2.703863E C4
8	-3.477783E C4	18	3.390713E C4
9	-2.790934E C4	19	4.077563E C4
10	-2.104084E C4	20	4.764414E C4

Fig. 3.4-16 Model 01, FPL Load, View 3, Major Principal Stress (psi)



1	-1.458182E C5	11	-6.313072E C4
2	-1.375494E C5	12	-5.486200E C4
3	-1.292807E C5	13	-4.659328E C4
4	-1.210119E C5	14	-3.832456E C4
5	-1.127432E C5	15	-3.005584E C4
6	-1.044744E C5	16	-2.178713E C4
7	-9.620569E C4	17	-1.251841E C4
8	-8.793694E C4	18	-5.249688E C3
9	-7.966819E C4	19	3.019031E 03
10	-7.139944E C4	20	1.128754E 04

Fig. 3.4-17 Model 01, FPL Load, View 3, Minor Principal Stress (psi)

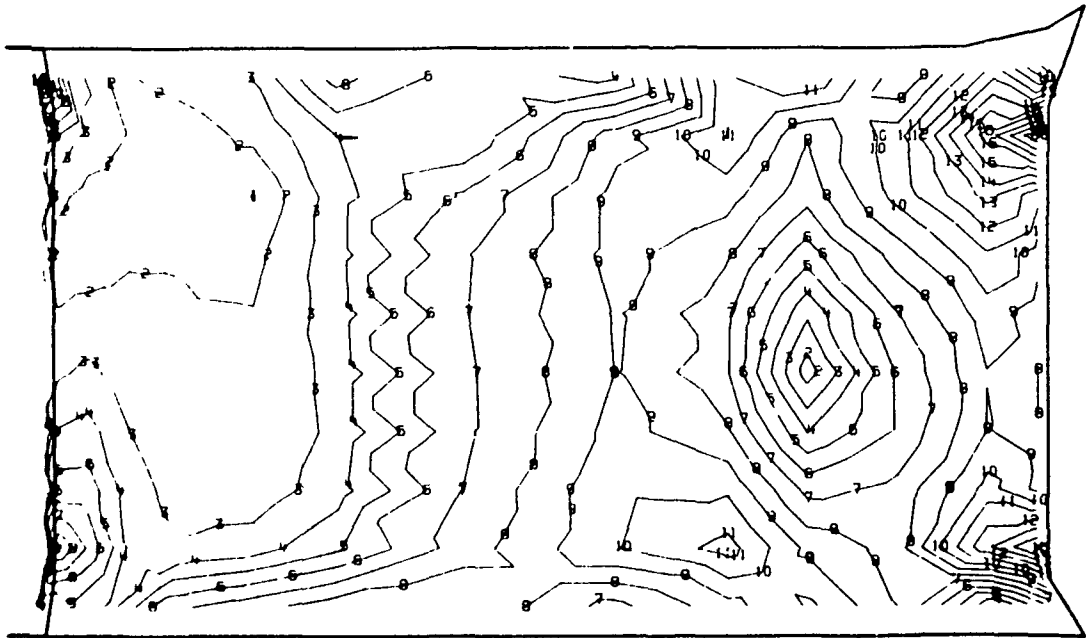

1	1.391761E 02	11	4.091050E 04
2	4.216309E 03	12	4.498764E 04
3	8.293441E 03	13	4.906477E 04
4	1.237057E 04	14	5.314190E 04
5	1.644771E 04	15	5.721904E 04
6	2.052484E 04	16	6.129617E 04
7	2.460197E 04	17	6.537330E 04
8	2.867911E 04	18	6.945038E 04
9	3.275624E 04	19	7.352750E 04
10	3.683337E 04	20	7.760475E 04

Fig. 3.4-18 Model 01, FPL Load, View 3, Maximum Principal Shear (psi)

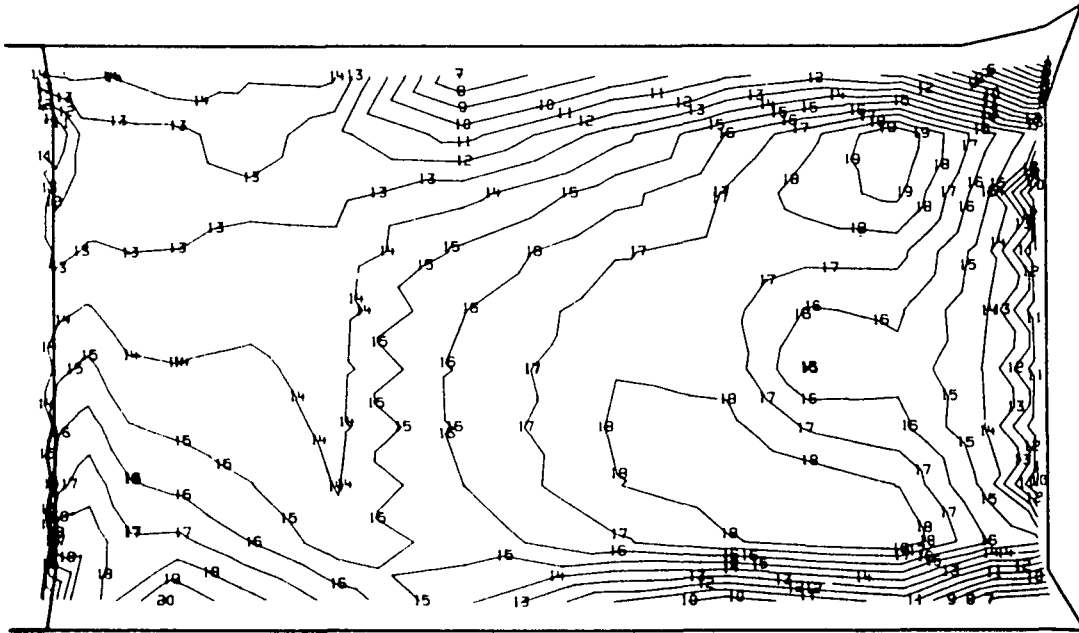

1	-9.476231E 04	11	-1.594481E 04
2	-8.688056E 04	12	-8.063063E 03
3	-7.899881E 04	13	-1.813125E 02
4	-7.111706E 04	14	7.700438E 03
5	-6.323531E 04	15	1.558219E 04
6	-5.535356E 04	16	2.346394E 04
7	-4.747181E 04	17	3.134569E 04
8	-3.959006E 04	18	3.922744E 04
9	-3.170831E 04	19	4.710919E 04
10	-2.382656E 04	20	5.499102E 04

Fig. 3.4-19 Model 01, View 3, 115% Load, Major Principal Stress (psi)

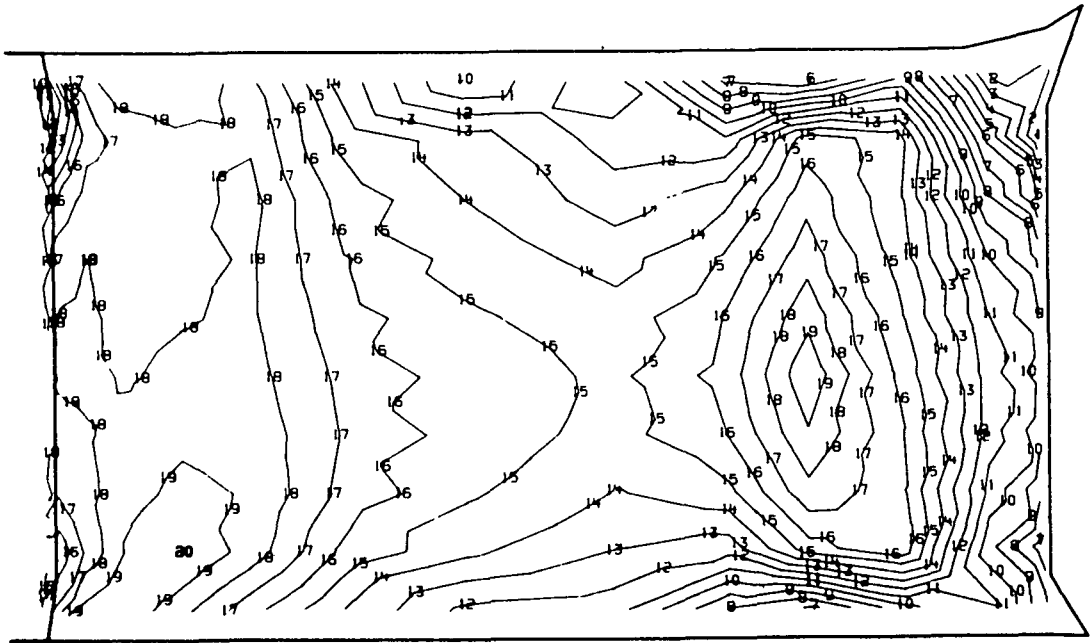

1	-1.660840E 05	11	-7.182713E 04
2	-1.566583E 05	12	-6.240146E 04
3	-1.472326E 05	13	-5.297579E 04
4	-1.378069E 05	14	-4.355012E 04
5	-1.283813E 05	15	-3.412445E 04
6	-1.189556E 05	16	-2.469879E 04
7	-1.095299E 05	17	-1.527312E 04
8	-1.001042E 05	18	-5.847449E 03
9	-9.067850E 04	19	3.576219E 03
10	-8.125281E 04	20	1.300378E 04

Fig. 3.4-20 Model 01, View 3, 115% Load, Minor Principal Stress (psi)

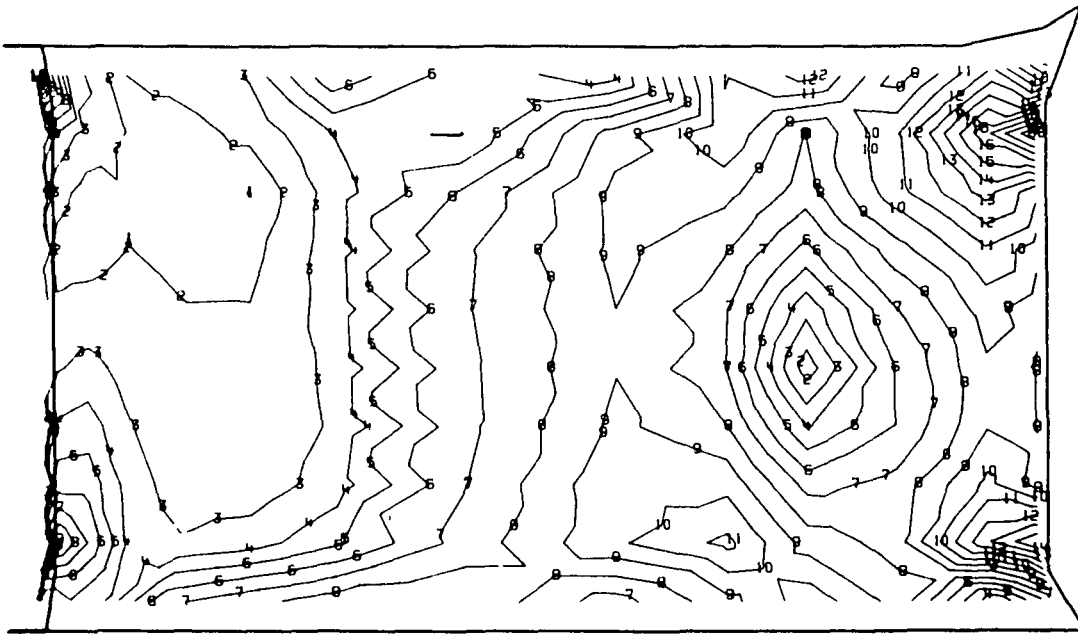

1	2.688811E 02	11	4.713427E 04
2	4.955418E 03	12	5.182081E 04
3	9.641957E 03	13	5.650735E 04
4	1.432850E 04	14	6.119389E 04
5	1.901504E 04	15	6.588038E 04
6	2.370157E 04	16	7.056688E 04
7	2.838811E 04	17	7.525338E 04
8	3.307465E 04	18	7.993988E 04
9	3.776119E 04	19	8.462638E 04
10	4.244773E 04	20	8.931319E 04

Fig. 3.4-21 Model 01, View 3, 115% Load, Shear Maximum Stress (psi)

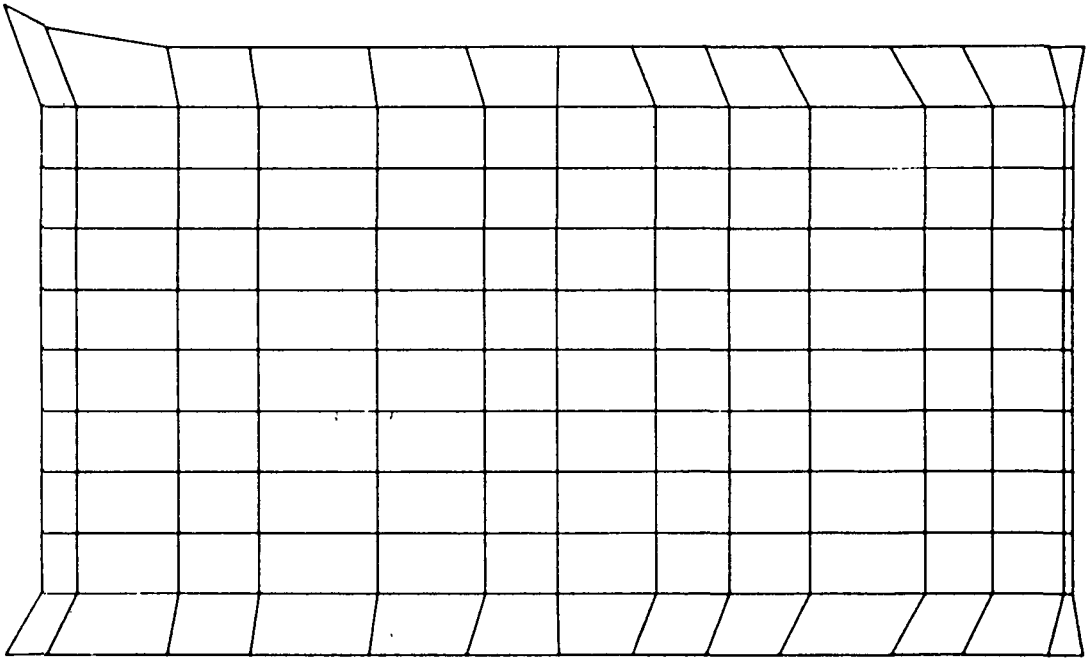
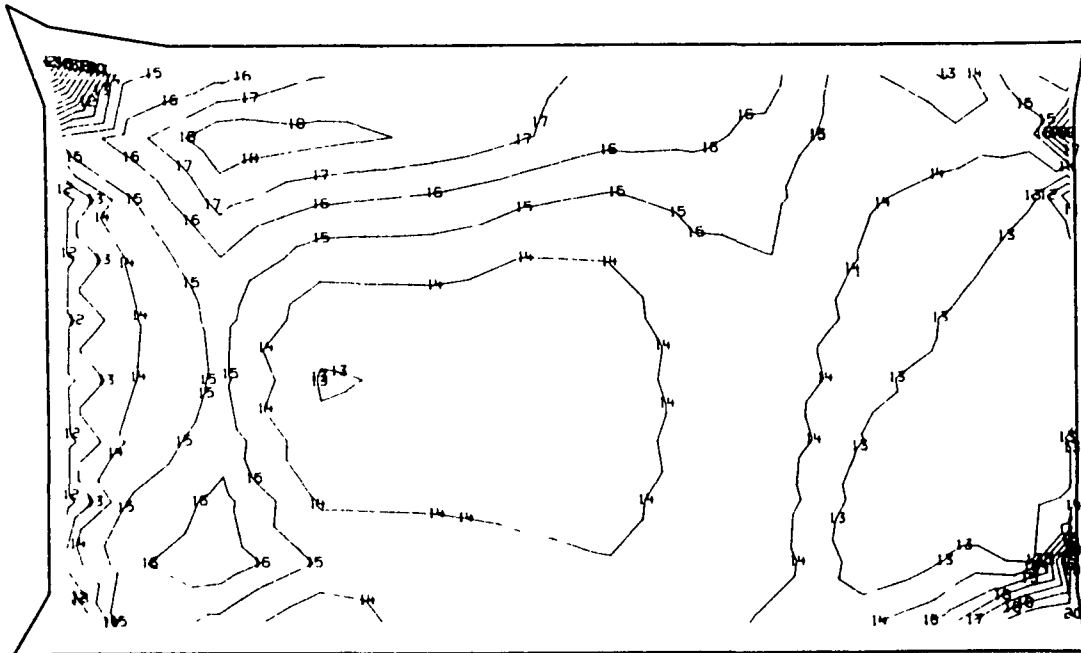
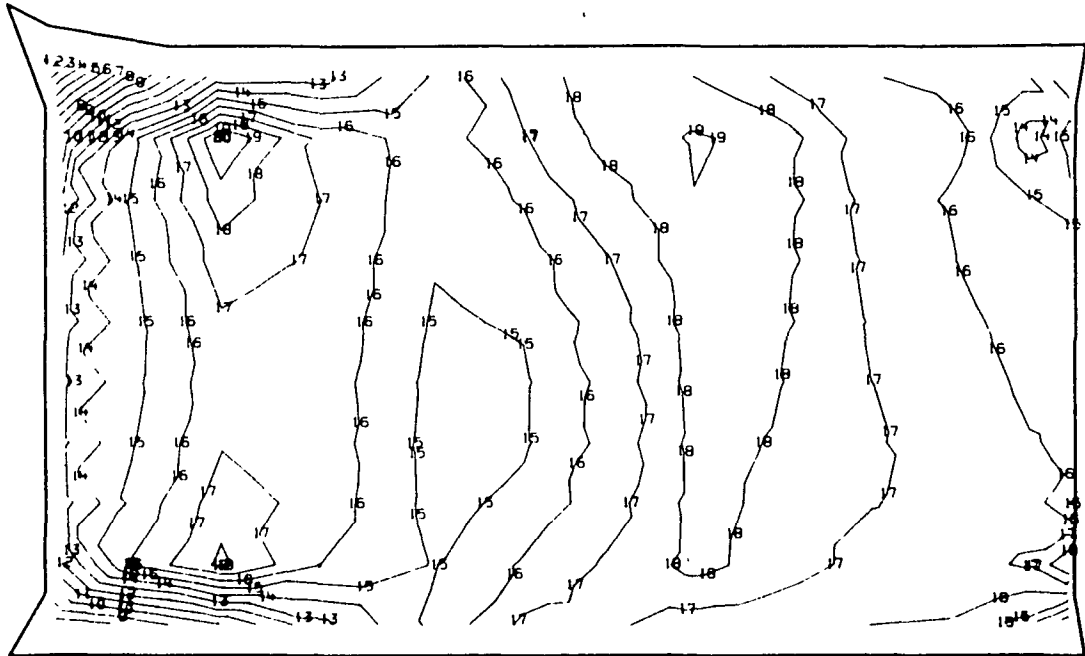

Fig. 3.4-22 Model 01, View 4, Airfoil Pressure Side



1	-1.146473E C5	11	-1.610123E C4
2	-1.047927E C5	12	-6.246629E C3
3	-9.493806E C4	13	3.607969E C3
4	-8.508344E C4	14	1.346257E C4
5	-7.522881E C4	15	2.321716E C4
6	-6.537421E C4	16	3.317176E C4
7	-5.551962E C4	17	4.302636E C4
8	-4.566502E C4	18	5.288096E C4
9	-3.581042E C4	19	6.273555E C4
10	-2.595582E C4	20	7.259006E C4

Fig. 3.4-23 Model 01, FPL Load, View 4, Major Principal Stress (psi)



1	-2.213956E C5	11	-8.657938E C4
2	-2.079140E C5	12	-7.309775E C4
3	-1.944324E C5	13	-5.561618E C4
4	-1.809508E C5	14	-4.613461E C4
5	-1.674691E C5	15	-2.265304E C4
6	-1.539875E C5	16	-1.917147E C4
7	-1.405059E C5	17	-5.689898E C3
8	-1.270243E C5	18	7.791672E C3
9	-1.135426E C5	19	2.127324E C4
10	-1.000610E C5	20	3.475425E C4

Fig. 3.4-24 Model 01, FPL Load, View 4, Minor Principal Stress (psi)

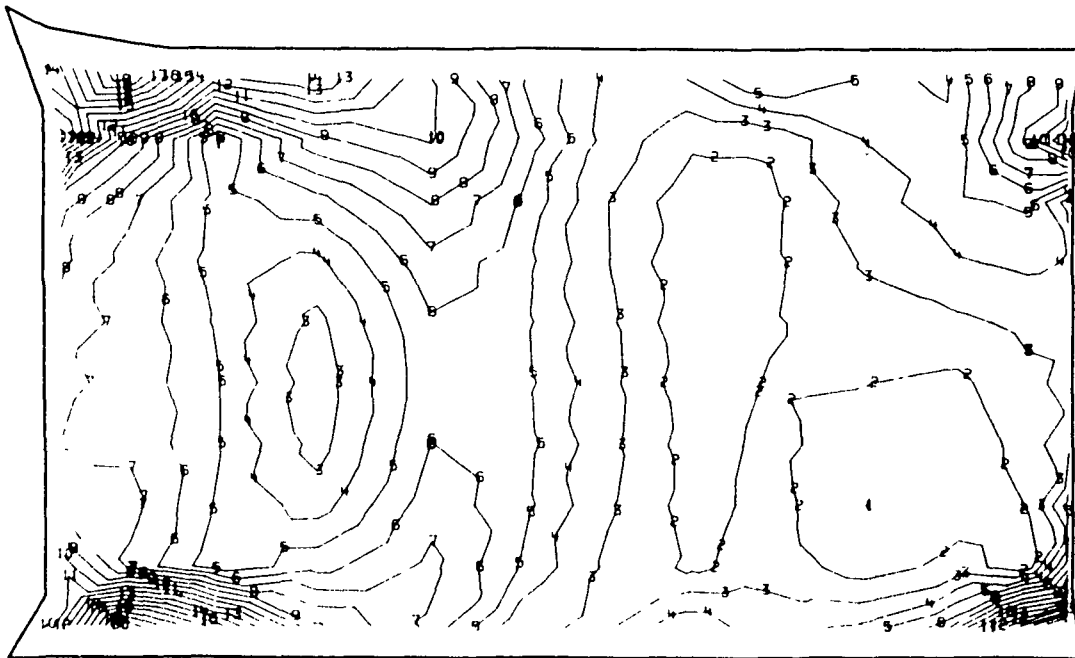

1	1.577649E C2	11	4.209132E C4
2	5.629016E C3	12	4.614269E C4
3	9.680383E C3	13	5.019405E C4
4	1.373175E C4	14	5.424542E C4
5	1.778212E C4	15	5.829679E C4
6	2.183448E C4	16	6.234816E C4
7	2.588585E C4	17	6.639950E C4
8	2.993722E C4	18	7.045081E C4
9	3.398859E C4	19	7.450213E C4
10	3.803995E C4	20	7.855369E C4

Fig. 3.4-25 Model 01, FPL Load, View 4, Maximum Principal Shear (psi)

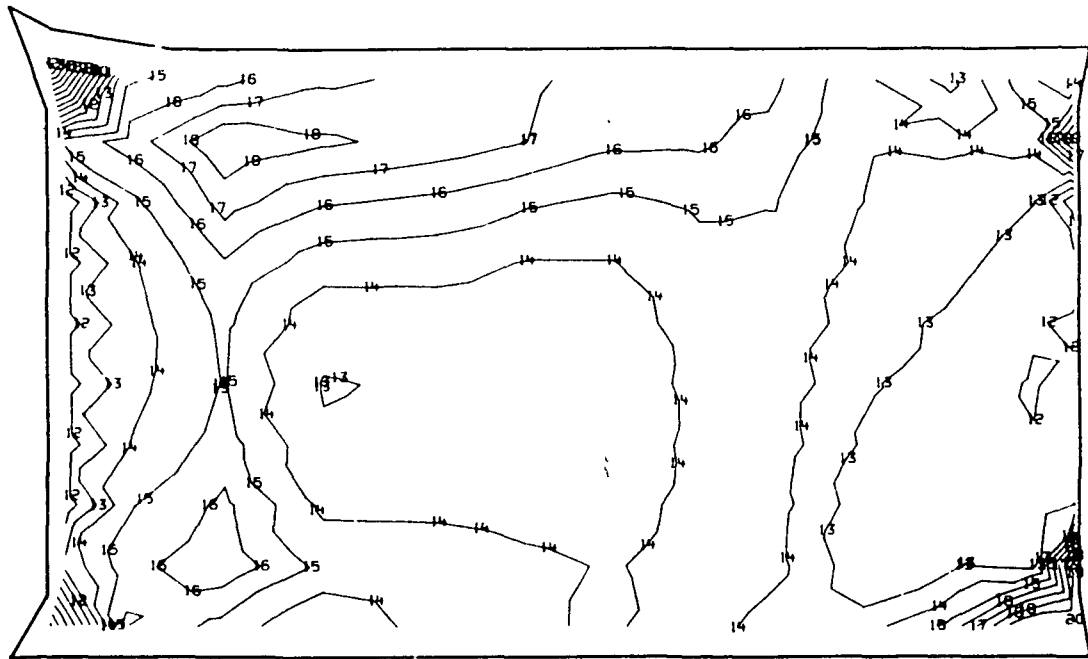

1	-1.293717E 05	11	-1.616757E 04
2	-1.180513E 05	12	-4.847180E 03
3	-1.067308E 05	13	6.473207E 03
4	-9.541038E 04	14	1.779359E 04
5	-8.408994E 04	15	2.911358E 04
6	-7.276950E 04	16	4.043437E 04
7	-6.144911E 04	17	5.175475E 04
8	-5.012873E 04	18	6.307514E 04
9	-3.880834E 04	19	7.439550E 04
10	-2.748795E 04	20	8.571569E 04

Fig. 3.4-26 Model 01, View 4, 115% Lod, Major Principal Straess (psi)

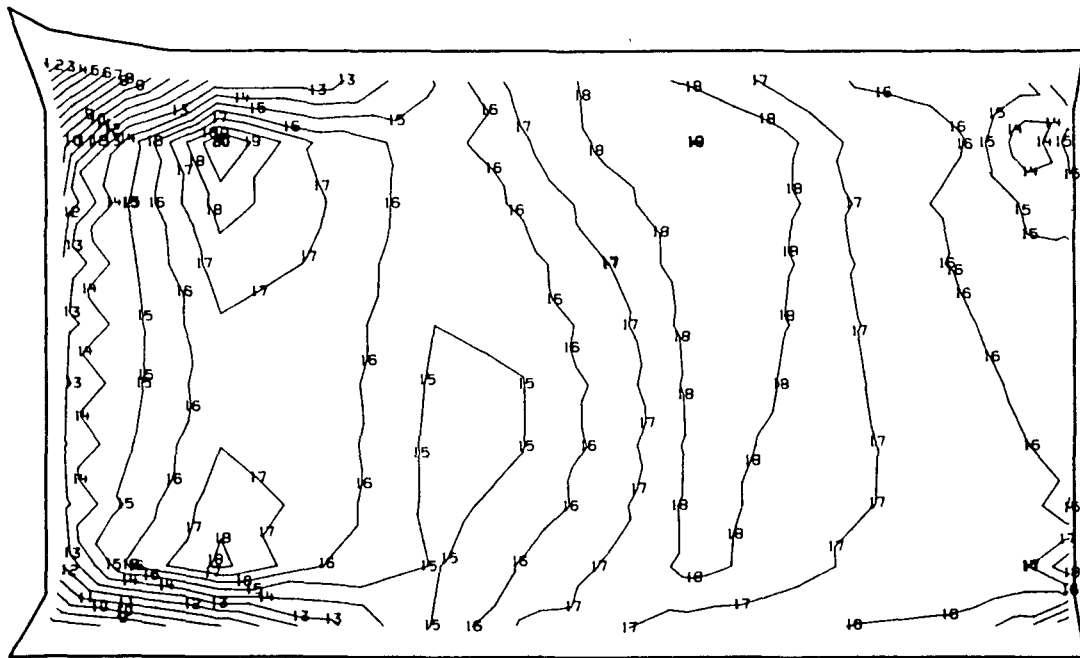

1	-2.543069E 05	11	-9.884750E 04
2	-2.387609E 05	12	-8.330156E 04
3	-2.232150E 05	13	-6.775563E 04
4	-2.076691E 05	14	-5.220971E 04
5	-1.921231E 05	15	-3.666380E 04
6	-1.765772E 05	16	-2.111788E 04
7	-1.610313E 05	17	-5.571969E 03
8	-1.454853E 05	18	9.973945E 03
9	-1.299394E 05	19	2.551586E 04
10	-1.143934E 05	20	4.106561E 04

Fig. 3.4-27 Model 01, View 4, 115% Load, Minor Principal Stress (psi)

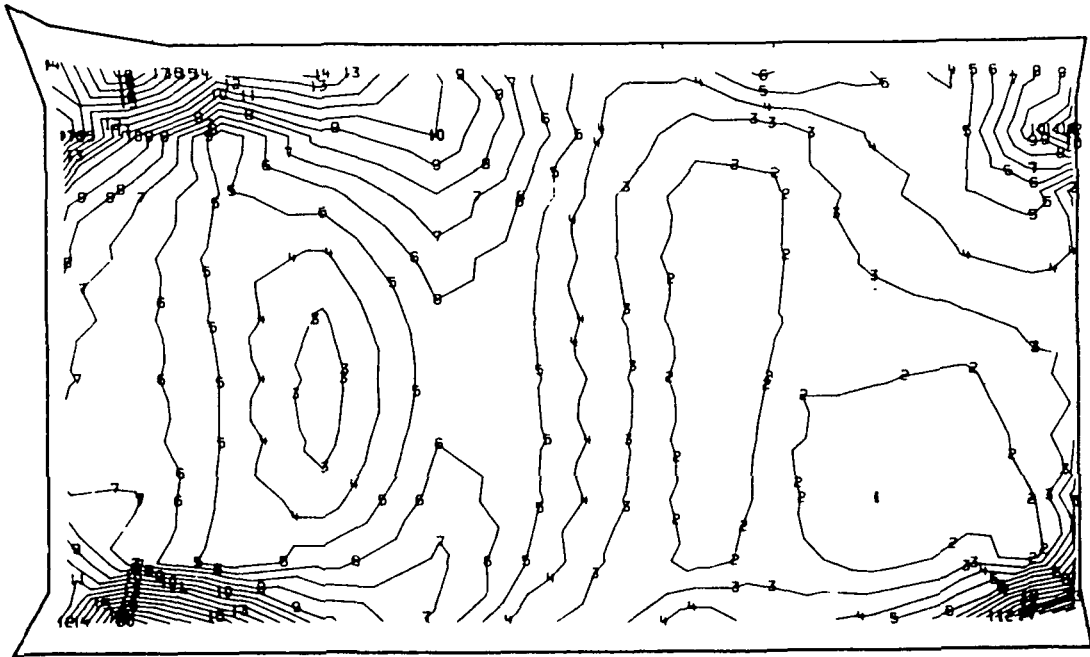

1	1.688271E 03	11	4.900542E 04
2	6.419984E 03	12	5.373713E 04
3	1.115170E 04	13	5.846885E 04
4	1.588341E 04	14	6.320056E 04
5	2.061513E 04	15	6.793225E 04
6	2.534684E 04	16	7.266394E 04
7	3.007856E 04	17	7.739563E 04
8	3.481027E 04	18	8.212731E 04
9	3.954199E 04	19	8.685900E 04
10	4.427370E 04	20	9.159094E 04

Fig. 3.4-28 Model 01, View 4, 115% Load, Shear Maximum Stress (psi)

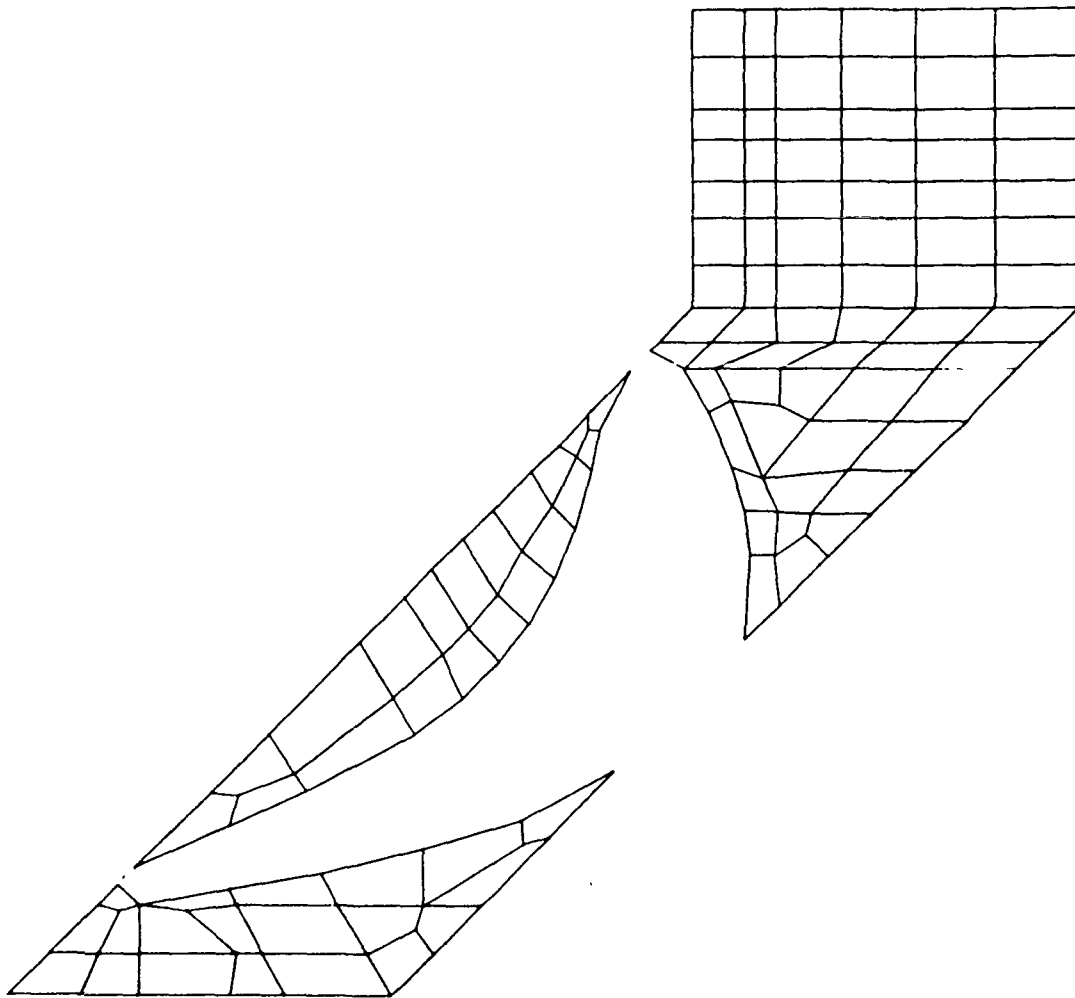
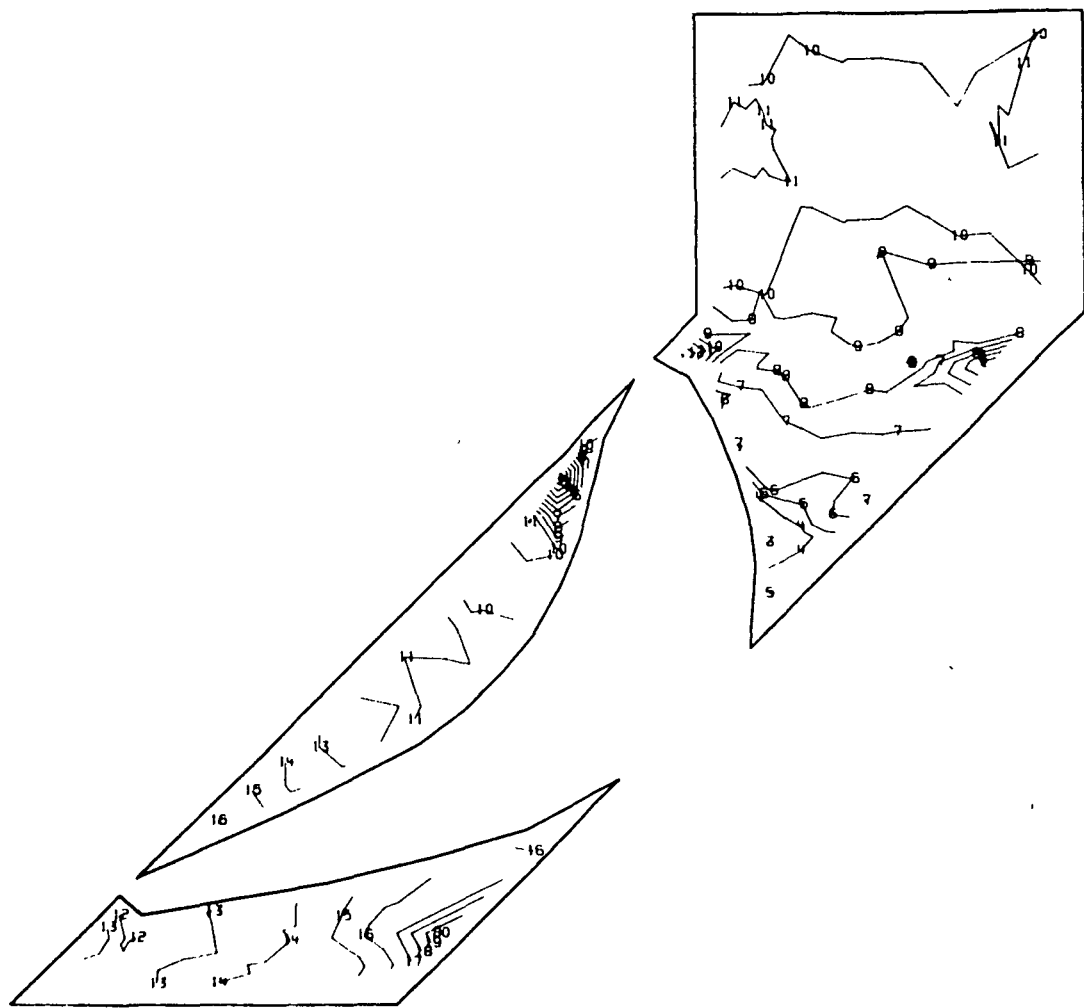
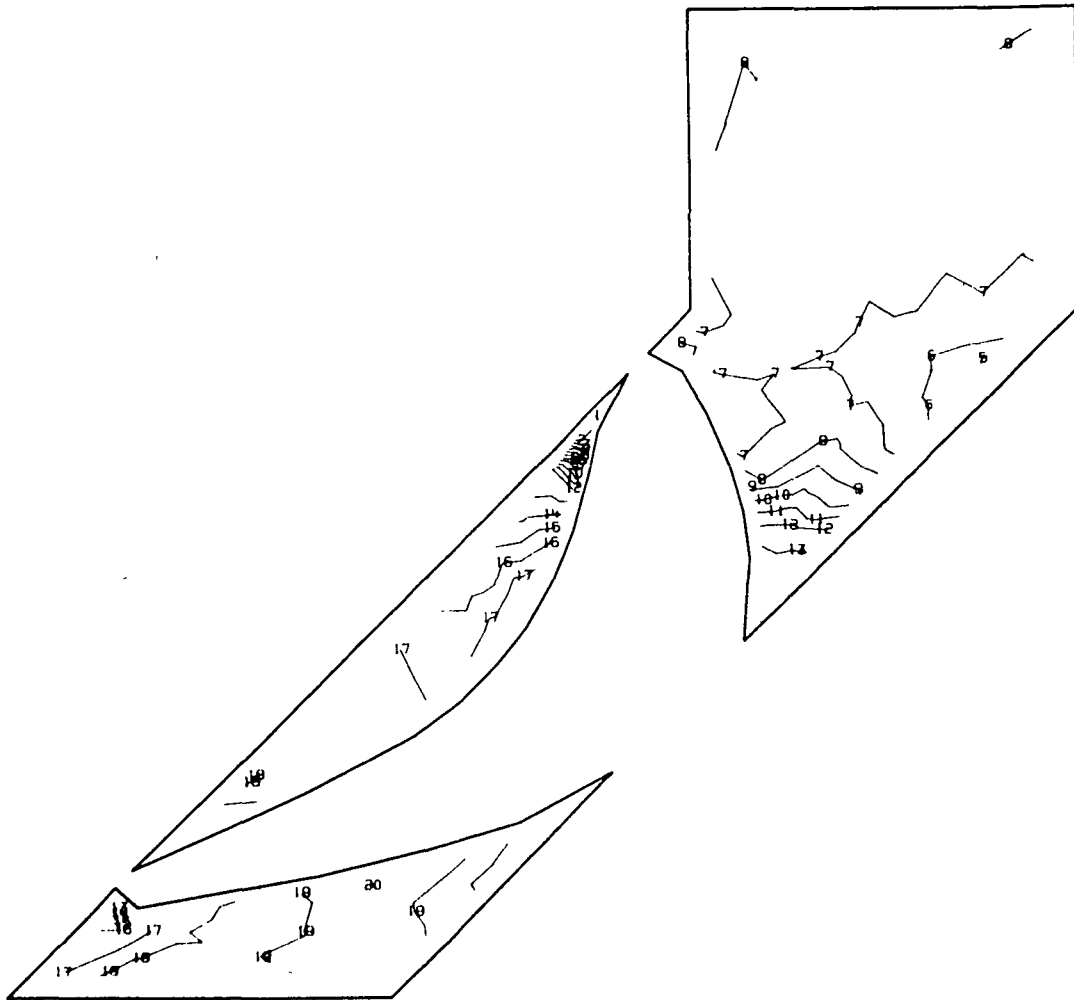

Fig. 3.4-29 Model 01, View 5, Hub Foil Side



1	-1.124581E C5	11	1.163729E 04
2	-1.000485E C5	12	2.404681E C4
3	-8.763894E C4	13	2.645634E C4
4	-7.522938E C4	14	4.886586E C4
5	-6.231985E 04	15	6.127538E C4
6	-5.041033E C4	16	7.368489E C4
7	-3.800080E C4	17	8.609438E C4
8	-2.559128E 04	18	9.850389E C4
9	-1.318176E C4	19	1.109134E C5
10	-7.722344E 02	20	1.233229E C5

Fig. 3.4-30 Model 01, FPL Load, View 5, Major Principal Stress (psi)



1	-3.535342E C5	11	-1.578198E C5
2	-3.339628E C5	12	-1.382484E C5
3	-3.143913E C5	13	-1.186769E C5
4	-2.948199E C5	14	-9.910550E C4
5	-2.752484E C5	15	-7.952406E C4
6	-2.556770E C5	16	-5.996265E C4
7	-2.361056E C5	17	-4.035123E C4
8	-2.165341E C5	18	-2.081982E C4
9	-1.969627E C5	19	-1.248406E C3
10	-1.773913E C5	20	1.832272E C4

Fig. 3.4-31 Model 01, FPL Load, View 5, Minor Principal Stress (psi)

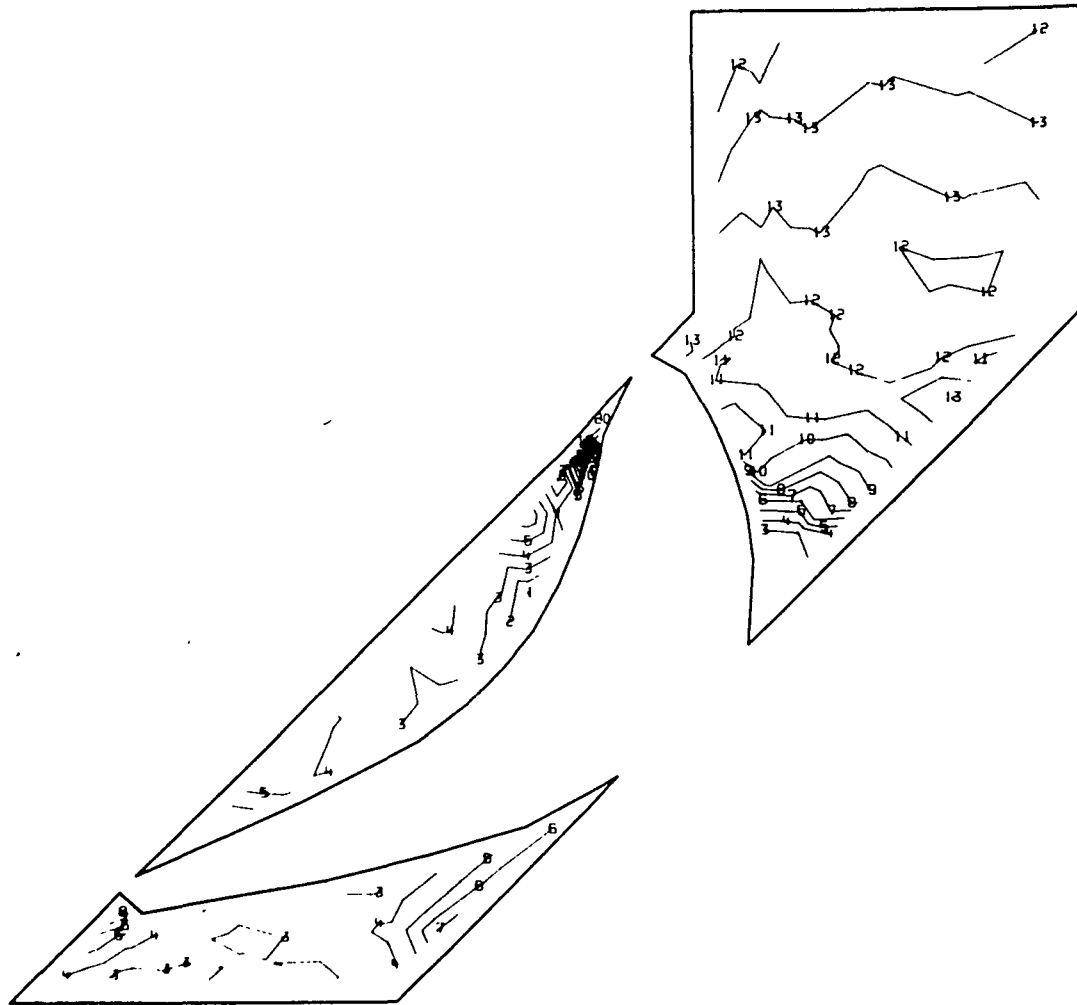

1	6.472414E C3	11	9.565619E 04
2	1.579080E C4	12	1.089746E C5
3	2.510919E C4	13	1.182929E 05
4	3.442757E C4	14	1.276113E C5
5	4.374596E C4	15	1.369297E C5
6	5.306435E 04	16	1.462481E C5
7	6.238273E C4	17	1.555664E C5
8	7.170106E C4	18	1.648848E C5
9	8.101944E C4	19	1.742032E C5
10	9.033781E C4	20	1.835218E C5

Fig. 3.4-32 Model 01, FPL Load, View 5, Maximum Principal Shear (psi)

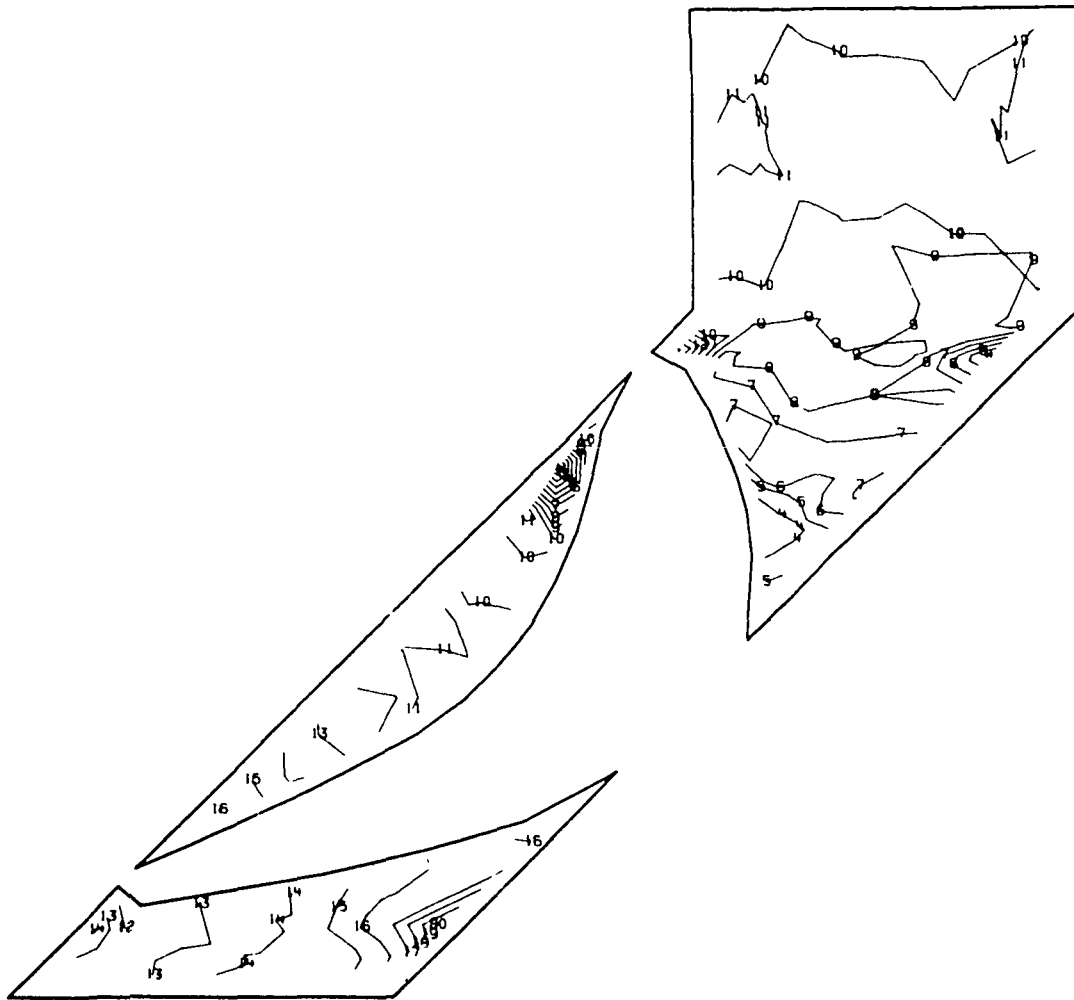

1	-1.313120E 05	11	1.288795E 04
2	-1.168920E 05	12	2.730795E 04
3	-1.024720E 05	13	4.172794E 04
4	-8.805200E 04	14	5.614793E 04
5	-7.363200E 04	15	7.056788E 04
6	-5.921201E 04	16	8.498781E 04
7	-4.479202E 04	17	9.940775E 04
8	-3.037202E 04	18	1.138277E 05
9	-1.595203E 04	19	1.282476E 05
10	-1.532039E 03	20	1.426679E 05

Fig. 3.4-33 Model 01, View 5, 115% Load, Major Principal Stress (psi)

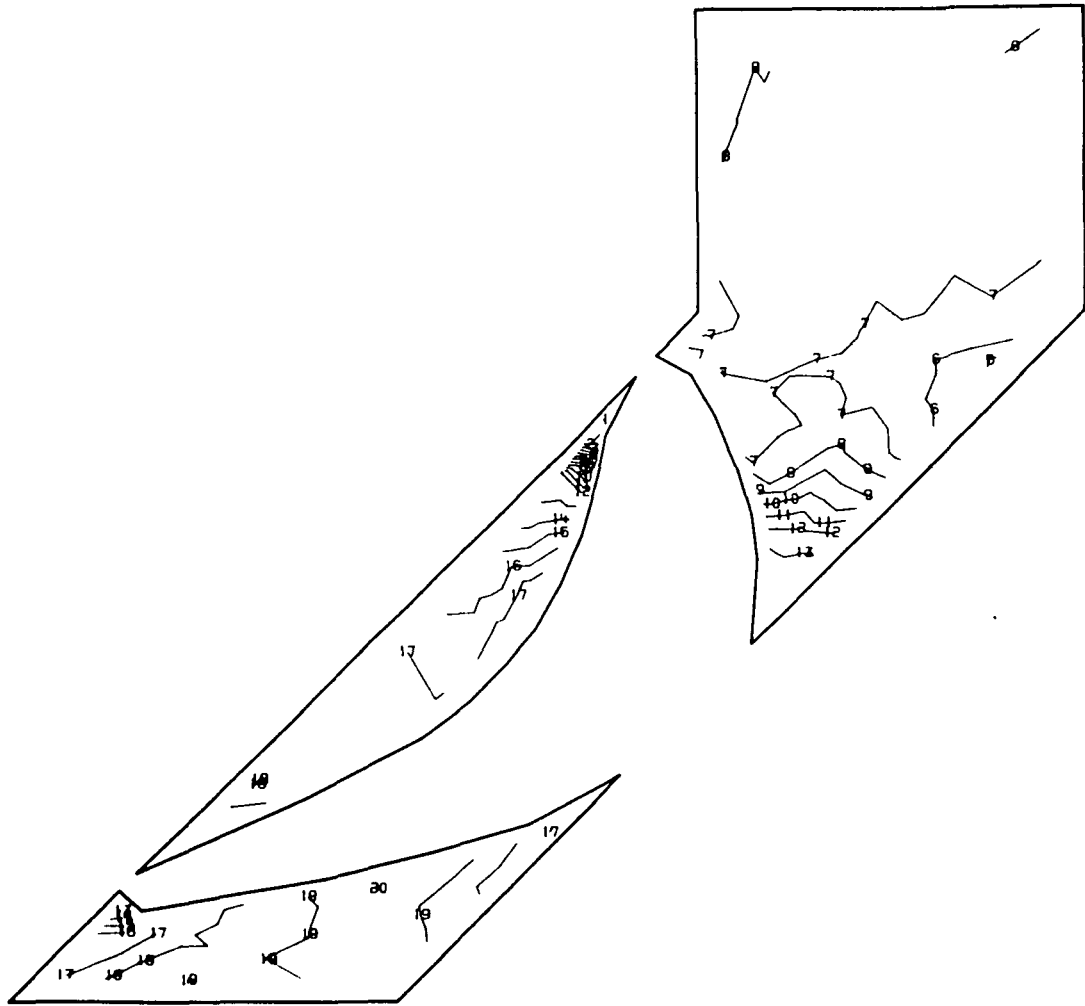

1	-4.093720E 05	11	-1.830864E 05
2	-3.867434E 05	12	-1.604578E 05
3	-3.641149E 05	13	-1.378293E 05
4	-3.414863E 05	14	-1.152007E 05
5	-3.188578E 05	15	-9.257213E 04
6	-2.962292E 05	16	-6.994356E 04
7	-2.736006E 05	17	-4.731502E 04
8	-2.509721E 05	18	-2.468648E 04
9	-2.283435E 05	19	-2.057934E 03
10	-2.057149E 05	20	2.057039E 04

Fig. 3.4-34 Model 01, View 5, 115% Load, Minor Principal Stress (psi)

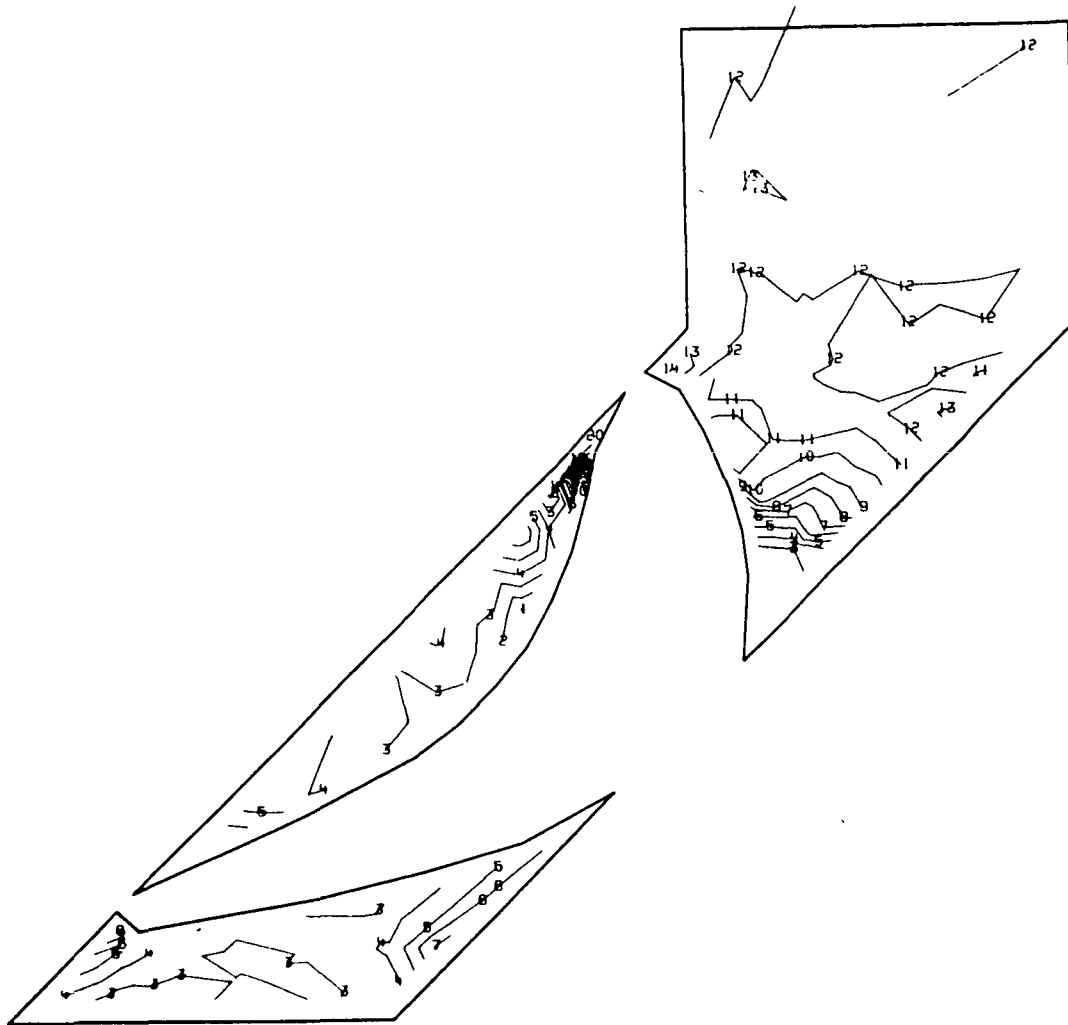

1	8.659859E 03	11	1.172211E 05
2	1.951598E 04	12	1.280772E 05
3	3.037211E 04	13	1.389333E 05
4	4.122823E 04	14	1.497894E 05
5	5.208436E 04	15	1.606456E 05
6	6.294048E 04	16	1.715017E 05
7	7.379656E 04	17	1.823578E 05
8	8.465269E 04	18	1.932139E 05
9	9.550881E 04	19	2.040701E 05
10	1.063649E 05	20	2.149263E 05

Fig. 3.4-35 Model 01, View 5, 115% Load, Shear Maximum Stress (psi)

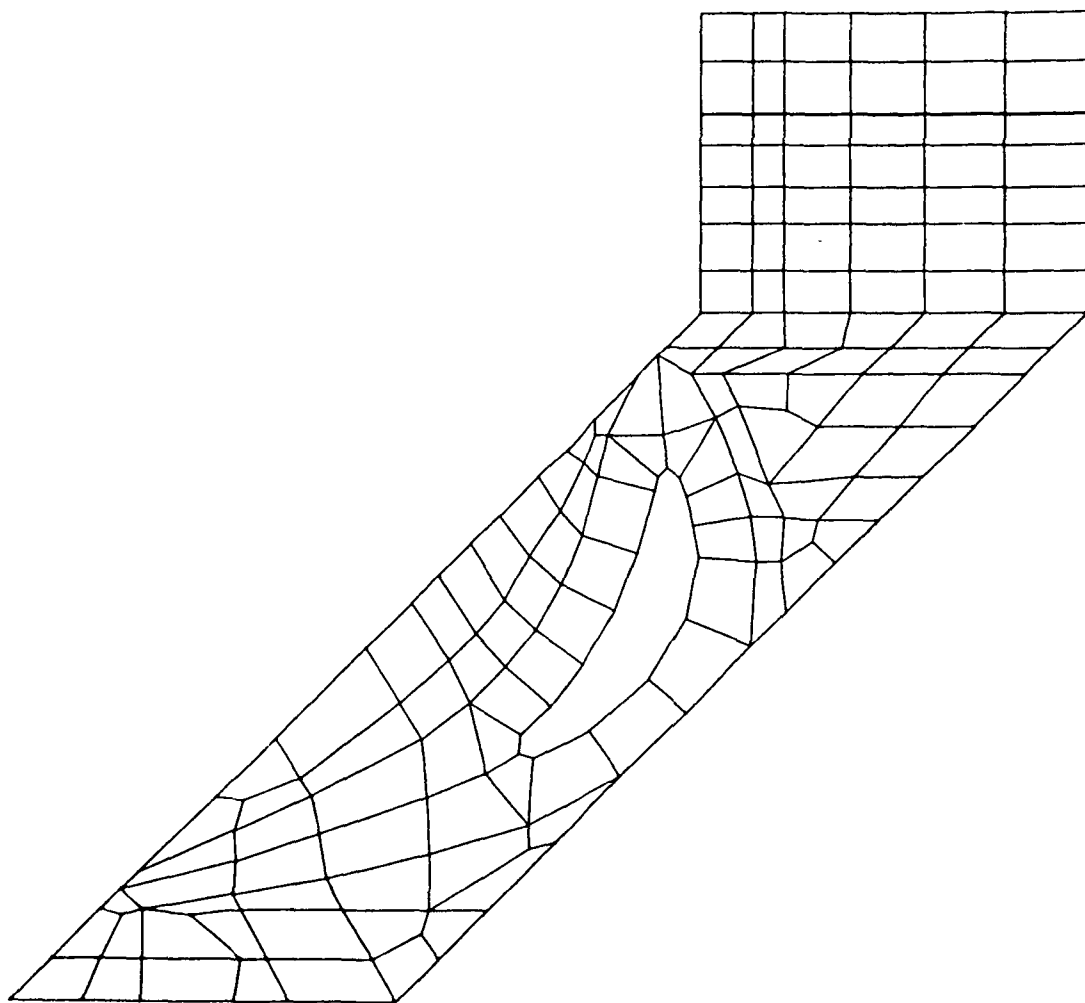
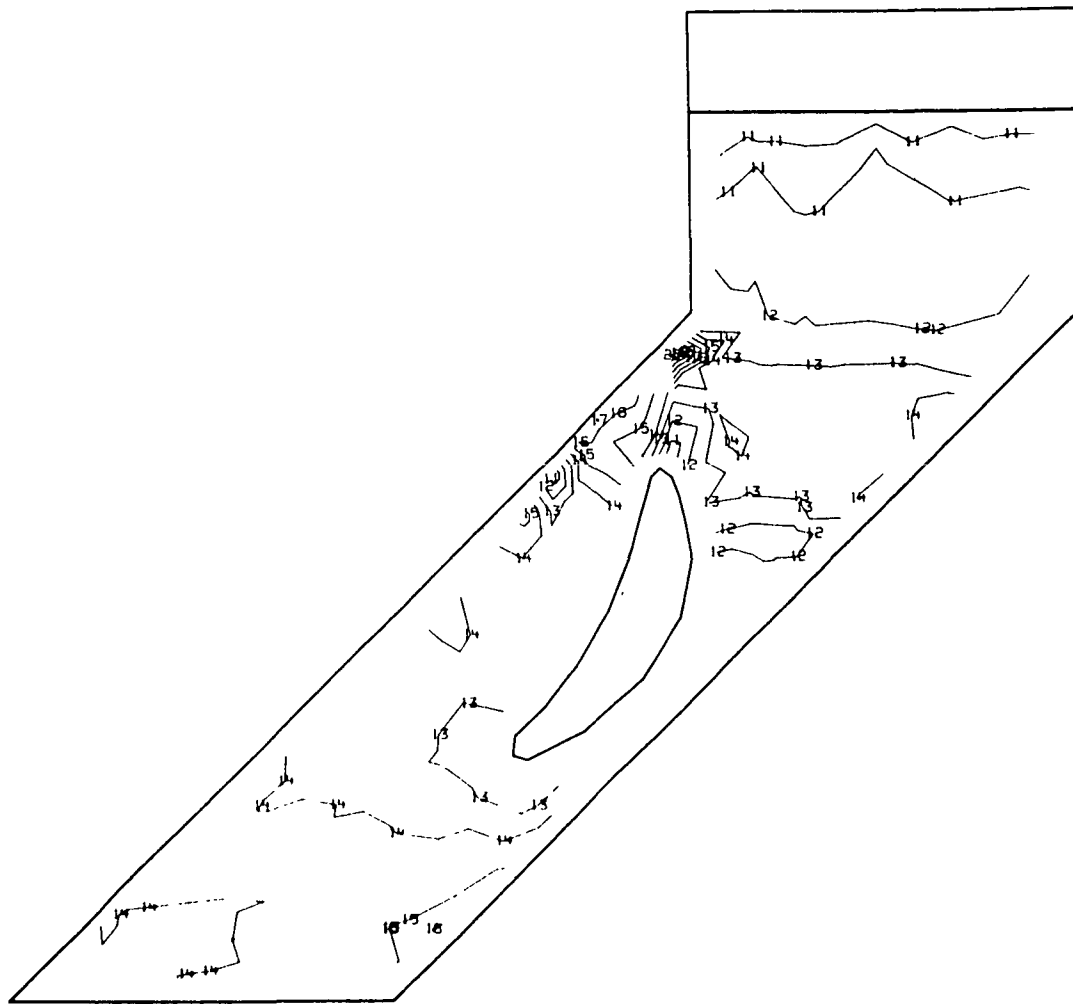
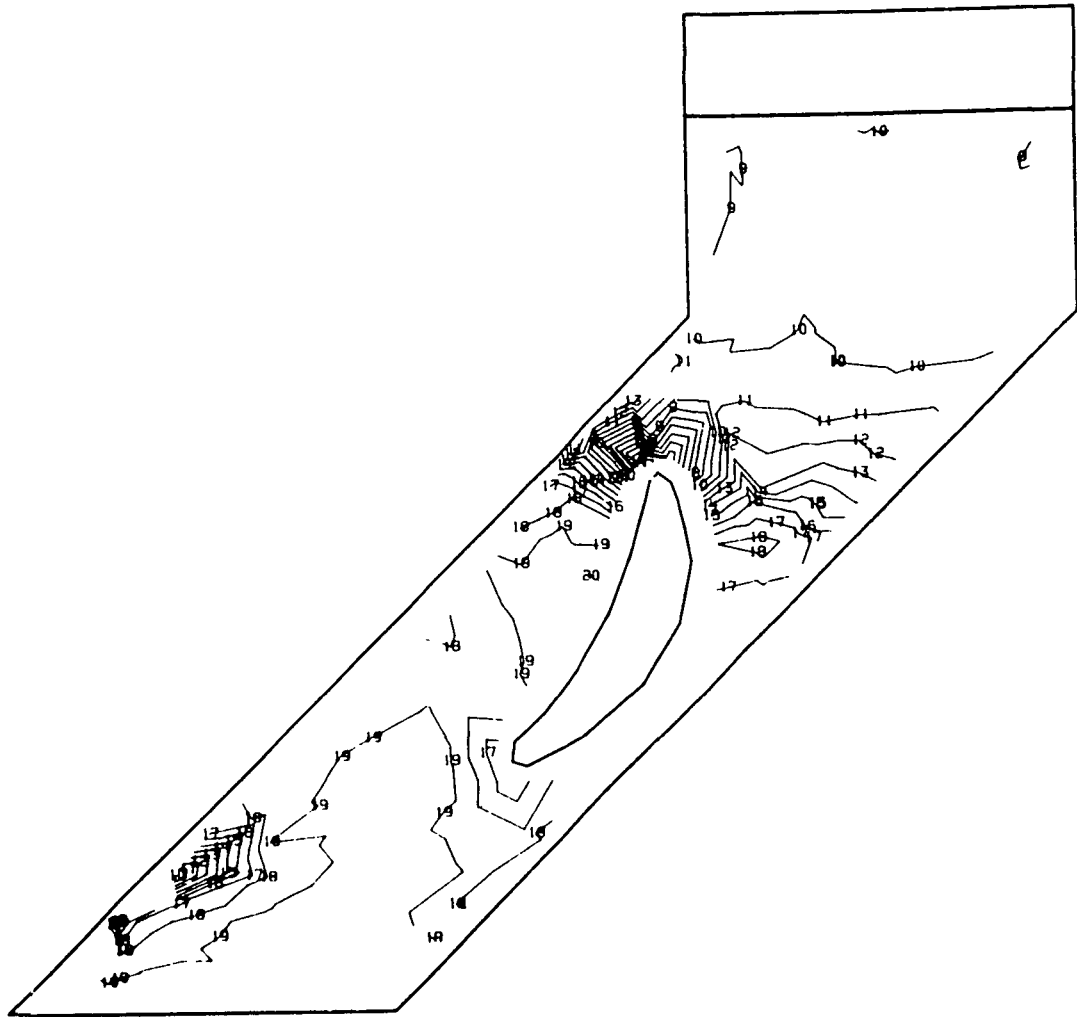

Fig. 3.4-36 Model 01, View 6, Hub Inner



1	-3.247573E C5	11	-3.824601E C4
2	-2.961061E C5	12	-9.594898E C3
3	-2.674550E C5	13	1.905621E 04
4	-2.388039E C5	14	4.770733E C4
5	-2.101528E C5	15	7.635844E C4
6	-1.815016E C5	16	1.050095E C5
7	-1.528505E C5	17	1.336606E C5
8	-1.241994E C5	18	1.623116E C5
9	-9.554825E C4	19	1.905627E C5
10	-6.689713E C4	20	2.196139E 05

Fig. 3.4-37 Model 01, FPL Load, View 6, Major Principal Stress (psi)



1	-4.380581E C5	11	-2.064231E C5
2	-4.148946E C5	12	-1.822596E C5
3	-3.917211E C5	13	-1.600961E 05
4	-3.685676E C5	14	-1.369326E C5
5	-3.454041E C5	15	-1.137691E C5
6	-3.222406E C5	16	-9.060563E 04
7	-2.990771E C5	17	-6.744213E 04
8	-2.759136E C5	18	-4.427863E 04
9	-2.527501E C5	19	-2.111513E 04
10	-2.295866E C5	20	2.048457E 03

Fig. 3.4-38 Model 01, FPL Load, View 6, Minor Principal Stress (psi)

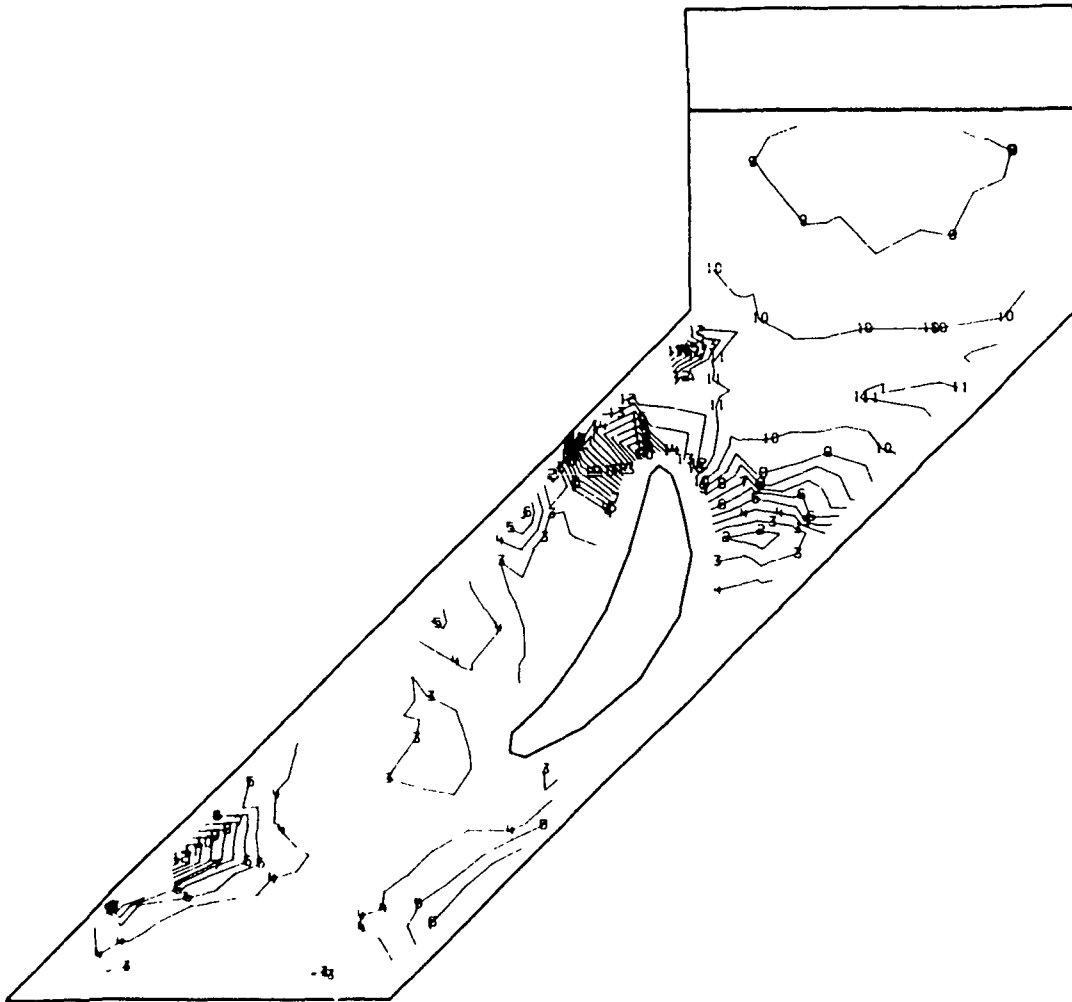

1	0.0	11	1.270752E C5
2	1.270753E C4	12	1.397827E 05
3	2.541506E C4	13	1.524902E C5
4	3.812259E C4	14	1.651977E C5
5	5.083013E C4	15	1.779052E C5
6	6.353766E C4	16	1.906127E C5
7	7.624519E C4	17	2.033202E C5
8	8.895269E C4	18	2.160277E C5
9	1.016602E C5	19	2.287352E C5
10	1.143677E C5	20	2.414431E C5

Fig. 3.4-39 Model 01, FPL Load, View 6, Maximum Principal Shear (psi)

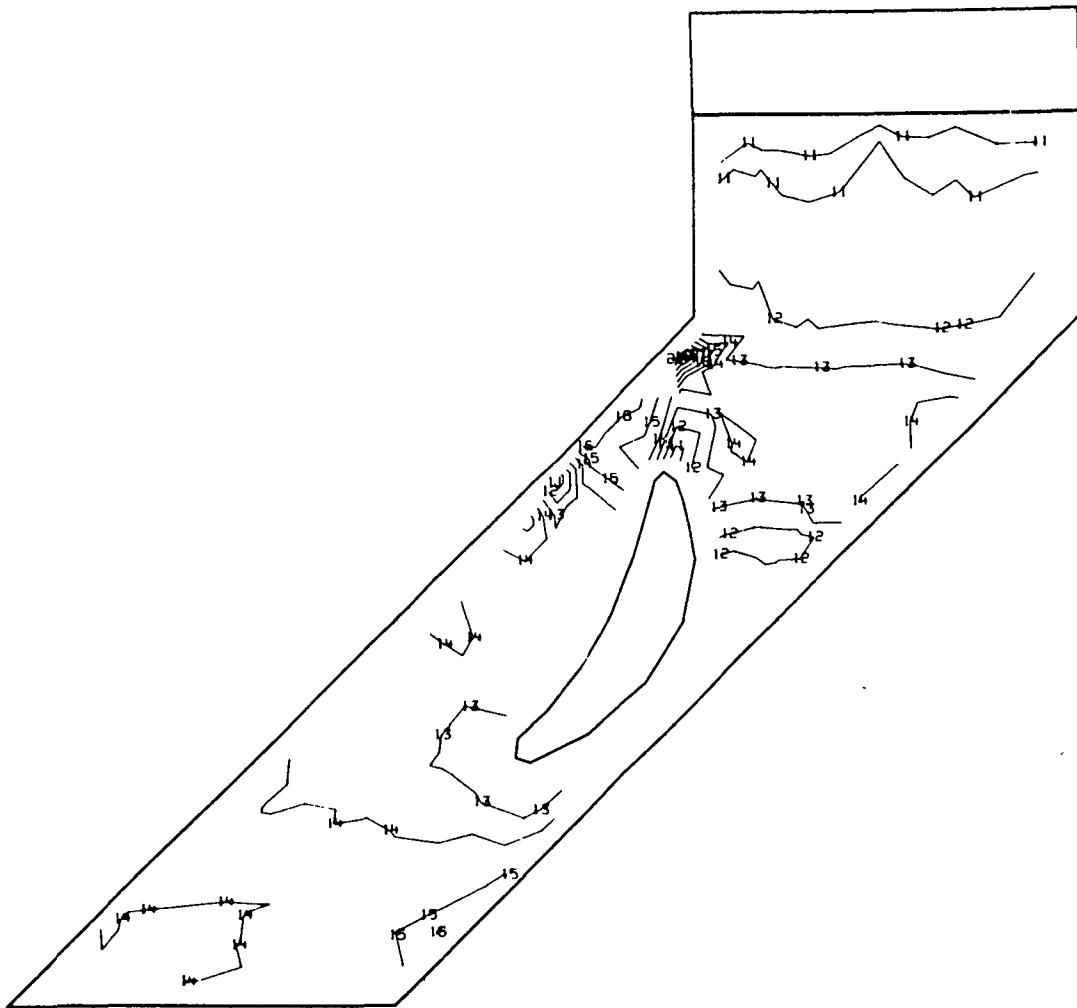

1	-3.794641E 05	11	-4.433250E 04
2	-3.459510E 05	12	-1.081980E 04
3	-3.124379E 05	13	2.269330E 04
4	-2.789248E 05	14	5.620641E 04
5	-2.454116E 05	15	8.971950E 04
6	-2.118985E 05	16	1.232326E 05
7	-1.783854E 05	17	1.567456E 05
8	-1.448723E 05	18	1.902587E 05
9	-1.113591E 05	19	2.237718E 05
10	-7.784600E 04	20	2.572849E 05

Fig. 3.4-40 Model 01, View 6, 115% Load, Major Principal Stress (psi)

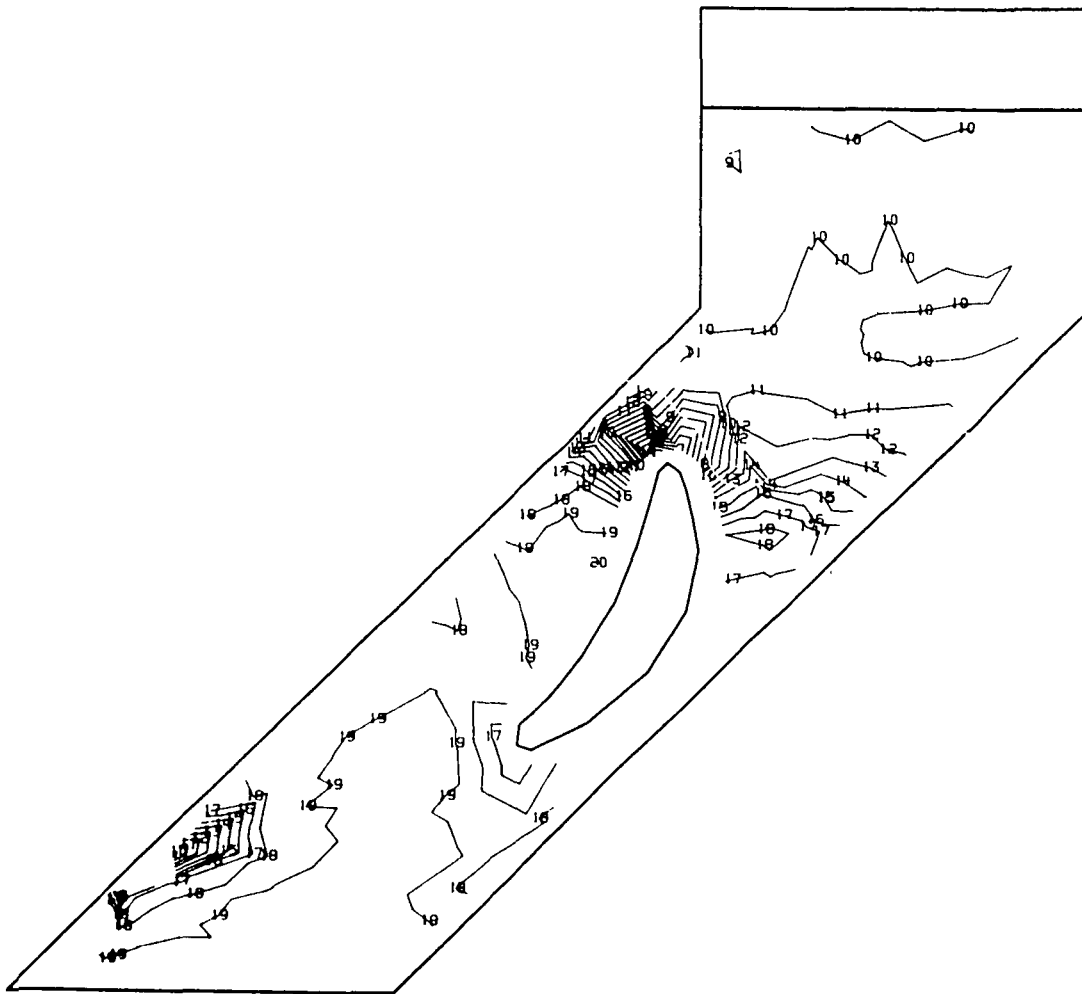

1	-5.151428E 05	11	-2.427153E 05
2	-4.879000E 05	12	-2.154725E 05
3	-4.606573E 05	13	-1.882258E 05
4	-4.334145E 05	14	-1.609870E 05
5	-4.061718E 05	15	-1.337443E 05
6	-3.789290E 05	16	-1.065015E 05
7	-3.516863E 05	17	-7.925875E 04
8	-3.244435E 05	18	-5.201602E 04
9	-2.972008E 05	19	-2.477330E 04
10	-2.699580E 05	20	2.465078E 03

Fig. 3.4-41 Model 01, View 6, 115% Load, Minor Principal Stress (psi)

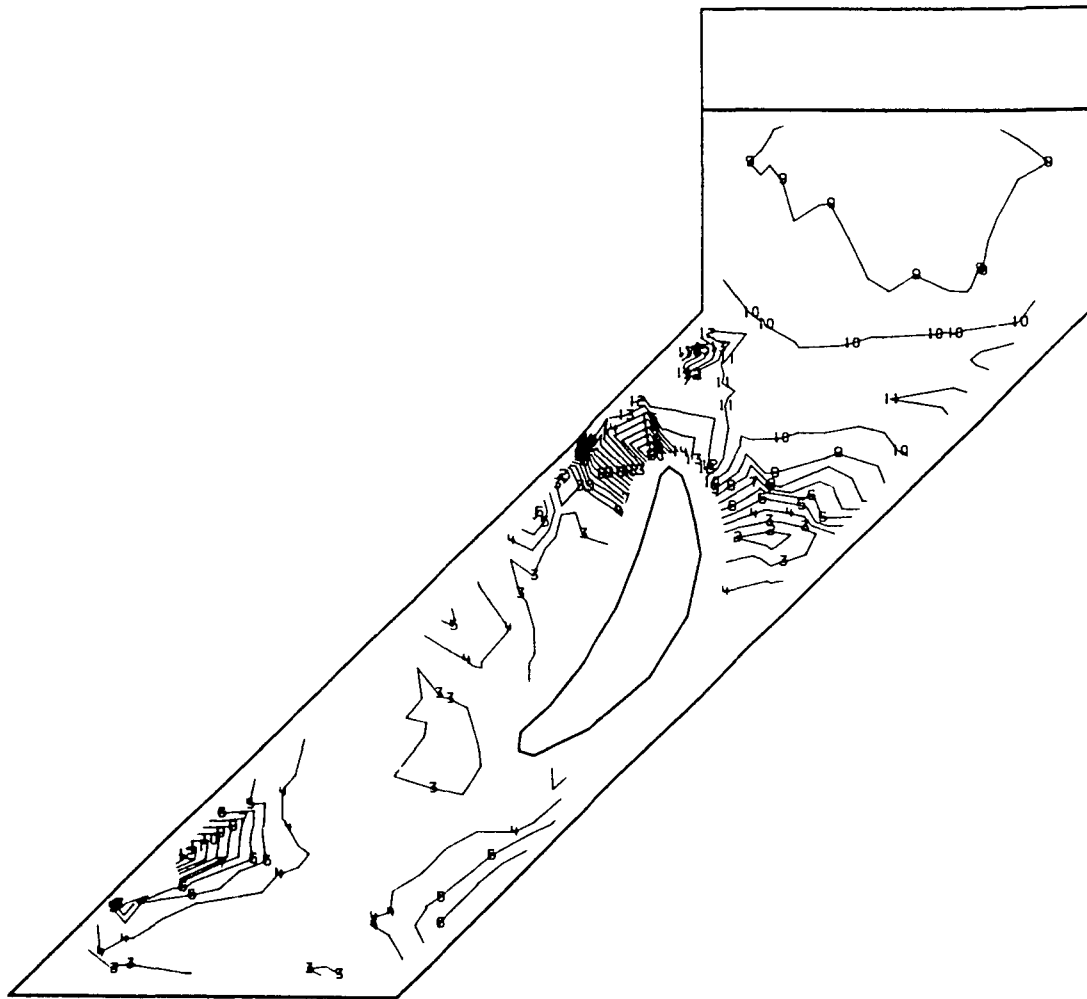

1	0.0	11	1.508975E 05
2	1.508975E 04	12	1.659873E 05
3	3.017951E 04	13	1.810770E 05
4	4.526926E 04	14	1.961668E 05
5	6.035902E 04	15	2.112565E 05
6	7.544875E 04	16	2.263463E 05
7	9.053850E 04	17	2.414360E 05
8	1.056283E 05	18	2.565258E 05
9	1.207180E 05	19	2.716155E 05
10	1.358078E 05	20	2.867054E 05

Fig. 3.4-42 Model 01, View 6, 115% Load, Shear Maximum Stress (psi)

3.5 HPOTP SECOND STAGE NOZZLE STRESSES AT FPL AND 115% RPL

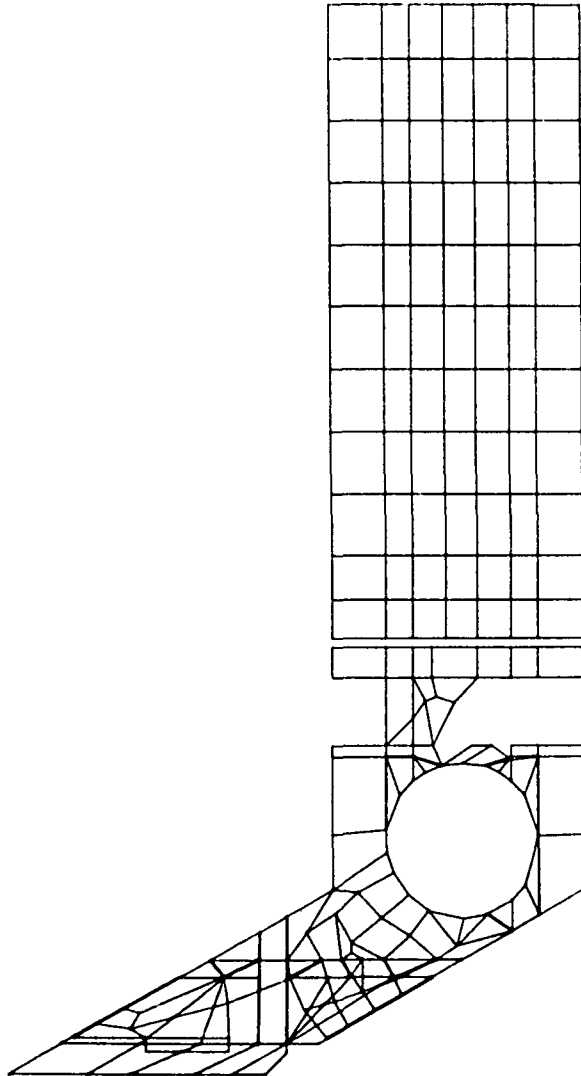
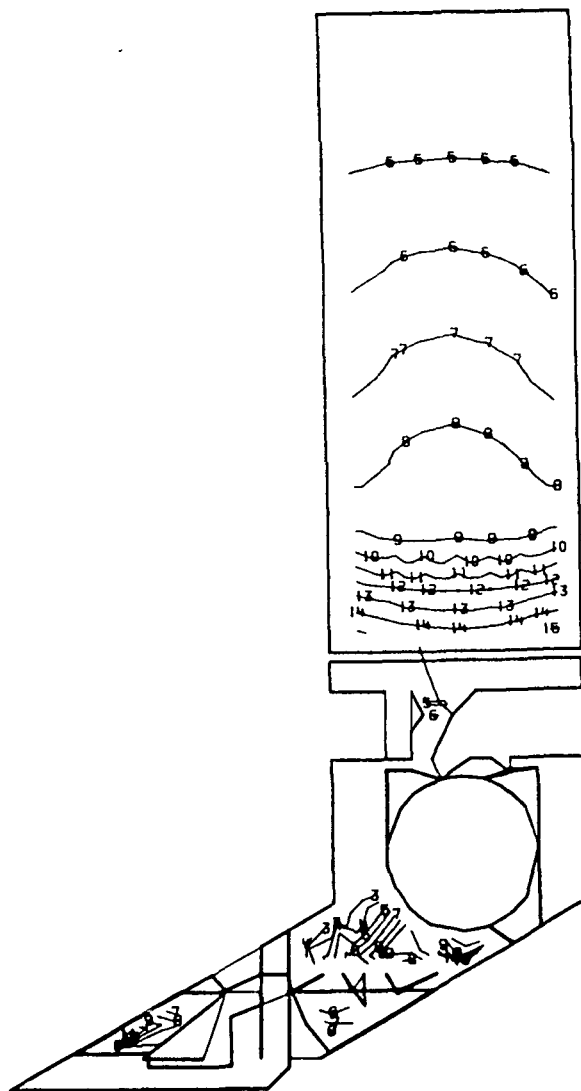
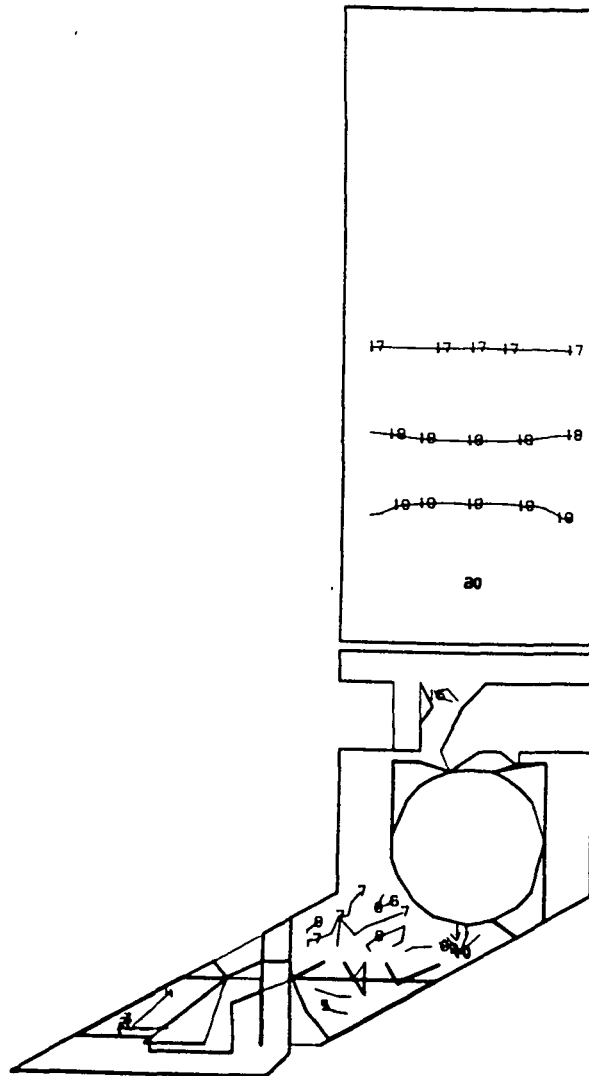

Fig. 3.5-1 Model 02, View 1, Shroud Outside



1	-3.214575E C4	11	7.419175E C4
2	-2.151200E C4	12	8.482550E C4
3	-1.087825E C4	13	9.545925E 04
4	-2.444961E C2	14	1.060930E C5
5	1.038925E C4	15	1.167268E 05
6	2.102300E C4	16	1.273605E C5
7	3.165675E C4	17	1.379943E C5
8	4.229050E C4	18	1.486280E C5
9	5.292425E C4	19	1.592618E C5
10	6.355800E C4	20	1.698956E C5

Fig. 3.5-2 Model 02, View 1, FPL Load, Major Principal Stress (psi)



1	-2.375524E C5	11	-8.200738E C4
2	-2.219979E C5	12	-6.645289E 04
3	-2.064424E C5	13	-5.089842E 04
4	-1.908889E C5	14	-3.534397E 04
5	-1.753344E C5	15	-1.978952E C4
6	-1.597799E C5	16	-4.225063E 03
7	-1.442254E C5	17	1.131939E 04
8	-1.286709E C5	18	2.687384E C4
9	-1.131164E C5	19	4.242830E C4
10	-9.756188E C4	20	5.798228E 04

Fig. 3.5-3 Model 02, View 1, FPL Load, Minor Princial Stress (psi)

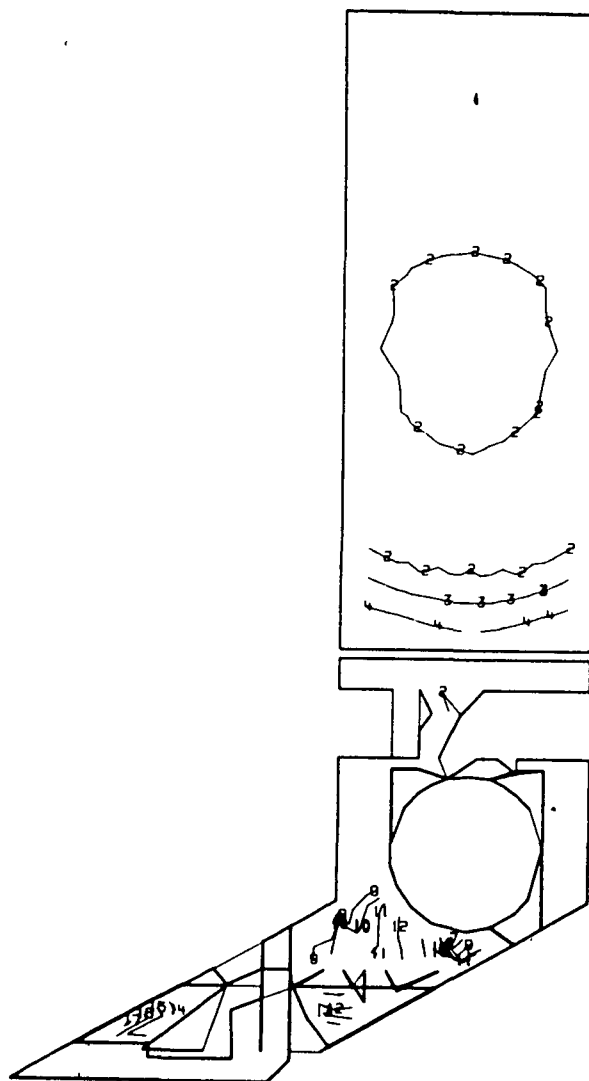

1	2.573408E C2	11	8.452200E C4
2	6.683816E C3	12	9.254844E C4
3	1.711029E C4	13	1.013749E 05
4	2.553677E C4	14	1.058013E 05
5	3.396325E C4	15	1.182278E 05
6	4.238572E C4	16	1.266542E C5
7	5.081620E C4	17	1.358066E 05
8	5.924268E C4	18	1.435071E C5
9	6.766913E C4	19	1.519335E C5
10	7.605556E C4	20	1.603604E C5

Fig. 3.5-4 Model 02, View 1, FPL Load, Shear Maximum Stress (psi)

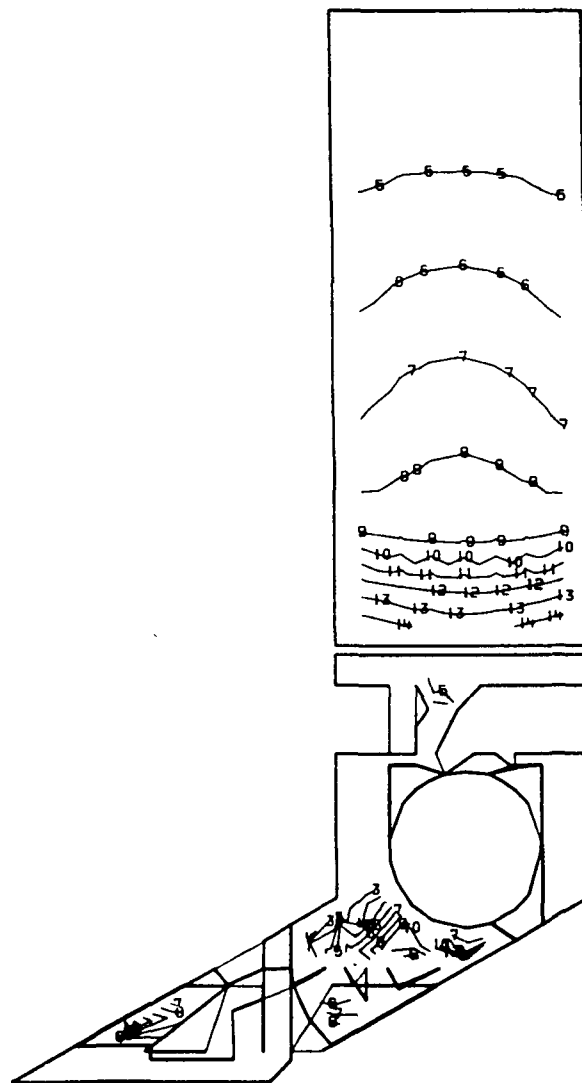

1	-3.647162E C4	11	8.950338E O4
2	-2.387412E C4	12	1.021009E O5
3	-1.127661E C4	13	1.146984E O5
4	1.320891E C3	14	1.272959E O5
5	1.391839E C4	15	1.398934E O5
6	2.651590E C4	16	1.524909E O5
7	3.911340E C4	17	1.650884E O5
8	5.171091E C4	18	1.776859E O5
9	6.430841E C4	19	1.902834E O5
10	7.690588E C4	20	2.028811E O5

Fig. 3.5-5 Model 02, View 1, 115% Load, Major Principal Stress (psi)

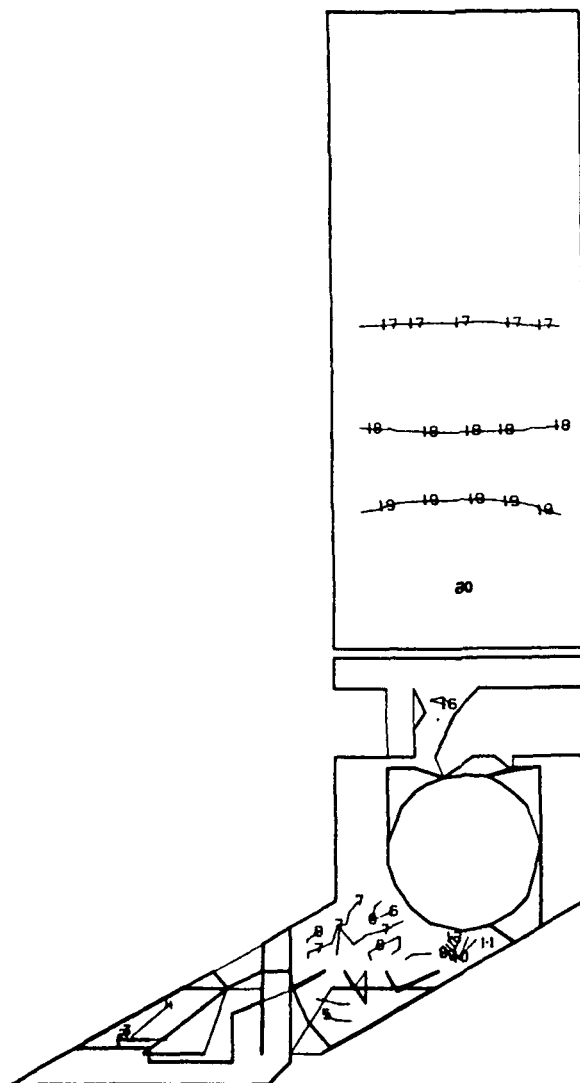

1	-2.790634E C5	11	-9.794775E 04
2	-2.609518E 05	12	-7.983619E 04
3	-2.428403E C5	13	-6.172465E 04
4	-2.247287E C5	14	-4.361311E 04
5	-2.066171E C5	15	-2.550157E 04
6	-1.885056E C5	16	-7.390031E 03
7	-1.703940E 05	17	1.072151E 04
8	-1.522824E C5	18	2.883305E 04
9	-1.341709E C5	19	4.694459E 04
10	-1.160593E C5	20	6.505596E 04

Fig. 3.5-6 Model 02, View 1, 115% Load, Minor Principal Stress (psi)

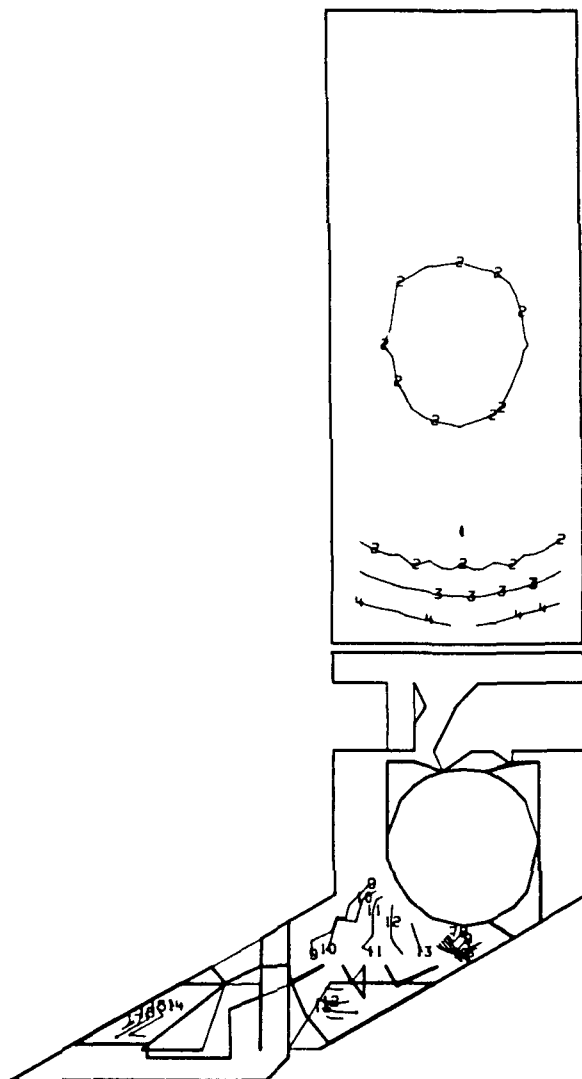

1	1.99578CE C2	11	9.985831E 04
2	1.016545E C4	12	1.098242E 05
3	2.013123E C4	13	1.197901E 05
4	3.009721E C4	14	1.297559E 05
5	4.006309E C4	15	1.397218E 05
6	5.002897E C4	16	1.496877E 05
7	5.999485E C4	17	1.596536E 05
8	6.996069E C4	18	1.696194E 05
9	7.992656E C4	19	1.795853E 05
10	8.989244E C4	20	1.895514E 05

Fig. 3.5-7 Model O2, View 1, 115% Load, Shear Maximum Stress (psi)

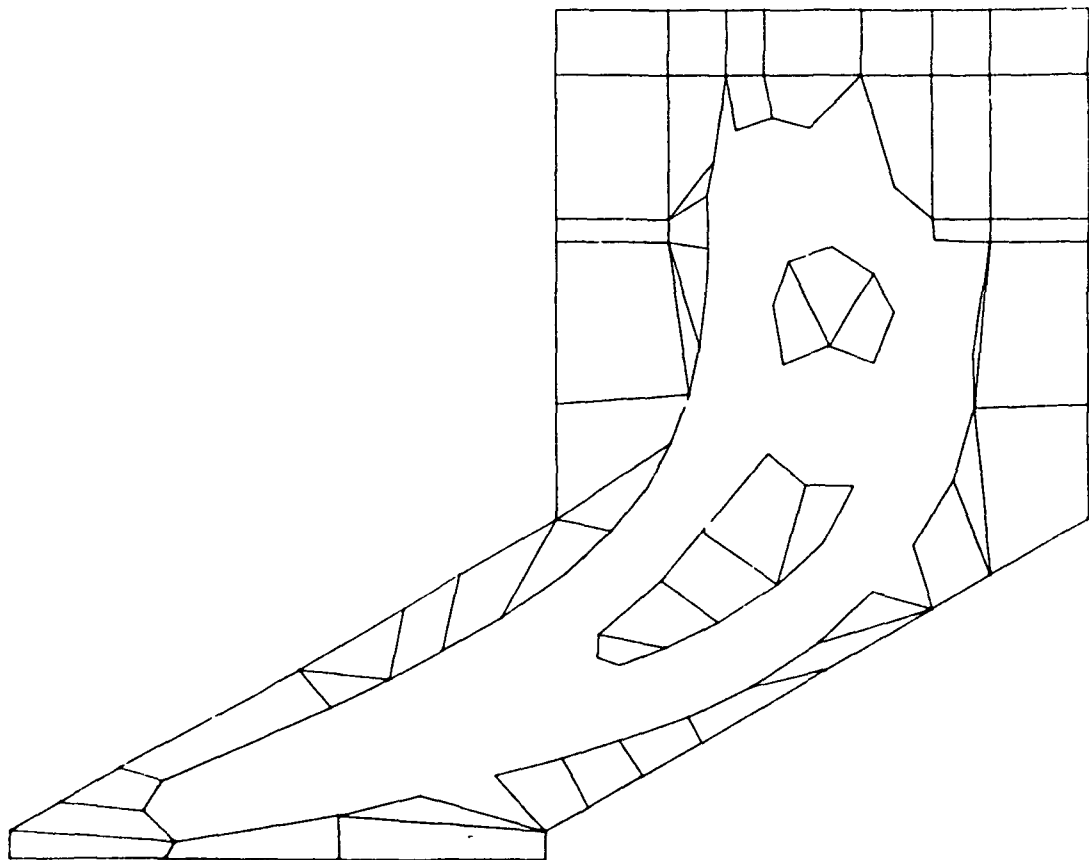
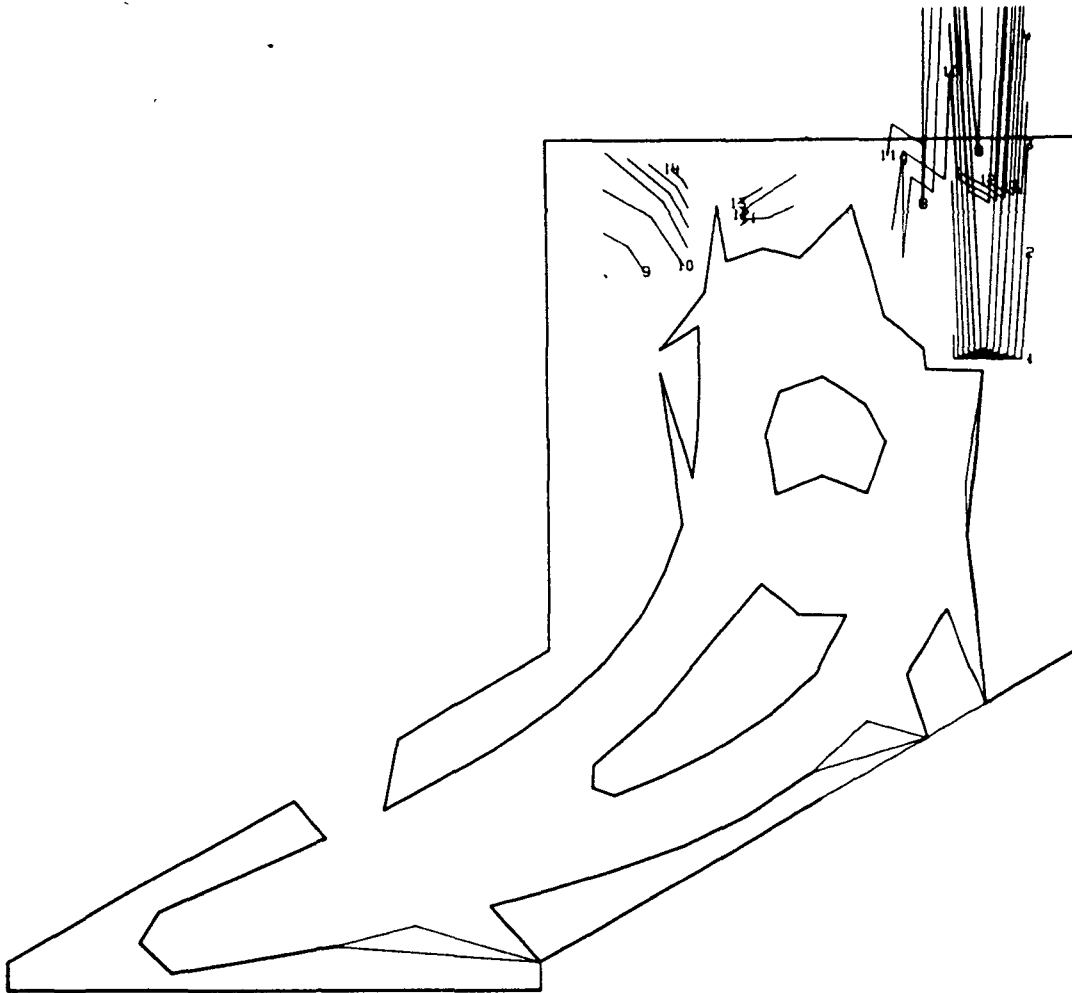
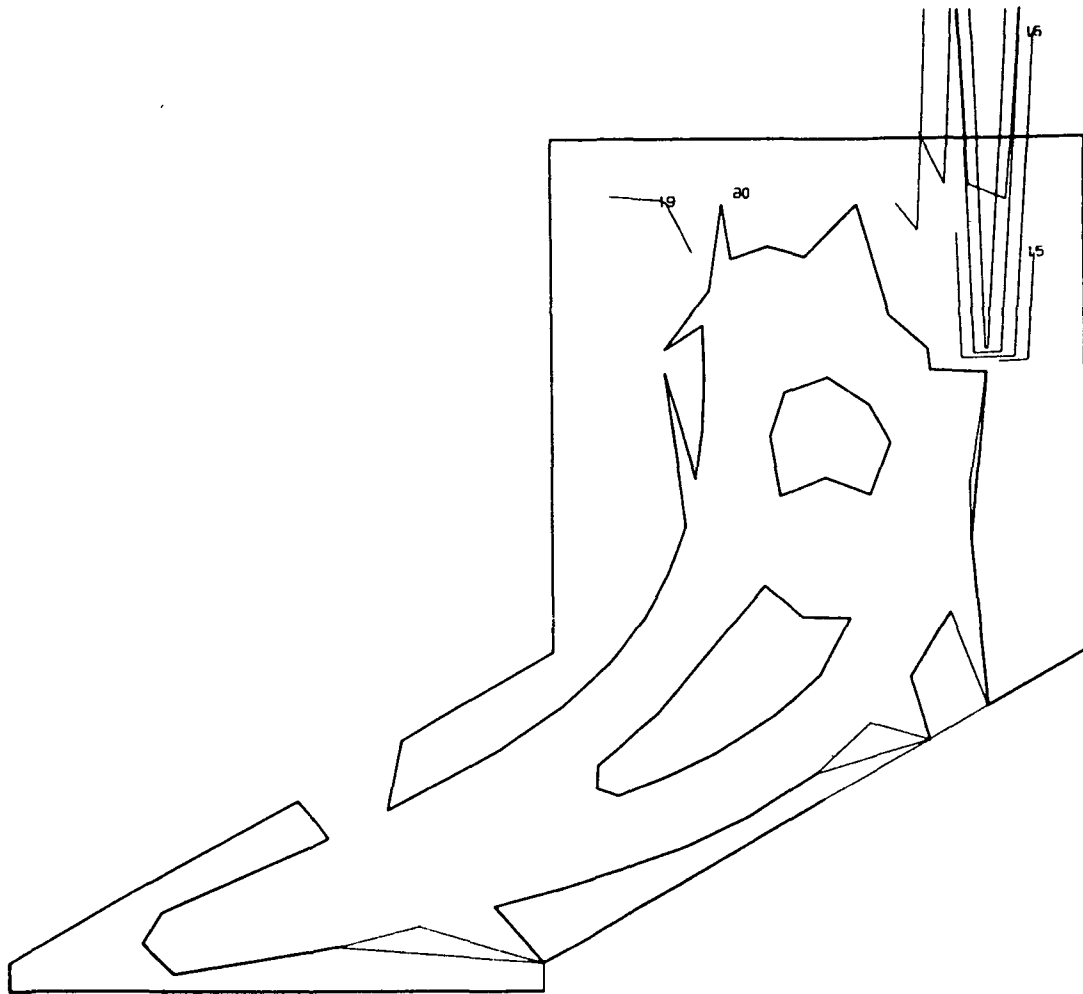

Fig. 3.5-8 Model 02, View 2, Shroud Foil Side



1	-6.384615E C4	11	3.913422E 03
2	-5.707019E C4	12	1.068938E 04
3	-5.029423E C4	13	1.746534E 04
4	-4.351828E C4	14	2.424129E 04
5	-3.674232E 04	15	3.101725E 04
6	-2.996636E C4	16	3.779321E 04
7	-2.319041E C4	17	4.456916E 04
8	-1.641445E C4	18	5.134512E C4
9	-9.638492E 03	19	5.812108E 04
10	-2.862535E C3	20	6.489706E 04

Fig. 3.5-9 Model 02, View 2, FPL Load, Major Principal Stress (psi)



1	-2.972537E 05	11	-1.433087E 05
2	-2.818592E 05	12	-1.279142E 05
3	-2.664647E 05	13	-1.125197E 05
4	-2.510702E 05	14	-9.712519E 04
5	-2.356757E 05	15	-8.173069E 04
6	-2.202812E 05	16	-6.633619E 04
7	-2.048867E 05	17	-5.094173E 04
8	-1.894922E 05	18	-3.554727E 04
9	-1.740977E 05	19	-2.015280E 04
10	-1.587032E 05	20	-4.758840E 03

Fig. 3.5-10 Model 02, View 2, FPL Load, Minor Principal Stress (psi)

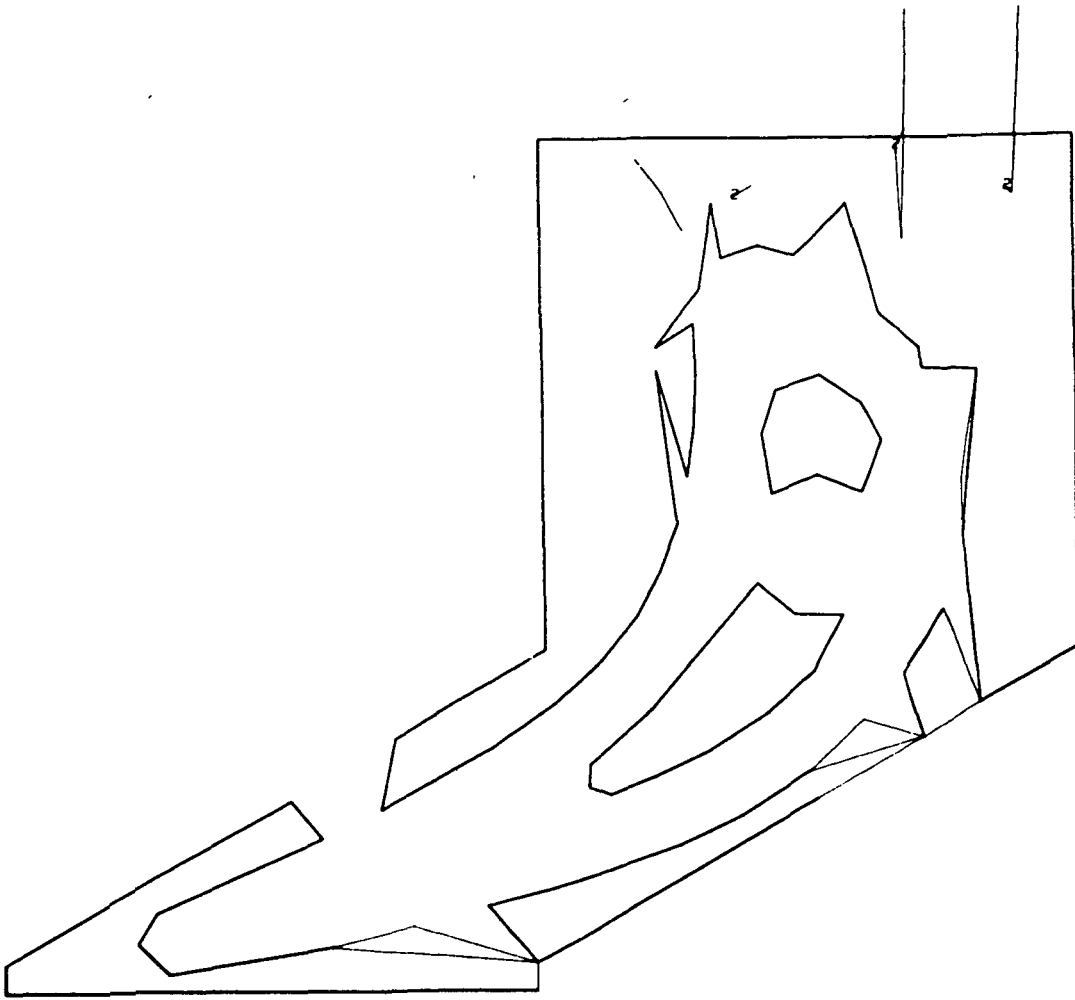

1	4.54543CE C3	11	8.778788E 04
2	1.286568E C4	12	9.611213E 04
3	2.119393E C4	13	1.044364E C5
4	2.951818E C4	14	1.127606E C5
5	3.784243E C4	15	1.210849E C5
6	4.616668E C4	16	1.294091E C5
7	5.449093E C4	17	1.377334E C5
8	6.281518E C4	18	1.460576E C5
9	7.113938E C4	19	1.543819E C5
10	7.946363E C4	20	1.627063E C5

Fig. 3.5-11 Model 02, View 2, FPL Load, Shear Maximum Stress (psi)

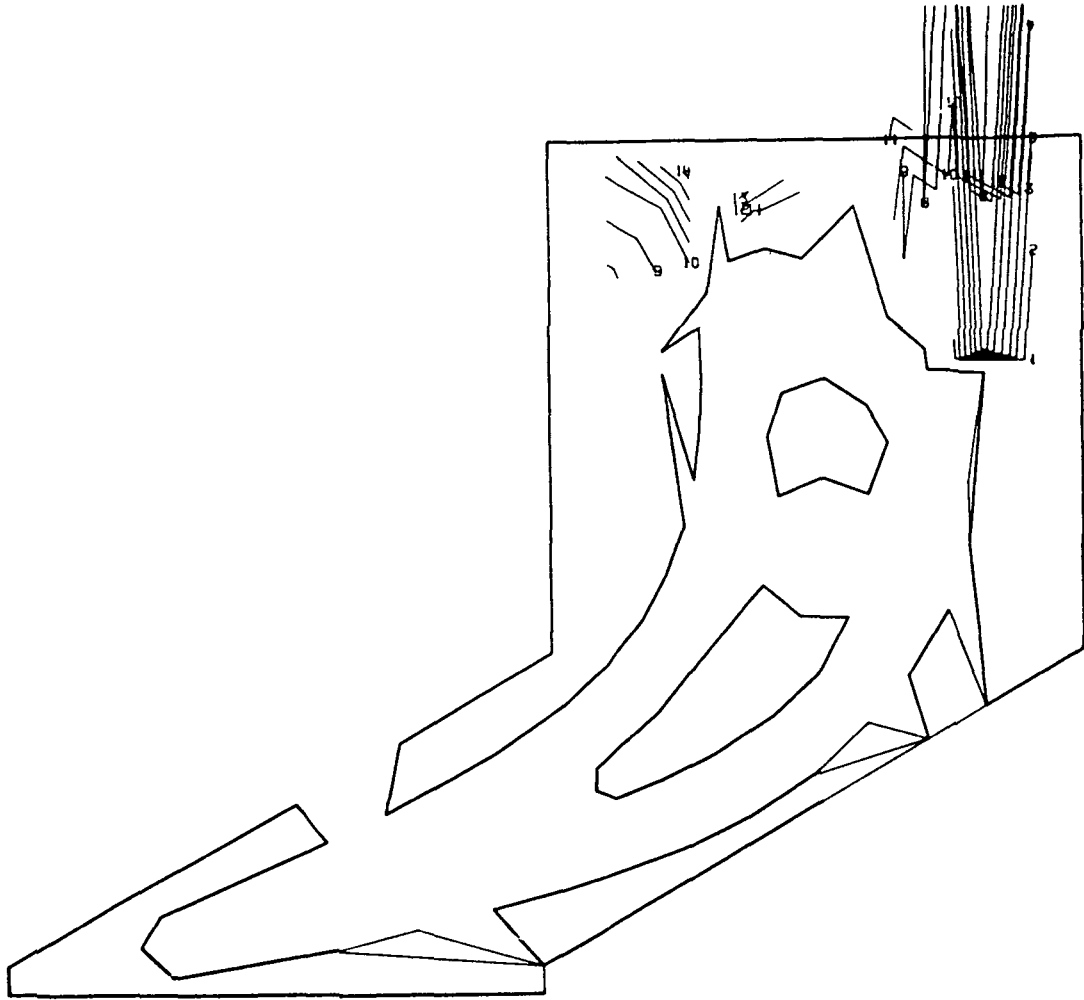

1	-7.774769E C4	11	5.153563E 03
2	-6.945756E C4	12	1.344369E 04
3	-6.116744E 04	13	2.173381E 04
4	-5.287731E C4	14	3.002394E 04
5	-4.458719E 04	15	3.831406E 04
6	-3.629706E C4	16	4.660419E 04
7	-2.800694E C4	17	5.489431E 04
8	-1.971681E C4	18	6.318444E 04
9	-1.142669E C4	19	7.147456E 04
10	-3.136563E C3	20	7.976475E 04

Fig. 3.5-12 Model 02, View 2, 115% Load, Major Principal Stress (psi)

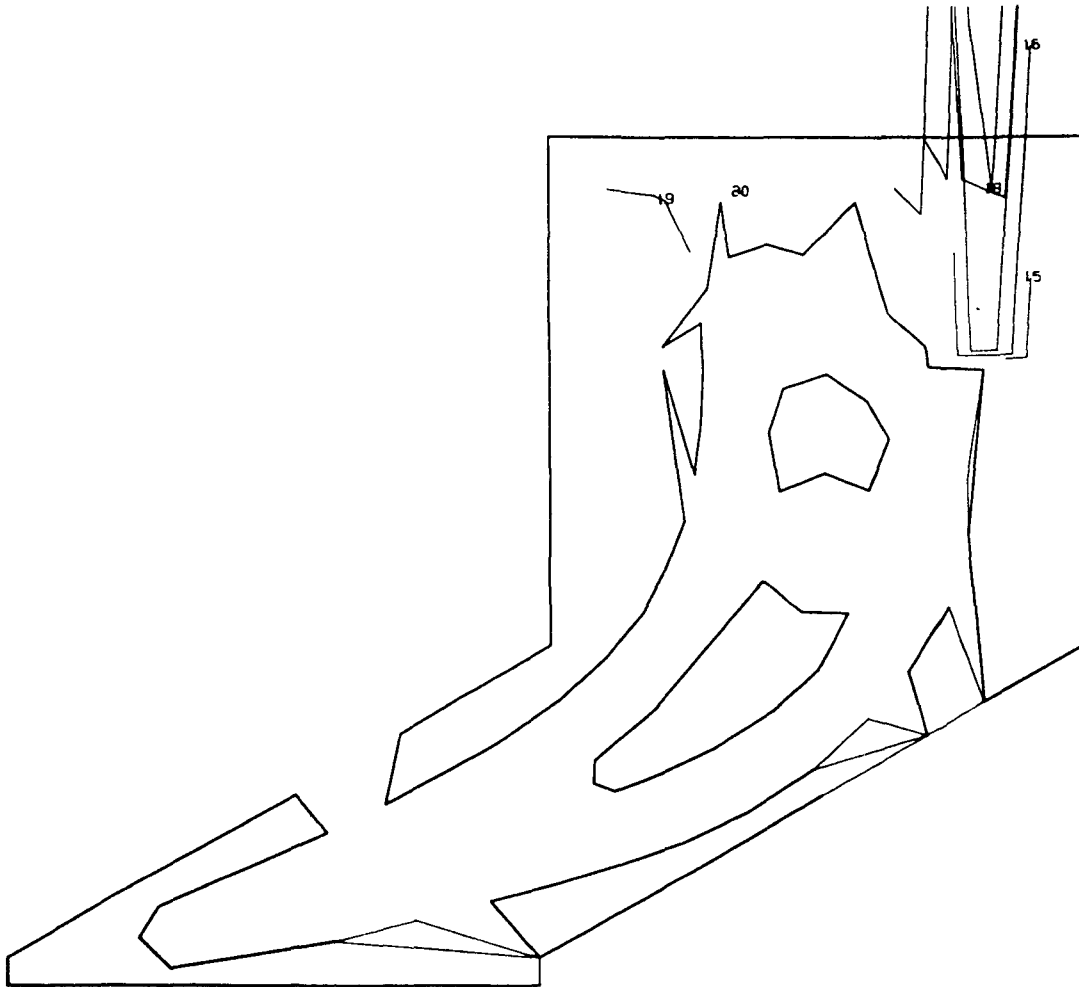

1	-3.4946C1E C5	11	-1.680132E 05
2	-3.313154E C5	12	-1.498685E 05
3	-3.1317C7E C5	13	-1.317238E 05
4	-2.95026CE C5	14	-1.135791E 05
5	-2.768813E C5	15	-9.543444E 04
6	-2.587366E C5	16	-7.728975E 04
7	-2.405919E 05	17	-5.914509E 04
8	-2.224473E C5	18	-4.100042E 04
9	-2.043026E C5	19	-2.285576E 04
10	-1.861579E C5	20	-4.711426E 03

Fig. 3.5-13 Model 02, View 2, 115% Load, Minor Principal Stress (psi)

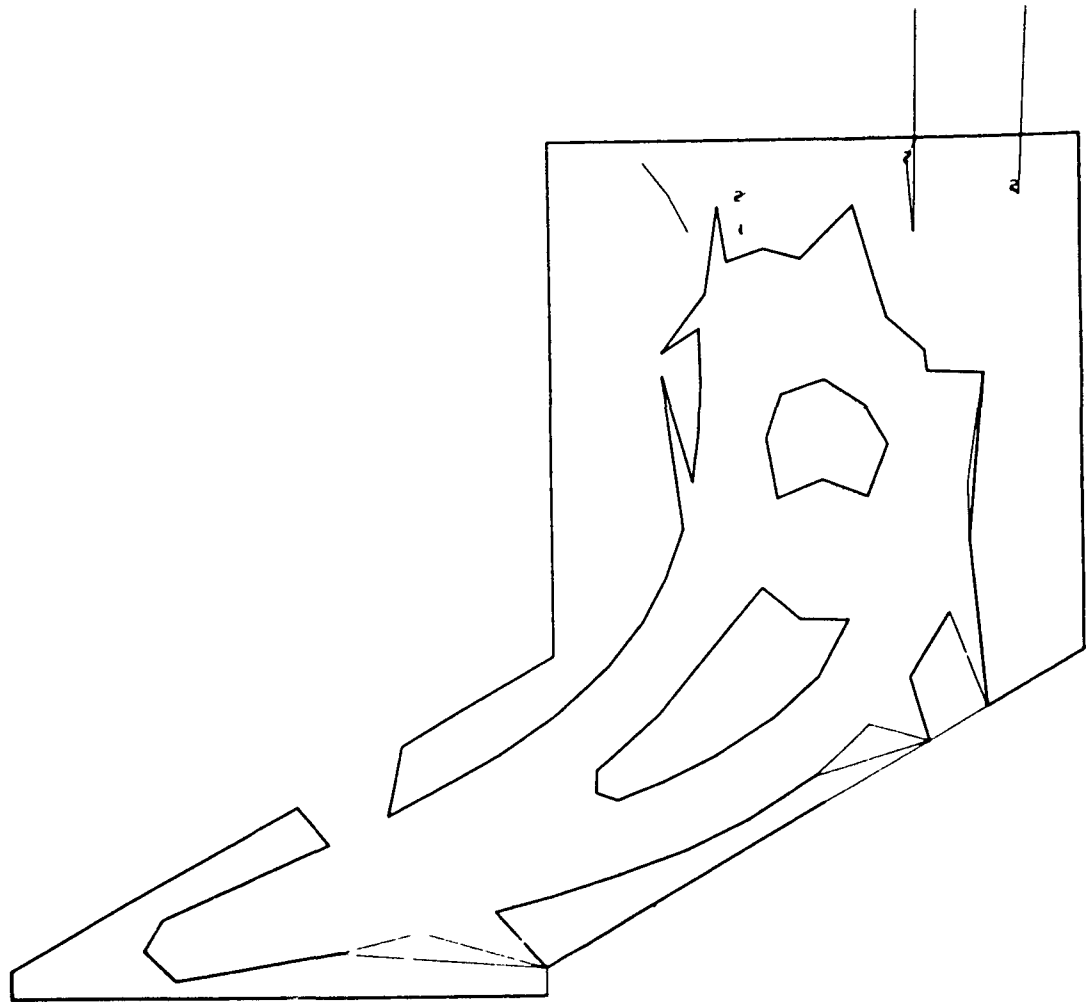

1	4.111793E 03	11	1.034308E 05
2	1.404371E C4	12	1.133627E 05
3	2.397563E C4	13	1.232946E 05
4	2.290755E C4	14	1.332264E 05
5	4.383946E C4	15	1.431583E 05
6	5.277128E C4	16	1.530902E 05
7	6.370330E C4	17	1.630221E 05
8	7.363519E C4	18	1.729539E 05
9	8.256706E C4	19	1.828858E 05
10	9.349854E C4	20	1.928183E 05

Fig. 3.5-14 Model 02, View 2, 115% Load, Shear Maximum Stress (psi)

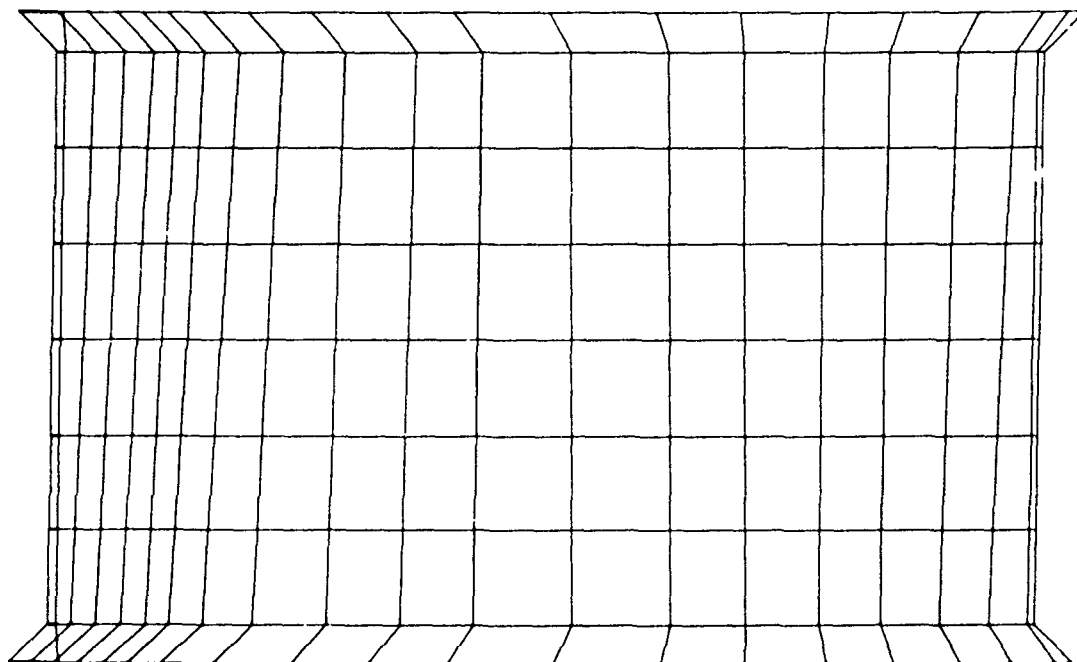
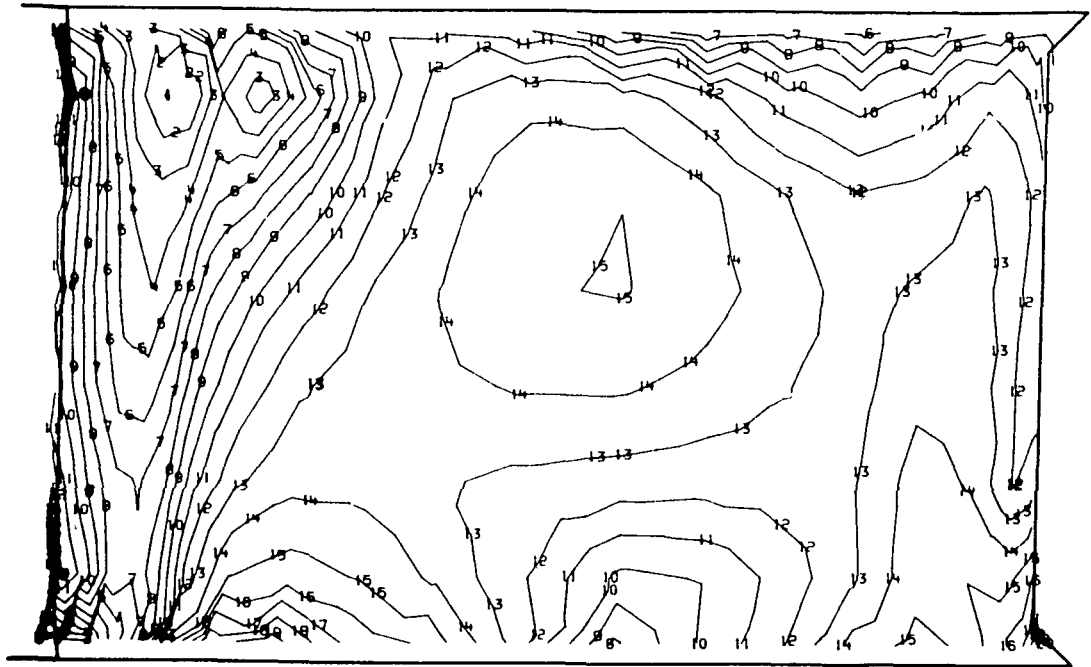
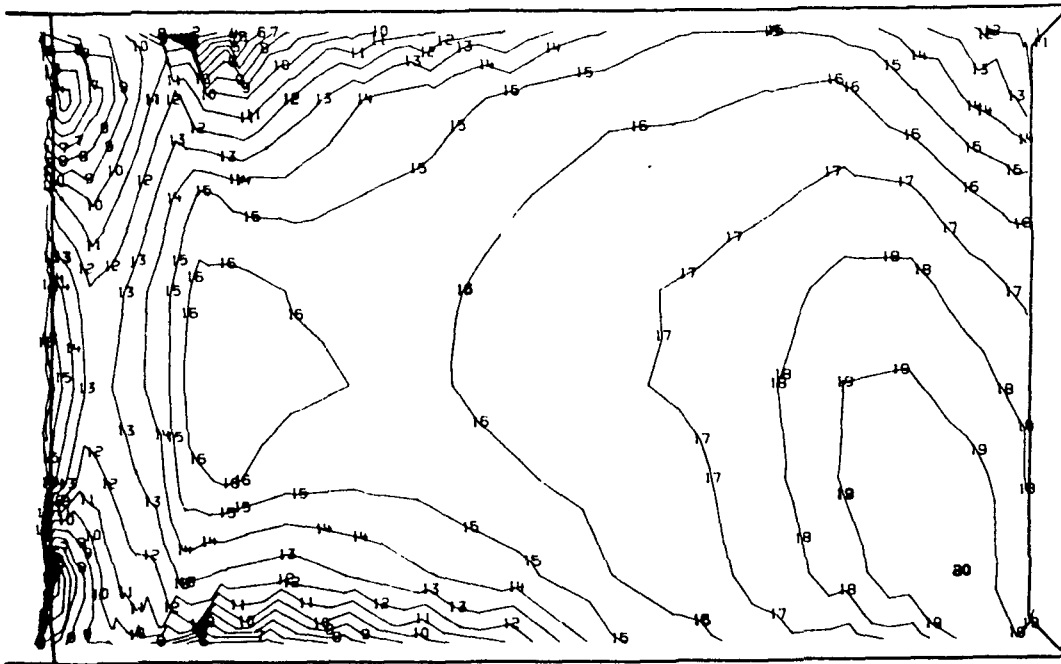

Fig. 3.5-15 Model 02, View 3, Foil Suction Side



1	-8.777463E C4	11	-2.830031E 03
2	-7.928013E C4	12	5.664418E 03
3	-7.078563E C4	13	1.415887E 04
4	-6.229118E C4	14	2.265332E 04
5	-5.379673E C4	15	3.114777E 04
6	-4.530228E C4	16	3.964221E 04
7	-3.680783E C4	17	4.813666E 04
8	-2.831338E C4	18	5.662111E 04
9	-1.981893E C4	19	6.512556E 04
10	-1.132448E C4	20	7.361994E 04

Fig. 3.5-16 Model 02, View 3, FPL Load, Major Principal Stress (psi)



1	-2.826849E C5	11	-1.235911E 05
2	-2.667755E C5	12	-1.076818E 05
3	-2.508661E C5	13	-9.177238E 04
4	-2.349568E C5	14	-7.586300E 04
5	-2.190474E C5	15	-5.995368E 04
6	-2.031380E C5	16	-4.404435E C4
7	-1.872286E C5	17	-2.813503E C4
8	-1.713193E C5	18	-1.222570E C4
9	-1.554099E C5	19	3.683621E 03
10	-1.395005E C5	20	1.959236E 04

Fig. 3.5-17 Model 02, View 3, FPL Load, Minor Principal Stress (psi)

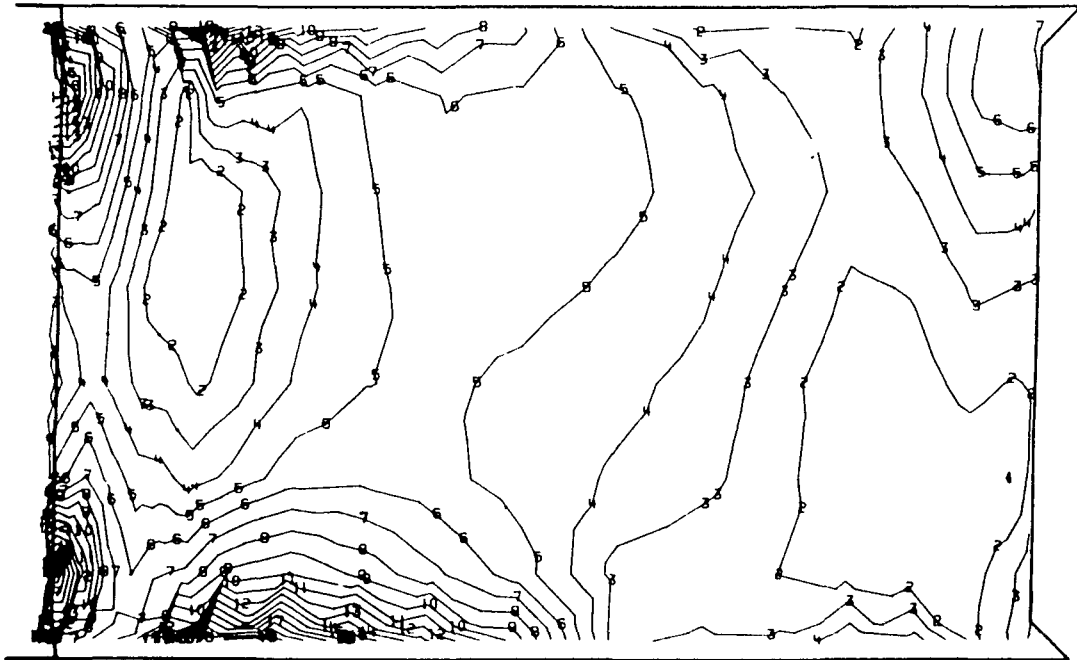

1	2.959029E C3	11	7.635181E C4
2	1.029831E C4	12	8.369106E 04
3	1.763760E C4	13	9.103031E 04
4	2.497688E C4	14	9.836955E C4
5	3.231617E C4	15	1.057089E C5
6	3.965545E C4	16	1.130481E C5
7	4.699474E C4	17	1.203973E C5
8	5.433402E C4	18	1.277266E 05
9	6.167331E C4	19	1.350658E C5
10	6.901256E C4	20	1.424055E C5

Fig. 3.5-18 Model 02, View 3, FPL Load, Shear Maximum Stress (psi)

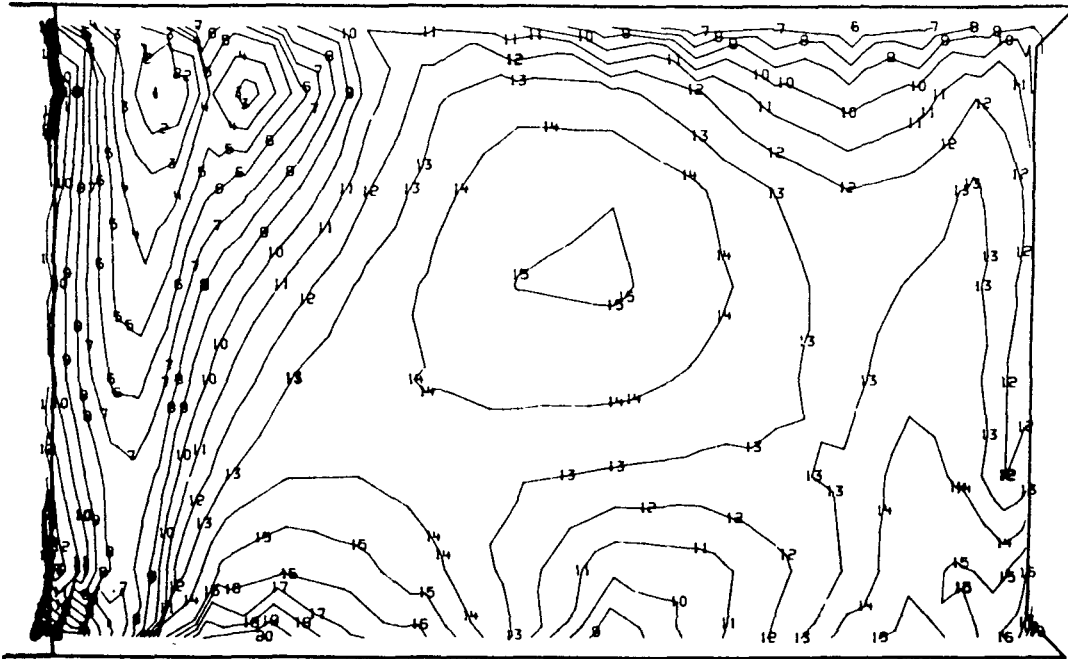

1	-1.050481E C5	11	-3.807848E 03
2	-5.452400E C4	12	6.316156E C3
3	-8.479954E C4	13	1.644016E 04
4	-7.467588E C4	14	2.656416E 04
5	-6.455187E C4	15	3.668817E 04
6	-5.442787E C4	16	4.681217E 04
7	-4.430386E C4	17	5.693618E 04
8	-3.417986E C4	18	6.706013E 04
9	-2.405586E C4	19	7.718413E 04
10	-1.393185E C4	20	8.730806E 04

Fig. 3.5-19 Model 02, View 3, 115% Load, Major Principal Stress (psi)

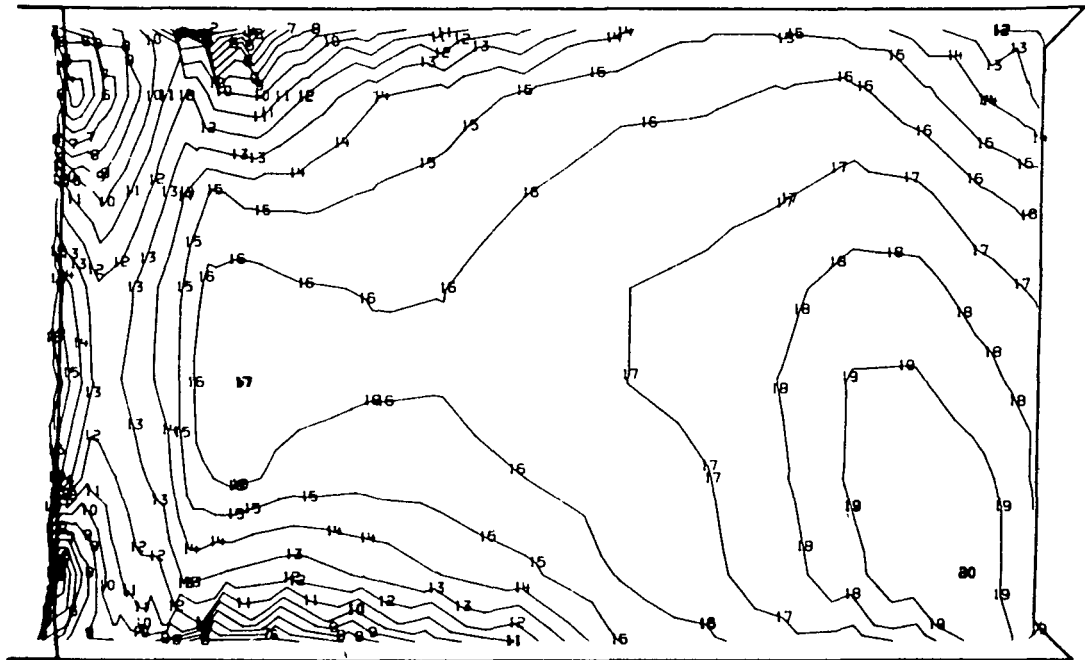

1	-3.322610E C5	11	-1.454316E 05
2	-3.135781E C5	12	-1.267487E 05
3	-2.948951E C5	13	-1.080658E 05
4	-2.762122E C5	14	-8.938281E 04
5	-2.575293E C5	15	-7.069988E 04
6	-2.388463E C5	16	-5.201695E 04
7	-2.201634E C5	17	-3.333403E 04
8	-2.014804E 05	18	-1.465111E 04
9	-1.827975E C5	19	4.031813E 03
10	-1.641146E C5	20	2.271457E 04

Fig. 3.5-20 Model 02, View 3, 115% Load, Minor Principal Stress (psi)

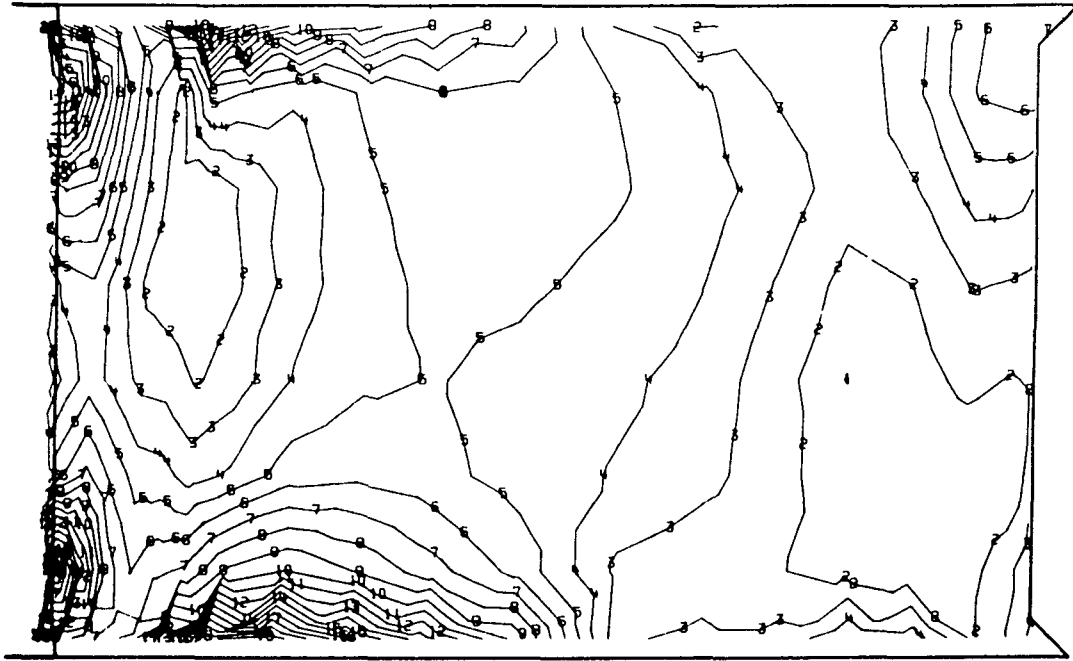

1	3.307030E C3	11	9.142844E 04
2	1.211513E C4	12	1.002406E 05
3	2.093132E C4	13	1.090527E 05
4	2.974347E C4	14	1.178648E 05
5	3.855562E C4	15	1.266769E 05
6	4.736777E C4	16	1.354891E 05
7	5.617992E C4	17	1.443012E 05
8	6.499207E C4	18	1.531133E 05
9	7.380419E C4	19	1.619254E 05
10	8.261631E C4	20	1.707379E 05

Fig. 3.5-21 Model 02, View 3, 115% Load, Shear Maximum Stress (psi)

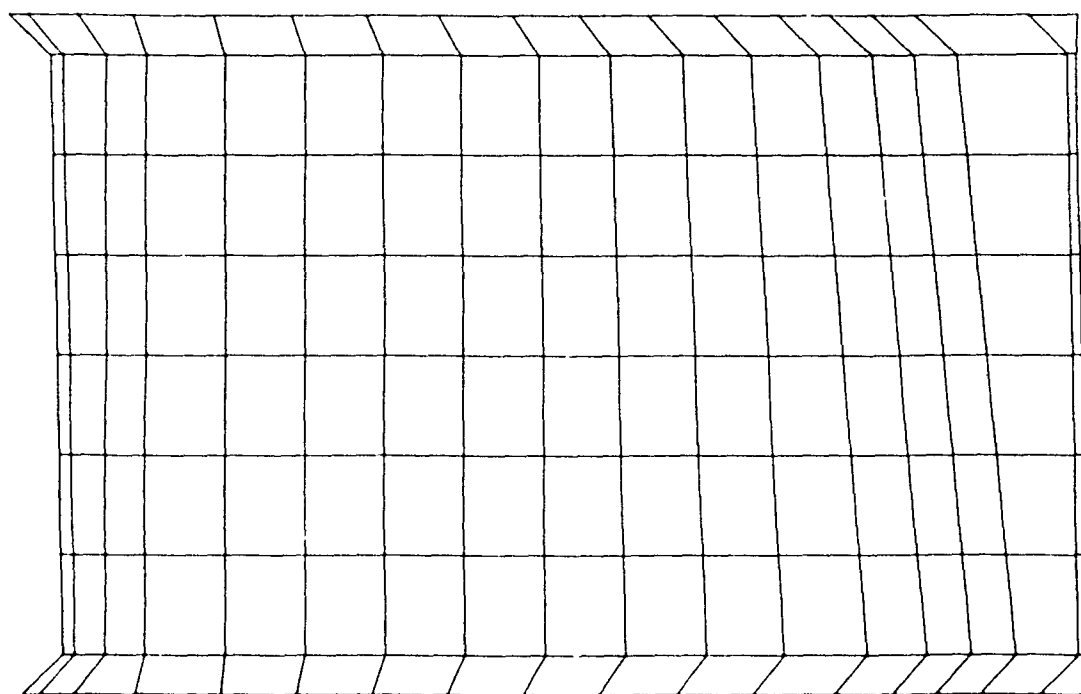
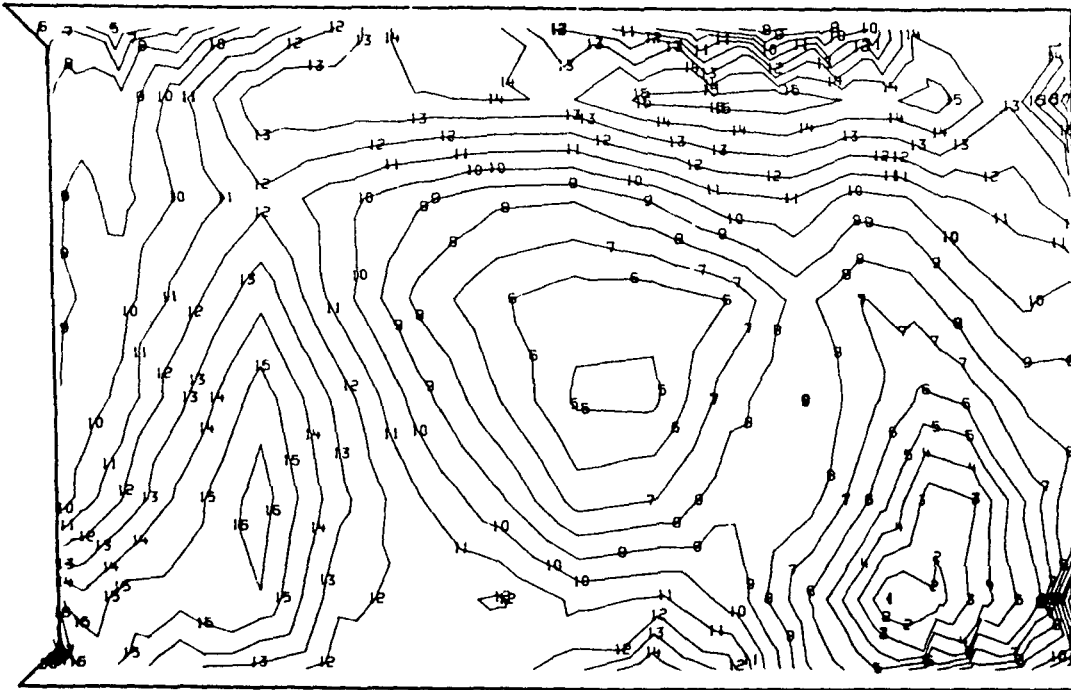
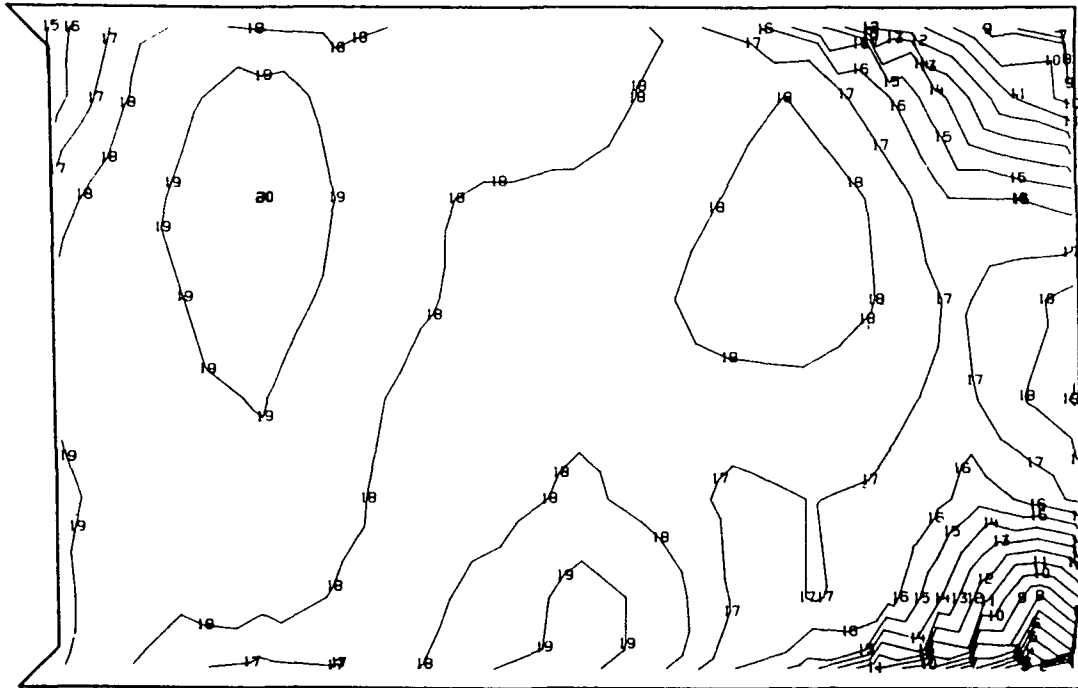

Fig. 3.5-22 Model 02, View 4, Foil Pressure Side



1	-5.653194E C4	11	1.264056E C4
2	-4.561469E C4	12	1.955781E C4
3	-4.269744E C4	13	2.647506E 04
4	-3.578019E C4	14	3.339231E C4
5	-2.886294E C4	15	4.030956E 04
6	-2.194569E C4	16	4.722681E 04
7	-1.502844E C4	17	5.414406E 04
8	-8.111188E C3	18	6.106131E C4
9	-1.193928E C3	19	6.797856E C4
10	-5.723313E C3	20	7.489581E 04

Fig. 3.5-23 Model O2, View 4, FPL Load, Major Principal Stress (psi)



1	-4.162374E C5	11	-1.932606E 05
2	-3.935398E C5	12	-1.709629E 05
3	-3.716421E C5	13	-1.486652E C5
4	-3.493444E C5	14	-1.263675E C5
5	-3.270467E C5	15	-1.040698E C5
6	-3.047490E C5	16	-8.17213E 04
7	-2.824513E C5	17	-5.947446E C4
8	-2.601536E C5	18	-3.717680E C4
9	-2.378559E C5	19	-1.487913E C4
10	-2.155583E C5	20	7.418195E 03

Fig. 3.5-24 Model 02, View 4, FPL Load, Minor Principal Stress (psi)

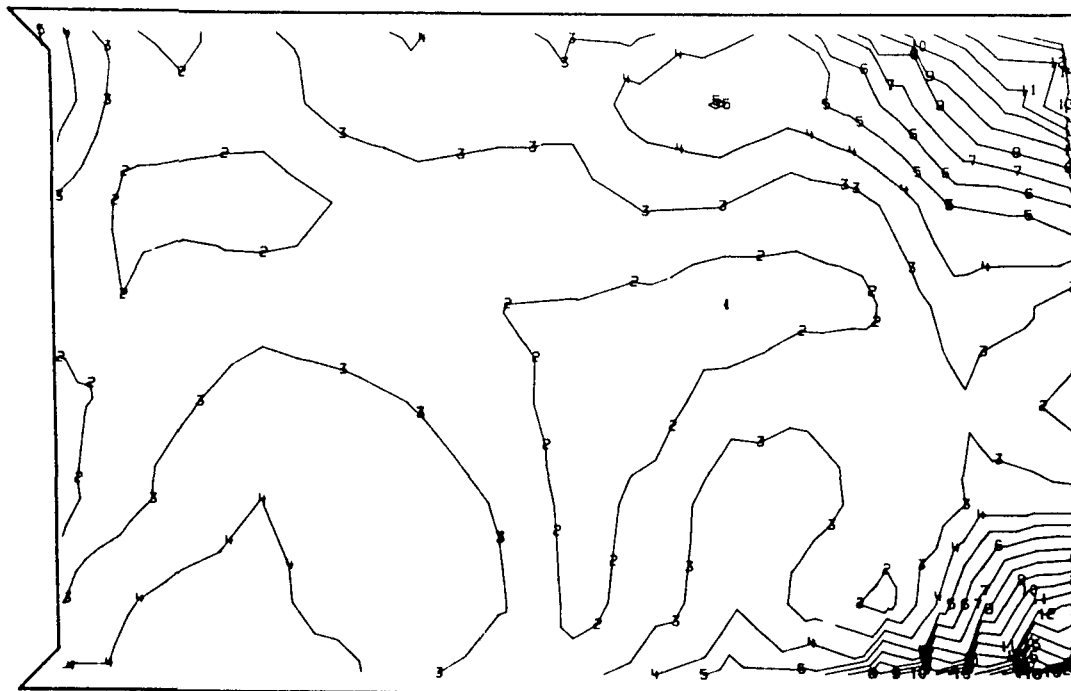

1	9.410310E C1	11	1.151404E C5
2	1.159875E C4	12	1.266451E C5
3	2.310340E C4	13	1.381497E C5
4	3.460805E C4	14	1.496543E C5
5	4.611270E C4	15	1.611589E C5
6	5.761735E C4	16	1.726636E C5
7	6.912194E C4	17	1.841682E C5
8	8.062656E C4	18	1.956728E C5
9	9.213119E C4	19	2.071774E C5
10	1.036358E C5	20	2.186825E C5

Fig. 3.5-25 Model 02, View 4, FPL Load, Shear Maximum Stress (psi)

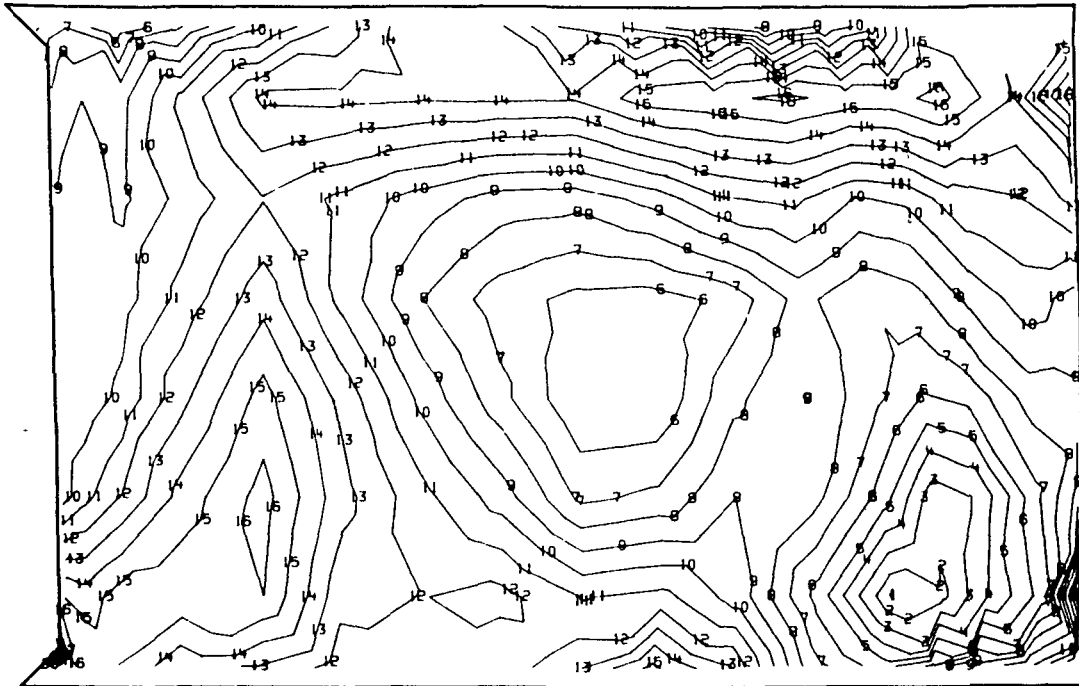

1	-6.656994E C4	11	1.342569E 04
2	-5.857038E C4	12	2.142525E 04
3	-5.057081E 04	13	2.942481E 04
4	-4.257125E C4	14	3.742438E 04
5	-3.457169E C4	15	4.542394E 04
6	-2.657213E C4	16	5.342350E 04
7	-1.857256E C4	17	6.142306E 04
8	-1.057300E C4	18	6.942263E 04
9	-2.577439E C3	19	7.742219E 04
10	5.426125E C3	20	8.542181E 04

Fig. 3.5-26 Model 02, View 4, 115% Load, Major Principal Stress (psi)

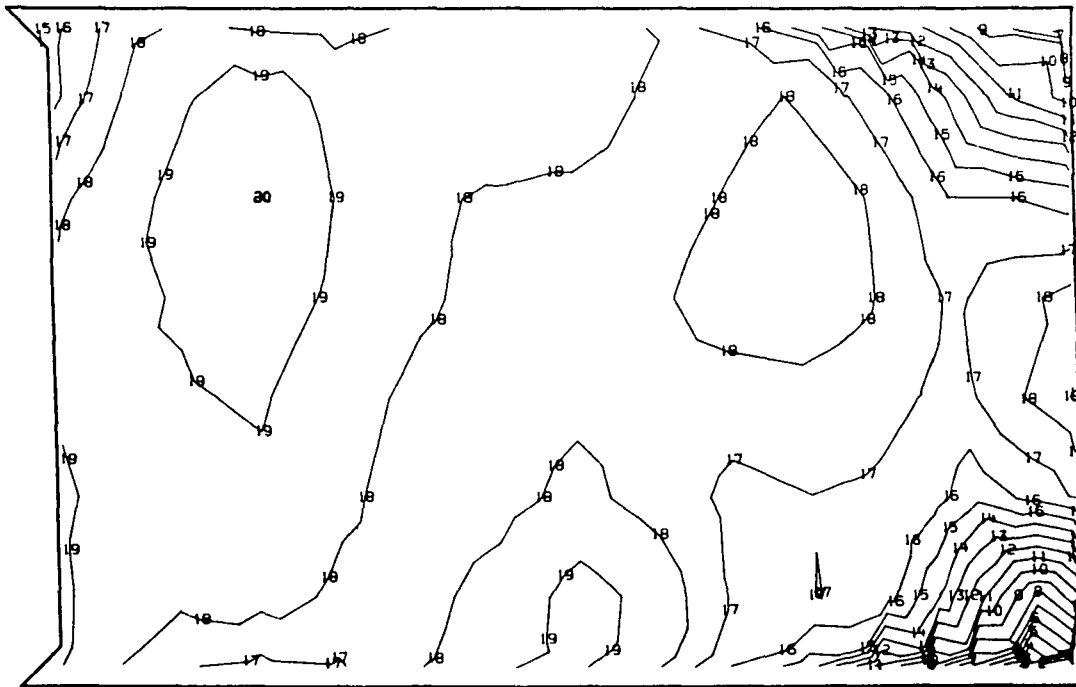

1	-4.936841F C5	11	-2.289029E 05
2	-4.67206CE C5	12	-2.024248E 05
3	-4.407279E C5	13	-1.759466E 05
4	-4.142498E C5	14	-1.494685E 05
5	-3.877716E C5	15	-1.229904E 05
6	-3.612935E 05	16	-9.651225F 04
7	-3.348154E C5	17	-7.003413E 04
8	-3.083373E C5	18	-4.355606E 04
9	-2.818591E C5	19	-1.707799E 04
10	-2.55391CE C5	20	9.399211E 03

Fig. 3.5-27 Model 02, View 4, 115% Load, Minor Principal Stress (psi)

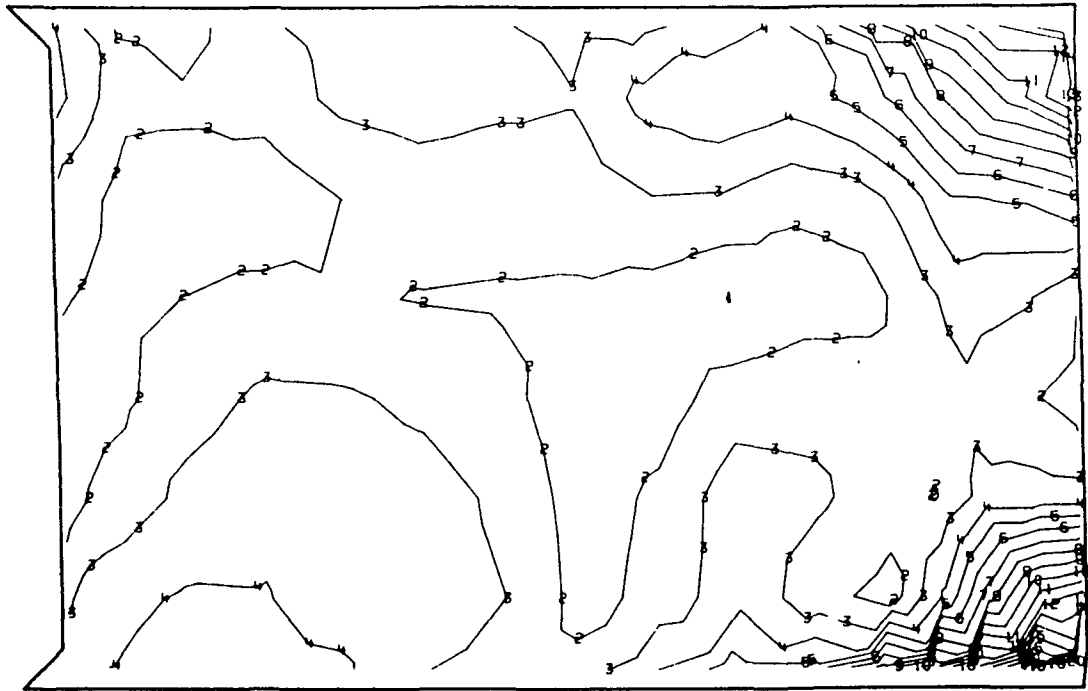

1	1.599537E C3	11	1.394090E 05
2	1.538050E C4	12	1.531899E 05
3	2.916146E 04	13	1.669709E 05
4	4.294243E C4	14	1.807513E 05
5	5.672339E C4	15	1.945328E 05
6	7.050431E C4	16	2.083137E 05
7	8.428525E C4	17	2.220946E 05
8	9.806619E C4	18	2.358756E 05
9	1.118471E C5	19	2.496565E 05
10	1.256281E C5	20	2.634379E 05

Fig. 3.5-28 Model 02, View 4, 115% Load, Shear Maximum Stress (psi)

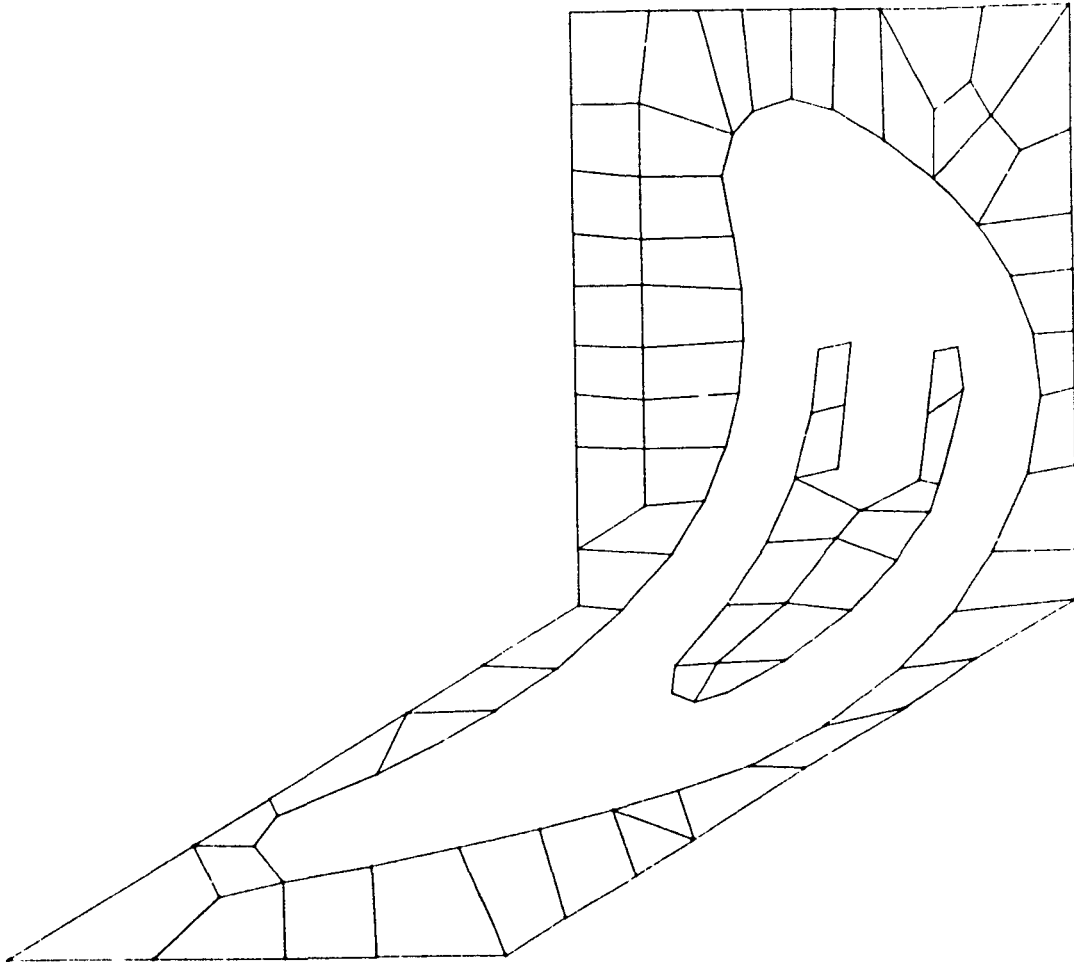
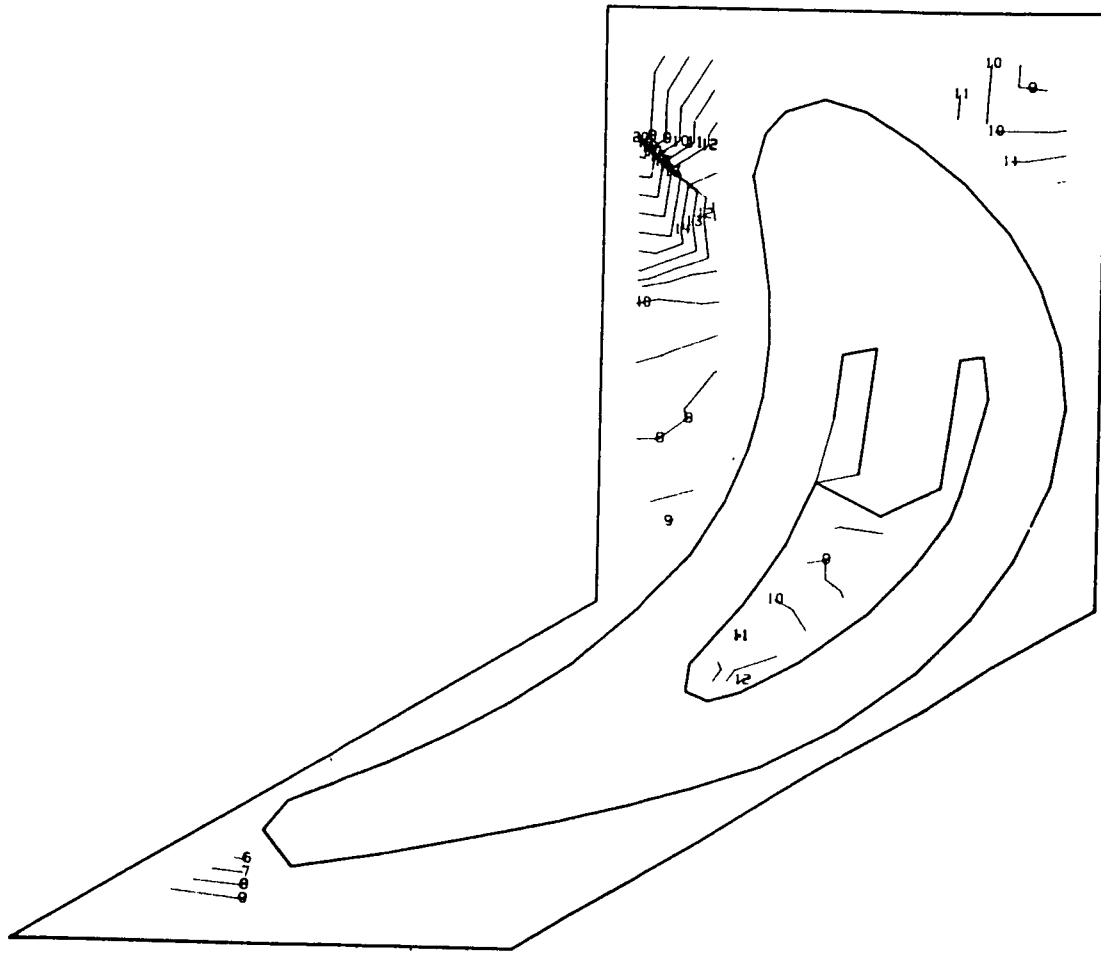
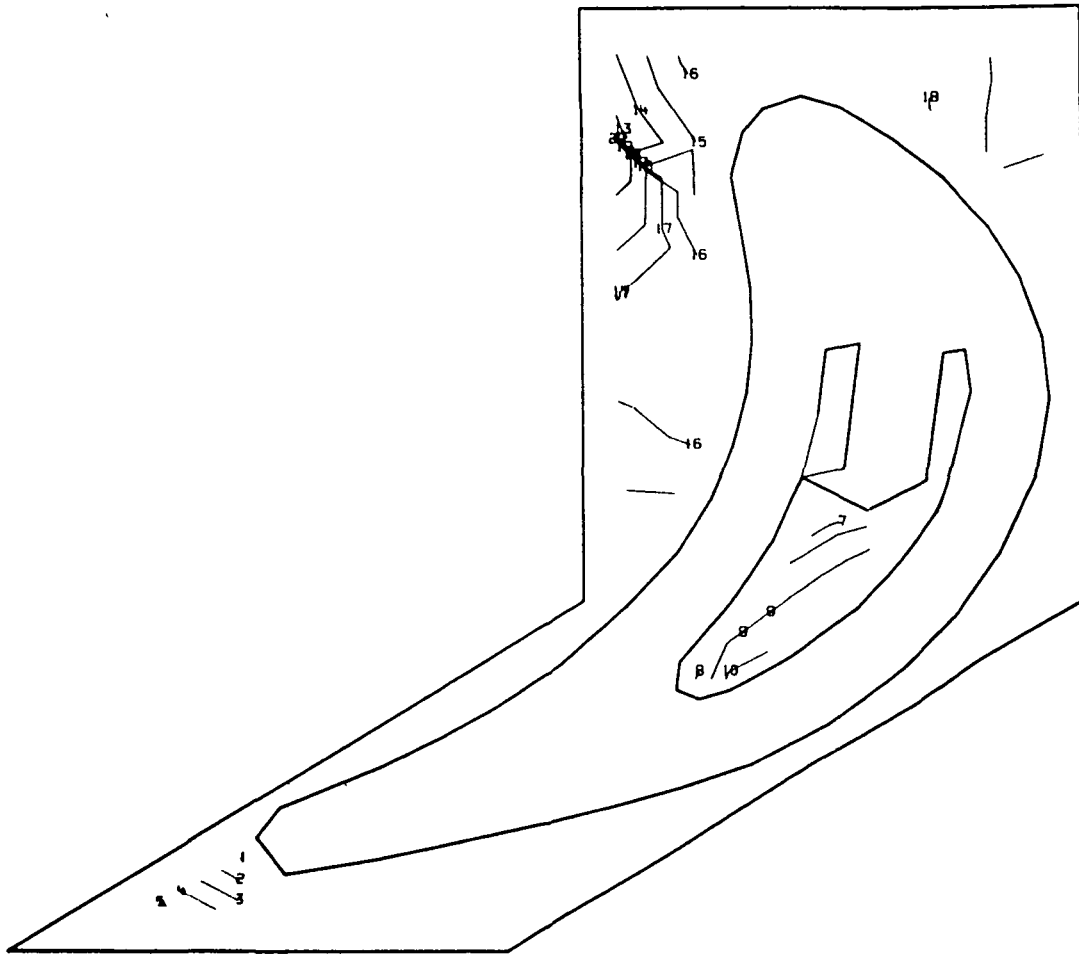

Fig. 3.5-29 Model 02, View 5, Hub Foil Side



1	-1.109424E C5	11	2.961754E C4
2	-9.688644E C4	12	4.367353E C4
3	-8.283044E C4	13	5.772953E C4
4	-6.877444E C4	14	7.178550E C4
5	-5.471844E C4	15	8.584144E C4
6	-4.066245E C4	16	9.989738E C4
7	-2.660645E C4	17	1.139533E C5
8	-1.255045E C4	18	1.280093E C5
9	1.505443E C3	19	1.420652E C5
10	1.556154E C4	20	1.561215E C5

Fig. 3.5-30 Model O2, View 5, FPL Load, Major Principal Stress (psi)



1	-3.336697E C5	11	-1.391479E C5
2	-3.138175E C5	12	-1.152956E C5
3	-2.939693E C5	13	-9.544344E 04
4	-2.741131E C5	14	-7.559125E 04
5	-2.542609E C5	15	-5.573910E 04
6	-2.344088E C5	16	-3.588695E 04
7	-2.145566E C5	17	-1.603480E 04
8	-1.947044E C5	18	3.817344E 03
9	-1.748522E C5	19	2.366949E 04
10	-1.550000E C5	20	4.352122E 04

Fig. 3.5-31 Model 02, View 5, FPL Load, Minor Principal Stress (psi)

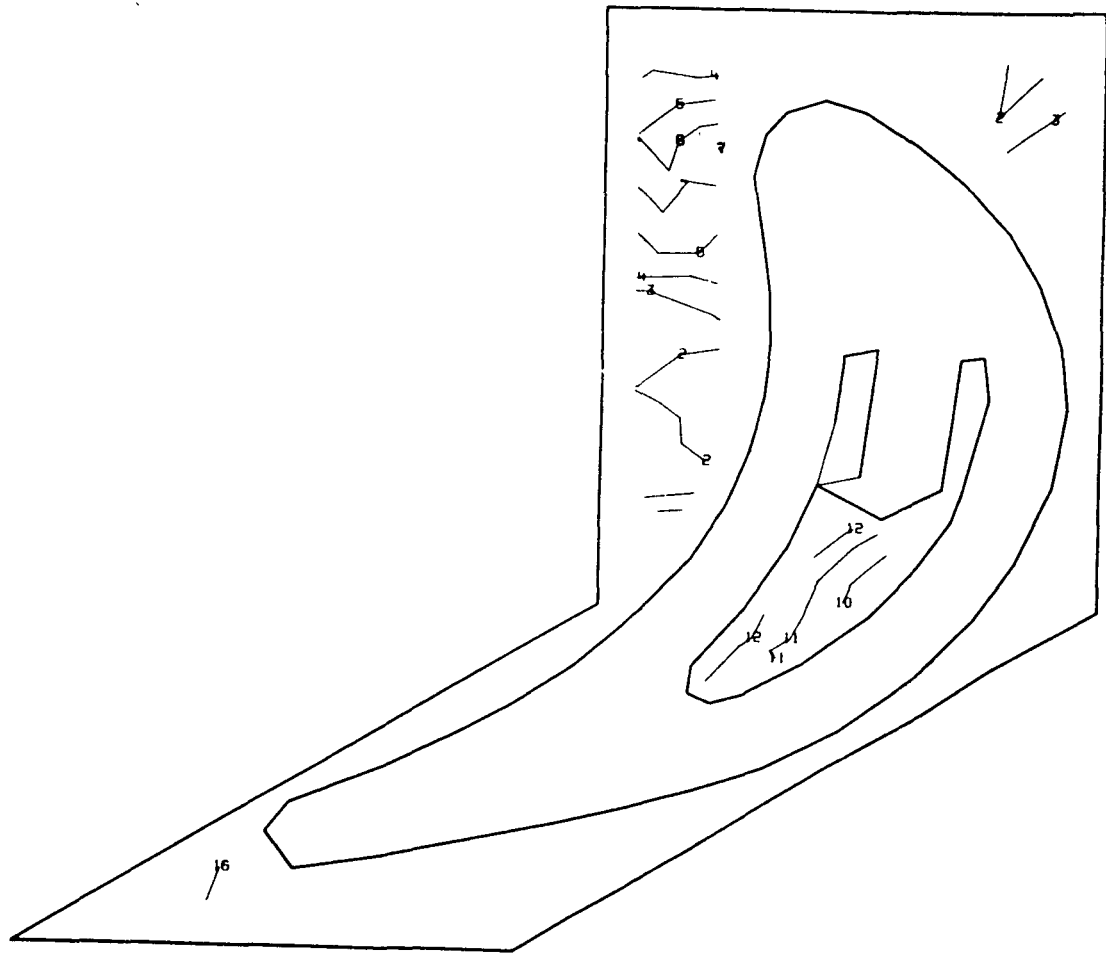

1	1.716545E C3	11	9.242225E C4
2	1.078712E C4	12	1.014928E 05
3	1.985769E C4	13	1.105634E C5
4	2.892827E C4	14	1.196339E 05
5	3.799984E C4	15	1.287045E 05
6	4.706941E C4	16	1.377751E C5
7	5.613999E C4	17	1.468456E 05
8	6.521056E C4	18	1.559162E 05
9	7.428113E C4	19	1.649868E 05
10	8.335169E C4	20	1.740575E C5

Fig. 3.5-32 Model 02, View 5, FPL Load, Shear Maximum Stress (psi)

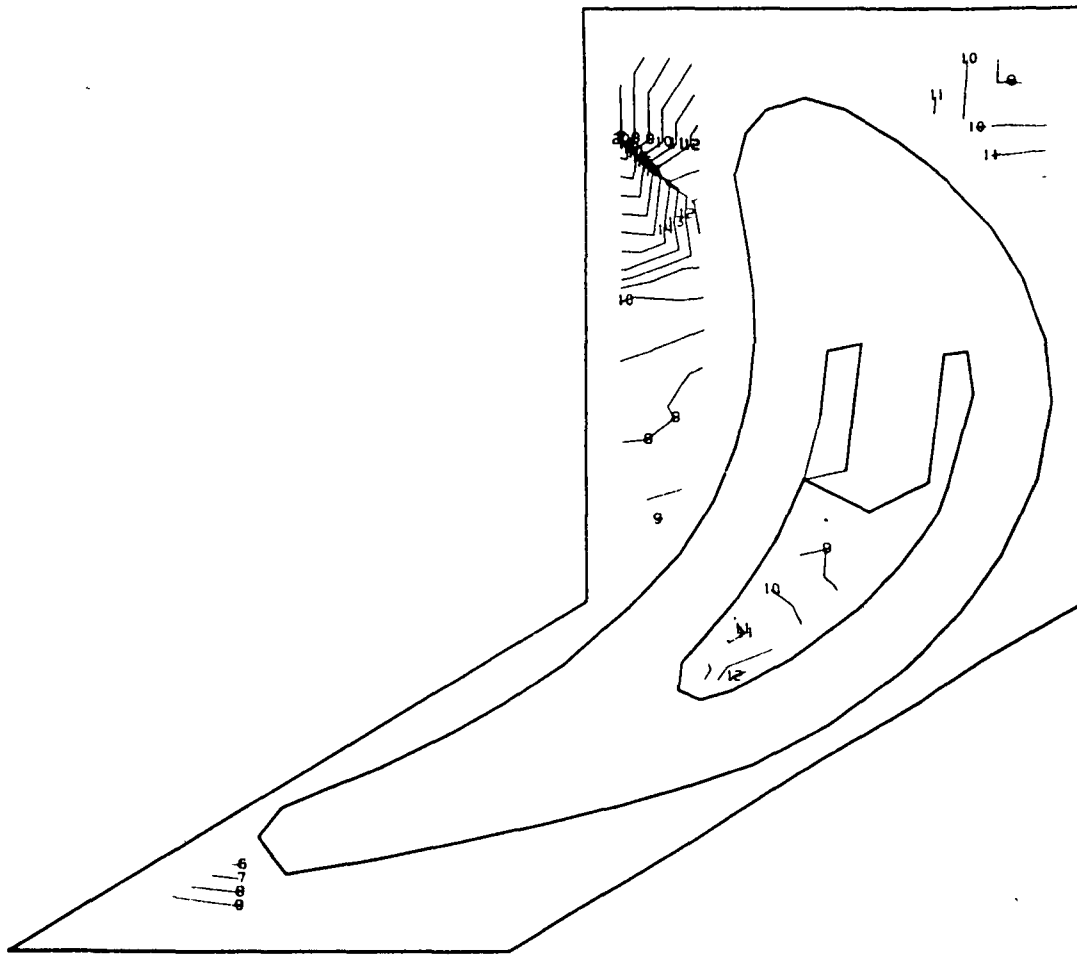

1	-1.274073E C5	11	3.440634E 04
2	-1.112259E C5	12	5.058769E 04
3	-9.504450E 04	13	6.676900E 04
4	-7.886313E C4	14	8.295031E 04
5	-6.268177E C4	15	9.913163E 04
6	-4.650042E C4	16	1.153129E 05
7	-3.031907E C4	17	1.314743E 05
8	-1.413772E C4	18	1.476756E C5
9	2.043633E C3	19	1.638569E 05
10	1.822498E C4	20	1.800385E C5

Fig. 3.5-33 Model 02, View 5, 115% Load, Major Principal Stress (psi)

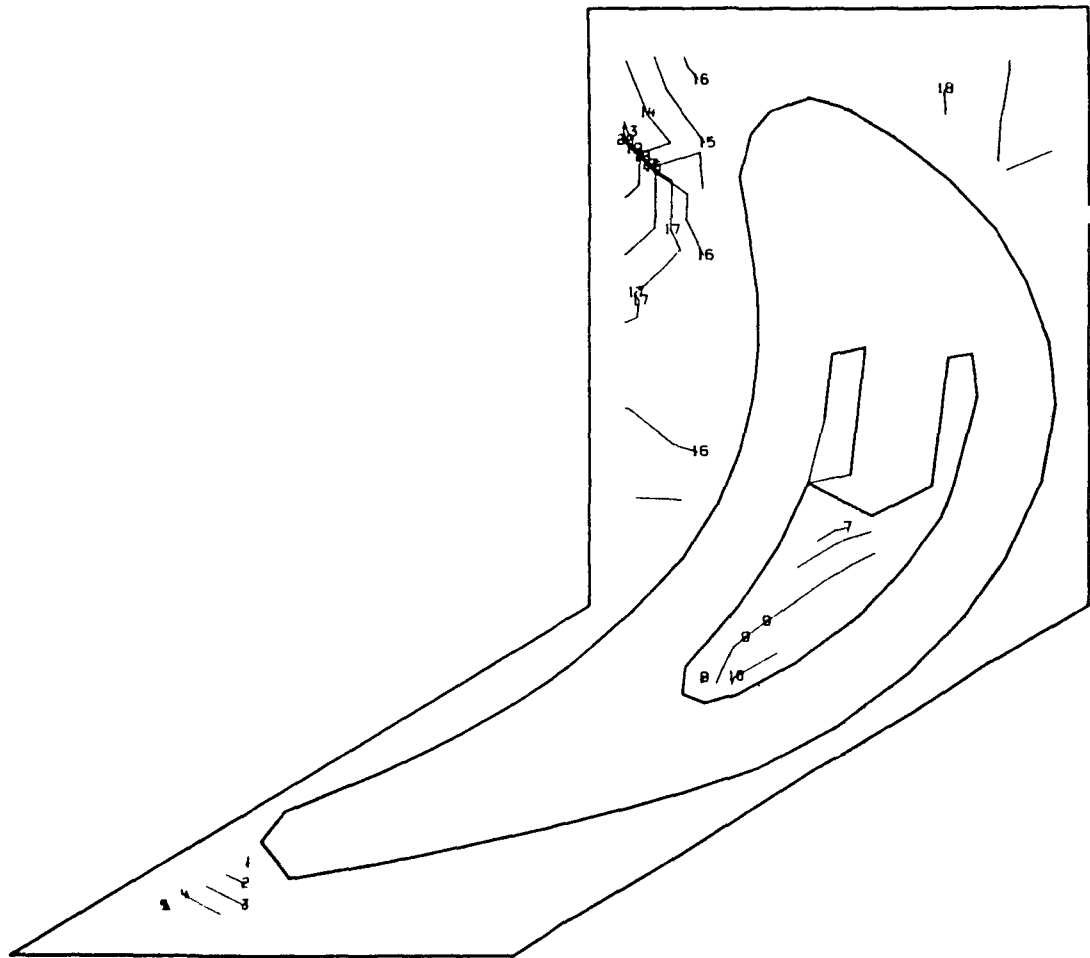

1	-3.904250E C5	11	-1.608244E 05
2	-2.674649E C5	12	-1.378643E 05
3	-3.445049E C5	13	-1.149043E 05
4	-3.215448E C5	14	-9.194419E 04
5	-2.985848E C5	15	-6.898413E 04
6	-2.756247E C5	16	-4.602409E 04
7	-2.526646E C5	17	-2.306405E 04
8	-2.297046E C5	18	-1.040073E 02
9	-2.067445E 05	19	2.285603E 04
10	-1.837844E C5	20	4.581575E 04

Fig. 3.5-34 Model 02, View 5, 115% Load, Minor Principal Stress (psi)

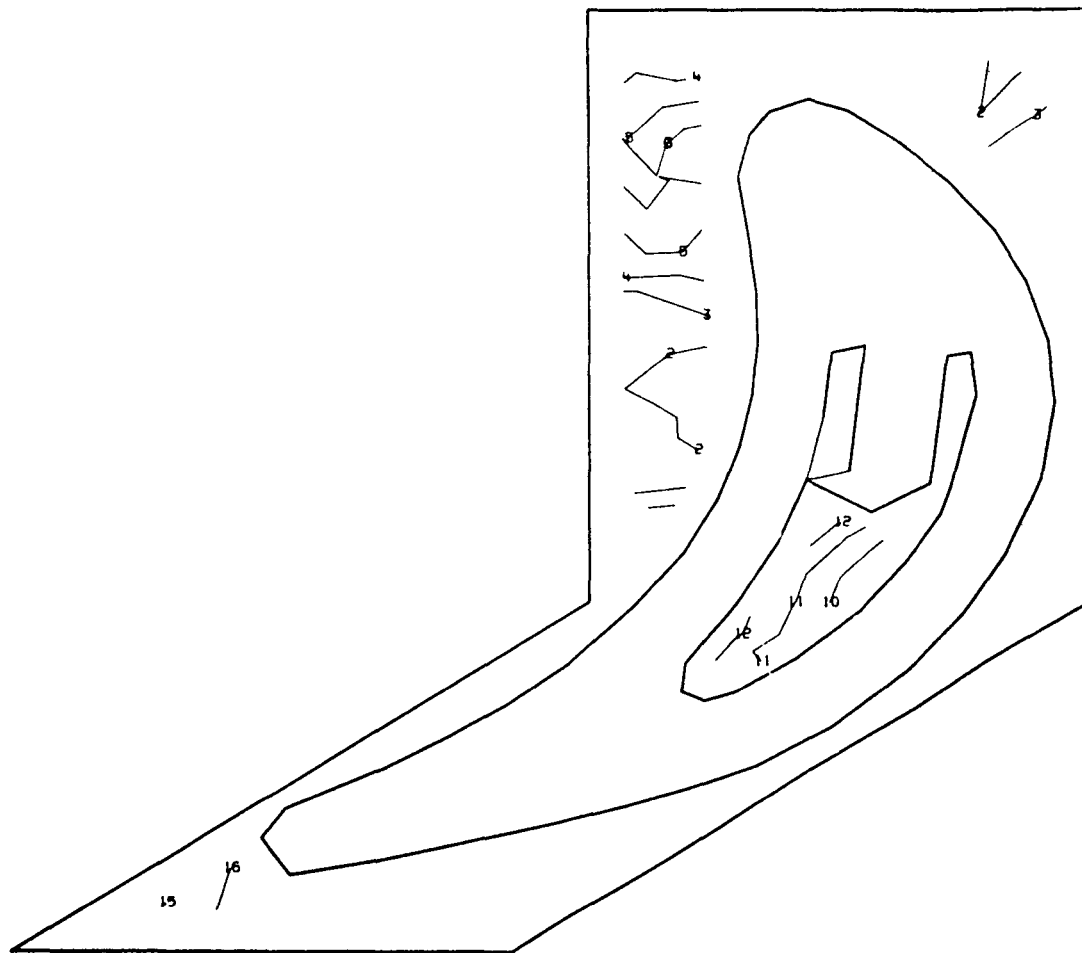

1	2.290597E C3	11	1.108101E 05
2	1.313355E C4	12	1.216630E 05
3	2.378651E C4	13	1.325159E 05
4	3.483946E C4	14	1.433689E 05
5	4.569242E C4	15	1.542218E 05
6	5.654538E C4	16	1.650748E 05
7	6.739831E C4	17	1.759277E 05
8	7.825125E C4	18	1.867806E 05
9	8.910419E C4	19	1.976336E 05
10	9.995713E C4	20	2.084869E 05

Fig. 3.5-35 Model 02, View 4, 115% Load, Shear Maximum Stress (psi)

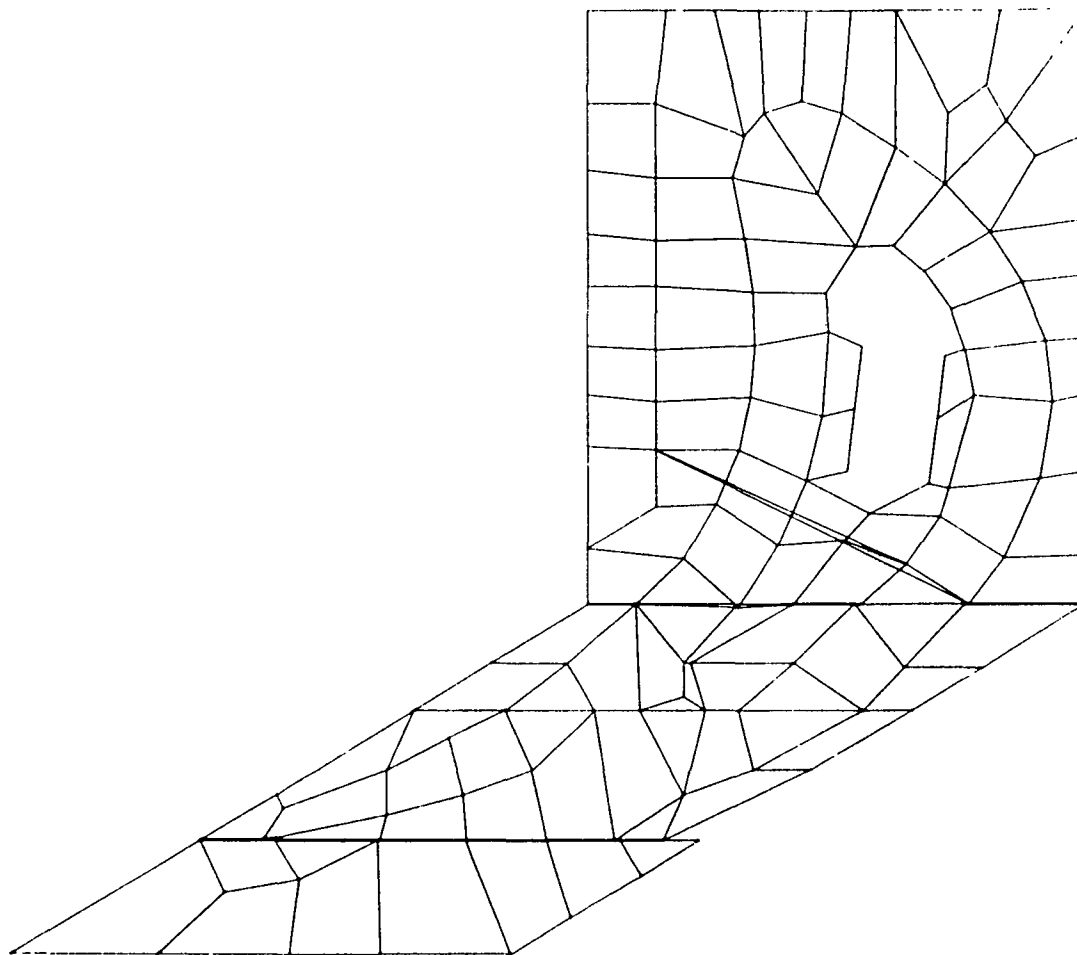
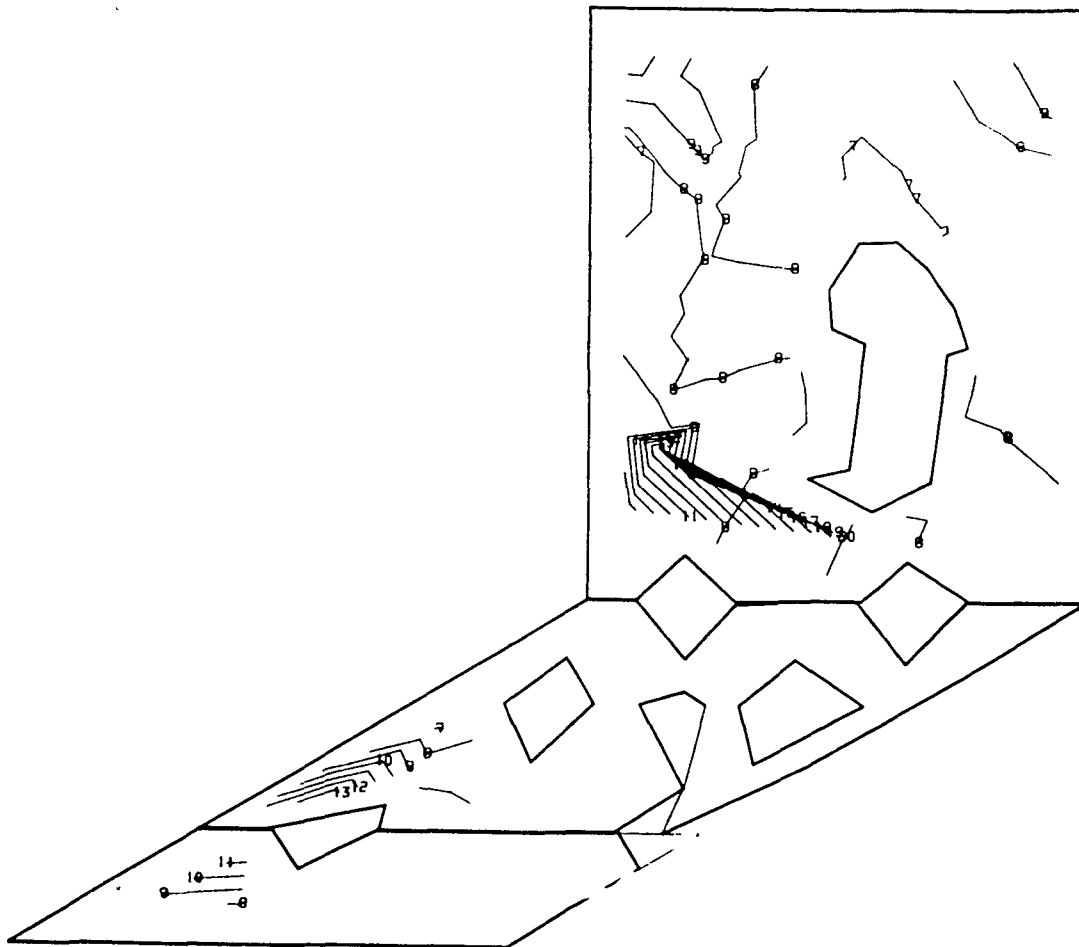
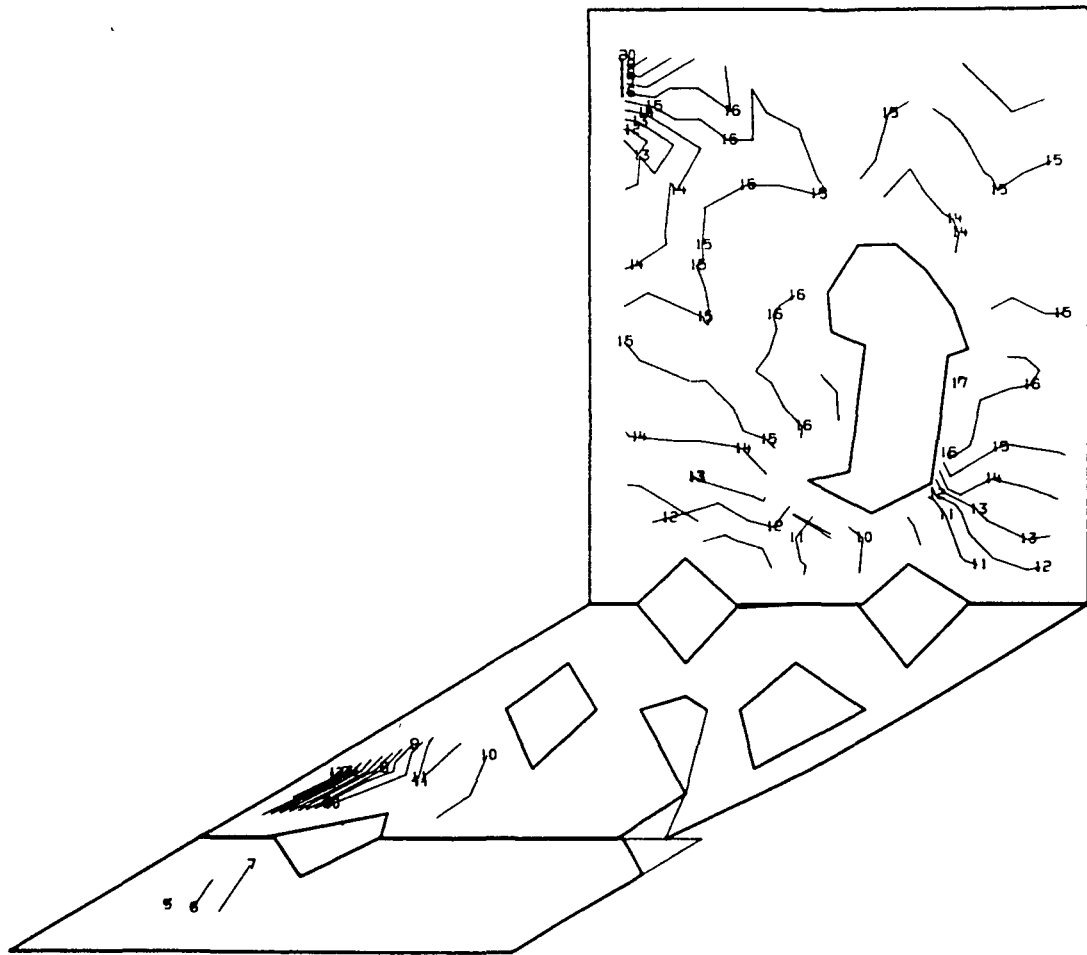

Fig. 3.5-36 Model 02, View 6, Hub Inside



1	-1.950986E C5	11	8.332819E 04
2	-1.672559E C5	12	1.111708E C5
3	-1.394133E C5	13	1.390134E 05
4	-1.115706E C5	14	1.668561E C5
5	-8.372788E C4	15	1.946987E C5
6	-5.588519E C4	16	2.225413E C5
7	-2.804251E C4	17	2.503839E C5
8	-1.998242E C2	18	2.782266E C5
9	2.764286E C4	19	3.060692E C5
10	5.548554E C4	20	3.335124E C5

Fig. 3.5-37 Model 02, View 6, FPL Load, Major Principal Stress (psi)



1	-2.519865E C5	11	-1.357665E C5
2	-2.303645E C5	12	-1.141445E C5
3	-3.087429E C5	13	-9.252250E C4
4	-2.871205E C5	14	-7.050050E C4
5	-2.654985E C5	15	-4.927854E C4
6	-2.438765E C5	16	-2.765658E C4
7	-2.222545E C5	17	-6.034617E C3
8	-2.006325E C5	18	1.558734E C4
9	-1.790105E C5	19	3.720930E C4
10	-1.573885E C5	20	5.883085E C4

Fig. 3.5-38 Model 02, View 6, FPL Load, Minor Principal Stress (psi)

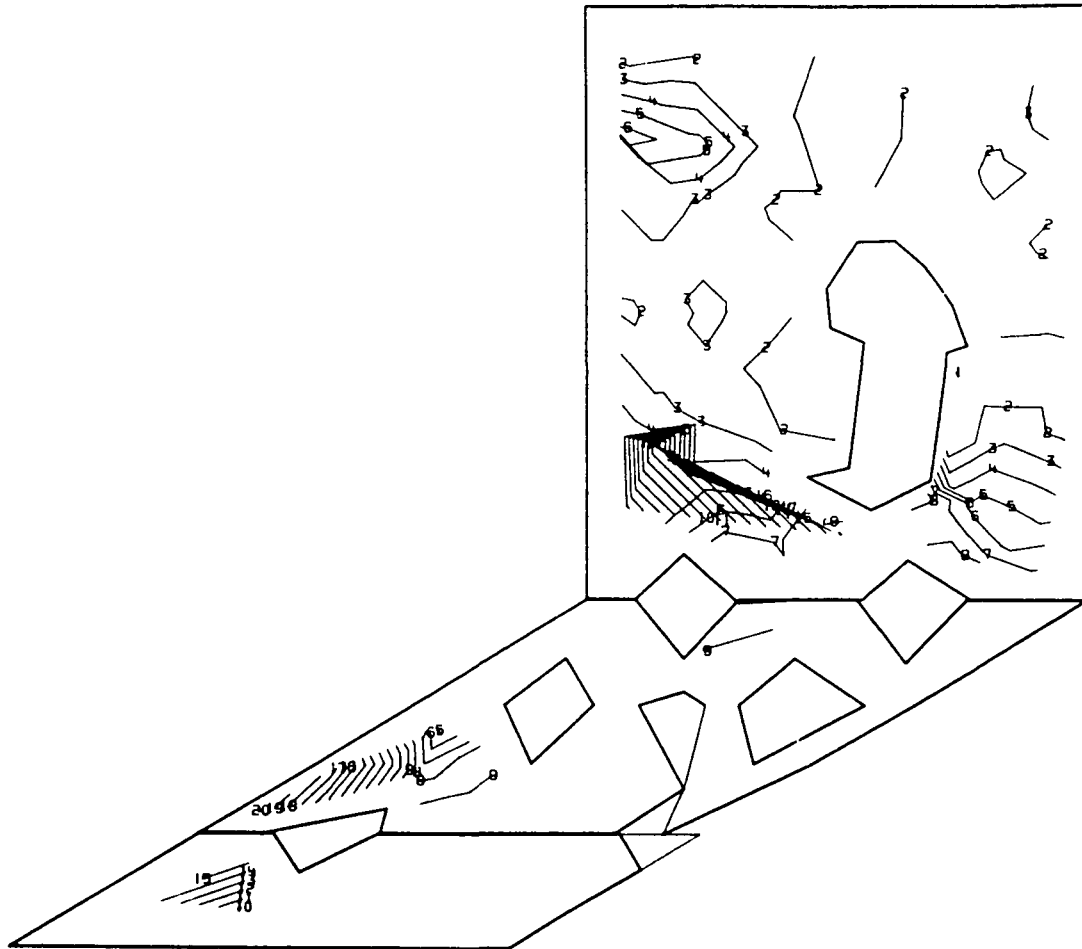

1	4.841633E C3	11	1.123306E C5
2	1.559054E C4	12	1.230794E C5
3	2.632945E C4	13	1.338283E C5
4	3.708836E C4	14	1.445772E C5
5	4.783727E C4	15	1.553261E C5
6	5.858618E C4	16	1.660749E C5
7	6.933506E C4	17	1.768238E C5
8	8.008394E C4	18	1.875727E C5
9	9.083281E C4	19	1.983216E C5
10	1.015817E C5	20	2.090705E C5

Fig. 3.5-39 Model 02, View 6, FPL Load, Shear Maximum Stress (psi)

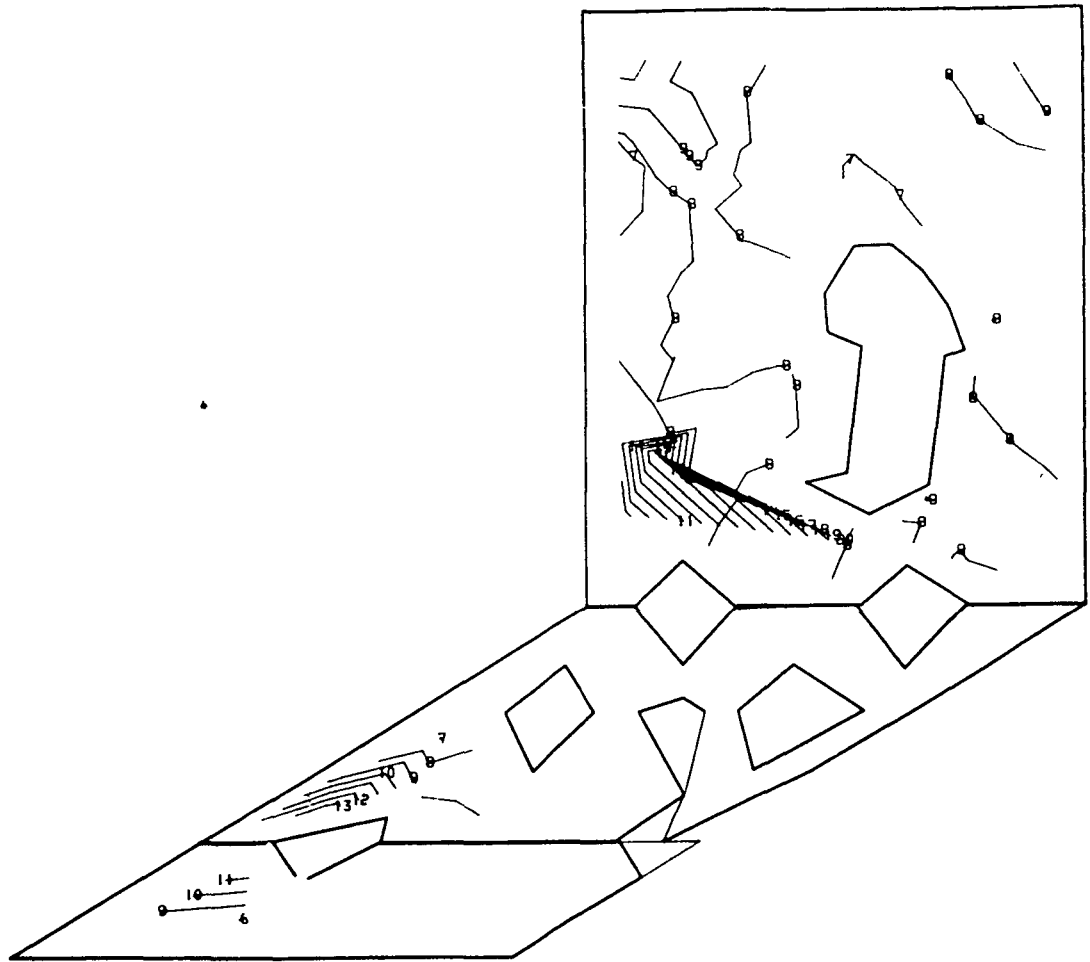

1	-2.293764E C5	11	9.647738E 04
2	-1.967910E C5	12	1.290628E 05
3	-1.642056E C5	13	1.616481E 05
4	-1.316203E C5	14	1.942335E 05
5	-9.903488F C4	15	2.268189E 05
6	-6.644950E C4	16	2.594043E 05
7	-3.386413E C4	17	2.919896E 05
8	-1.278750E C3	18	3.245750E 05
9	3.130663E C4	19	3.571604E 05
10	6.385200E C4	20	3.897458E 05

Fig. 3.5-40 Model 02, View 6, 115% Load, Major Principal Stress (psi)

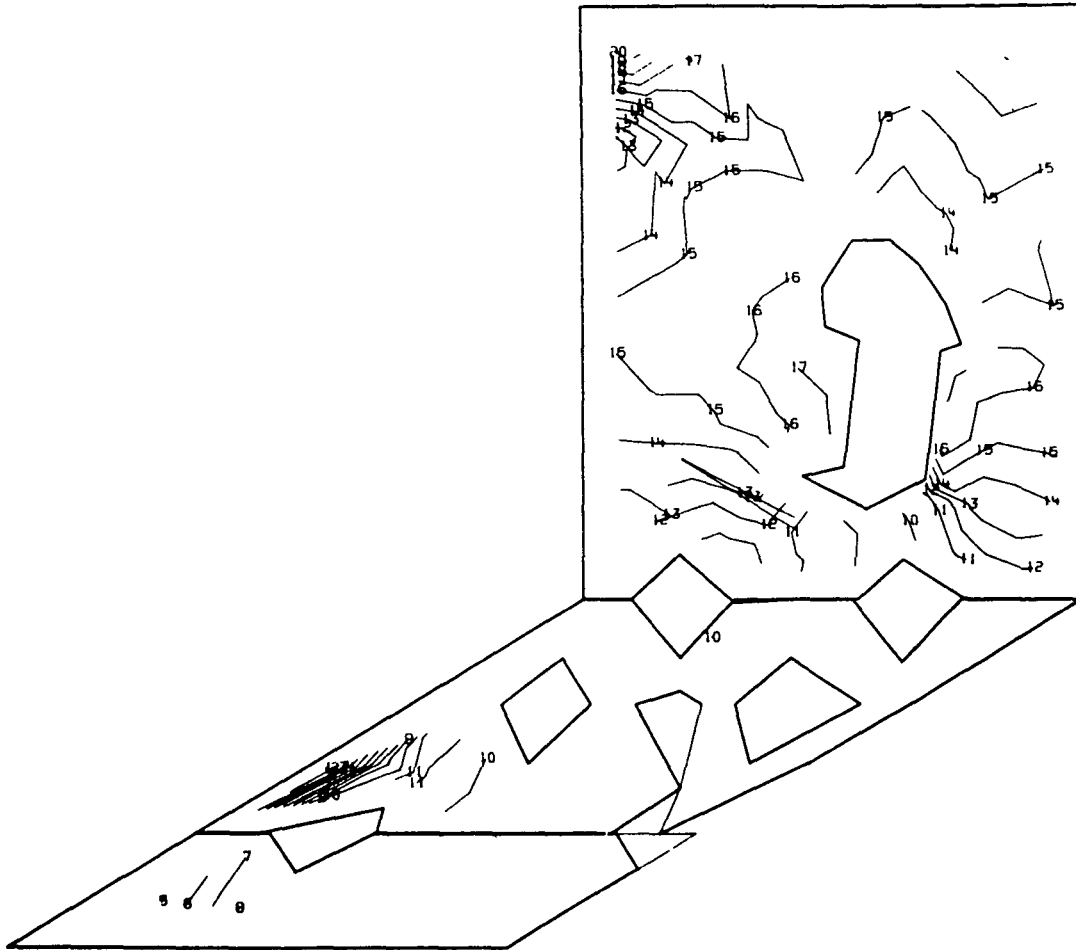

1	-4.146499E C5	11	-1.628631E 05
2	-3.894713E C5	12	-1.376844E 05
3	-3.642926E C5	13	-1.125057E 05
4	-2.391139E C5	14	-8.732700E 04
5	-3.139352E C5	15	-6.214932E 04
6	-2.887565E C5	16	-3.696963E 04
7	-2.635778E C5	17	-1.179095E 04
8	-2.383991E C5	18	1.338773E 04
9	-2.132204E C5	19	3.856642E 04
10	-1.880418E C5	20	6.374507E 04

Fig. 3.5-41 Model 02, View 6, 115% Load, Minor Principal Stress (psi)

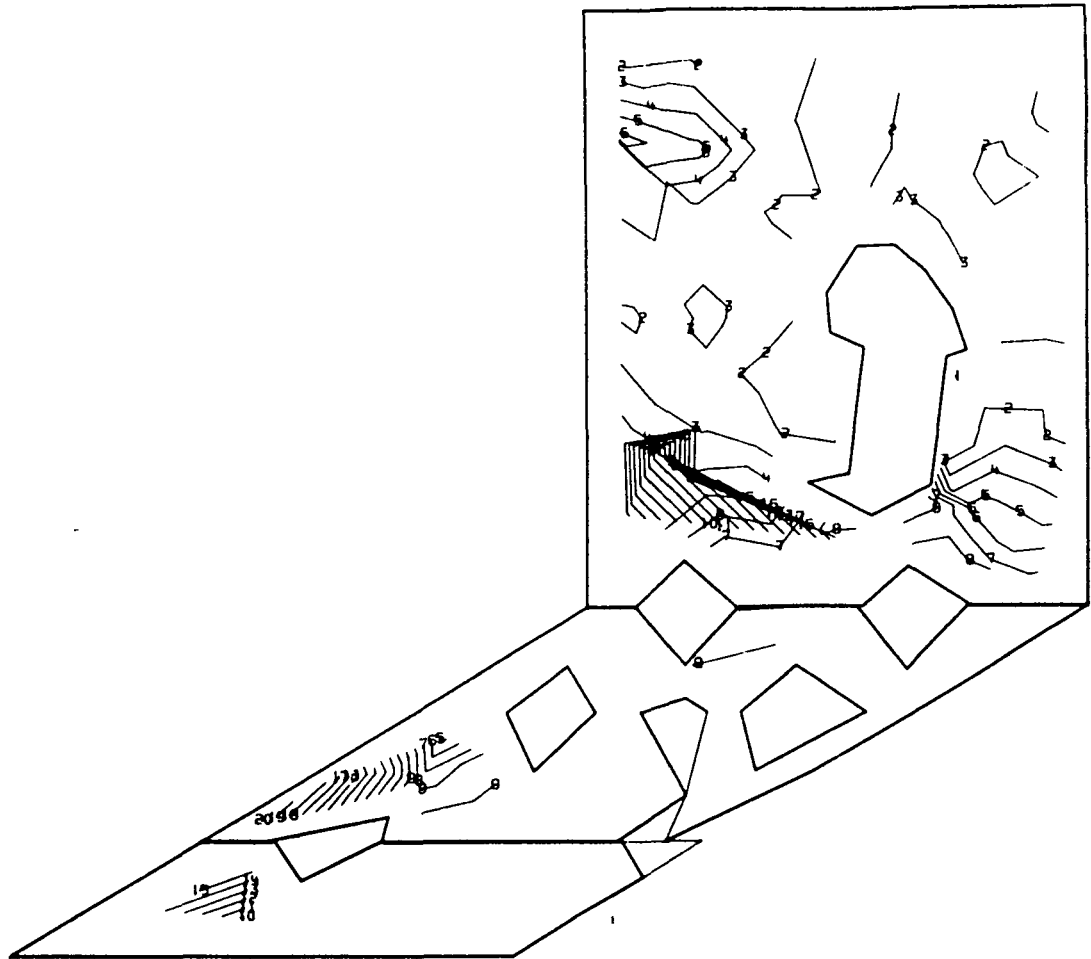

1	5.779754E C3	11	1.328199E 05
2	1.848379E C4	12	1.455239E 05
3	3.118783E C4	13	1.582279E 05
4	4.399187E C4	14	1.709319E 05
5	5.659591E C4	15	1.836359E 05
6	6.929994E C4	16	1.963399E 05
7	8.200394E C4	17	2.090439E 05
8	9.470794E C4	18	2.217479E 05
9	1.074119E C5	19	2.344519E 05
10	1.201159E C5	20	2.471566E 05

Fig. 3.5-42 Model 02, View 6, 115% Load, Shear Maximum Stress (psi)