

AIAA'87

AIAA-87-0293

DEVELOPMENT OF THE HELIUM SIGNATURE TEST FOR ORBITER MAIN PROPULSION SYSTEM REVALIDATION BETWEEN FLIGHTS

VINCENT J. BILARDO, JR. AND FRANCISCO IZQUIERDO, NATIONAL AERONAUTICS
AND SPACE ADMINISTRATION; R. KENNETH SMITH, ROCKWELL INTERNATIONAL,
KENNEDY SPACE CENTER, FL.

AIAA 25th Aerospace Sciences Meeting

January 12-15, 1987/Reno, Nevada

DEVELOPMENT OF THE HELIUM SIGNATURE TEST FOR ORBITER MAIN PROPULSION SYSTEM REVALIDATION BETWEEN FLIGHTS

Vincent J. Bilardo, Jr.* and Francisco Izquierdo**
National Aeronautics and Space Administration
Kennedy Space Center, FL
R. Kenneth Smith***
Rockwell International
Kennedy Space Center, FL

ABSTRACT

This paper presents the development of a test technique for revalidation of the Space Shuttle orbiter Main Propulsion System during ground turnaround operations between flights of the Space Transportation System (STS). The Main Propulsion System consists of the three Space Shuttle Main Engines (SSME's) and the Main Propulsion System (MPS) connecting the SSME's to the orbiter/ground and orbiter/External Tank (ET) interfaces. The Helium Signature Test (HST) performs an end-to-end leak check of the MPS/SSME subsystems that serves as a final validation of those systems for reuse. The test was initially developed during the ground processing flow prior to the STS-6 launch of orbiter Challenger. The test was developed to fulfill a requirement for an overall subsystem leak check as a result of experience gained during the STS-6 Challenger Flight Readiness Firing (FRF) series, during which leaks were encountered in the SSME's that were not detected by routine fluid joint leak checks. The HST technique is described in detail, including orbiter and test equipment configuration, and compared to other leak detection methods used to revalidate MPS/SSME systems for reuse. The HST data base accumulated since STS-6 is summarized and future test applications are described.

INTRODUCTION

The Space Shuttle orbiter Main Propulsion System uses liquid hydrogen and liquid oxygen for fuel and oxidizer. One of the earliest concerns associated with STS flights was minimizing potential leakage of these propellants from both cryogenic and high pressure (6000 psi gaseous hydrogen) systems so as to prevent the buildup of a flammable hydrogen mixture in the aft fuselage during ascent. Studies were performed to establish the ascent flammability limit and a significant effort was made to leak test these propellant systems prior to each of the first five flights of Columbia (OV-102).¹ The ability to limit ambient leakage to avoid ascent flammability conditions was considered to be of paramount importance. By the time the second shuttle vehicle, Challenger (OV-099), arrived at the Kennedy Space Center (KSC) for initial processing prior to the STS-6 mission, confidence had been gained that ground leak test procedures were assuring a non-flammable orbiter aft compartment environment during ascent.

*Lead Main Propulsion Systems Engineer
detailed to Vandenberg AFB, CA; AIAA
Member;

**Lead Main Engines Systems Engineer;

***Main Propulsion Systems Specialist;
AIAA Member

This paper is declared a work of the U.S. Government and is
not subject to copyright protection in the United States.

The Challenger Flight Readiness Firing (FRF), a static firing of the three SSME's at the KSC launch pad, on December 18, 1982 challenged that confidence when post firing data review revealed that MPS/SSME hydrogen gas leakage detected during the test was greater than 100,000 Standard Cubic Inches/Minute (scim). If launch had been attempted, the aft compartment flammability limit would have been exceeded. The STS-6 launch was postponed indefinitely until the leak source was located.⁵

This paper documents the development of a test technique, the Aft Compartment/MPS/SSME Helium Signature Test (HST), that was first used to help solve the pre-STIS-6 leakage problem, and then refined to an important pre-flight leak test.

NOMENCLATURE

DISC	Disconnect Valve
ET	External Tank
FRF	Flight Readiness Firing
GH ₂	Gaseous Hydrogen
GN ₂	Gaseous Nitrogen
GO ₂	Gaseous Oxygen
GSE	Ground Support Equipment
HGDS	Hazardous Gas Detection System
HST	Helium Signature Test
KSC	Kennedy Space Center
LC-39	Launch Complex 39
LCC	Launch Control Center
LH ₂	Liquid Hydrogen
LO ₂	Liquid Oxygen
MCC	Main Combustion Chamber
MECO	Main Engine Cutoff
MFV	Main Fuel Valve
MLP	Mobile Launcher Platform
MPS	Main Propulsion System
OPF	Orbiter Processing Facility
OV-099	Orbiter Vehicle Challenger
OV-102	Orbiter Vehicle Columbia
OV-103	Orbiter Vehicle Discovery
OV-104	Orbiter Vehicle Atlantis
PC	Purge Circuit
PPM	Parts Per Million
PSIA	Pounds Per Square Inch Absolute
PSIG	Pounds Per Square Inch Gage
PSID	Pounds Per Square Inch Differential
SCIM	Standard Cubic Inches Per Minute
SCFM	Standard Cubic Feet Per Minute
SRB	Solid Rocket Booster
SSME	Space Shuttle Main Engine
STS	Space Transportation System
TH	Test Hose
VAB	Vehicle Assembly Building

BACKGROUND

The Space Shuttle vehicle, shown in Figure 1, consists of the Shuttle Orbiter, the External Tank (ET), and two Solid Rocket Boosters (SRB's). During a nominal launch and ascent to orbit, the SRB's provide approximately 85% of the first stage thrust until they are jettisoned at 2 min. into the flight.

The SSME's, fed by the MPS with cryogenic propellants from the ET provide 100% of second stage thrust until Main Engine Cutoff (MECO) at approximately 8 minutes into the flight. Thus, nominal performance of the MPS and SSME's is essential to orbit attainment and subsequent completion of the mission.

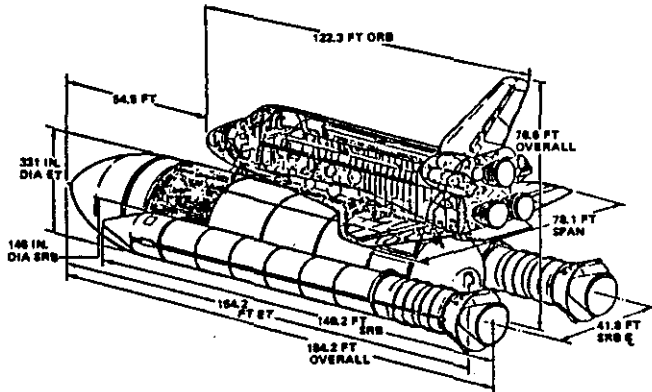

Figure 1. SPACE SHUTTLE VEHICLE

A nominal ground processing flow of the orbiter at KSC launch complex 39 consists of landing, tow into the Orbiter Processing Facility (OPF) where the majority of between-flight test, checkout, and revalidation operations occurs, rollover to the Vehicle Assembly Building (VAB) where the orbiter is rotated vertical and stacked to the waiting ET on a Mobile Launcher Platform (MLP), rollout to the launch pad, where final preflight operations are performed, countdown and launch.²

Main Propulsion System

The Main Propulsion System is shown in Figure 2. Located in the orbiter aft compartment, the MPS controls the flow of cryogenic propellants, purge and pressurant gases to and from the SSME's. Specifically, the MPS consists of the following subsystems: liquid hydrogen propellant feed, (fill and drain, bleed, and recirculation lines), liquid oxygen propellant feed, (fill and drain, bleed, and pogo suppression lines), gaseous hydrogen (GH₂ ET pressurization) system, and gaseous oxygen (GO₂ ET pressurization) system. The orbiter portions of these systems downstream of the orbiter/ET and orbiter/ground interfaces are individually leak tested during the HST. The MPS also contains gaseous helium and nitrogen pneumatic systems which provide pressurization and purge gas for MPS/SSME operation and conditioning. A simplified propellant flow schematic with nominal operating pressures and temperatures is shown in Figure 3.³

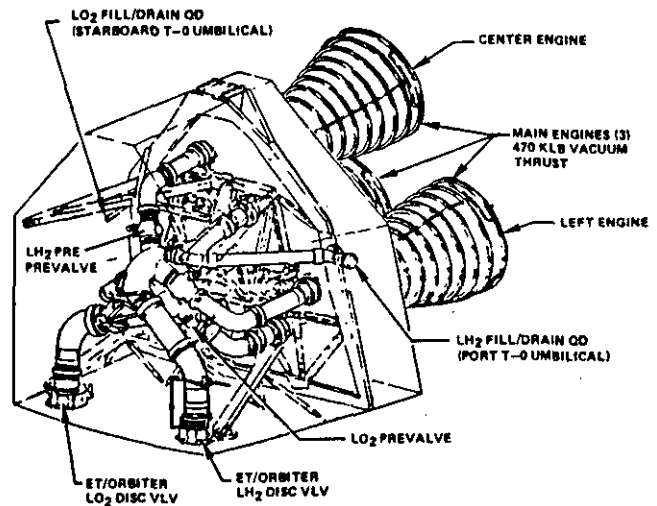

Figure 2. MAIN PROPULSION SYSTEM INSTALLATION

Purge, Vent & Drain System

The purge, vent, and drain system provides the unpressurized compartments of the orbiter with either a nitrogen or air purge that thermally conditions system components and prevents hazardous gas accumulation. This system also vents compartments during ascent and takes in air during descent to minimize differential pressures.

The purge system carries conditioned gas from ground support equipment (GSE) to the orbiter cavities via the starboard aft umbilical during preflight and postflight operations. Purge gas is provided to three separate sets of distribution plumbing: (1) the forward fuselage, wings, and vertical stabilizer, (2) mid fuselage, and (3) the aft fuselage.¹⁰

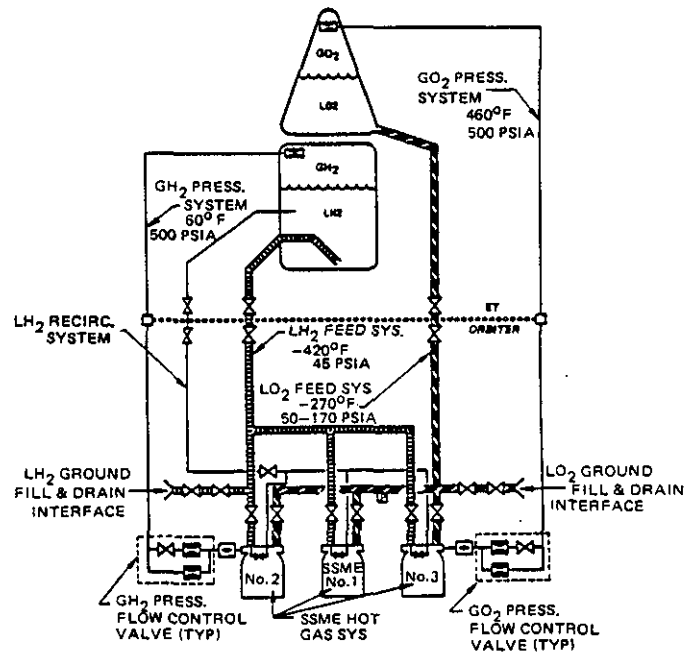

Figure 3. MAIN PROPULSION SYSTEM SCHEMATIC

Space Shuttle Main Engine

The SSME is a reusable, variable thrust, cryogenic hydrogen/oxygen engine that represents the state of the art operational liquid rocket propulsion technology. The SSME, shown schematically in Figure 4, utilizes a two stage power cycle in which propellants are partially combusted at relatively low temperature in two preburners, drive two propellant turbo-pumps, then are fully combusted at high temperature and pressure in the Main Combustion Chamber (MCC) before being expanded through a 77:1 area ratio nozzle. The SSME operates at a 6:1 LO₂/LH₂ mass flow mixture and is capable of variable performance from 65 to 104 percent of a rated 375,000 lbf sea level thrust. Nominal operating conditions at the 100% thrust level are shown in Figure 4. The LH₂, LO₂, and hot gas portions of the SSME are leak tested in conjunction with the appropriate MPS subsystems during the HST.⁴

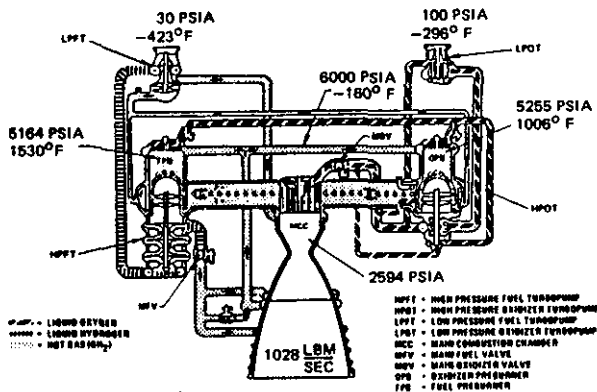

Figure 4. SPACE SHUTTLE MAIN ENGINE SCHEMATIC

Test History

During the initial OV-099 FRF, operation of all orbiter systems was nominal and functionally the test was considered a success. Immediately following engine shutdown, however, the concentration of hydrogen gas in the aft fuselage reached an unexpectedly high value (4600 PPM). Subsequent data review and analysis indicated the peak hydrogen concentrations may have been considerably higher. The source of the hydrogen had to be isolated and corrected before the orbiter could be committed to flight.

Initial troubleshooting to isolate the source of the leak considered two possibilities: (1) an actual leak external to an MPS/SSME subsystem leaking into the aft fuselage or (2) ingestion of hydrogen from outside the vehicle driven by SSME startup and/or shutdown transients. However, neither hypothesis could be confirmed after an extensive review of the existing test data. Concurrent with the data review ground test personnel performed leak tests of all MPS & SSME fluid connections using mass spectrometer hand held probe techniques. Despite intensive around-the-clock efforts, no significant leakage could be found. As a result, a decision was made to conduct a second FRF with sufficient additional instrumentation to allow isolation of the hydrogen leakage source. A second FRF was performed on January 25, 1983 and the previous leakage results were confirmed. The leakage source was internal to the aft fuselage and must be found prior to launch.⁵

At this point it became obvious that a new leak test concept was needed to isolate and find the leak source(s). A test was devised that would allow direct measurement of any MPS/SSME subsystem external leakage into the aft compartment by means of purge air transport of that leakage to a single gas concentration measurement point. In this way, a "signature" of helium test gas leakage into the aft compartment would be obtained. A similar leak test method had been utilized for the orbiter aft umbilical cryogenic interface connections.¹¹

As the planning and preparation for this signature test continued, a new search of the aft fuselage for leakage found a leak source on SSME #1 MCC. Flowmeter leak tests indicated a leakage of ~425 scim at ~40 psig. However, analytical extrapolation of this ambient leakage to the SSME firing conditions showed that an additional leak source had to be present to account for all the aft fuselage hydrogen concentrations. The helium signature test (HST) indicated that the SSME #1 leak was ~360 scim, but also revealed that SSME #2 had an additional leakage of 25 scim. This test was also performed at ~40 psig. After still more leak tests this leakage source was also isolated. These SSME's were subsequently replaced and the STS-6 mission successfully flown. As a result of this experience, the HST was refined and immediately implemented as a final MPS revalidation test prior to each subsequent STS flight.

LEAK DETECTION THEORY

Ascent Leak Detection

Figure 8 shows theoretical aft fuselage hydrogen concentration as a function of aft fuselage pressure for the ascent phase of an STS flight.⁸ The curve marked flammability limit depicts 4% by volume hydrogen-in-air mixture; 4% is widely accepted as the flammability limit for H₂ in air.¹ Thus accumulation of hydrogen in the aft, composed of both external leakage from the MPS and ingestion of the hydrogen-rich SSME plume must be less than this limit to assure safe Shuttle flight operation. Ascent hydrogen concentrations are currently measured by six pyro-initiated, evacuated gas sample bottles that are mounted near the port and starboard vent doors. These bottles provide discrete gas samples at selected times during the boost phase. The bottles are analyzed post-flight for hydrogen and oxygen content. Data from STS-1 thru -4 are presented in Figure 8. These results are typical of all Shuttle flights.

Propellant Loading Leak Detection

During pre-launch propellant loading the HGDS samples the effluent purge gas exiting both port and starboard vent doors and provides real time gas concentrations to launch controllers in the LCC. Thus the HGDS provides a means of determining the leakage of those systems exposed to cryogenic conditions prior to liftoff. These systems include the LO₂ and LH₂ MPS/SSME propellant feed systems defined previously. However, only 1% of the pre-flight leakage has the potential of being from high pressure leak paths since 61% of the fluid joints that are exposed to up to 6000 psi in flight do not see any hydrogen during propellant loading prior to SSME ignition. Thus, leak testing of this portion of the hot gas system must be completed during ambient conditions prior to cryogenic loading.

Ambient Leak Detection

Table 1 lists the sensitivities of various methods of ambient leak testing utilized on the MPS/SSME systems. Prior to the STS-6 FRF only point-to-point leak tests were performed. These checks were performed at mechanical, i.e. threaded or flanged connections, and metallurgical, i.e. welded or brazed, joints only, ignoring defects that might occur in the component parent metal.

TABLE 1
SENSITIVITY OF EXTERNAL LEAK DETECTION METHODS USED DURING MPS REVALIDATION BETWEEN FLIGHTS

AMBIENT EXTERNAL LEAK TEST METHOD	MINIMUM DETECTABLE LEAK (SCIM) ⁹
SOAP SOLUTION	10 (-3)
MASS SPEC PROBE	10 (-7)
VOLUMETRIC FLOW RATE	0.3
PRESSURE DECAY	.
HELIUM SIGNATURE	6

⁹PRIMARILY AN INTERNAL LEAK TEST, I.E. FOR COMPONENT LEAKAGE FROM SEALS, CHECK AND RELIEF VALVES, ETC. BEST CASE SENSITIVITY = ~100 SCIM.

Helium is used as a test gas because of its inert characteristics. Leak testing with hydrogen would cause undue safety hazards for personnel. Since the density ratio of helium to hydrogen is 2:1 at ambient temperatures, leak testing with helium most closely approximates an ambient hydrogen leakage rate.

Whenever design provisions allow, flanged connections are checked by using a flowmeter. Threaded, brazed and welded connections are checked by either the soap solution technique or a mass spectrometer probing technique. A soap solution test is performed by applying a thin film of high surface tension fluid onto the internally pressurized joint and visually inspecting for bubble formation indicative of a leak. Mass spectrometer probe tests are performed by slowly transverseing a probe connected to a helium mass spectrometer leak detector around the circumference of the test joint. A helium leakage is identified as a positive increase above the ambient helium background.

Unlike the previously mentioned techniques, the pressure decay test method provides a quantitative leak test of the total pressurized volume. However, the sensitivity of this method is severely limited by the internal leakage characteristics of MPS/SSME components (i.e., shutoff valves, check valves, etc.). Many of these components have allowable leakage limits that exceed the allowable system external leakage limits. In addition, these internal leakages are often variable with time and mechanism cycles so that the pressure decay test method provides only a gross indication of system integrity.

Each of the above leak detection techniques was used to revalidate the orbiter MPS between flights. The pressure decay test was the only system level test performed prior to development of the HST. The HST has the advantage of measuring only external leakage and also allows the entire SSME hot gas system to be tested, which is not practical with a pressure decay test.

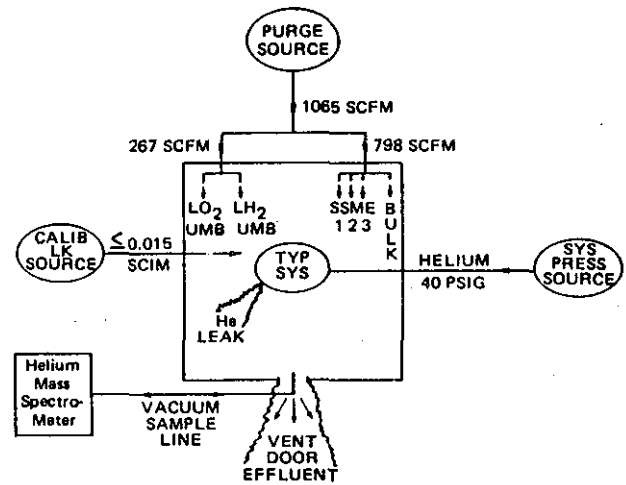

Figure 5. SCHEMATIC OF HELIUM SIGNATURE TEST SETUP

A schematic of the HST setup is shown in Figure 5. The orbiter aft compartment forms a control volume of approximately 4500 cubic ft. containing the MPS/SSME subsystems which are to be tested for external leaks. Each of these subsystems is connected to a helium pressurization source capable of providing 40 psig for the propellant and SSME hot gas subsystems and 400 psig for the pressurization subsystems. Once pressurized, any external leakage from a given subsystem mixes with the aft compartment air purge and is convected out a single opening. This effluent gas stream is sampled for helium concentration through a sample line connected to a helium mass spectrometer leak detector. Helium concentration is then converted to an equivalent volumetric leakage rate using a calibration relationship determined by injection of a known helium flowrate into the aft compartment.

TEST TECHNIQUE

Test Setup

A diagram of the test setup used during Orbiter checkout is shown in Figure 6. The liquid hydrogen propellant feed subsystem is shown, including the SSME hot gas systems. MPS subsystem pressurization sources (not shown) are connected through both Orbiter/ground aft umbilicals (LH2/GH2 through the port umbilical; LO2/GO2 through the

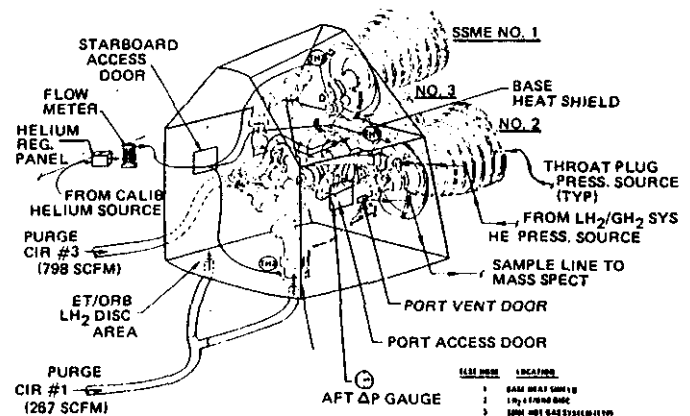

Figure 6. AFT COMPARTMENT HELIUM SIGNATURE TEST SETUP

starboard umbilical). Also, the SSME hot gas systems are pressurized through a "throat plug" which seals off the main combustion chamber upstream of the nozzle throat.

This test can be run while the vehicle is horizontal in the OPF or vertical at the launch pad. When the test is run in the OPF, a portable mass spectrometer is used. When the test is run at the launch pad, a permanently installed multiple gas analyzer is used which is part of an integrated vehicle/ground Hazardous Gas Detection System (HGDS). A schematic of this unit is shown in Figure 7. The HGDS is designed to measure the concentration of hazardous gases within the Space Shuttle vehicle during propellant loading, and provide a real-time readout to launch controllers in the LC-39 Launch Control Center (LCC).

The HGDS interfaces with the vehicle aft compartment through a quick disconnect fluid coupling located in the port aft umbilical. The sample line is permanently installed in the orbiter and leads to both port and starboard aft vent doors. The flight vehicle vent door assembly consists of four honeycomb screens that allow flow into a plenum-like cavity where the sampling port is located. The inlet screens increase the mixing of the flowstreams and reduce stratification effects. The sample port is located in a static area of the plenum. The starboard sample port is plugged during the HST because that vent door is closed throughout the test.

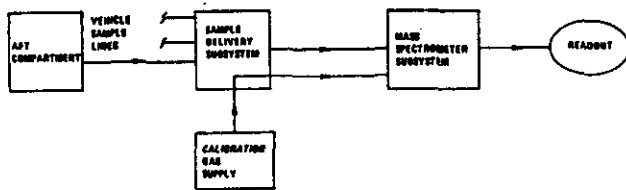

Figure 7. GROUND HAZARDOUS GAS DETECTION SYSTEM (HGDS) SCHEMATIC

Test Operation

The HST test sequence consists of: (1) pre-test setup, (2) helium calibration runs, (3) subsystem pressurization runs, (4) post-test calibration runs, and (5) post test securing of setup and equipment.

Pre-test setup is extensive, requiring installation of all ground support equipment (GSE) shown in Figure 6. Other equipment not shown includes a throttling fixture external to the port vent door that allows control of the aft compartment pressure differential to 0.5-0.9 inches of water (0.018 - 0.032 PSID). A differential pressure gage provides a continuous check of aft compartment sealing. This sealing is critical to maximize the purge effluent that exits through the port vent door.

Prior to start of calibration, the aft compartment background helium concentration is measured to establish a baseline concentration. Helium is then injected into the aft through Test Hose 1 (TH 1), initially at 6 scim. Helium concentration is monitored for a minimum of 30 minutes until a steady-state concentration is achieved. The background value measured at test start is then subtracted from this steady-state value, resulting in a concentration difference which is plotted against the 6 scim injected

flowrate. Helium flowrate is then increased to 15 scim and the above process repeated to obtain a second calibration point. A final value is obtained for 25 scim injected flowrate.

The resulting calibration relationship is then checked for linearity with respect to the origin and, if satisfactory, the helium injection is terminated for TH 1. The helium concentration is then allowed to return to a steady background level. The calibration process is repeated for other points in the aft compartment. Note that the injection flowrates of 6, 15, and 25 scim were determined based on an analysis of the minimum leak rate measurable with the mass spectrometers available at KSC. This value was predicted to be 6 scim.

Uncertainty is calculated using a procedure which accounts for uncertainties in the concentration and flowrate measurements and instrument drift with time in the mass spectrometer. The uncertainty in leak rate for the current test equipment and configuration has averaged ± 3 scim.^{6,7}

Following completion of the calibration sequence, each MPS subsystem is pressurized and leak tested individually. The procedure is the same as used during the calibration run, except that the delta helium concentration is used to obtain an equivalent leak rate from the calibration relationship. If the sum of corrected leakage value and its upper range uncertainty exceeds 12 scim, the subsystem in question is considered out of specification, and isolation of the indicated leak source begins. In this way, the HST provides an overall subsystem level verification of propellant system integrity after all preceding point-to-point leak checks are complete.

Following completion of subsystem pressurization runs, a post-test calibration run is performed to verify that test setup configuration and instrumentation integrity has been maintained throughout the test.

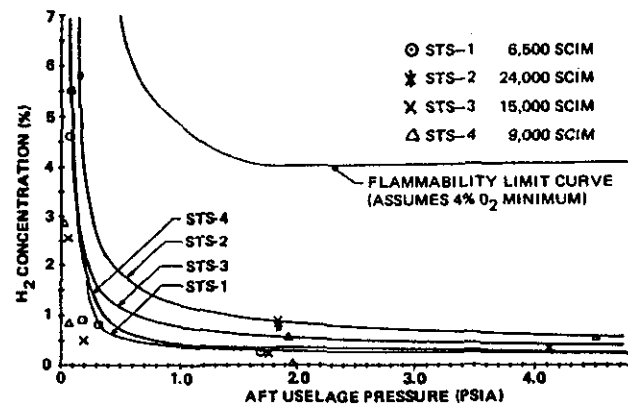

Figure 8. IN-FLIGHT GAS SAMPLE BOTTLE RESULTS (STS-1 thru 4)⁸

RESULTS AND DISCUSSION

Calibration Results

The HST sensitivity and gas sampling system efficiency were measured by injecting helium at various locations in the aft fuselage during calibration runs. Results of this calibration are presented in Figure 9 for OV-103. The results are typical of all orbiter vehicles in a vertical orientation. The ideal mixing line is obtained from the following equation:

$$C = \frac{(Q_{Leak}) \times 10}{(Q_{Purge})} \quad (1)$$

where C is helium concentration in PPM, Q Leak is the simulated volumetric helium leak rate in scfm and Q Purge is the volumetric aft compartment air flow rate in scfm. Ideal mixing occurs if the injected helium is completely mixed with purge air and transported out the single open aft compartment vent door. In reality, this line can only be approached because of (1) incomplete mixing of helium leakage with purge air, and (2) incomplete sealing of the aft compartment. As Figure 9 indicates, leaks injected in regions of high air purge velocities, such as TH 1 near the purge circuit (PC) #3 bulk exit and near each SSME hot gas system, best approximate the ideal mixing concentration.

TH 1 results have been consistent and repeatable from orbiter to orbiter, and best approximate ideal mixing of any aft compartment injection location. Thus, TH 1 results have always been used to determine the calibration relationship for subsequent subsystem pressurization runs.

One propellant loading and ambient leak detection limitation is the relative inability to detect the exact location of a leak in the particular subsystem under test. Since leaking helium is transported to the aft fuselage vent door sample port by means of both molecular diffusion and forced convection, the superposition of these two mechanisms along with the complex geometry of the MPS installation render an analytical prediction of helium distribution impossible. For this reason, leakage has been simulated at other locations in the aft fuselage.

These simulated leakages at other points in the aft fuselage are also shown in Figure 9. The simulated leak at the GH2 flow control valve location is detected as ~200% of the ideal value. The GH2 flow control valves are located approximately 5 feet from the sample port location. This indicates that a leak near the vent door sample port is entrained by the effluent gas stream exiting the vent door before completely mixing in the aft fuselage for reasonable test durations. Fortunately, most of the potential leak sources are located sufficiently distant from the vent door to allow adequate mixing with the aft fuselage purge.

Leakage was also simulated from the LH2 ET/Orbiter disconnect area when the orbiter was in a vertical orientation. This leakage produced concentrations less than 10% of ideal without auxiliary purge air directed to the area. This demonstrates inadequate mixing in these areas and can be explained by the fact that (1) this part of the aft fuselage has significant structural leakage, (2) buoyancy effects allow helium to rise to the top of the aft fuselage from injection locations where forced convection effects are negligible. This problem has been solved by providing a dedicated purge of 134 scfm to each disconnect area to force this leakage to the vent door. Figure 9 shows the effect that an intermediate purge value of 53 scfm produced at the LH2 umbilical in the vertical attitude.

Although not shown in Figure 9, prior to incorporating the auxiliary purge in the horizontal test configuration, leakage detected from the LO2/LH2 ET umbilical area was approximately 40% of theoretical. With the use of 134 scfm purge into each of the umbilical areas, the resulting helium

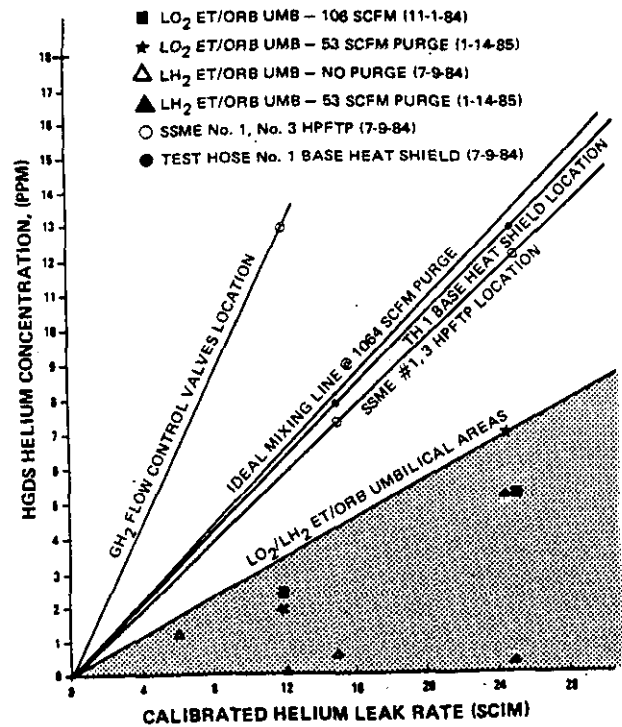

Figure 9. OV-103 SIGNATURE TEST SIMULATED LEAKAGE CALIBRATION FOR VERTICAL POSITION AT PAD

concentration approaches 100% of ideal for leak sources close to the purge exit.

Although these results demonstrate the value of locally enhanced mixing it is not practical to provide a special purge to every stagnant area. Since tests have shown that simulated leakage at other leak locations result in concentrations of approximately 75% of ideal, a correction factor of 1.25 has been chosen to account for these differences. This correction factor is applied to the leakage reading obtained during subsystem pressurization run based on the TH 1 calibration curve. This is a conservative approach since a majority of the most critical potential leak locations are in areas aft of the PC #3 bulk air purge exit plane where mixing is maximized.

Subsystem Pressurization Results

Following the STS-6 OV-099 experience the development of the helium signature test method received a high priority in the Shuttle program. Several improvements in system sensitivity, measurement technique, data analysis and purge distribution were gradually incorporated to enhance the reliability of the test. Because of these changes, HST accuracy is now estimated to be ± 3 scim when leakage is in the 0 to 25 scim range.

However, the LH2 feed system leakage measured prior to OV-103 Flight #3 is an example which demonstrates that in some instances, system accuracy is much better than ± 3 scim. Prior to this flight, the HST indicated a leakage of 13 scim at 40 psig. After the leak source was discovered a flowmeter leak test was performed resulting in an measured leakage of 12 scim at 40 psig. The only other leak that has been found above the 12 scim allowable limit was located on an SSME MFV flange. The signature test for OV-099 Flight #2 identified this leakage to be 75 scim at 40 psig. Neither of these leaks were found during point-to-point leak testing. Both of these leaks were repaired prior to propellant loading.

The results of the HST subsystem pressurization runs, averaged over all HST runs to date, are presented in Figure 10 for each orbiter. Note that the two out-of-tolerance leaks mentioned above are not reflected in these values. The retest leakage from the HST run after the leaks were repaired has been incorporated. Generally, ambient leakage from any system is primarily affected by component removal and replacement frequency. The largest number of component changeouts occurs in the hot gas system. These systems display the highest average leakage for each orbiter, with the exception of OV-103, which has a larger GO₂ pressurization system leakage. This can be accounted for by a known, acceptable leak of approximately 2 scim from a flange located near the LO₂ ET/orbiter umbilical. The composite leakage for each system in each orbiter is well below the maximum allowable 12 scim limit. This demonstrates a conservative margin of test technique sensitivity and constitutes an extensive data base of acceptable ambient test leakage levels prior to confirmed safe and successful MPS/SSME operation during ascent.

One of the critical ground testing limitations is an inability to approach flight operating pressures during leak test. Specifically, the main combustion chamber throat plug design does not allow pressurization of the SSME hot gas system above 40 psig. However, portions of this system operate at 6000 psia during ascent. Figure 11 shows the relationship between helium leakage at leak test conditions (55 psia, 70° F) and the equivalent gaseous hydrogen leakage at flight operating pressure and temperature. This analysis assumes that a typical leak can be modeled as a choked orifice of constant area and discharge coefficient. The line shown is for a hypothetical leak in the SSME hot gas system at worst case conditions, i.e. GH₂ AT 6000 psia, -160° F.

A comparison of predicted leakage and actual ascent gas sample bottle data is shown in Figure 12 for OV-099 and Figure 13 for OV-103. Due to the limited HST data base for OV-102 and OV-104 this comparison is not shown for those vehicles. Note that the flight data are of the same order of magnitude as the values predicted with the constant area/discharge coefficient orifice analysis. This constitutes good agreement if the following factors are considered. First, the net uncertainty in gas sample bottle leak rate is estimated to be approximately ±1000 scim. Second, a fraction of the OV-099 and OV-103 ascent leakage is caused by LH₂ feed system leak sources rather than hot gas system leaks. This can be seen in Tables 2 and 3 which presents OV-099 and OV-103 LH₂ system leakage at ambient test (helium) and cryogenic (LH₂ at 40-55 psig, -420° F) conditions. The average cryogenic leakage for all flights shown is 1370 scim for OV-099 and 1150 scim for OV-103. These values are obtained using Eq. 1 for actual HDGS aft compartment hydrogen concentrations during prelift-off propellant loading. These leak rates may increase during ascent due to higher LH₂ system operating pressures in the SSME. Third, the constant area-discharge coefficient assumption produces the minimum predicted leakage. Actual leak areas may vary as an indeterminable function of flight pressure, temperature or vibration. Since neither this function nor the exact location of a potential leak can be predicted a priori, no attempt is made to use the predicted flight leakage comparison as a rationale to not perform ground leak tests. Instead, conservative ambient leakage criteria developed during MPS/SSME component development, qualification, and certification test programs and refined during ground processing operations between flights (as with the HST),

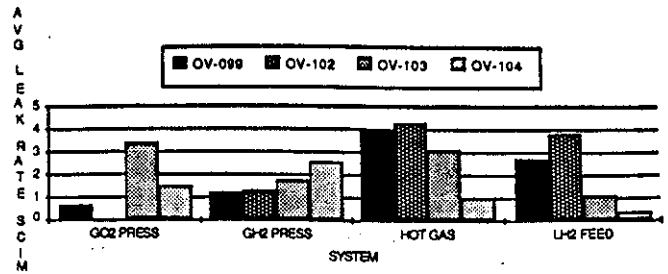

Figure 10. AVERAGE HELIUM SIGNATURE TEST DATA FOR ALL ORBITER VEHICLES.

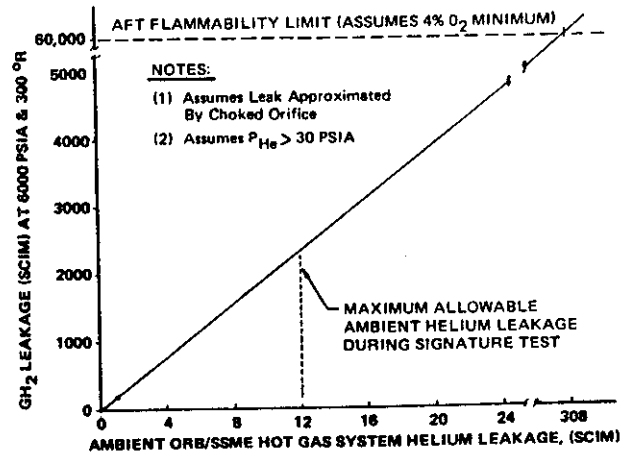

Figure 11. EQUIVALENT LEAKAGE RELATIONSHIP FOR HOT GAS SYSTEM, AMBIENT TO FLIGHT.

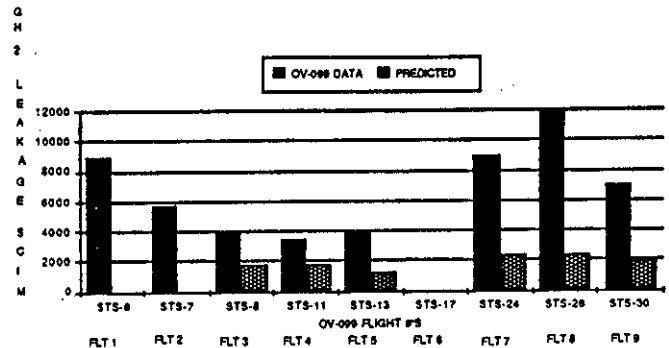

Figure 12. COMPARISON BETWEEN OV-099 ASCENT GAS SAMPLE BOTTLE DATA & PREDICTED HOT GAS SYSTEM LEAKAGE BASED ON HST RESULTS.

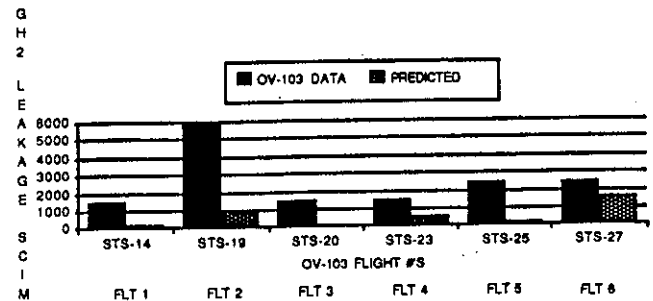

Figure 13. COMPARISON BETWEEN OV-103 ASCENT GAS SAMPLE BOTTLE DATA & PREDICTED HOT GAS SYSTEM LEAKAGE BASED ON HST RESULTS.

must be satisfied prior to committing the MPS/SSME systems for reuse. The order of magnitude agreement of Figures 12 and 13 supports this rationale.

A second important limiting factor for ground testing of liquid propellant systems is an inability to simulate the thermal conditions that the cryogenic propellants impose on connections. This problem is reflected in the comparison of LH2 system leakage shown in Tables 2 and 3. No correlation is immediately apparent from the data. Generally, the cryogenic hydrogen leak rates are two orders of magnitude larger than the HST helium values. This may be due to two factors. First, a portion of the LH2 feed system upstream of the ET/orbiter 17 inch feed and 4 inch recirculation valves is not pressurized during the HST. Thus, leakage from these valves, which can enter the aft compartment during prelift-off cryogenic propellant loading, is not reflected in the HST data. Secondly, cryogenic temperatures often increase an ambient leakage rate to a value many times higher than expected. For instance, the seal between two materials that have different thermal conductivities may be altered due to unequal thermal contractions, allowing increased leakage at cryogenic temperatures. It is very difficult to predict how any non-conformance in a mechanical or metallurgical joint will react to the change in temperature between ambient and LH2 temperatures (-420° F). Thus no attempt has been made in this paper to predict the amount of cryogenic leakage that could be expected for the HST results.

FUTURE APPLICATIONS

As a result of the successful implementation of the HST into ground turnaround operations, a similar leak test was created to check each SSME prior to installation into the orbiter. The test utilizes a flexible bag-like enclosure placed around the SSME to create a sealed control volume. Several leaks have been found and corrected prior to SSME installations.

Originally, the Shuttle Centaur upper stage vehicle was to be loaded with LH2 and LO2 during launch countdown while positioned in the Space Shuttle cargo bay. Preparations were underway to perform a helium signature test to verify Centaur vehicle leak integrity prior to launch countdown. Cancellation of the Centaur program occurred before this test could be run.

The STS External Tank consists of liquid oxygen and hydrogen tanks that are separated by an intertank structure. The HST method may be used to verify that these fuel and oxygen tanks are ready for each Shuttle mission. The Shuttle fuel cells which are located in the orbiter midbody also use LH2 and LO2 for power generation in flight. An HST is being considered to utilize the HST as a final leak test for the fuel cells.

Additional applications of the HST could include the National Aerospace Plane (NASP), the Space Station, and a second generation Shuttle or heavy lift launch vehicle. Specifically, automated or self-test capability designed into these next generation space systems would allow simplified calibration, pressurization and leak monitoring/measurement based on the HST method. For example, NASP fuel and engine compartments exposed to potential hydrogen leakage would contain built-in hydrogen/helium gas detection

TABLE 2
EXTERNAL LEAK TEST HISTORY FOR OV-099 LH2 SYSTEM

FLOW	LOCATION	DATE	HST LH2 SYSTEM LEAKAGE USING	LH2 SYSTEM CRYOGENIC LEAKAGE USING
	OF TEST	OF TEST	GHE @ 70°F (SCIM)	LH2 @ -420°F (SCIM)
STS-7	OPF	05-10-83	6.4	1000
STS-8	OPF	07-16-83	2.0	1000
STS-11	OPF	12-08-83	0.8	3520
STS-13	OPF	03-09-84	0.0	1000
STS-17	PAD	09-25-84	0.0	880
STS-24	PAD	11-28-84	0.5	900
STS-26*	PAD	06-30-85	5.5	1300
STS-26	PAD	07-23-85	2.2	2365
STS-30	PAD	10-18-85	3.2	880
STS-33	PAD	01-05-86	0.0	900

.....
*LAUNCH ABORT

TABLE 3
EXTERNAL LEAK TEST HISTORY FOR OV-103 LH2 SYSTEM

FLOW	LOCATION	DATE	HST LH2 SYSTEM LEAKAGE USING	LH2 SYSTEM CRYOGENIC LEAKAGE USING
	OF TEST	OF TEST	GHE @ 70°F (SCIM)	LH2 @ -420°F (SCIM)
FRF			0.0	1000
STS-14	OPF	06-15-84	0.0	1000
STS-14*	PAD	07-09-84	0.8	1000
STS-14	PAD	08-12-84	1.8	1000
STS-19	PAD	11-01-84	0.0	880
STS-20	PAD	01-15-85	12.6**	1000
STS-23	OPF	02-26-85	0.0	1180
STS-25	OPF	05-16-85	3.6	2365
STS-27	PAD	08-03-85	1.4	880

.....
*LAUNCH ABORT
**12.6 SCIM LEAK WAS ORIGINALLY DETECTED AT FUEL JOINT AND CORRECTED.

instrumentation, helium distribution lines for injection of calibrated leakage, and vent doors which would allow sealing the compartment down to a single opening. A ground helium pressurization source would be connected to the vehicle, and an HST could be controlled automatically by an on-board flight computer. Any excessive leakage would be identified for further investigation by ground crews. The HST could thus provide a relatively quick system level revalidation that would support the very short turnaround (i.e. a few days) proposed for NASP. Similarly, designed in HST capability could save many hours of astronaut troubleshooting during on-orbit testing of fluid systems integrity on the Space Station.

These examples demonstrate the versatility and significance of the test application within the rocket industry. Most cryogenic or high pressure systems should be utilizing this technique when external leakage of hazardous fluids into closed volumes must be minimized.

CONCLUSIONS AND RECOMMENDATIONS

The helium signature test is a major test in the ground processing flow for Space Shuttle orbiters. The test is effective in detecting leakage from propellant systems with an accuracy of ± 3 scim. The correlation between HST data and other leak detection data is good as demonstrated by the experience on OV-103 FLT #3 and OV-099 FLT #2. Comparisons between HST hot gas system leakage and the ascent gas sample bottle data indicate that there is a reasonable correlation between these data when all factors and system inaccuracies are considered. These results demonstrate that overall STS flight safety is enhanced by use of the HST technique.

There is no apparent correlation between the HST LH2 feed system data and the prelift-off cryogenic system data. This is most likely due to thermal affects and LH2 feed system pressurization constraints at ambient conditions. It is important to expand the HST to include all of the LH2 feed system so that a better definition of ambient system leakage can be obtained.

Future applications of this test technique to other parts of the STS as well as other current and future systems are recommended.

ACKNOWLEDGEMENT

The authors are very grateful for the cooperation and dedication of all the members of the KSC launch processing team who have worked diligently to make this test technique and the Shuttle Program a success. Of particular note is the contribution of Mr. John Sterritt of Lockheed Space Operations Co. to test setup development. They also wish to thank Mr. Joseph Clegg and Mr. Tibor Lak of Rockwell International for their analytical contributions. Special thanks to Ms. Pat Green of Rockwell and Ms. Shirley Pencka of EG&G for manuscript and graphics preparation, respectively.

REFERENCES

1. Benz, F. J. and Voucher, P. L., "Flammability Characteristics Of H₂/O₂/N₂ Mixed At Reduced Pressure", NASA-JSC White Sands Test Facility, 1979.
2. Bilardo, V. J., "Reducing The Turnaround Time For The Shuttle Orbiter Main Propulsion System At Kennedy Space Center," AIAA-83-2623-CP, AIAA Shuttle Environment And Operations Meeting, Washington, D.C., October 1983.
3. NASA Lyndon B. Johnson Space Center, Shuttle Flight Operations Manual, Main Propulsions Systems, Volume 8A, JSC-12770, Houston, TX, August 1981.
4. Rockwell International - Rocketdyne Div., SSME Training Data, Engine Orientation Course ME-110 RIR, Canoga Park, CA, October 1980.
5. Rockwell International Shuttle Launch Operations Division, "Report of the OV-099 FRF6-2 Special Instrumentation Installation And Data Analysis", Kennedy Space Center, FL, February 4, 1983.
6. Bilardo, V. J. and Smith, R. K. "STS-11 OV-099 Helium Signature Test", Avoid Verbal Orders, Kennedy Space Center, FL, January 30, 1984.
7. Holman, J. P., Experimental Methods For Engineers, 3rd Edition, McGraw Hill, Inc., New York, NY, © 1978.
8. Burg, R. A., "Ascent Hazardous Gas Analysis Milestone For Operations", Internal Letter No. 289-001-81-027, Rockwell International - Space Transportation and Systems Group, Downey, CA, October 12, 1982.
9. McMaster, R. C., Ed., Nondestructive Testing Handbook - Vol. 1 Leak Testing, ASNT, 2nd Edition, Columbus, OH, © 1982.
10. Rockwell International Corporation Press Information for Space Shuttle Transportation System Copyright 1984.
11. Mortenson, Garry D. and Olney, J. Neil, "Ambient Leak Test of Space Shuttle orbiter Liquid Hydrogen and Oxygen Disconnects" STS 82-0102, 28th International Instrumentation Symposium Aerospace Industries & Test Measurements Division Instrument Society of America, May 3-6, 1982.